

To attach disk (I) to disk (II), pass the cord through the pearls following the path of the arrows (.....) and then make a knot.
 Attach disk (II) to disk (III) using the same method (path_.....).

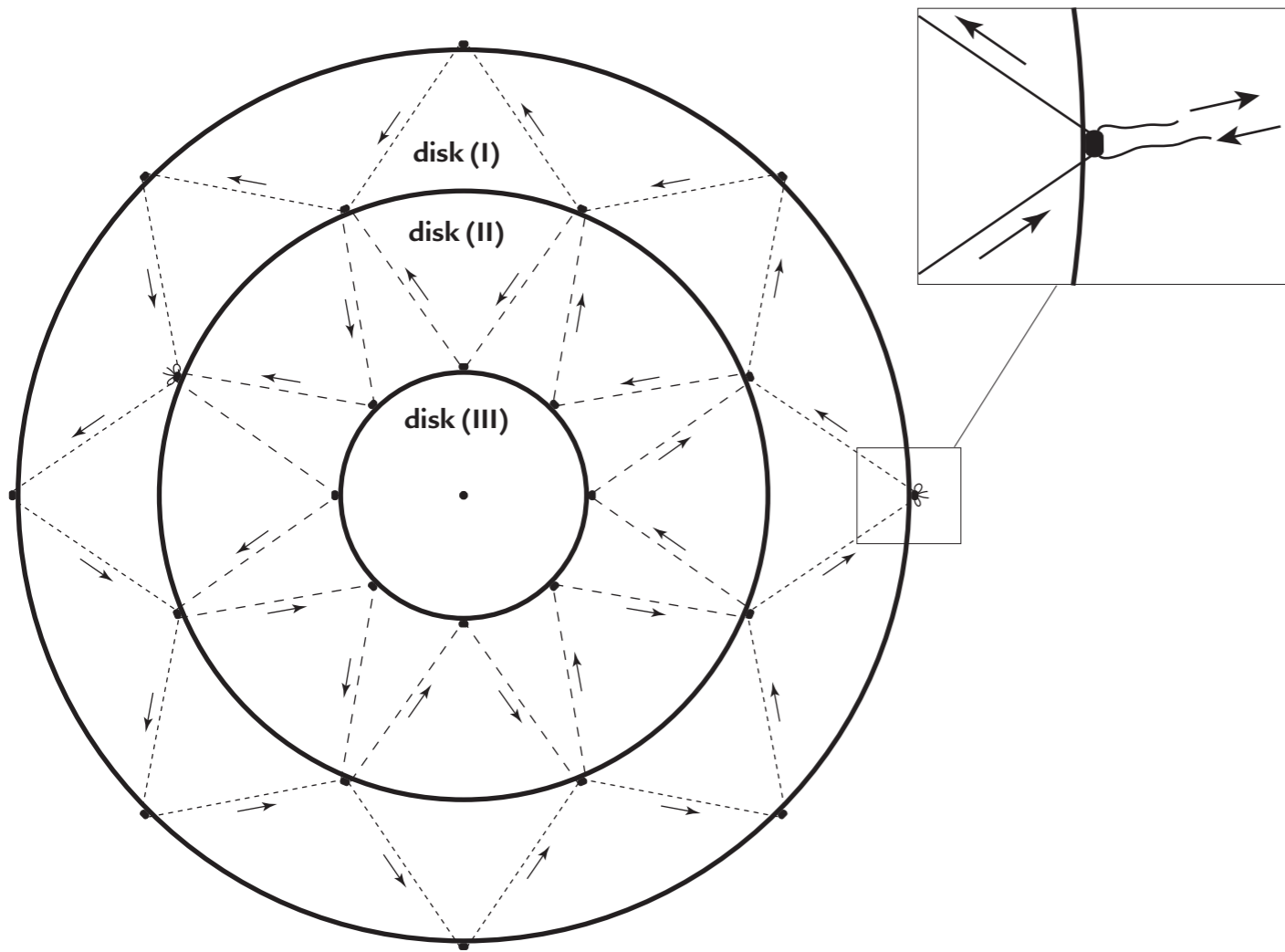

VENETIA STUDIO S.r.l.
 S.Marco 2425 30124 VENEZIA
 tel.: +39 (0)41 5236953
 fax: +39 (0)41 5227353
 www.venetiastudium.com
 info@venetiastudium.com

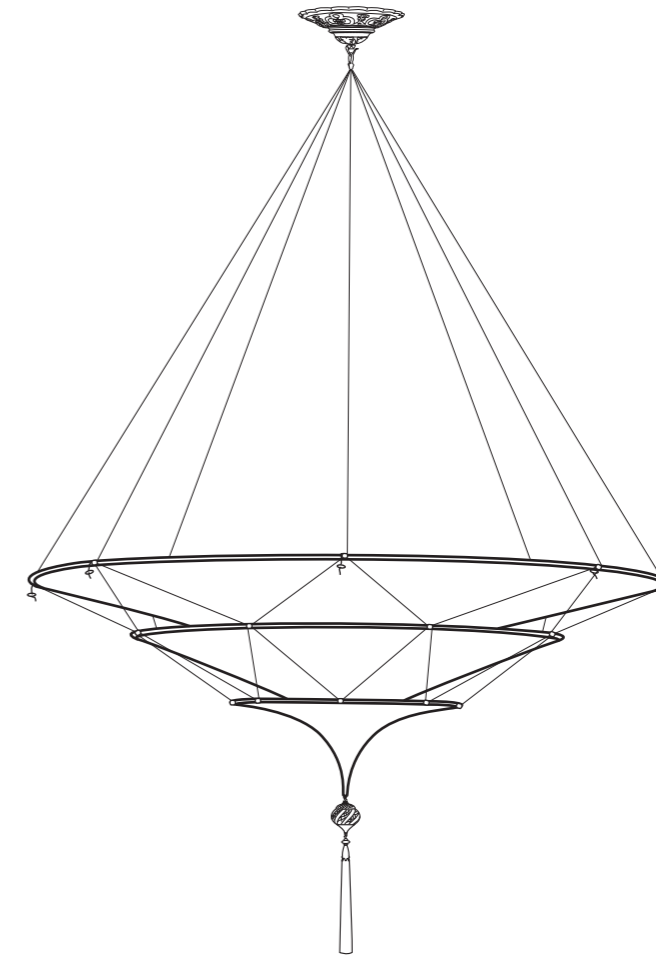

**SCHEHERAZADE
 MOUNTING INSTRUCTIONS
 for the suspended version**

GENERAL:

- 1) Read all instructions and review diagrams beginning with the installation of the fixture.
- 2) All electrical connections must be in accordance with local codes, ordinances or the National electrical code. If you are unfamiliar with methods of electrical wiring, secure the services of a qualified licensed electrician.
- 3) These fixtures are intended to be mounted to a metal octagon electrical box. The electrical box must be attached to and directly supported by the building structure.

BEFORE BEGINNING INSTALLATION:

- a) Turn off the electricity to the outlet box at the circuit breaker or fuse box.
- b) If you are replacing an existing fixture, remove the old fixture and expose the supply wiring from the outlet box.
- c) Remove the old cross bar from the outlet box and save the two outlet box screws.

CAUTION:

Due to the fixture size, it may be necessary for more than one person to assist in the installation of this lamp

Structure:	brass
Fabric:	pure silk
Murano glass beads	
Weight:	9 lbs. 11 oz.
Recommended wattage:	60 - 100 watts

Vacuuming is recommended every few months, as keeping the lamps dust free will prolong their life.

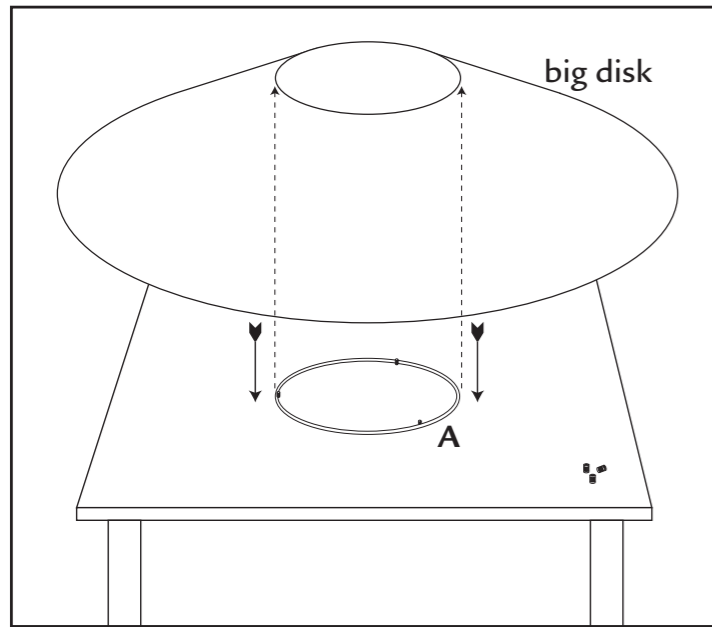

1) Lay the big disk over element **A**.

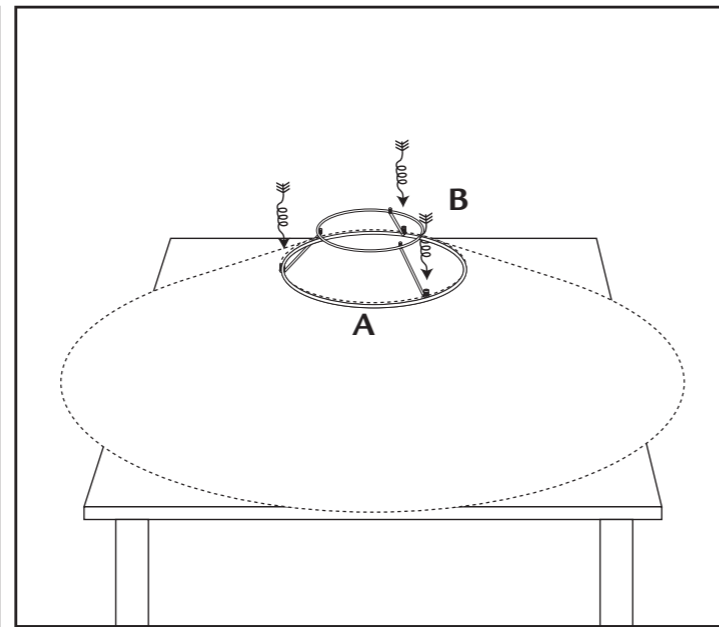

2) Insert element **B** and tighten the three screws on element **A**.

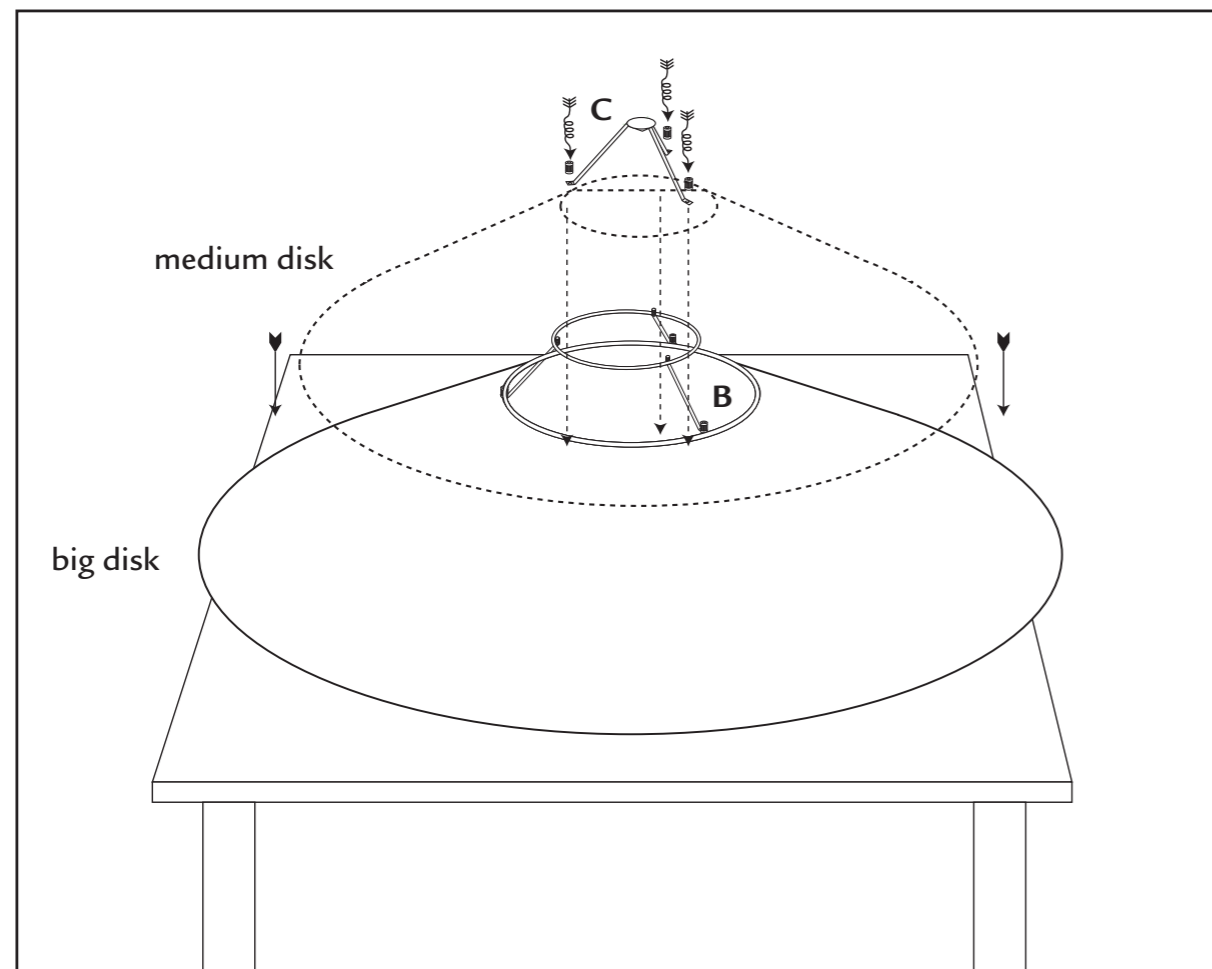

3) Insert the medium disk into element **B**.

4) Insert element **C** and tighten the three screws that will hold it in place.

5) Now you can hang the big disk to the ceiling attachment.

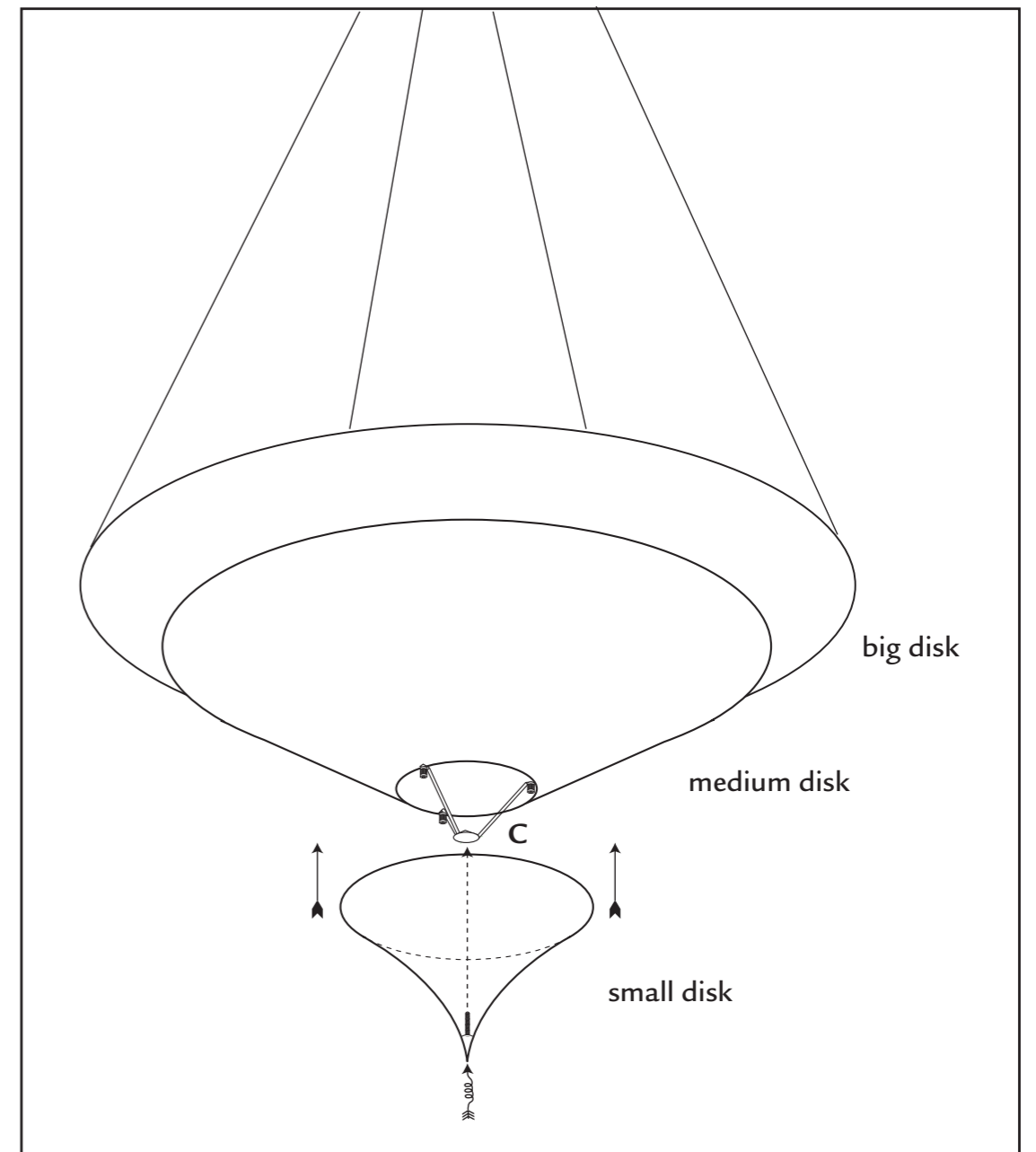

6) Screw the small disk onto element **C**.

7) Connect the three disks using the set of cords provided (see next page).

8) Install bulb. Do not exceed the maximum wattage for this fixture. Refer to the wattage warning label attached to the fixture for maximum allowable wattage.

9) Restore the electricity and test.