



LifeTime™

LED Back-lit Panel



Beyond LED LIFETIME Backlit panels are ultra thin, super bright which offers uniform illumination and excellent energy savings. Our LIFETIME panels deliver soft, ambient lighting in a popular backlit design. LIFETIME is available in 5 Adjustable wattages and 5 Adjustable CCT . The slim profile and energy-saving LED technology makes the LIFETIME the ideal choice for renovation or new construction. It is also suitable for use in commercial buildings, libraries, hospitals, office, hotels, corridors etc.

Product Features

- Available in 2x2, 1x4 & 2x4
- Up to 125 Lumens per watt
- 5 Adjustable Wattages
- 5 Adjustable CCT 3K/3500K/4K/5K/6500K
- Dimmable 0-10V
- Flicker free driver available
- Uniform light effect with Optic PMMA Lens
- Recessed / Suspended / Surface mount
- Input Voltage 120-277Vac
- UL & DLC Listed
- 5 Year warranty

LifeTime™

LED Back-lit Panel



SKU #	Model #	Wattage Adj.	Lumens	CCT Adj.	Size	Input Voltage	Certifications
156793	BLT-PL2X2-40W-A5C5-P	20W/25W/30W 35W/40W	5000Lm	3K/3500K/4K 5K/6500K	2'X2'	120-277Vac	UL & DLC
156722	PL1X4-40W-A5C5-P	20W/25W/30W 35W/40W	5000Lm	3K/3500K/4K 5K/6500K	1'X4'	120-277Vac	UL & DLC
156702	BLT-PL2X4-72W-A5C5-P	30W/40W/50W 60W/72W	9000Lm	3K/3500K/4K 5K/6500K	2'X4'	120-277Vac	UL & DLC

SKU: 156793

Specifications

Parameter	Description	Value
General Performance	Model #	BLT-PL2X2-40W-A5C5-P
	Wattage Adjustable	20W / 25W / 30W / 35W / 40W
	Lumens	Up to 5000LM
	Lumen Efficacy	Up to 125LM/W
	Color Temperature	3000K / 3500K / 4000K / 5000K / 6500K
	CRI (Ra)	>80
	Beam Angle	120° Degree
	Diffuser Type	PMMA Lens
Electrical	Input Voltage	120-277Vac
	Frequency	50/60Hz
	THD	<20%
	Dimming	0-10V Dimmable
	Power Factor	≥0.90
	Flicker Free	Yes
Physical	Driver Model	HXS
	Operating Temperature	-20°C To 45°C
	Operating Humidity	10% - 90% RH
	Storage Humidity	10% - 90% RH
	LED Brand	Lumileds
	LED Type	SMD 2835
	LED QTY	141 pcs
Qualification	Housing Color	White
	IP Rating	IP40
	Warranty	5 Year warranty



LifeTime™

LED Back-lit Panel

SKU: 156722

Specifications

Parameter	Description	Value
General Performance	Model #	PL1X4-40W-A5C5-P
	Wattage Adjustable	20W / 25W / 30W / 35W / 40W
	Lumens	Up to 5000LM
	Lumen Efficacy	Up to 125LM/W
	Color Temperature	3000K / 3500K / 4000K / 5000K / 6500K
	CRI (Ra)	>80
	Beam Angle	120° Degree
	Diffuser Type	PMMA Lens
Electrical	Input Voltage	120-277Vac
	Frequency	50/60Hz
	THD	<20%
	Dimming	0-10V Dimmable
	Power Factor	≥0.90
	Flicker Free	Yes
Physical	Driver Model	HXS
	Operating Temperature	-20°C To 45°C
	Operating Humidity	10% - 90% RH
	Storage Humidity	10% - 90% RH
	LED Brand	Lumileds
	LED Type	SMD 2835
LED QTY	141 pcs	
Qualification	Housing Color	White
	IP Rating	IP40
	Warranty	5 Year warranty

LifeTime™

LED Back-lit Panel



SKU: 156702

Specifications

Parameter	Description	Value
General Performance	Model #	BLT-PL2X4-72W-A5C5-P
	Wattage Adjustable	30W / 40W / 50W / 60W / 72W
	Lumens	Up to 9000LM
	Lumen Efficacy	Up to 125LM/W
	Color Temperature	3000K / 3500K / 4000K / 5000K / 6500K
	CRI (Ra)	>80
	Beam Angle	120° Degree
	Diffuser Type	PMMA Lens
Electrical	Input Voltage	120-277Vac
	Frequency	50/60Hz
	THD	<20%
	Dimming	0-10V Dimmable
	Power Factor	≥0.90
	Flicker Free	Yes
Physical	Driver Model	HXS
	Operating Temperature	-20°C To 45°C
	Operating Humidity	10% - 90% RH
	Storage Humidity	10% - 90% RH
	LED Brand	Lumileds
	LED Type	SMD 2835
	LED QTY	150 pcs
Qualification	Housing Color	White
	IP Rating	IP40
	Warranty	5 Year warranty

LED BACK-LIT PANEL



LifeTime™

LED Back-lit Panel

Accessories

2'x2'



2'x2'



Surface Mounting Kit
SKU: 156833

1'x4'



1'x4'



Surface Mounting Kit
SKU: 156810

2'x4'



2'x4'



Surface Mounting Kit
SKU: 156723



Suspension Kit



Optional
Emergency Driver
SKU: 156740



PIR Motion Sensor
SKU: 156704

LED BACK-LIT PANEL

LifeTime™

LED Back-lit Panel



Correlated Color Temperature (CCT)

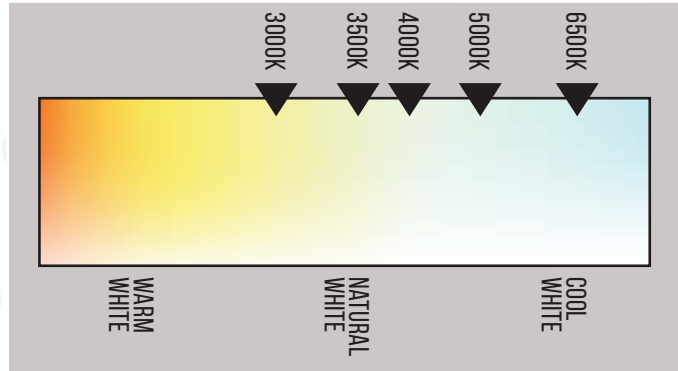

Dimensions

2 x 2

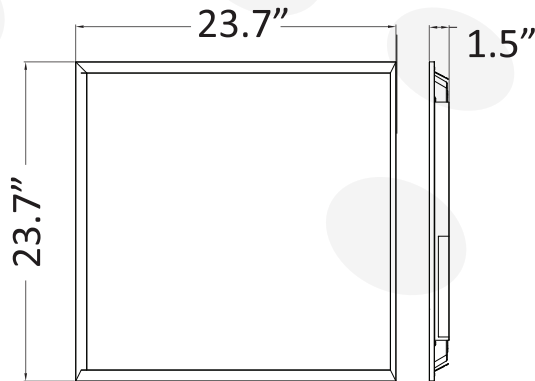

1 x 4

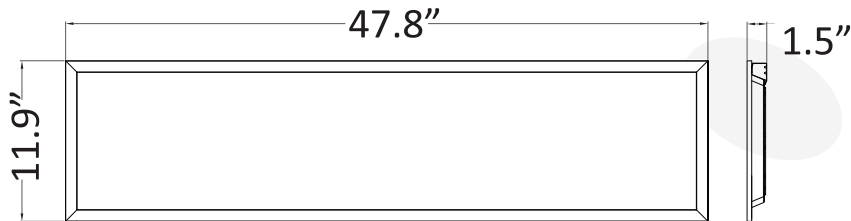

2 x 4

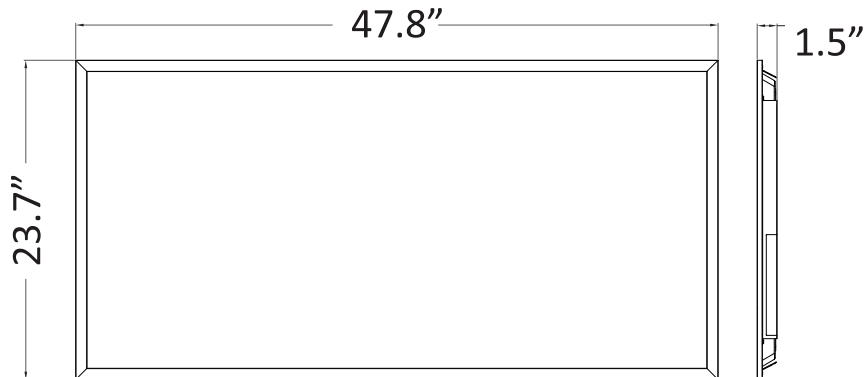



LifeTime™

LED Back-lit Panel

SKU: 156793

Photometric Data

LUMINOUS INTENSITY DISTRIBUTION DIAGRAM

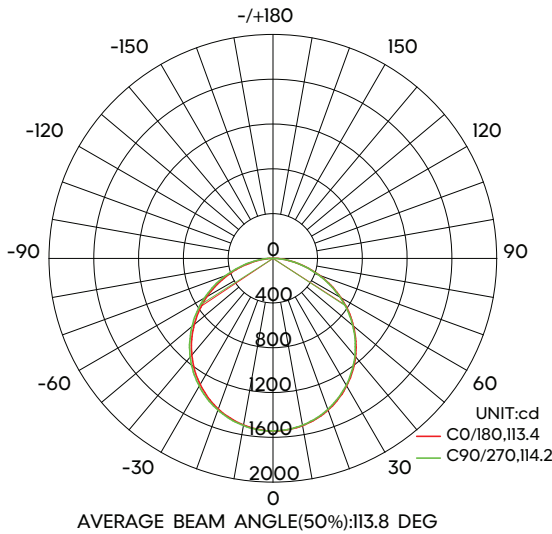

C0 PLANE ISOLUX DIAGRAM (UNIT:lx)

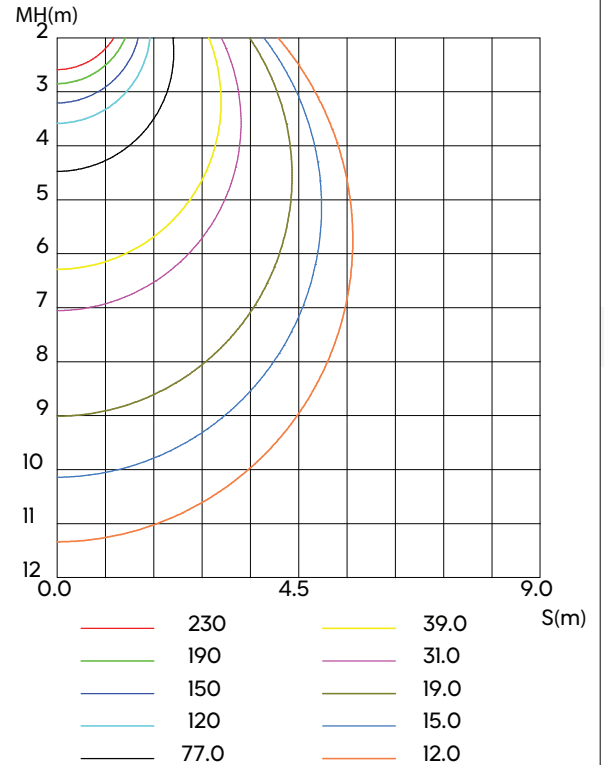

C Range: 0 - 360DEG
 C Interval: 45.0DEG
 Test Speed: HIGH
 Temperature: 25.3°C
 Operators: LIXIAOFEI
 Test Date: 2023-10-30

Y Range: 0 - 90DEG
 Y Interval: 1.0DEG
 Test System: EVERFINE GO-2000H_V1 SYSTEM V2.00.456
 Humidity: 65.0%
 Test Distance: 9.750m [K=1.0000]
 Remarks:

LED BACK-LIT PANEL

LifeTime™

LED Back-lit Panel



SKU: 156793

Photometric Data

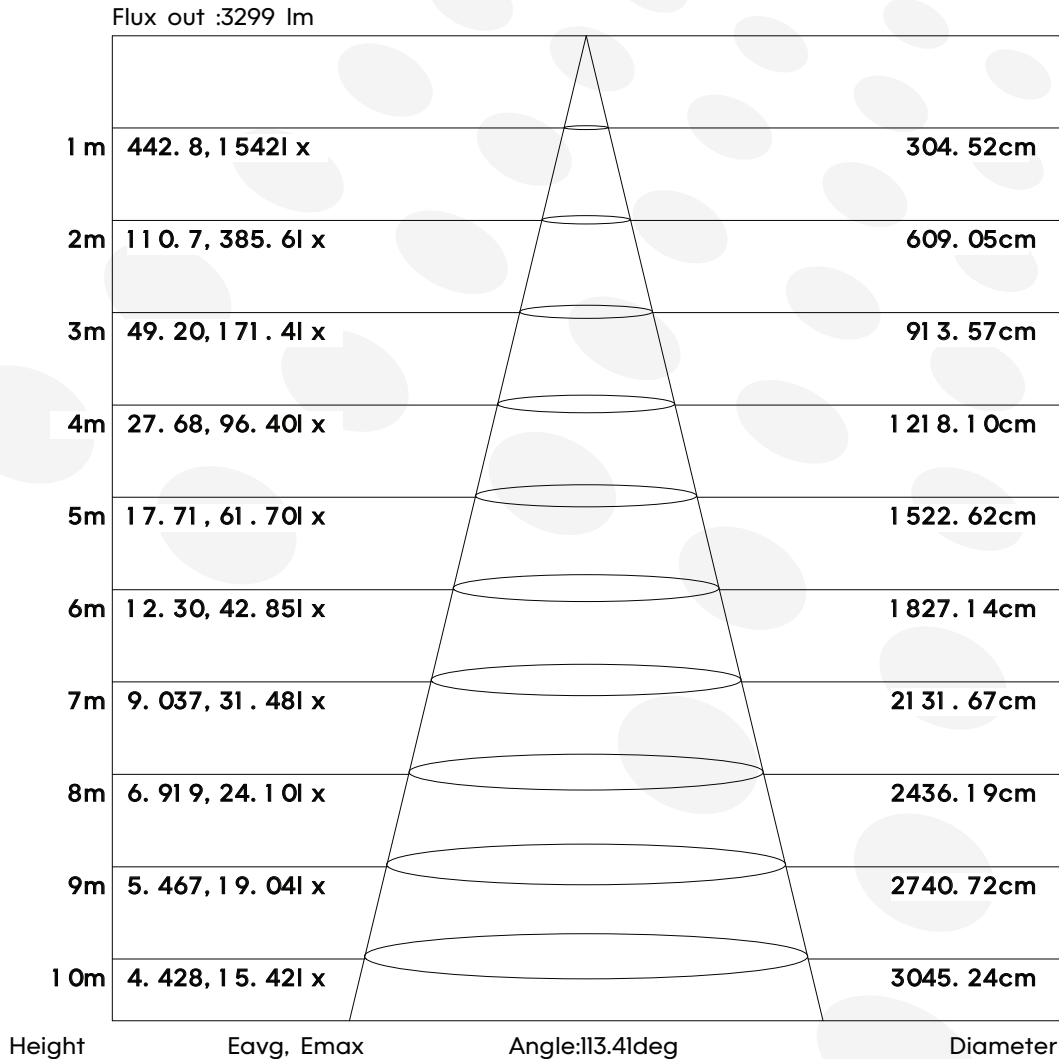

Note: The Curves indicate the illuminated area and the average illumination when the luminaire is at different distance.

C Range: 0 - 360DEG
 C Interval: 45.0DEG
 Test Speed: HIGH
 Temperature: 25.3°C
 Operators: LIXIAOFEI
 Test Date: 2023-10-30

γ Range: 0 - 90DEG
 γ Interval: 1.0DEG
 Test System: EVERFINE GO-2000H_V1 SYSTEM V2.00.456
 Humidity: 65.0%
 Test Distance: 9.750m [K=1.0000]
 Remarks:

LED BACK-LIT PANEL



LifeTime™

LED Back-lit Panel

SKU: 156722

Photometric Data

LED BACK-LIT PANEL

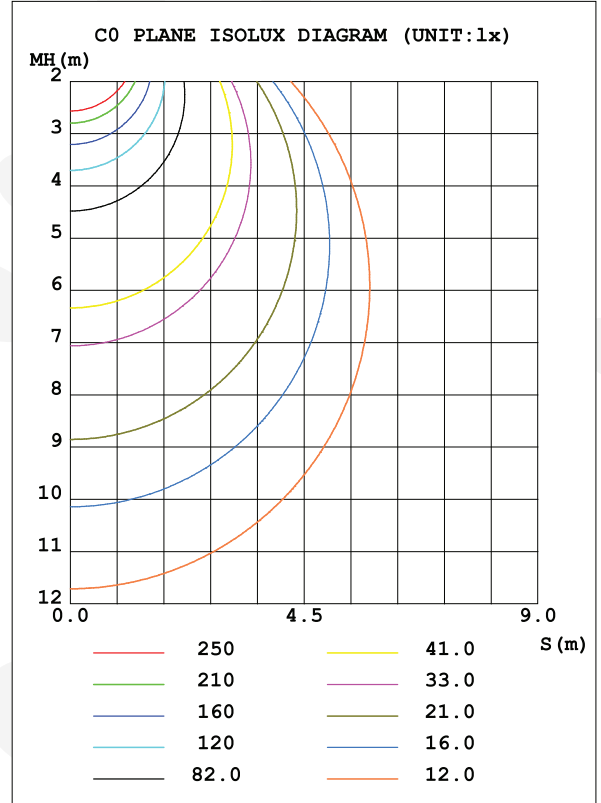
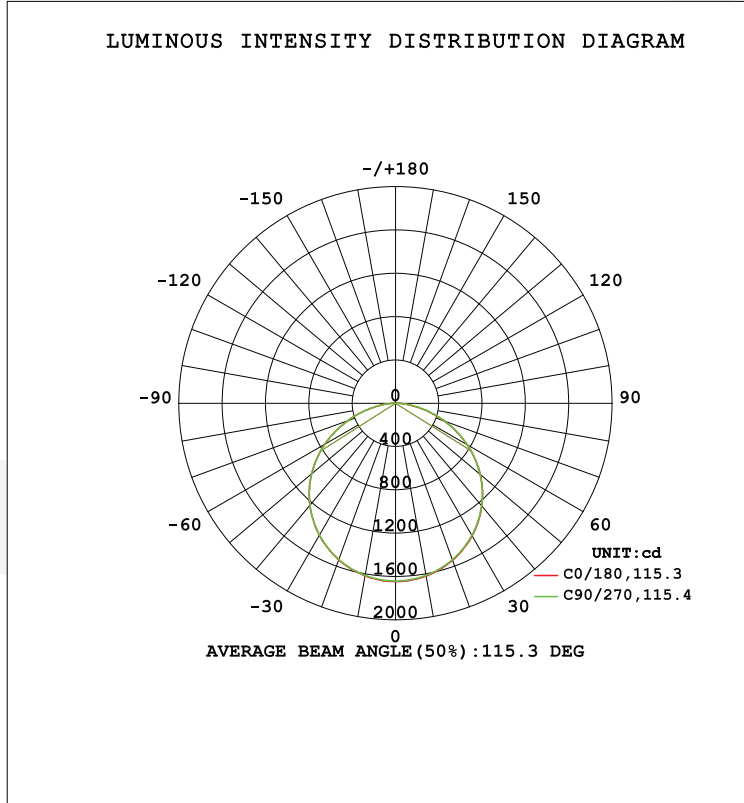

C Range: 0 - 360DEG
 C Interval: 22.5DEG
 Test Speed: HIGH
 Temperature: 25.3°C
 Operators: DAMIN
 Test Date: 2022-11-17

□ Range: 0 - 90DEG
 □ Interval: 1.0DEG
 Test System: EVERFINE GO-2000H_V1 SYSTEM V2.00.461
 Humidity: 65.0%
 Test Distance: 9.680m [K=1.0000]
 Remarks:

LifeTime™

LED Back-lit Panel



SKU: 156722

Photometric Data

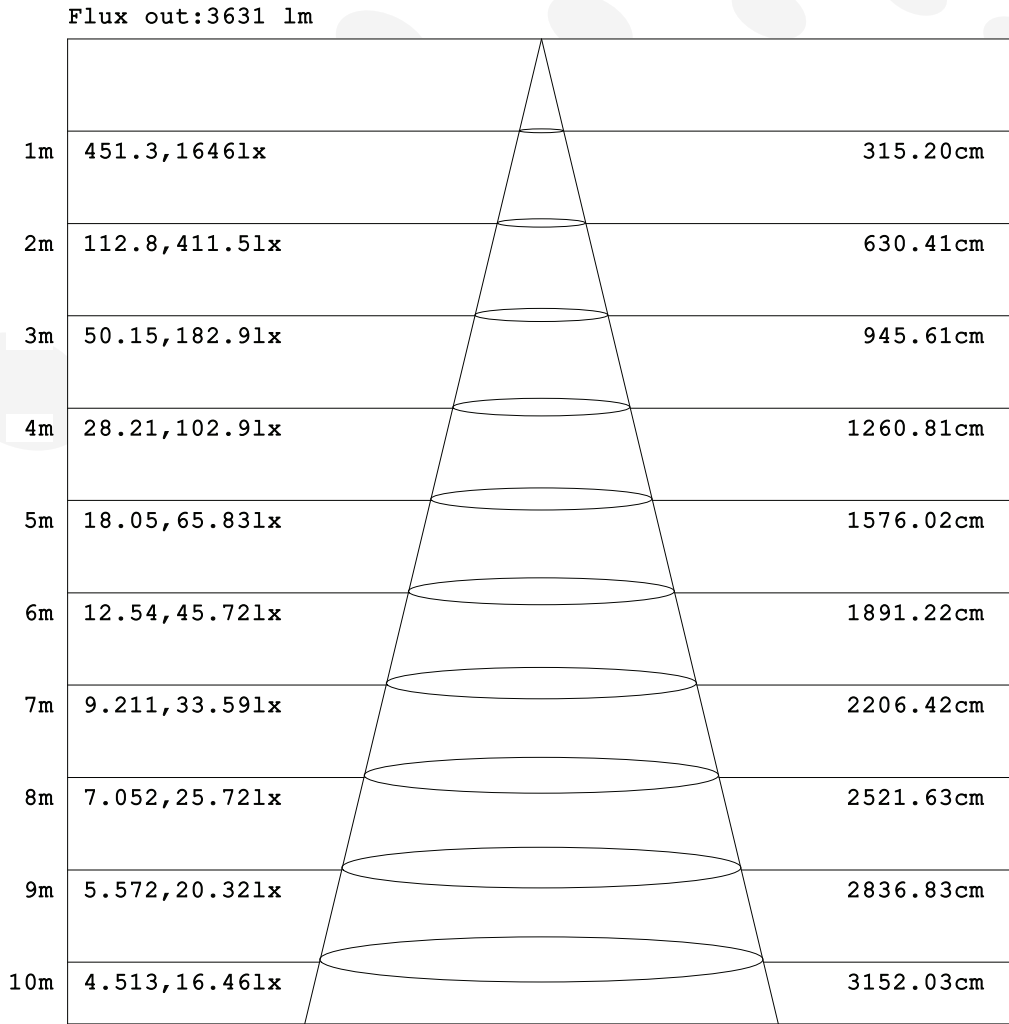

Height Eavg, Emax Angle: 115.21deg Diameter

Note: The Curves indicate the illuminated area and the average illumination when the luminaire is at different distance.

LED BACK-LIT PANEL

C Range: 0 - 360DEG
 C Interval: 22.5DEG
 Test Speed: HIGH
 Temperature: 25.3°C
 Operators: DAMIN
 Test Date: 2022-11-17

Range: 0 - 90DEG
 Interval: 1.0DEG
 Test System: EVERFINE GO-2000H_V1 SYSTEM V2.00.461
 Humidity: 65.0%
 Test Distance: 9.680m [K=1.0000]
 Remarks:



LifeTime™

LED Back-lit Panel

SKU: 156702

Photometric Data

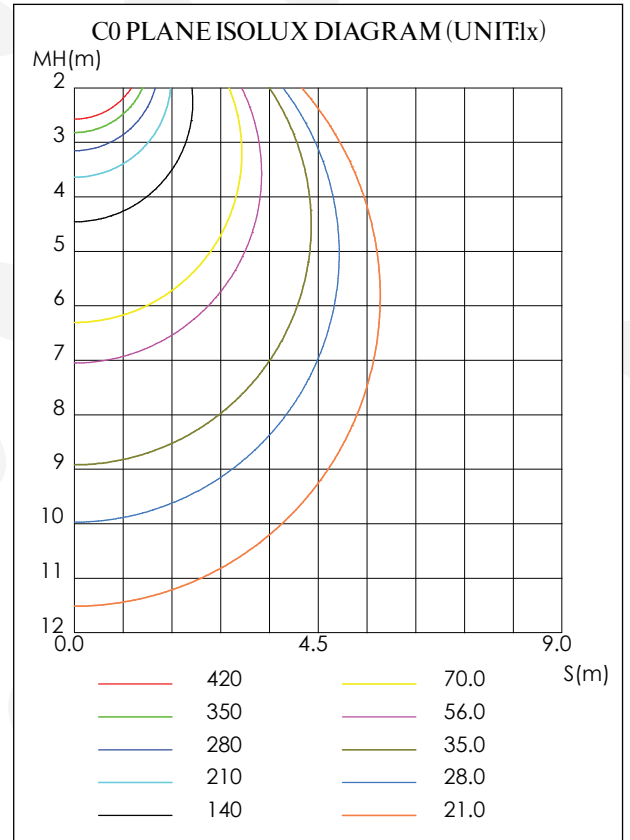
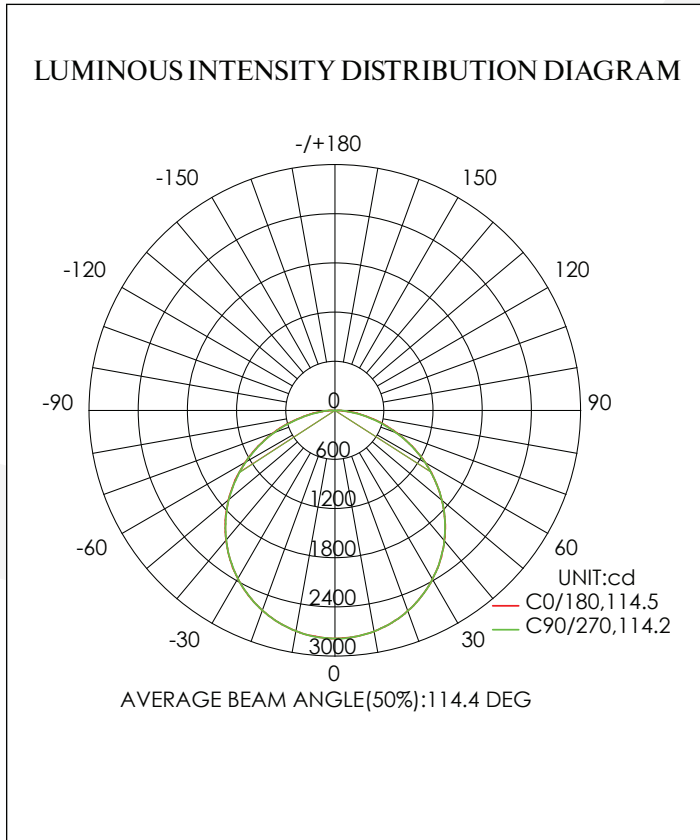

C Range: 0 - 360DEG
 C Interval: 22.5DEG
 Test Speed: HIGH
 Temperature: 25.3°C
 Operators: DAMIN
 Test Date: 2023-04-27

γ Range: 0 - 90DEG
 γ Interval: 1.0DEG
 Test System: EVERFINE GO-2000H_V1 SYSTEM V2.00.456
 Humidity: 65.0%
 Test Distance: 9.850m [K=1.0000]
 Remarks:

LifeTime™

LED Back-lit Panel



SKU: 156702

Photometric Data

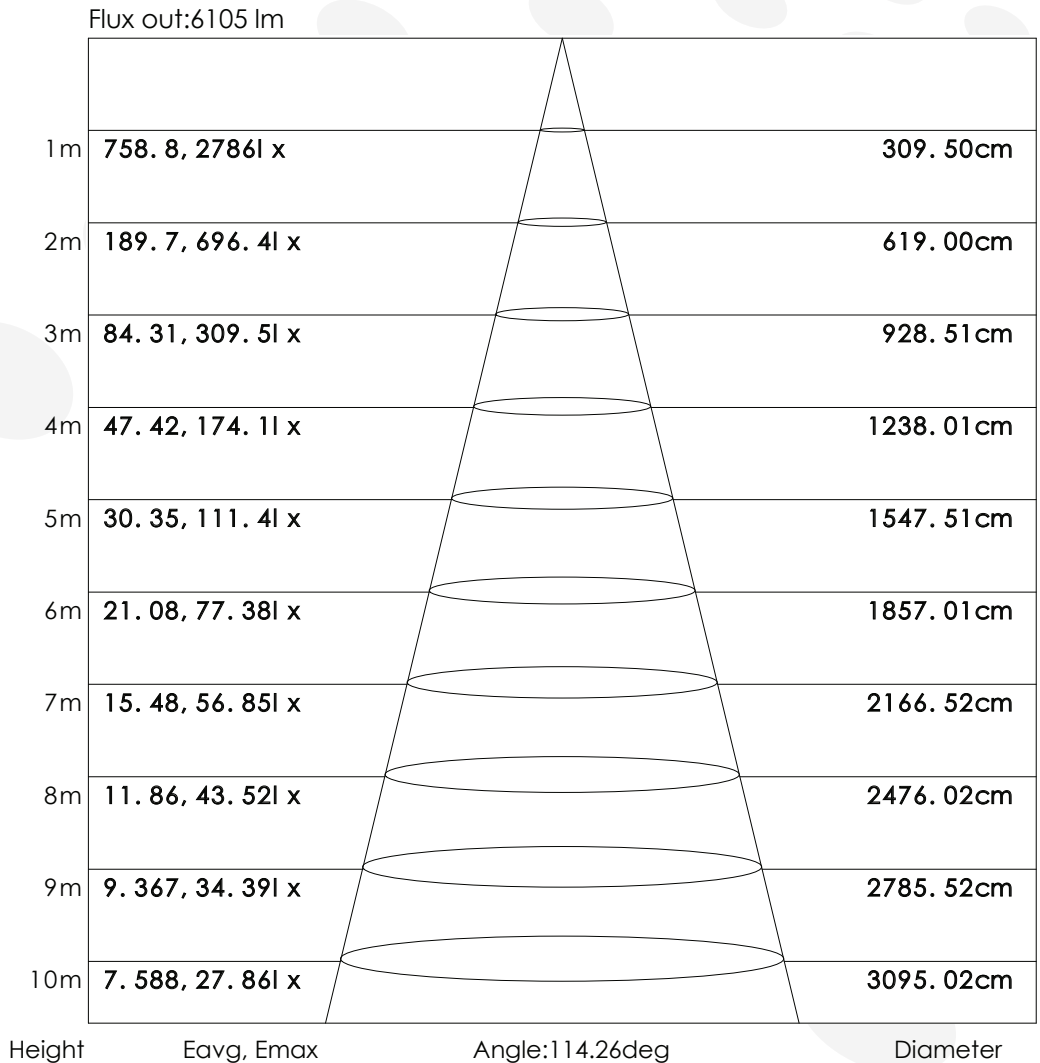

Note: The Curves indicate the illuminated area and the average illumination when the luminaire is at different distance.

C Range: 0 - 360DEG
 C Interval: 22.5DEG
 Test Speed: HIGH
 Temperature: 25.3°C
 Operators: DAMIN
 Test Date: 2023-04-27

γ Range: 0 - 90DEG
 γ Interval: 1.0DEG
 Test System: EVERFINE GO-2000H_V1 SYSTEM V2.00.456
 Humidity: 65.0%
 Test Distance: 9.850m [K=1.0000]
 Remarks:

LED BACK-LIT PANEL



LifeTime™

LED Back-lit Panel

Installation

■ Safety Instruction:

Basic safety precautions should always be followed when installing, including the following:

1. Read instructions carefully before installing.
2. This LED Panel requires professional installation and maintenance.
3. The power supply of the LED Panel should be powered by a dedicated external LED driver.
4. Disconnect the power supply before installing or maintenance.
5. Make sure the wires have been properly connected before powering on the device.
6. Ensure the product has enough space for heat dissipation.
7. Ensure the luminaries are never covered by any heat insulation mat or slim layer material at anytime.
8. This product is to be installed by a qualified electrician only.
9. Suitable for damp location use.

■ Installation Procedure

⚡ WARNING:

1. Switch off before installation.
2. Switch on only after complete installation and examination of the circuit.
3. Product modification and improper installation are not valid for warranty!

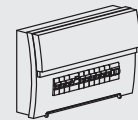

**Turn Off
Power Supply**

⚠ CAUTION:

Make sure that the mounting surface or structural member used for installation can support the weight of LED Panel.

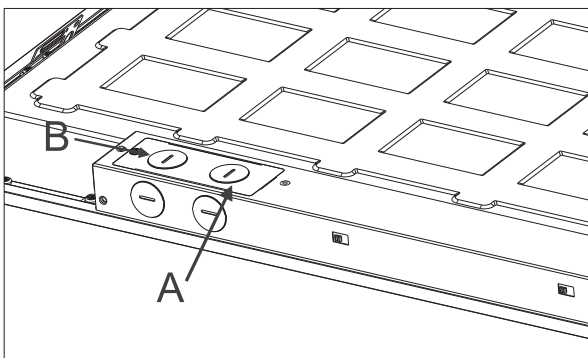

- (1) Remove the knock-down hole on box by screwdriver (Part A), Remove screw and take out the driver cover (Part B)

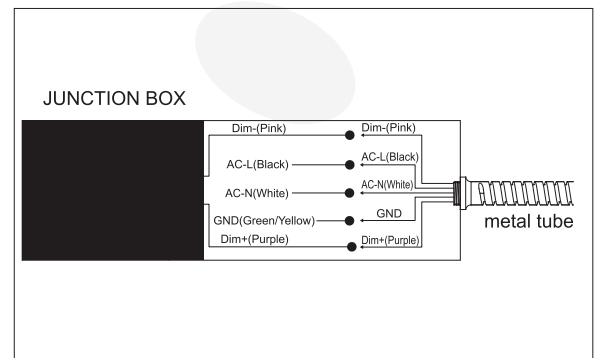

- (2) Connect the wire as the picture showing.

LifeTime™

LED Back-lit Panel



Installation

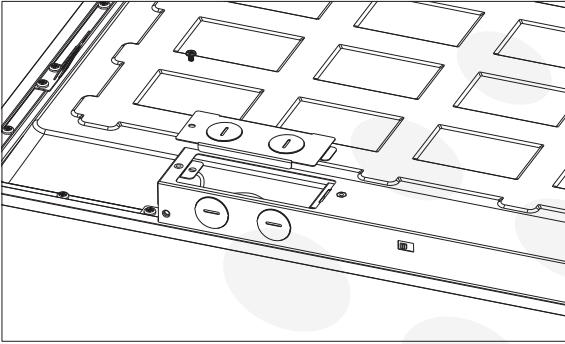

For the product with Slide Switch of CCT or power selection, please select the CCT or power needed before installation.

Slide switch for power selection



Slide switch for color selection



(3) Cover the driver box and tighten it with a screwdriver, finish connection.



Lamp inspection before installation: Take out the lamp from the box and put it in a flat table, if the lamp upwarps, please adjust the lamp with below steps before installation:

1. Press the opposite angles at the same time;
2. Press another two opposite angles at the same time, make sure the four angles are flat, then start the installation.

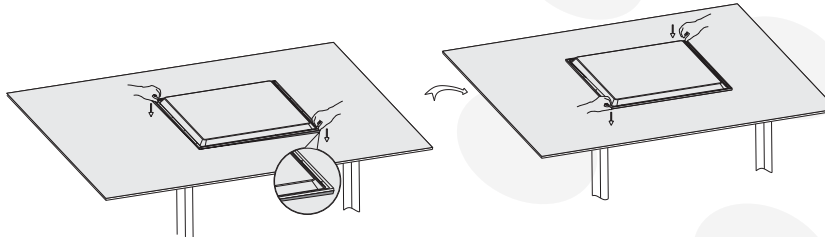

Recessed

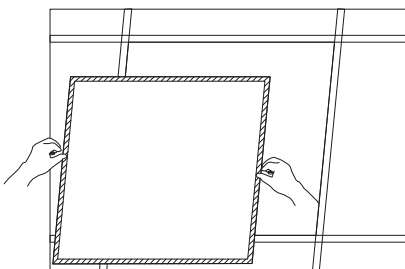

① Remove the ceiling plaster slab.

② Feed the main AC wire in driver terminal block respectively, connect the panel light and driver.

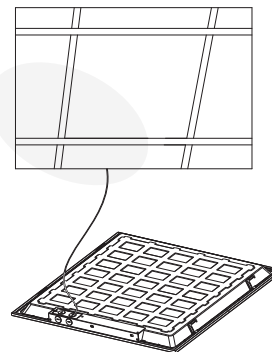

③ Fix the panel light into plaster ceiling.

④ Make sure the led panel light is firmly fixed, turn on the power.

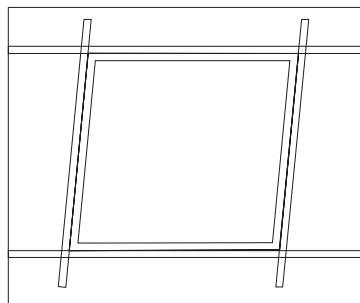



LifeTime™

LED Back-lit Panel

Installation

Suspended

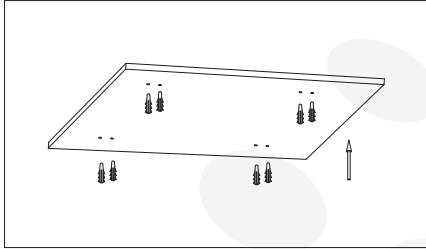

← ① Fix the anchor into target place on the ceiling.

② Fix the installation mount on the ceiling with plastic anchor.

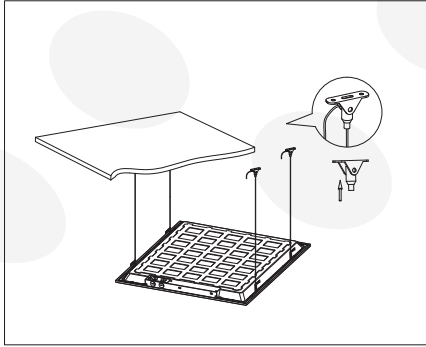
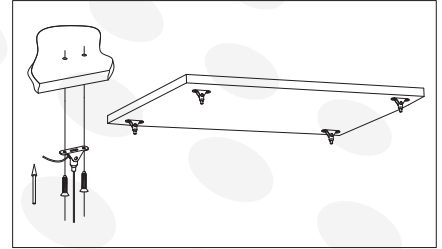

← ③ Hang the panel to ceiling with suspended installation kits, adjust the length of steel wires.

④ Feed the main AC wire in driver terminal block respectively, turn on the power.

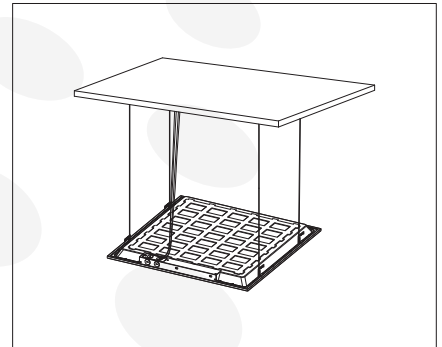

Warning:

Input wire diameter $\geq 0.75\text{mm}^2$;

Product modification and improper installation are not valid for warranty!

LifeTime™

LED Back-lit Panel



Packaging

SKU #	Size	Dimension	Qty	Net Weight	Gross Weight
156793	2 x 2	25.78 x 12.79 x 25.70	6 Pcs/Ctn	23.3 LBS	30.6 LBS
156722	1 x 4	49.80x12.80 x13.90"	6 Pcs/Ctn	29.10 LBS	36.15 LBS
156702	2 x 4	49.80 x 8.66 x 25.70"	4 Pcs/Ctn	35.27 LBS	43.21 LBS

Application



LED BACK-LIT PANEL



LifeTime™

LED Back-lit Panel

Application



LED BACK-LIT PANEL

LifeTime™

LED Back-lit Panel



Application



LED BACK-LIT PANEL

Warranty

5 Year Warranty