

# LED Area Light



Nothing But LEDs Area light is the most economical and newest 2021 model. Our Area light offers high lumens per watt for maximum power savings and rebates from power companies. Our Area light is a perfect solution for lighting parking areas, loading docks and other general lighting applications.

- High Efficiency Seoul Chip
- Ultra thin sleek design
- Up to 139 lumens per watt
- Optional 3 pin Screw-in photocell
- Built-in 10KV Surge protector
- Several bracket options
- Heat resistant polycarbonate optical lens
- Die Cast Aluminum housing
- Available in White, Grey, Bronze and Black Housing
- Universal 100-277Vac / 480Vac optional
- DLC Premium Approved

SKU #	Model #	Housing	Watts	Lumens	CCT	IP	Input Voltage	Certifications
151341	BLT-ALHL150W-50K-III-[D;N]R	Black	150W	21578.8Lm	5000K	IP65	100-277Vac	UL & DLC
151342	BLT-ALHL320W-50K-III-[D;N]R	Black	320W	42941.5Lm	5000K	IP65	100-277Vac	UL & DLC
151340	BLT-ALHL150W-50K-III-[D;N]R	Bronze	150W	21578.8Lm	5000K	IP65	100-277Vac	UL & DLC
151343	BLT-ALHL320W-50K-III-[D;N]R	Bronze	320W	42941.5Lm	5000K	IP65	100-277Vac	UL & DLC
151339	BLT-ALHL150W-50K-III-[D;N]R	White	150W	21578.8Lm	5000K	IP65	100-277Vac	UL & DLC
151344	BLT-ALHL320W-50K-III-[D;N]R	White	320W	42941.5Lm	5000K	IP65	100-277Vac	UL & DLC
151638	BLT-ALHL150W-50K-III-[D;N]R	Grey	150W	21578.8Lm	5000K	IP65	100-277Vac	UL & DLC
151637	BLT-ALHL320W-50K-III-[D;N]R	Grey	320W	42941.5Lm	5000K	IP65	100-277Vac	UL & DLC
152382	BLT-ALHL320W-50K-III-ZR	Grey	320W	42941.5Lm	5000K	IP65	200-480Vac	UL & DLC

151345

Optional Photocell

## Specifications

CRI	>70
Light Efficacy	138.52Lm/W (150W) • 138.8Lm/W (320W)
Input Voltage	Universal 100-277Vac / 480Vac optional
Frequency	50/60Hz
PF	>0.92
IP rating	IP66
Operation Temperature	-20°C to 45°C
Life Span	50000 hours
Required Pole Size	60mm (top end)
Recommended Installation Height	6-8M (150W) • 10-12M (320W)

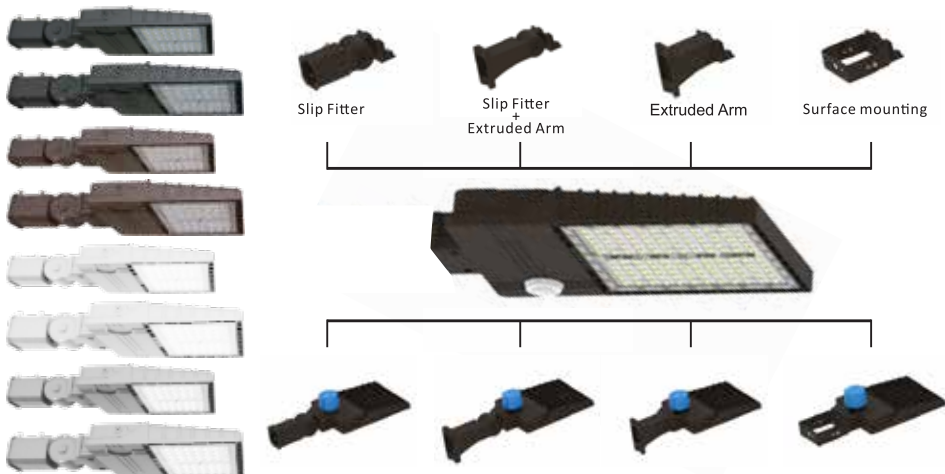

## CORRELATED COLOR TEMPERATURE (CCT)

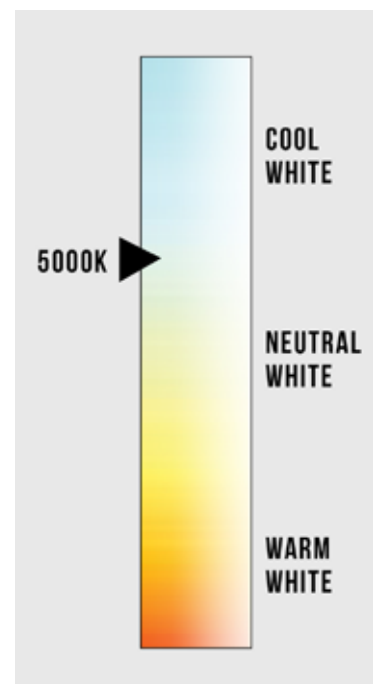

# Dimensions

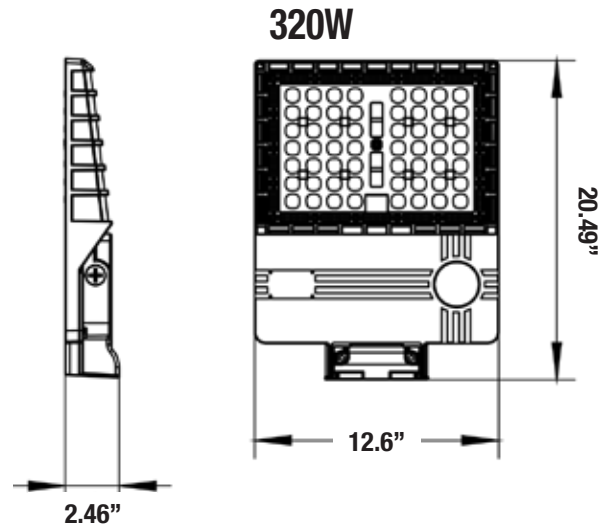
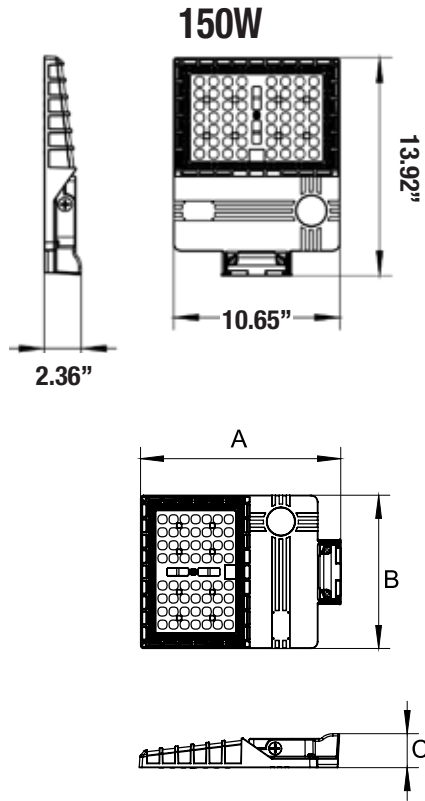

Power / Size	A	B	C
80W/100W/150W	13.92"	10.65"	2.36"
200W	16.54"	12.6"	2.46"
250W/320W	20.49"	12.6"	2.46"

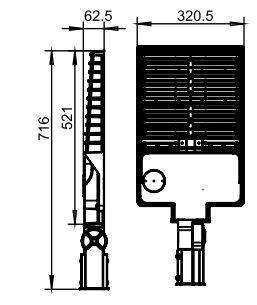
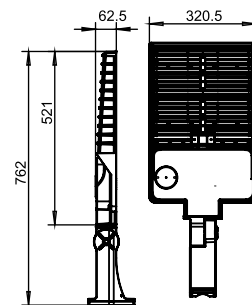
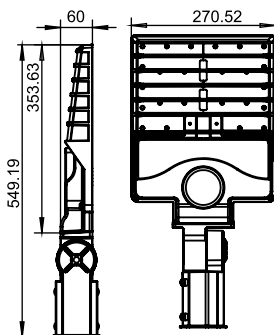
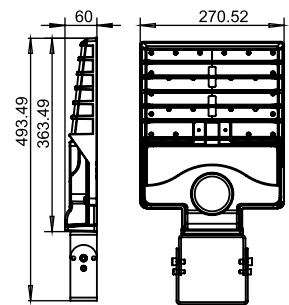
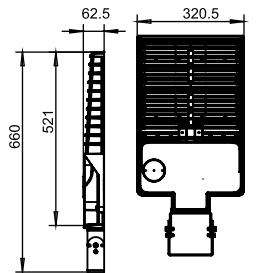
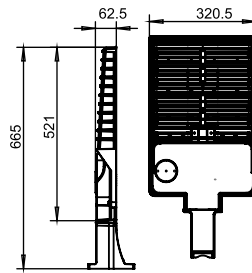
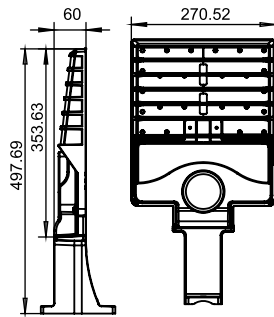
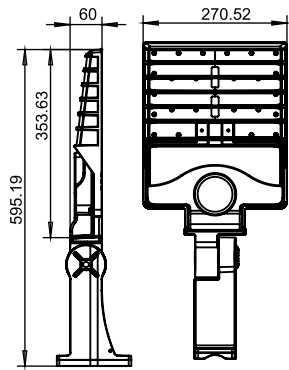

## Wiring & Features

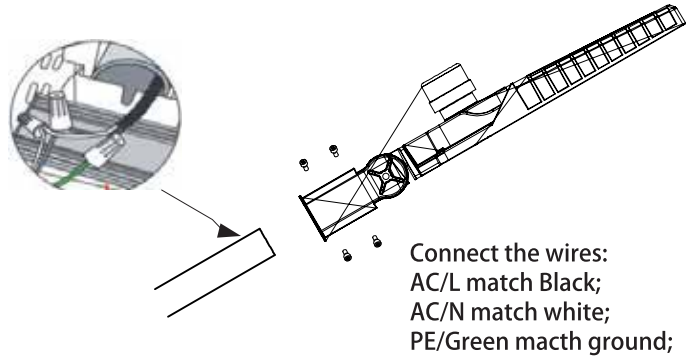

Photocell/Non-Photocell Removable  
Photocell/Non-Photocell Removable, Twist Lock for them

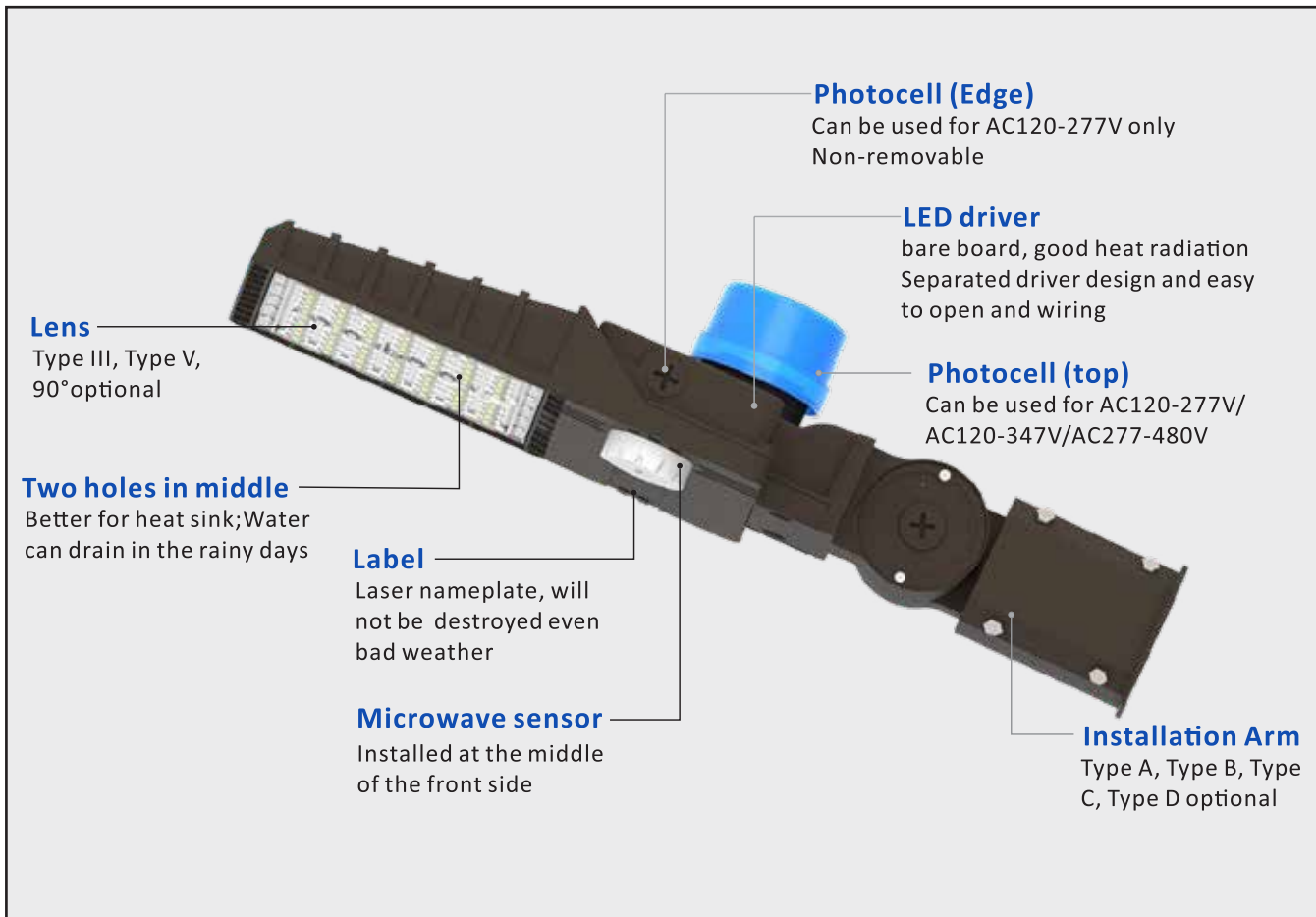
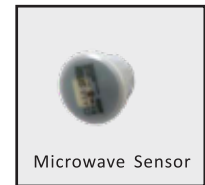

## Distribution Diagram

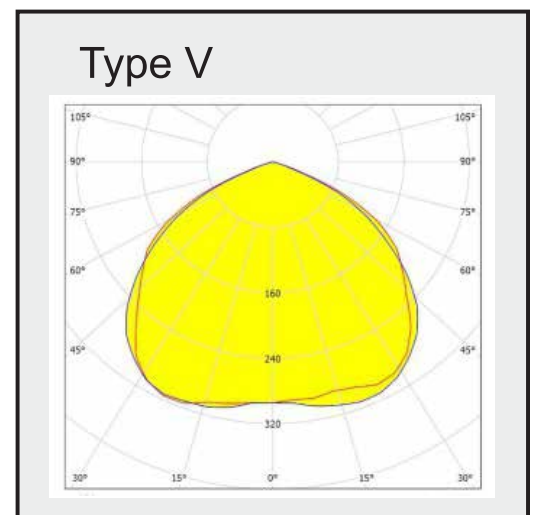
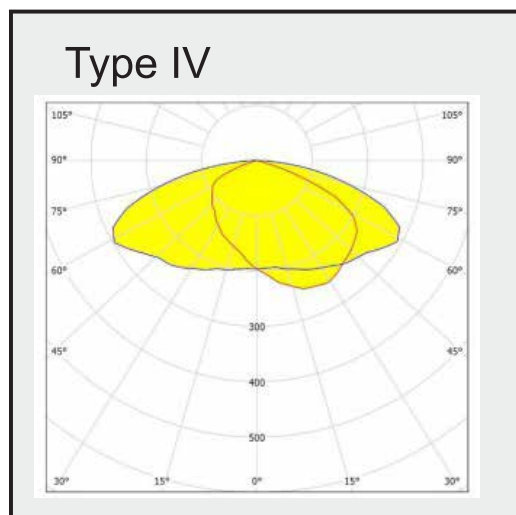
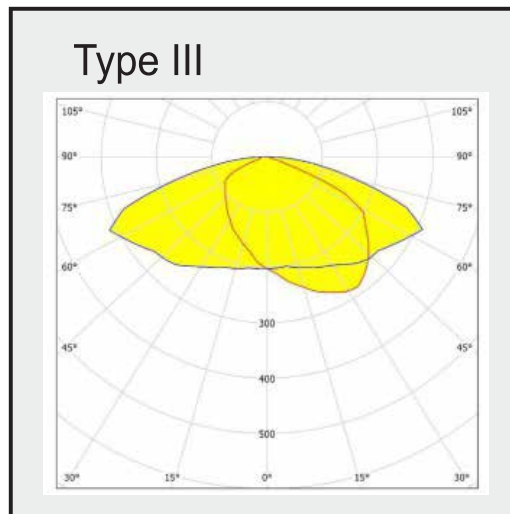
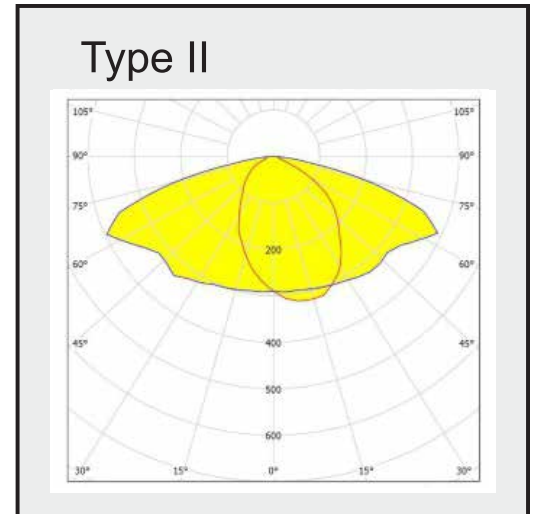
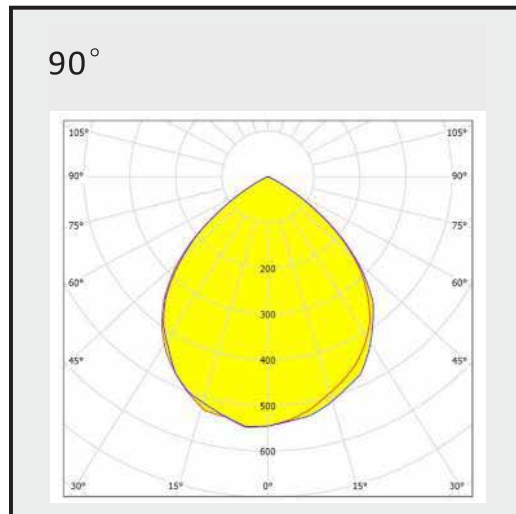

## Installation

**ALWAYS TURN OFF THE POWER SUPPLY FROM MAIN CIRCUIT BREAKER FIRST!**  
**Type A (Slip Fitter )**

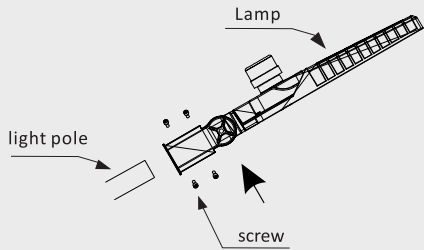

1. Attach the lamp arm to the lamp post

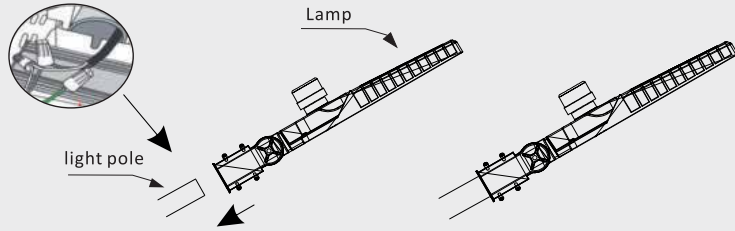

2. Connect the input wire and install the lamp on the lamp post  
Note: after lengthening the input wire, meet the height requirement of the light pole and connect the wire at the bottom of the light pole.

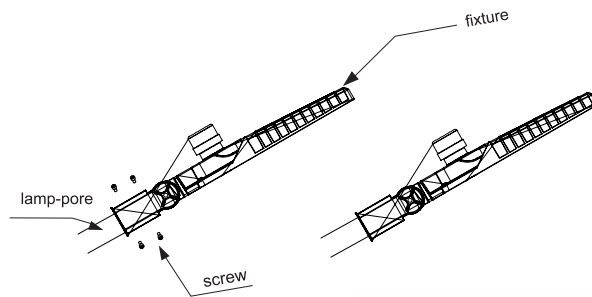

Slip Fitter

Install slip fitter on the lamp pole, wire and tighten screws



# Installation

## Type B (Slip Fitter+Extruded Arm) & Type C (Extruded Arm)

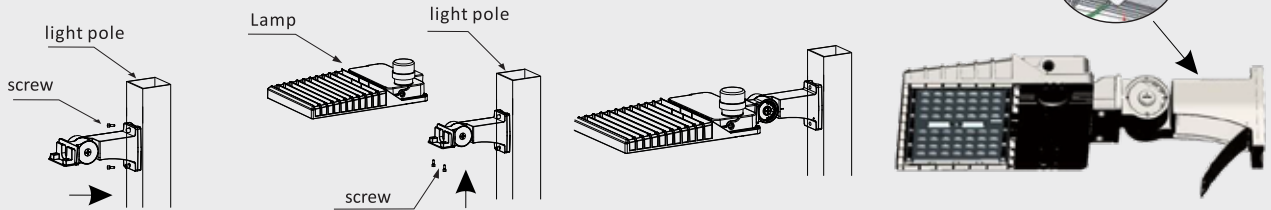

1. First install the lamp arm in the proper position of the lamp pole

2. Install the light fixture on the lamp arm

3. Lower cover of the lamp arm is opened and Complete wiring at handhole on pole. Use suitable Listed water proof cord bushing and outlet box cover.

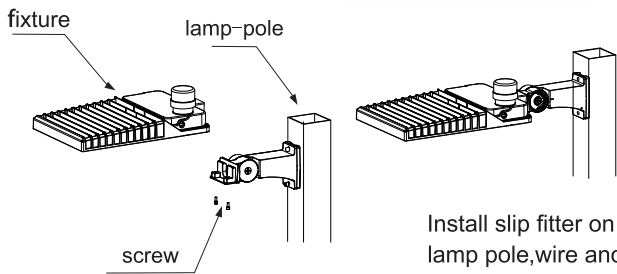

Install slip fitter on the lamp pole,wire and tighten screws

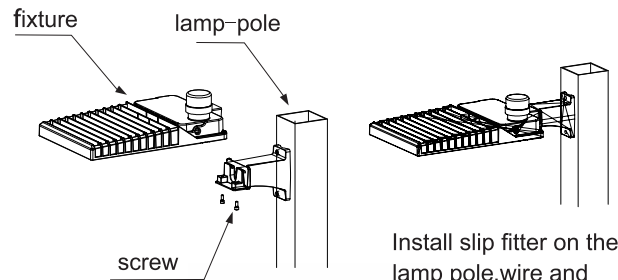

Install slip fitter on the lamp pole,wire and tighten screws

Slip Fitter + Extruded Arm



Extruded Arm



# Installation

## Type D (Surface Mount Arm)

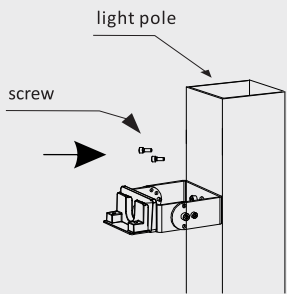

1. First install the lamp arm in the proper position of the lamp pole

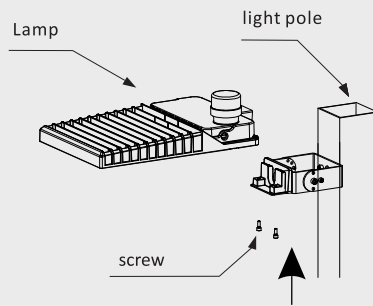

2. Install the light fixture on the lamp arm

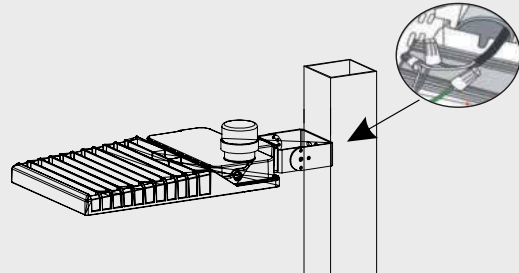

3. Lower cover of the lamp arm is opened and Complete wiring at handhole on pole. Use suitable Listed water proof cord bushing and outlet box cover.

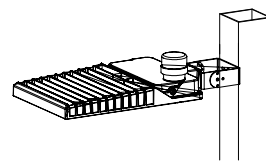
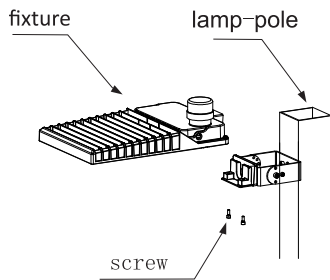

Install slip fitter on the lamp pole,wire and tighten screws

Surface mounting





# Testing

IP66 rated, suitable for wet locations



IK10 rated



Passing the testing at -40°C, can be used at cold area



## Packing

Installation Arm	Carton Dimension	Qty / Carton
Slip Fitter	24.53''*16.77''*8.7''	12PCS
Slip Fitter+Extruded Arm	24.53''*19.96''*10.83''	12PCS
Extruded Arm	21.77''*19.96''*10.83''	12PCS
Surface Mount Arm	22.32''*20.16''*6.5''	12PCS



Model	Carton Dimension	Qty / Carton	N.W	G.W	20GP	40HQ
80W	16.02 ''*12.48''*4.8''	1PCS	11.68lbs	13.49lbs	1528PCS	4203PCS
100W						
150W						
200W	18.58''*14.25*5.39''	1PCS	15.43lbs	17.20lbs	1025pcs	2820pcs
250W	22.52''*14.25''*5.39''	1PCS	20.26lbs	22.51lbs	848PCS	2332PCS
320W						



## Safety Precautions

To reduce the risk of death, personal injury or property damage from fire, electric shock, falling parts, cuts/abrasions, and other hazards read all warnings and instructions included with and on the fixture box and all fixture labels.

Before installing, servicing, or performing routine maintenance upon this equipment, follow these general precautions.

Commercial installation, service and maintenance of luminaires should be performed by a qualified licensed electrician.

For The installation: If you are unsure about the installation or maintenance of the luminaires, consult a qualified licensed electrician and check your local electrical code.

To prevent wiring damage or abrasion, do not expose wiring to edges of sheet metal or other sharp objects.

Do not make or alter any open holes in an enclosure of wiring or electrical components during kit installation.

### **WARNING: RISK OF FIRE OR ELECTRICAL SHOCK**

Turn off electrical power at fuse or circuit breaker box before wiring fixture to the power supply.

Turn off the power when you perform any maintenance.

Verify that supply voltage is correct by comparing it with the luminaire label information.

Make all electrical and grounded connections in accordance with the National Electrical Code and any applicable local code requirements.

All wiring connections should be capped with UL approved wire connectors.

### **CAUTION: RISK OF INJURY**

Avoid direct eye exposure to the light source while it is on.

Account for small parts and destroy packing material, as these may be hazardous to children.

SUITABLE FOR DRY OR DAMP LOCATION