



HPC238SC-FPH310

23.8" TFT Fanless Touch Panel Computer with Intel® Coffee Lake-S H310 Chip, Support LGA1151 35W Processor

- 1. 23.8" 250 nits brightness TFT LCD with LED backlight
- 2. 10-points Multi Capacitive Touch Panel
- 3. Design for easy Wall mount, Panel Mount, VESA Mount installation
- 4. A true Flat, easy-to-clean front surface with edge-to-edge design
- 5. Front IP65 for protection against water and dust
- 6. 12~24V DC-input Support, with EOS, OVP design



I/O Diagram

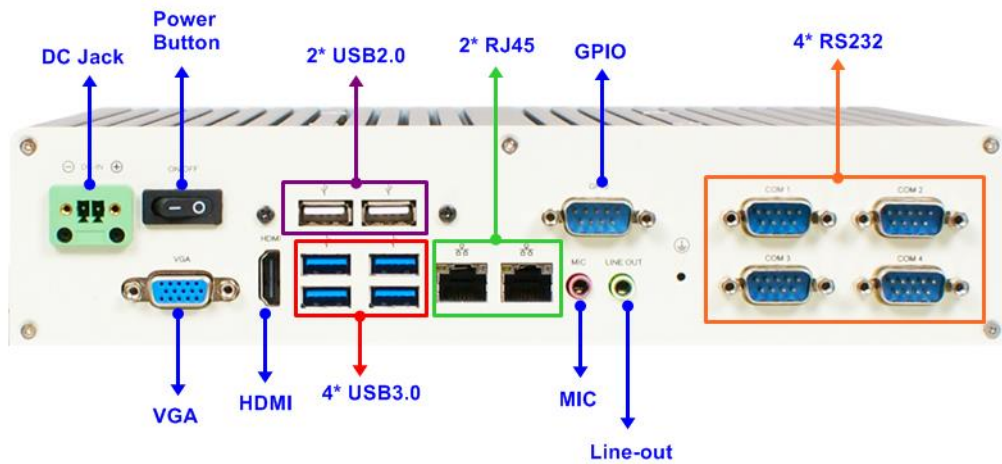

Mechanical Drawings (Unit = mm)

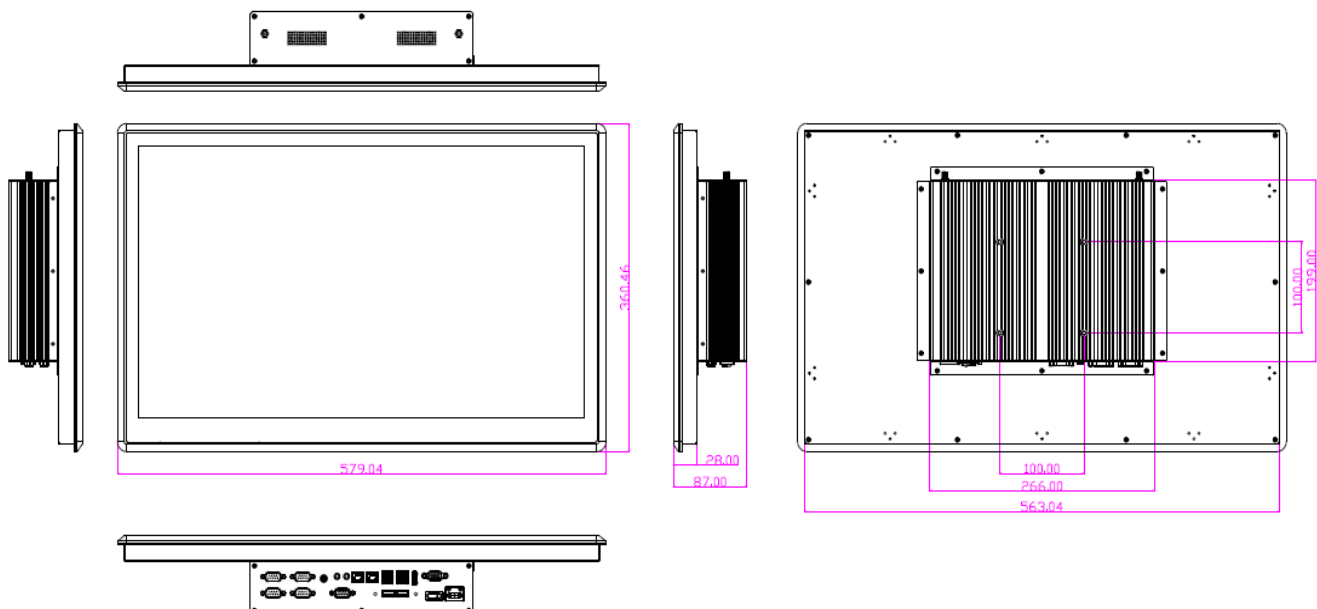

Specifications

Display

- IP65, NEMA 4 rugged protection, metal front bezel
- 23.8" With LED Backlight
- 250 nits
- 16.7M display color
- 1920 x 1080 @60Hz resolution
- 160°/160° viewing angle (H/V)
- 0.2745 x 0.2745mm pixel pitch
- 16:9 aspect ratio
- 1000:1 contrast ratio
- 25ms response time

Case

- Panel Material: Aluminum
- Iron case
- Silver + white color
- Spray paint coating requirement

Storage

- 1* 2.5" SATA HDD
- 1 * M.2 Socket (2242 M Key)

I/O Connector

- 4* USB3.0, 2* USB2.0
- 4* RS232
- 1* HDMI
- 1* VGA
- 1* 8bit GPIO (5V)
- 1* Line-out, MIC
- 2* LAN (Intel® I211AT + I219LM Gigabit LAN)
- 1* Locking Jack 12~24V DC input
- 1* Power button

Power Consumption

- 61.5W

Compliance

CE, FCC, IP65(Front)-Option

Temperature

- Operating: -10°C ~ 50°C
- Storage: -20°C ~ 70°C

Touch Screen

- Projective capacitive type
- 528.04 x 297.46mm ±0.3mm active range
- Transparency 85 ±5%
- Operating force \leq 10g
- Surface Hardness \geq 6H (ASTM D3363, pressure 1N/45°)

Main System

- Intel® LGA1151 Socket Core I3,I5,I7 Pentium T Series processor
- 2* DDR4 SO-DIMM (Max 32GB)
- 128MB SPI Flash ROM
- Speaker: 2* 3W/8Ω
- Watchdog Timer 256 levels, 0~255 sec.
- OS Support Windows 10 / Linux

Expansion

1* M.2 E Key 2230 for WIFI or 3G/4G (Support CNVi)

Power Input

- AC version: 100~240V AC-DC 60W power adapter or
- DC version: 12V DC with over current protection fuse

Dimensions

579.04 * 360.46 * 87.00mm

Safety

- Shock: 1ms duration
- Vibration: 5~500Hz/1 Grms

Warranty

2 Years Limited Warranty (Panel and Touch are only 1 Year Warrant)

* Specifications subject to change without notice, not responsible for typographical errors. Does not include HDD or OS.

Standard Accessories

Parts Number

Description

L01AS056-F Adapter 19V/6.32A 120W

Parts Number

Description

Change according to shipping area
J05-ANT-GX55240-F L-Antenna