

AVerMedia D131 series 【Preliminary】

Applies to NVIDIA® Jetson Orin™ NX/ Orin™ NANO Module



AVerMedia Technologies, Inc.

No. 135, Jian 1st Rd., Zhonghe Dist., New Taipei City 23585, Taiwan

Tel: 886-2-2226-3630

Fax: 886-2-3234-4842

Sales and Marketing: [Contact](#)

Technical Support: [Professional User](#)

Table of Contents

1.0 Introduction	9
1.1 Product Specifications	10
1.2 Option Accessory	12
2.0 Product Overview	13
2.1 Block Diagram	13
2.2 Front View and Back View of Carrier board	14
2.3 Connector Summary	15
2.4 Carrier Board Interface	16
3.0 Feature Description	17
3.1 Jetson module Connector	17
3.2 RTC Battery Connector	18
3.3 DC POWER JACK	18
3.4 HDMI OUTPUT	19
3.5 M.2 E key 2230	19
3.6 M.2 M key 2280	19
3.8 MIPI CSI-2 DPHY Lanes	20
3.9 SerDes (V-by-One® HS)	21
3.10 USB 3.2 Gen 1 Type-A Connector #1 , #2, #3	23
3.11 Gigabit Ethernet Connector	23
3.12 Jetson platform/ USB 2.0 Micro B Connector	24
3.13 Fan Power connector	24
3.14 20-Pin GPIO expansion	25
3.15 CAN Bus 3-pin terminal block with transceiver	27
3.16 ATX 4P	27
3.17 PSE Board Connector	28
3.18 Debug Port	28
3.19 OOB Board Connector	29
3.20 Force Recovery Button	30
3.21 Power on Button	30
4.0 Installation	31
4.1 BSP Setup Instructions	31
5.0 Software	32
6.0 Dimension Drawings	40
6.1 Dimension Drawings of carrier board	40
6.2 Dimension Drawing of PSE Board	41

7.0 Accessory Drawings..... 42
7.1 Fan Module/ Adapter/ Power Cord..... 42

Preface

Disclaimer

The information contained in this user manual, including but not limited to any product specification is subject to change without notice. AVerMedia assumes no liability for any damages incurred directly or indirectly from any technical or typographical errors or omissions contained herein or for discrepancies between the product and the user manual.

Technical Support

If you experience the difficulty after reading this manual and/or using the product, please contact the reseller from which you purchased the product. In most cases, the reseller can help you with the product installation and the difficulty you encountered.

In case the reseller is not able to resolve your problem, our highly capable global technical support team can certainly assist you. Our technical support section is available 24 hours a day and 7 days a week through our website, with the click [here](#). For more contact information, you may find it in the section of AVerMedia Global Offices.

Contact Enquiry

For more information of our products, pricing, and order placement, please fill in our inquiry form [here](#), we will contact you within 24 hours.

Download User Manual

Please click the link [here](#) to download the file of this user manual from AVerMedia website.

Revision History

Revision	Date	Updates
Version 0.1	March, 6, 2023	1 st Released

AVerMedia Global Offices

<https://www.avermedia.com/professional/contact-us>

Headquarters

Taiwan Office
No. 135, Jian 1st Rd., Zhonghe Dist., New Taipei
City 23585, Taiwan
Tel: +886-2-2226-3630
Fax: +886-2-3234-4842
Sales & Marketing: Contact
Technical Support: Home users / Professional
users

The Americas

USA Office
754 Charcot Avenue, San Jose, CA 95131
Sales & Marketing: Contact
Technical Support: Home users / Professional
users

Brazil Office
Sales & Marketing: Contact
Technical Support: Home users / Professional
users

Latin America Office
Sales & Marketing: Contact
Technical Support: Home users / Professional
users

Europe

Head Office EU
AVT Solutions GmbH
Hanauer Landstrasse 291 B 60314 Frankfurt
Hessen
Germany
Technical Support: Home users / Professional
users

Russia Office
Sales & Marketing: Contact
Technical Support: Home users / Professional
users
Professional Solutions Support Tel:
+7 (925) 834-0310

Spain Office
AVerMedia Information (Spain) S.L.
Ronda de Poniente no. 16 Planta Baja, Puerta K
28760 Tres cantos, Madrid, Spain
Spain:
Sales & Marketing: Contact
Technical Support: Home users / Professional
users

Asia-Pacific

China Office
Room 1510, No.488, Hitech Plaza, South Wuning
Rd., Jingan District, Shanghai, China
Tel: +86-021-5298 7985
Fax: +86-021-5298 7981
Sales & Marketing: Contact
Technical Support: Home users / Professional
users

India Office
Sales & Marketing: Contact
Technical Support: Home users / Professional
users

Japan Office
10F TOWA akihabara Bldg.1-8 Akihabara, Taito-
ku, Tokyo, 110-0006 Japan
Sales & Marketing: Contact
Technical Support: Home users / Professional
users

Thailand Office

Sales & Marketing: Contact
Technical Support: Home users / Professional
users

Korea Office
Sales & Marketing: Contact
Technical Support: Home users / Professional
users

Vietnam Office

SF, No. 596 Nguyen Dinh Chieu St., Ward 3,
District 3, HCM City, Vietnam
Tel: +84-28-22 539 211
Fax: +84-28-22 539 210
Sales & Marketing: Contact
Technical Support: Home users / Professional
users

Limited Product Warranty

AVerMedia provides product warranty. Should this product, in AVerMedia's opinion, fail to be in the good working order during the warranty period, AVerMedia will, at its option, repair or replace it at no charge, provided that the product has not been subjected to abuse, misuse, accident, disaster, or non-AVerMedia authorized modification or repair.

You may obtain the warranty service by delivering this product to an authorized AVerMedia business partner or to AVerMedia along with the proof of purchase. Product returned to AVerMedia must be pre-authorized by AVerMedia with an RMA (Return Material Authorization) number marked on the outside of the package and sent prepaid, insured, and packaged for the safe shipment. AVerMedia will return the product by prepaid shipment service.

It is not recommended to disassemble the box PC, which will impact the warranty. The limited product warranty is only valid over the serviceable life of the product. This is defined as the period during which all components are available. Should the product prove to be irreparable, AVerMedia reserves the right to substitute an equivalent product if available or to retract the product warranty if no replacement is available.

The above product warranty is the only warranty authorized by AVerMedia. Under no circumstances will AVerMedia be liable in any way for any damages, including any lost profits, lost savings, or other incidental or consequential damages arising out of the use of, or inability to use, such product.

Copyright Notice

The information contained in this document is subject to change without notice. AVerMedia shall not be liable for errors contained herein or for incidental consequential damages in connection with the furnishing, performance, or use of this material. This document contains proprietary information that is protected by copyright. All rights are reserved. No part of this document may be photocopied, reproduced, or translated to another language without the prior written consent by AVerMedia.

Trademark Acknowledgement

AVerMedia acknowledges all the trademarks, registered trademarks, and/or copyrights referred to in this document as the property of their respective owners. Not listing all possible trademarks or copyright acknowledgments does not constitute the lack of acknowledgment to the rightful owners of the trademarks and copyrights mentioned in this document.

ESD Warning

Electronic components and circuits are sensitive to Electrostatic Discharge (ESD). When handling any circuit board assemblies including AVerMedia AVerMedia products, it is highly recommended that ESD safety precautions can be observed. ESD safe best practices can include, but are not limited to the following ones.

1. Leave the circuit board in the antistatic package until it is ready to be installed.
2. Use a grounded wrist strap when handling the circuit board. At a minimum, you need to touch a grounded metal object to dissipate any static charge, which may be present on you.
3. Avoid handling the circuit board in the carpeted areas.
4. Handle the board by the edges and avoid the contact  with the components.
5. Only handle the circuit boards in ESD safe areas, which may include ESD floor and/or table mats, wrist strap stations, and ESD safe lab coats.

Safety Precaution:

1. All cautions and warnings on the device should be noted.
2. For safety consideration, do NOT open the device if not a qualified service staff.
3. Place the device on a solid surface during installation to prevent falls.
4. Keep the device away from humidity.
5. Do NOT leave this device in an un-controlled environment with temperatures beyond the device's permitted storage temperature to avoid damage.
6. All adaptors and cables supplied by AVerMedia are verified. Do NOT use any others not supplied by AVerMedia to avoid any malfunction or fires.
7. Make sure the power source matches the power rating of the device.
8. Place the power cord where people cannot step on it. Do not put anything on the power cord.
9. Always completely disconnect the power while the device is not usage or idle for a long time.

10. Disconnect the device from any AC supply before cleaning. While cleaning, use a damp cloth instead of liquid or spray detergents.
11. Make sure the device is installed near a power outlet and easy for accessible.
12. Do not cover the openings on the device to ensure optimal heat dissipation.
13. Watch out the heatsink or heat spreader of the device when the system is running.
14. Never pour any liquid into the openings. This could cause fire or electric shock.
15. The static electricity should be noted while installing any internal components. Consider to use a grounding wrist strap and put all electronic parts in static-shielded containers.

If the following situations occur, please contact our service personnel:

- (1) The device is dropped or damaged
- (2) Damaged power cord or plug
- (3) Exposure to moisture
- (4) Liquid intrusion into the device
- (5) Any obvious signs of damage displayed on the device
- (6) Device is not working as expected or in a manner as described in this manual

1.0 Introduction

AVerMedia AVerMedia D131 includes fully featured carrier board which is all developed for NVIDIA® Jetson Orin™ NX / Orin™ Nano modules. AVerMedia D131 provides not only the access to a great list of latest interfaces on NVIDIA® Jetson Orin™ NX/ Orin™ Nano modules but also 1 x GbE RJ-45 (Option PoE) & 40-pin expansion header as the function enrichment.

D131 provides one 4Kp60 HDMI video output, four USB 3.1 ports, one GbE RJ-45 port (Option POE), 40-pin expansion header , and one Micro-B USB 2.0 port for recovery.

Operating with NVIDIA® Jetson Orin™ NX/ Orin™ Nano modules and the rich I/O functions, AVerMedia D131 is the perfect choice in building a compact, high performance AI edge computing platform for the intelligent video analytics applications.

1.1 Product Specifications

Model	D131	
Type	Carrier board	
NVIDIA GPU SoC Module Compatibility	NVIDIA® Jetson Orin™ NX/ Orin™ NANO module	
Networking	1x GbE RJ-45 (PoE option) 1x M.2. key E 2230 for Wi-Fi	
Display Output	1x HDMI 2.0 (3840 x 2160 at 60Hz)	
Temperature	Operating temperature 0°C~70°C Option 0°C~60°C (PSE 802.3 AF) Storage temperature -40°C ~ 85°C Relative humidity 40 °C @ 95%, Non-Condensing	
MIPI Camera Inputs	2x 2 lane MIPI CSI-2, 15 pin FPC 1mm Pitch Connector 1x 4 lane MIPI CSI-2, 36 pin FPC 0.5mm Pitch Connector	
USB	1x USB 2.0 Micro-B for recovery 4x USB3.2 Gen1 (5G) type A	
Storage	1x M.2 key M 2280 for SSD	
Expansion Header	40-pin: 1x UART, 2x SPI, 2x I2C, 1x I2S, GPIOs	
Power requirement	Voltage	DC 9~24V
	Current	DC IN Jack on board: 7A~2.6A
		ATX 4pin: 7A~2.6A
Power adapter/Power Cord	12V/5A adapter and US/JP/EU/UK/TW/AU/CN power cord (optional)	
Fan Module	Heat sink with fan (optional)	
Buttons	Power and Recovery	
RTC Battery	Support RTC battery and Battery Life Monitoring by MCU	
PCB/Electronics Mechanical Info	113mm (W) x 105mm (L) x 28.53mm (H) Weight: 95 g	
Certifications	CE, FCC, KC (To be applied)	

Model	D1310XB	
Type	Engineering kit	
NVIDIA GPU SoC Module Compatibility	NVIDIA® Jetson Orin™ NX 8G/16G module	
Networking	1x GbE RJ-45 (PoE optional) 1x M.2. key E 2230 for Wi-Fi	
Display Output	1x HDMI 2.0 (3840 x 2160 at 60Hz)	
Temperature	Operating temperature 0°C~70°C Option 0°C~60°C (PSE 802.3 AF) Storage temperature -40°C ~ 85°C Relative humidity 40 °C @ 95%, Non-Condensing	
MIPI Camera Inputs	2x 2 lane MIPI CSI-2, 15 pin FPC 1mm Pitch Connector 1x 4 lane MIPI CSI-2, 36 pin FPC 0.5mm Pitch Connector	
USB	1x USB 2.0 Micro-B for recovery 4x USB3.2 Gen1 (5G) type A	
Storage	1x M.2. key M 2280 for SSD (256G installed)	
Expansion Header	40-pin: 1x UART, 2x SPI, 2x I2C, 1x I2S, GPIOs	
Power requirement	Voltage	DC 9~24V
	Current	DC IN Jack on board: 7A~2.6A ATX 4pin: 7A~2.6A
Power adapter/Power Cord	12V/5A adapter and US/JP/EU/UK/TW/AU/CN power cord (optional)	
Fan Module	Heat sink with fan	
Buttons	Power and Recovery	
RTC Battery	Support RTC battery and Battery Life Monitoring by MCU	
PCB/Electronics Mechanical Info	157mm(W) x 105mm(L) x 85mm(H) with stand	
Certifications	CE, FCC, KC (To be applied)	

1.2 Option Accessory

Item	D131/D131OXB
NVIDIA® Jetson	NVIDIA® Jetson Orin™ NX for D131OXB
Power adapter/Power Cord	12V/5A adapter and US/JP/EU/UK/TW/AU/CN power cord (optional)
MIPI Camera (internal I/O)	<ul style="list-style-type: none"> ● For 15 pin MIPI connector <ol style="list-style-type: none"> 1. raspberry pi camera v2 2. Manufacturer: APPRO.PHO <ul style="list-style-type: none"> ■ B-04: IMX179(8M)MIPI, 1080P(30fps) ■ C-04: IMX290(2M)MIPI, 1080P(30fps) ■ C-05: IMX290(2M)+ISP(YUV), 1080P(30fps) ● For 36 pin MIPI connector <ol style="list-style-type: none"> 1. Manufacturer: APPRO.PHO <ul style="list-style-type: none"> ■ B-03: IMX334(4K) MIPI, 4K(30fps) ■ A-06: IMX334(4K) V-by-One® HS x1,4K(30fps)

2.0 Product Overview

2.1 Block Diagram

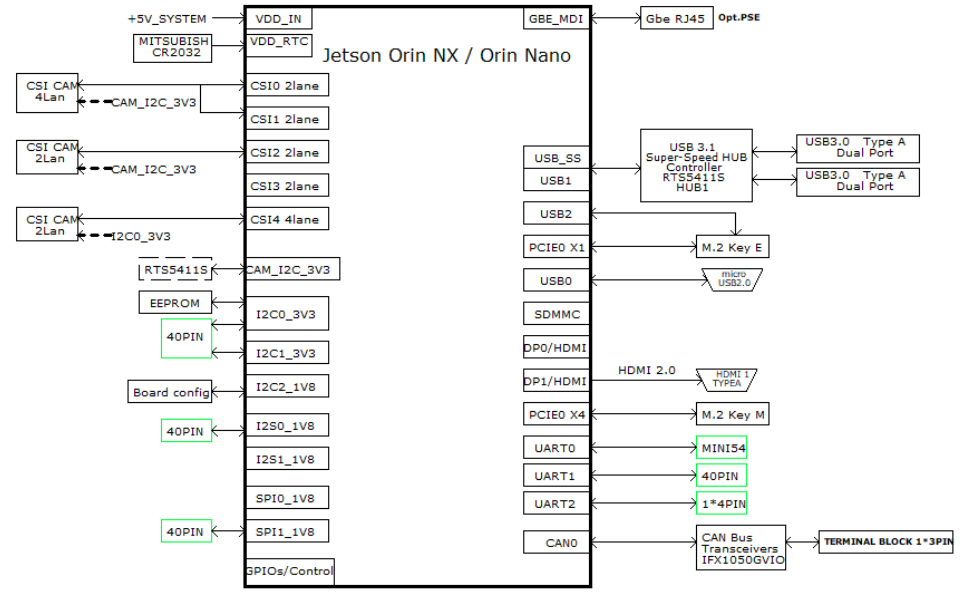

2.2 Front View and Back View of Carrier board

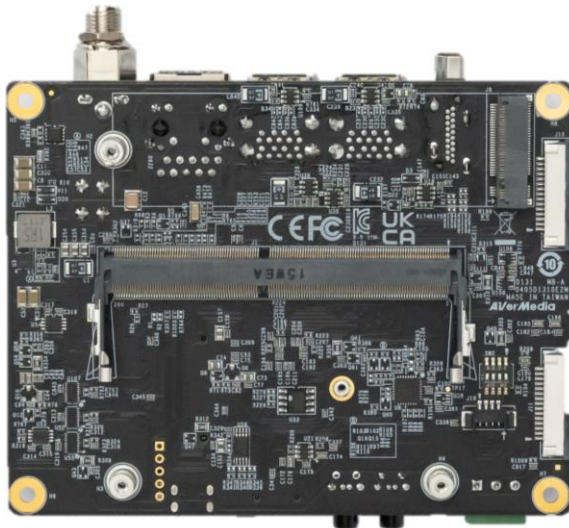
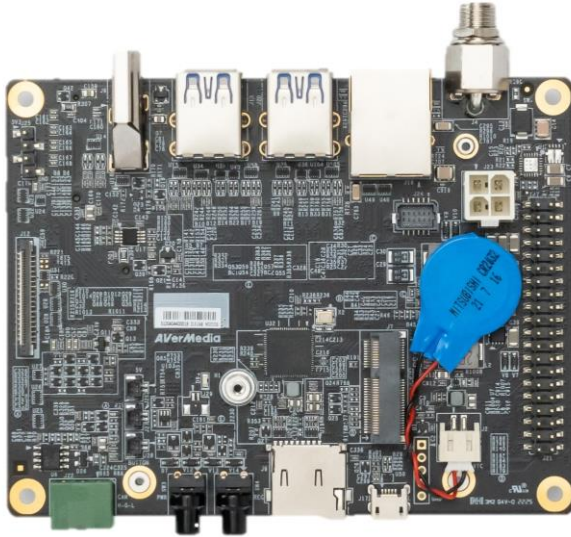

2.3 Connector Summary

J1	SO-DIMM 260-pin 90° SMD Socket(H-9.2mm) for Jetson Orin™ NX/ Orin™ Nano SOM
J2	External RTC Battery wafer
J4	DC power Jack with Lock
J6	HDMI output Type-A Vertical Side Connector (Female)
J7	M.2 E-Key Socket
J8	M.2 M-Key Socket
J10	FPC connector for 2-lane MIPI CSI-2
J11	FPC connector for 2-lane MIPI CSI-2
J12	FPC connector for 4-lane MIPI CSI-2
J13	USB 3.2 Gen1 Dual Port Type A Connector
J20	USB 3.2 Gen1 Dual Port Type A Connector
J16	RJ45 1Gb Ethernet connector (POE support optional)
J17	USB 2.0 Micro B Connector
J19	Fan Wafer
J21	40-pin Expansion
J22	CAN bus 3-pin terminal block with transceiver
J23	Input Power – 4.2mm Pitch 90° ATX Power 4P
J24	PSE Board Connector (Maximum 15W)
J25	Debug Port
J26	OOB Board Connector (5V)
J27	OOB Board Connector (Reset)
J28	OOB Board Connector (Power)
SW3	Power Button w/LEDs
SW4	Recovery Button w/LEDs

2.4 Carrier Board Interface

Top View Interface

J1	SO-DIMM 260-pin 90° SMD Socket(H-9.2mm) for Jetson Orin™ NX/ Orin™ Nano SOM
J8	M.2 M-Key Socket
J10	FPC connector for 2-lane MIPI CSI-2
J11	FPC connector for 2-lane MIPI CSI-2
J19	Fan Wafer

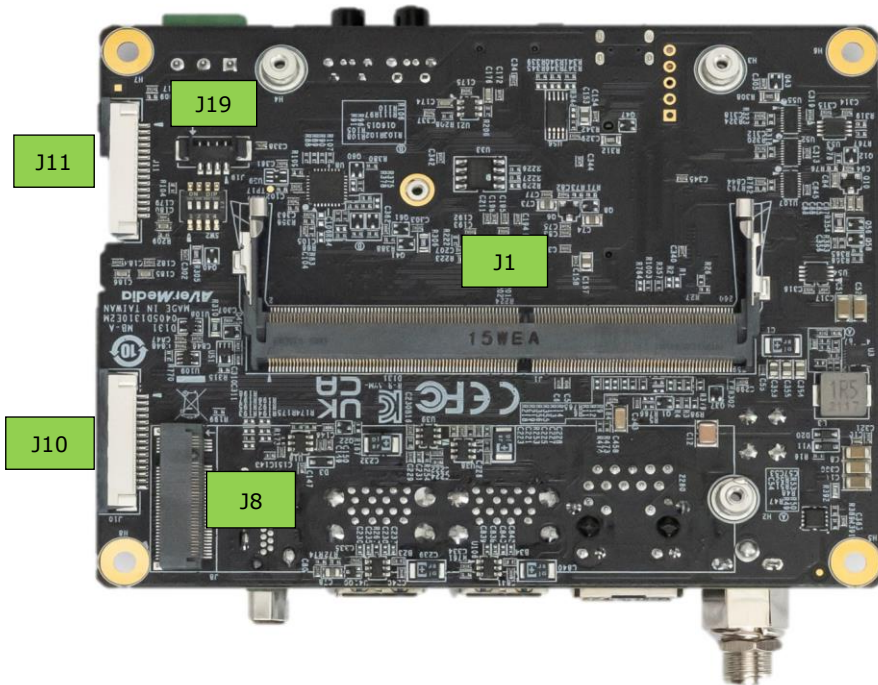

Bottom View Interface

J2	External RTC Battery wafer
J4	DC power Jack with Lock
J6	HDMI output Type-A Vertical Side Connector (Female)
J7	M.2 E-Key Socket
J12	FPC connector for 4-lane MIPI CSI-2
J13	USB 3.2 Gen1 Dual Port Type A Connector
J20	USB 3.2 Gen1 Dual Port Type A Connector
J16	RJ45 1Gb Ethernet connector (POE support optional)
J17	USB 2.0 Micro B Connector
J21	40-pin Expansion
J22	CAN bus 3-pin terminal block with transceiver
J23	Input Power – 4.2mm Pitch 90° ATX Power 4P
J24	PSE Board Connector (Maximum 15W)
J25	Debug Port
J26	OOB Board Connector (5V)
J27	OOB Board Connector (Reset)
J28	OOB Board Connector (Power)
SW3	Power Button w/LEDs
SW4	Recovery Button w/LEDs

3.0 Feature Description

3.1 Jetson module Connector

Function	Provide connection with NVIDIA® Jetson Orin™ NX module	
Location	J1	
Type Description	SOCKET_DDR4 SO-DIMM_260PIN_90°	
Manufacturer and Part Number	Foxconn ASAA826-EASB0-7H	
Mating Connector	NVIDIA® Jetson Orin™ NX	
Pinout	Please refer to NVIDIA Jetson System-on-Module datasheet for pinout details.	
Remarks	https://developer.nvidia.com/embedded/downloads	

3.2 RTC Battery Connector

Function	RTC battery for module		
Location	J2		
Type Description	2.0mm wire-to-board header 02P type		
Manufacturer and Part Number	Pinrex, 721-94-02TWR9		
Mating Connector	Tyu, TU2001HNO-02		
Pinout	Pin #	Description	
	PIN1	3V Power	
	PIN2	GND	
Remarks	RTC Battery: MITSUBISHI, CR2032 3V		

3.3 DC POWER JACK

Function	DC Power input with lock		
Location	J4		
Type Description	JACK_DC POWER_D2.5 mm_90°_DIP include nut and washer		
Manufacturer and Part Number	京政 JKCR DCD-020-105B		
Mating Connector	伸銘 SMCTS OD 5.5*2.5 mm DC 10mm (655-236)		
Pinout	Pin Number	Description	
	Center	Power	
	Outer ring	GND	
Remarks	NA		

3.4 HDMI OUTPUT

Function	HDMI output connector	
Location	J6	
Type Description	HDMI Type-A female connector	
Manufacturer and Part Number	捷湧 EDL TECHNOLOGY CO. HM-FVD480B	
Mating Connector	Any HDMI standard Type-A interface cable or device.	
Pinout	Please refer to HDMI standard.	
Remarks	None	

3.5 M.2 E key 2230

Function	M.2 E key	
Location	J7	
Type Description	SOCKET_M.2-KEY E_75PIN_90°_SMD	
Manufacturer and Part Number	宏致_ACES 51748-07502-005_P0.5 mm-H8.5 mm	
Mating Connector	Any M.2 E key 2230 card standard interface device.	
Pinout	Please refer to M.2 E key card standard for the pinout details.	
Remarks	None	

3.6 M.2 M key 2280

Function	M.2 M key	
Location	J8	
Type Description	SOCKET_M.2-KEY M_75PIN_90°_SMD	
Manufacturer and Part Number	鴻海_FOXCONN 2E0BC21-S85BM-7H_P0.5 mm-H8.5 mm	
Mating Connector	Any M.2 M key 2280 card standard interface device.	
Pinout	Please refer to M.2 M key card standard for the pinout details.	
Remarks	None	

3.8 MIPI CSI-2 DPHY Lanes

Function	MIPI camera module connector			
Location	J10 , J11			
Type Description	WAFER_15PIN_1 mm_90°			
Manufacturer and Part Number	CHAMPWAY AFA07-S15FCA-HF_FPC ZIF-LOWER			
Mating Connector	2 Lane MIPI CSI-2 camera connector (15Pin)			
Pinout	J10			
	PIN#	Description	PIN#	Description
	Pin1	GND	Pin9	CSI3_CLK_P
	Pin2	CSI3_D0_N	Pin10	GND
	Pin3	CSI3_D0_P	Pin11	CAM0_PWDN
	Pin4	GND	Pin12	CAM0_MCLK
	Pin5	CSI3_D1_N	Pin13	I2C_CAM0_SCL
	Pin6	CSI3_D1_P	Pin14	I2C_CAM0_SDA
	Pin7	GND	Pin15	+3V3_MIPI
	Pin8	CSI3_CLK_N		
	J11			
	PIN#	Description	PIN#	Description
	Pin1	GND	Pin9	CSI2_CLK_P
	Pin2	CSI2_D0_N	Pin10	GND
	Pin3	CSI2_D0_P	Pin11	CAM1_PWDN
	Pin4	GND	Pin12	CAM1_MCLK
	Pin5	CSI2_D1_N	Pin13	I2C_CAM1_SCL
	Pin6	CSI2_D1_P	Pin14	I2C_CAM1_SDA

	Pin7	GND	Pin15	+3V3_MIP1	
	Pin8	CSI2_CLK_N			

3.9 SerDes (V-by-One® HS)

Function	MIPI camera module connector	
Location	J12	
Type Description	WAFER_1*36PIN_0.5 mm_180°	
Manufacturer and Part Number	PINREX 979-44-93610A_ZIF FPC	
Mating Connector	4 Lane MIPI CSI-2 camera connector (36PIN)	

PIN OUT	Pin Number	Signal	Pin Number	Signal
	1	5V	19	GND
	2	5V	20	CSI1_D1_P
	3	1.8V	21	CSI1_D1_N
	4	3.3V	22	GND
	5	3.3V	23	N/A
	6	3.3V	24	N/A
	7	GND	25	N/A
	8	CSI0_D0_P	26	MIPI4_PWDN
	9	CSI0_D0_N	27	I2C0_ID_SDA
	10	GND	28	I2C0_ID_SCL
	11	CSI0_CLK_P	29	GND
	12	CSI0_CLK_N	30	N/A
	13	GND	31	N/A
	14	CSI0_D1_P	32	N/A
	15	CSI0_D1_N	33	N/A
	16	GND	34	GND
	17	CSI1_D0_P	35	CAM4_MCLK
	18	CSI1_D0_N	36	GND



3.10 USB 3.2 Gen 1 Type-A Connector #1 , #2, #3

Function	USB 3.2 Gen 1 Type-A connector #1 #2 #3	
Location	J13, J20	
Type Description	Dual-port USB 3.2 Gen 1 Type-A female connector	
Manufacturer and Part Number	Champway, CU3B-AFR15U-096H	
Mating Connector	Any USB 3.2 standard Type-A interface cable or device.	
Pinout	Please refer to USB 3.2 Gen 1 standard.	
Remarks	None	

3.11 Gigabit Ethernet Connector

Function	1Gb single-port Ethernet connector, used to connect to the host system.	
Location	J16	
Type Description	RJ45 with integrated magnetics	
Manufacturer and Part Number	MJ45-111QC4A-GY-S307	
Mating Connector	Any standard 1Gb Ethernet mating connector can be applicable.	
Pinout	Comply with Ethernet standards.	
Remarks	PSE Option.	

3.12 Jetson platform/ USB 2.0 Micro B Connector

Function	BSP Installation as recovery mode	 
Location	J17	
Type Description	USB micro-type B female connector	
Manufacturer and Part Number	Fullglory, FG-MCB-111440	
Mating Connector	Any USB standard Micro-type interface cable or device.	
Pinout	Please refer to USB Micro-type standard.	
Remarks	None	

3.13 Fan Power connector

Function	Fan Power Connector		
Location	J19		
Type Description	WAFER_1*4PIN_1.25 mm_90°		
Manufacturer and Part Number	ACES 50271-0040N-001_BLACK		
Mating Connector	ACES 50276-004H0H0-001		
Pinout	Pin #	Description	
	PIN 1	GND	
	PIN 2	+5V Power	
	PIN 3	FAN_TACH	
	PIN 4	FAN_PWM	
Remarks	None		

3.14 40-Pin GPIO expansion

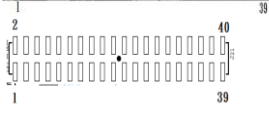

Function	General-purpose input/output	 
Location	J21	
Type Description	Expansion I/O Connector	
Manufacturer and Part Number	212-92-20GBEL	
Mating Connector	40-Pin GPIO expansion	
Pinout	D131+Orin NX	

Address	Pin Name	40-pin Index		Pin Name	Address
	3V3 VDC	1	2	5V VDC	
/dev/i2c-7 Bidirection	I2C1_SDA	3	4	5V VDC	
/dev/i2c-7 input	I2C1_SCL	5	6	GND	
gpio492 Bidirection	GPIO09_LS	7	8	UART1_TXD_LS	/dev/ttyTHS4 Input
	GND	9	10	UART1_RXD_LS	/dev/ttyTHS4 Output
gpio460 Input	UART1_RTS_LS	11	12	I2S0_SCLK_LS	gpio398 Bidirection
gpio470 Input	SPI1_SCK_LS	13	14	GND	
gpio433 Bidirection	GPIO12_LS	15	16	SPI1_CS1_LS	gpio474 Input
	GND	17	18	SPI1_CS0_LS	gpio473 Input
gpio483 Input	SPI0_MOSI_LS	19	20	GND	
gpio482 Output	SPI0_MISO_LS	21	22	SPI1_MISO_LS	gpio471 Output
gpio481 Bidirection	SPI0_SCK_LS	23	24	SPI0_CS0_LS	gpio484 Input
	GND	25	26	SPI0_CS1_LS	gpio485 Input
/dev/i2c-1 Bidirection	I2C0_ID_SDA	27	28	I2C0_ID_SCL	/dev/i2c-1 Input
gpio453 Bidirection	GPIO01_LS	29	30	GND	
gpio454 Bidirection	GPIO11_LS	31	32	GPIO07_LS	gpio389 Bidirection
gpio391 Bidirection	GPIO13_LS	33	34	GND	
gpio401	I2S0_LRCK_LS	35	36	UART1_CTS_LS	gpio461 Output
gpio472 Input	SPI1_MOSI_LS	37	38	I2S0_SDIN_LS	gpio400 Input
	GND	39	40	I2S0_SDOOUT_LS	gpio399 Output

3.15 CAN Bus 3-pin terminal block with transceiver

Function	CAN Bus 3-pin terminal block with transceiver		 <table border="1" data-bbox="866 497 1009 541"> <tr> <td>3</td> <td>2</td> <td>1</td> </tr> </table>	3	2	1
3	2	1				
Location	J22					
Type Description	TERMINAL BLOCK_1*3PIN					
Manufacturer and Part Number	進聯 DECA, ME030-38103T, GREEN-P3.81 mm					
Mating Connector	進聯 DECA, MC420-38103Z					
Pinout	Pin #	Description				
	1	CANH				
	2	GND				
	3	CANL				
Remarks	None					

3.16 ATX 4P

Function	ATX 4P		 
Location	J23		
Type Description	WAFER_2*2PIN_4.2 mm_90°_DIP		
Manufacturer and Part Number	福軒 Fullglory FPWD-42R2-04NAT		
Mating Connector	Follow ATX 4pin power standard		
Pinout	Pin Number	Description	
	1	GND	
	2	GND	
	3	9-24V Power	
	4	9-24V Power	
Remarks	None		

3.17 PSE Board Connector.

Function	PSE Board Connector.				
Location	J24				
Type Description	WAFER_2*6PIN_1 mm_180°_SMD				
Manufacturer and Part Number	ACES 50238-01241-001				
Pinout	PIN#	Description	PIN#		Description
	Pin1	PWR_IN	Pin2		GND
	Pin3	PWR_IN	Pin4		GND
	Pin5	54V	Pin6		SYS_RST*
	Pin7	54V	Pin8		I2C1_SCL *
	Pin9	PortN_OUT0	Pin10		I2C1_SDA
	Pin11	POE_P0	Pin12		3V3
Remarks	NA				

3.18 Debug Port

Function	Debug			
Location	J25			
Type Description	1*4PIN_2.54 mm_180°_SMD			
Manufacturer and Part Number	ACES 60240-00471-001			
Pinout	Pin #	Description		
	PIN1	3V3 Power		
	PIN2	UART_TXD		
	PIN3	UART_RXD		
	PIN4	GND		
Remarks				

3.19 OOB Board Connector.

Function	OOB Board Connector (5V)		
Location	J26		
Type Description	WAFER_1*2PIN_1 mm_180°_SMD		
Manufacturer and Part Number	ACES 50228-00271-001		
Pinout	Pin #	Description	
	PIN1	5V	
	PIN2	GND	
Remarks			

Function	OOB Board Connector (Reset)		
Location	J27		
Type Description	WAFER_1*2PIN_1 mm_180°_SMD		
Manufacturer and Part Number	ACES 50228-00271-001		
Pinout	Pin #	Description	
	PIN1	SYS_RST*_AI	
	PIN2	GND	
Remarks			

Function	OOB Board Connector (Power)		
Location	J28		
Type Description	WAFER_1*2PIN_1 mm_180°_SMD		
Manufacturer and Part Number	ACES 50228-00271-001		
Pinout	Pin #	Description	
	PIN1	BUTTON_ON	
	PIN2	GND	
Remarks			

3.20 Power control button

Function	Power control button	
Location	SW3	
Type Description	Button	
Manufacturer and Part Number	Champway LS67AK-NBR-A-R2KA9	
Pinout	N/A	
Remark	None	

3.21 Force recovery Button

Function	Force recovery	
Location	SW4	
Type Description	Button	
Manufacturer and Part Number	Champway LS67AK-NBR-A-R2KA9	
Pinout	N/A	
Remark	None	

Other Switches and Jumpers

Other switches and jumpers listed on the boards but not mentioned in this manual are reserved for the internal use by AVerMedia. They are not open to the client application.

4.0 Installation

1. Check and ensure all the external system power supplies are turned off.
2. Install the Micro USB2.0 cable to Jetson platform connector.
3. Press and hold on the Recover button.
4. Connect the power cord to the box PC.

4.1 BSP Setup Instructions

BSP (board support package) file: D131OX-R2.0*.tar.gz for D131OX

If you want to get the BSP download link, Please contact with AVerMedia FAE.

Default login username/password of the BSP is nvidia/nvidia

If you have difficulties to access the BSP download link, please visit AVerMedia website at <https://www.avermedia.com/professional/download>, or contact technical support at https://www.avermedia.com/professional/technical_support or e-mail us at eusupport@avermedia.com for further assistance.

BSP Installation steps for NVIDIA Jetson board: (Important Note: Please backup your personal files before re-flashing BSP)

After you download the BSP file and put the file in a Linux PC, please refer to the steps below to re-flash BSP.

1. Let the JETSON Orin NX initiate recovery mode.

You have to keep pressing “Recovery” button and then power on the NVIDIA Jetson board to initiate recovery mode.

When connecting a NVIDIA Jetson board to a Linux PC via a MicroUSB to USB cable, you can check kernel messages with `dmesg` command in the Linux PC.

Once you see these messages in the kernel messages, this means that the NVIDIA Jetson board is in the recovery mode.

```
[24685.229129] usb 1-7: Product: APX
```

```
[24685.229132] usb 1-7: Manufacturer: NVIDIA Corp
```

2. Using the commands below in the Linux PC to start re-flashing BSP.

```
$ sudo tar zxvf D131OX-R2.*.*.tar.gz
(file: D131OX-R2.*.*.tar.gz for D131OXB)
$ cd JetPack_*.*/Linux_for_Tegra
$ sudo ./install.sh
```

The BSP is support flash to default nvme ssd or external USB dungle.

You can select which one you want to flash after launching the install script.

Note: sudo is required to re-flash the BSP..

5.0 Software

This section describes BSP's features for D131OXB

1. Support optional M.2 WI-FI/Bluetooth modules (Intel® Wireless-AC 9260), the manager UI of AC9260 WiFi/Bluetooth is located on the upper-right corner of Ubuntu desktop. It can be also controlled by nmcli/hcitol in command line.
2. Support SD slot (D131OX is not support SD card slot.)
3. Power Mode
Power mode can be modified by the UI on the upper-right corner of Ubuntu or the following commands.

```
# get current power mode
$ sudo nvpmode -q
# setup power mode
# where <x> is power mode number, please refer to
https://docs.nvidia.com/jetson/archives/r35.2.1/DeveloperGuide/index.html#page/Tegra%20Linux%20Driver%20Package%20Development%20Guide/clock\_power\_setup.html for more information
$ sudo nvpmode -m <x>
```

* Current default power mode:

D131OX: MODE 15W DESKTOP (2)

4. RTC Battery
The following command can get RTC battery voltage.

```
$ sudo avt tool -a | grep -oP "AIN5.*\[\K[\^]]*"
```

5. Fan Speed

The following commands can get PWM fan information.

```
# get Fan RPM value
$ cat /sys/devices/platform/gpio_tachometer/hwmon/hwmon1/gpiotach_rpm
```

6. CAN Bus

There are one CAN Bus for D131OXB, see the following command for usage.

(1) Enable and setup CAN Bus

```
# 1. Enable CAN Bus
$ sudo modprobe can
$ sudo modprobe can-raw
$ sudo modprobe mttcan
# 2. Setup CAN Bus
$ sudo ip link set can0 type can bitrate 500000 dbitrate 2000000 berr-reporting on
fd on restart-ms 100
$ sudo ip link set can0 up
```

(2) Receive and Send

```
# Receive
$ candump can0

# Send
$ cansend can0 <can frame>
```

* where:

<can_frame> is CAN Bus frame message, see `cansend --help` for more detail.

7. MIPI CSI Camera

There are 2x 2-lane and 1x 4-lane MIPI CSI camera supported on D1310XB, for current supported products type are listing as below:

- * IMX219 (2-lane)
- * IMX477 (2-lane)
- * IMX179 (2-lane)
- * IMX290 (2-lane)
- * IMX290ISP (2-lane)
- * IMX334 (4-lane)
- * IMX334THCV (4-lane)

Test Command:

```

> Raspberry pi v2 :
  No width height framerate
  0 3264 2464 21
  1 3264 1848 28
  2 1920 1080 30
  3 1640 1232 30
  4 1280 720 60
  $ gst-launch-1.0 nvarguscamerasrc sensor-id=0 sensor-mode=0 ! 'video/x-raw(memory:NVMM), width=(int)3264, height=(int)2464, format=(string)NV12, framerate=(fraction)21/1' ! nvvidconv ! xvimagesink -e
  $ gst-launch-1.0 nvarguscamerasrc sensor-id=0 sensor-mode=1 ! 'video/x-raw(memory:NVMM), width=(int)3264, height=(int)1848, format=(string)NV12, framerate=(fraction)28/1' ! nvvidconv ! xvimagesink -e
  $ gst-launch-1.0 nvarguscamerasrc sensor-id=0 sensor-mode=2 ! 'video/x-raw(memory:NVMM), width=(int)1920, height=(int)1080, format=(string)NV12, framerate=(fraction)30/1' ! nvvidconv ! xvimagesink -e
  $ gst-launch-1.0 nvarguscamerasrc sensor-id=0 sensor-mode=3 ! 'video/x-raw(memory:NVMM), width=(int)1640, height=(int)1232, format=(string)NV12, framerate=(fraction)30/1' ! nvvidconv ! xvimagesink -e
  $ gst-launch-1.0 nvarguscamerasrc sensor-id=0 sensor-mode=4 ! 'video/x-raw(memory:NVMM), width=(int)1280, height=(int)720, format=(string)NV12, framerate=(fraction)60/1' ! nvvidconv ! xvimagesink -e

  Multiple:
  $ gst-launch-1.0 nvarguscamerasrc sensor-id=0 sensor-mode=0 ! 'video/x-raw(memory:NVMM), width=(int)3264, height=(int)2464, format=(string)NV12, framerate=(fraction)21/1' ! nvvidconv ! xvimagesink -e & gst-launch-1.0 nvarguscamerasrc sensor-id=1 sensor-mode=0 ! 'video/x-raw(memory:NVMM), width=(int)3264, height=(int)2464, format=(string)NV12, framerate=(fraction)21/1' ! nvvidconv ! xvimagesink -e &

> Raspberry pi v3 (imx477):
  No width height framerate
  0 4032 3040 30
  1 1920 1080 60
  
```

```
$ gst-launch-1.0 nvarguscamerasrc sensor-id=0 ! "video/x-raw(memory:NVMM),width=4032,height=3040,framerate=30/1" ! nvvidconv ! xvimagesink -e
```

```
$ gst-launch-1.0 nvarguscamerasrc sensor-id=0 ! "video/x-raw(memory:NVMM),width=1920,height=1080,framerate=60/1" ! nvvidconv ! xvimagesink -e
```

Multiple:

```
$ gst-launch-1.0 nvarguscamerasrc sensor-id=0 ! "video/x-raw(memory:NVMM),width=1920,height=1080,framerate=60/1" ! nvvidconv ! xvimagesink -e & gst-launch-1.0 nvarguscamerasrc sensor-id=1 ! "video/x-raw(memory:NVMM),width=1920,height=1080,framerate=60/1" ! nvvidconv ! xvimagesink -e &
```

> IMX179 :

No	width	height	framerate
0	3280	2464	15
1	1920	1080	30
2	3280	1698	30
3	2096	1084	30
4	1640	1232	30
5	820	616	30
6	820	616	60

```
$ gst-launch-1.0 nvarguscamerasrc sensor-id=0 sensor-mode=0 ! 'video/x-raw(memory:NVMM), width=(int)3280, height=(int)2464, format=(string)NV12, framerate=(fraction)15/1' ! nvvidconv ! xvimagesink -e
```

```
$ gst-launch-1.0 nvarguscamerasrc sensor-id=0 sensor-mode=1 ! 'video/x-raw(memory:NVMM), width=(int)1920, height=(int)1080, format=(string)NV12, framerate=(fraction)30/1' ! nvvidconv ! xvimagesink -e
```

```
$ gst-launch-1.0 nvarguscamerasrc sensor-id=0 sensor-mode=2 ! 'video/x-raw(memory:NVMM), width=(int)3280, height=(int)1698, format=(string)NV12, framerate=(fraction)30/1' ! nvvidconv ! xvimagesink -e
```

```
$ gst-launch-1.0 nvarguscamerasrc sensor-id=0 sensor-mode=3 ! 'video/x-raw(memory:NVMM), width=(int)2096, height=(int)1084, format=(string)NV12, framerate=(fraction)30/1' ! nvvidconv ! xvimagesink -e
```

```
$ gst-launch-1.0 nvarguscamerasrc sensor-id=0 sensor-mode=4 ! 'video/x-raw(memory:NVMM), width=(int)1640, height=(int)1232, format=(string)NV12, framerate=(fraction)30/1' ! nvvidconv ! xvimagesink -e
```

```
$ gst-launch-1.0 nvarguscamerasrc sensor-id=0 sensor-mode=5 ! 'video/x-raw(memory:NVMM), width=(int)820, height=(int)616, format=(string)NV12, framerate=(fraction)30/1' ! nvvidconv ! xvimagesink -e
```

```
$ gst-launch-1.0 nvarguscamerasrc sensor-id=0 sensor-mode=6 ! 'video/x-raw(memory:NVMM), width=(int)820, height=(int)616, format=(string)NV12, framerate=(fraction)60/1' ! nvvidconv ! xvimagesink -e
```

Control Focus:

```
$ v4l2-ctl -d /dev/video2 --set-ctrl=focus_manual=1
$ v4l2-ctl -d /dev/video2 --set-ctrl=focus_manual=1024

> IMX290 :
No width height framerate
0 1948 1096 30
1 1948 1096 60

$ gst-launch-1.0 nvarguscamerasrc sensor-id=0 sensor-mode=0 ! 'video/x-raw(memory:NVMM), width=(int)1948, height=(int)1096, format=(string)NV12, framerate=(fraction)30/1' ! nvvidconv ! xvimagesink -e
$ gst-launch-1.0 nvarguscamerasrc sensor-id=0 sensor-mode=1 ! 'video/x-raw(memory:NVMM), width=(int)1948, height=(int)1096, format=(string)NV12, framerate=(fraction)60/1' ! nvvidconv ! xvimagesink -e

> IMX290ISP :
No width height framerate
0 1920 1080 25/30/50/60
1 1280 960 25/30/50/60
2 1280 720 25/30/50/60
0 800 600 25/30/50/60
1 640 480 25/30/50/60
2 640 360 25/30/50/60

$ gst-launch-1.0 v4l2src io-mode=4 device=/dev/video0 do-timestamp=true ! 'video/x-raw, width=1920, height=1080, framerate=30/1, format=UYVY' ! xvimagesink sync=false
$ gst-launch-1.0 v4l2src io-mode=4 device=/dev/video0 do-timestamp=true ! 'video/x-raw, width=1280, height=720, framerate=30/1, format=UYVY' ! xvimagesink sync=false
$ gst-launch-1.0 v4l2src io-mode=4 device=/dev/video0 do-timestamp=true ! 'video/x-raw, width=1280, height=960, framerate=30/1, format=UYVY' ! xvimagesink sync=false
$ gst-launch-1.0 v4l2src io-mode=4 device=/dev/video0 do-timestamp=true ! 'video/x-raw, width=1920, height=1080, framerate=60/1, format=UYVY' ! xvimagesink sync=false
$ gst-launch-1.0 v4l2src io-mode=4 device=/dev/video0 do-timestamp=true ! 'video/x-raw, width=1280, height=720, framerate=60/1, format=UYVY' ! xvimagesink sync=false
$ gst-launch-1.0 v4l2src io-mode=4 device=/dev/video0 do-timestamp=true ! 'video/x-raw, width=1280, height=960, framerate=60/1, format=UYVY' ! xvimagesink sync=false

> IMX334 :
No width height framerate
0 3864 2180 30
```

```
1 3864 2180 60
2 1944 1090 30
3 1944 1090 60
```

```
$ gst-launch-1.0 nvarguscamerasrc sensor-id=0 sensor-mode=0 ! 'video/x-raw(memory:NVMM), width=(int)3864, height=(int)2180, format=(string)NV12, framerate=(fraction)30/1' ! nvvidconv ! xvimagesink -e
```

```
$ gst-launch-1.0 nvarguscamerasrc sensor-id=0 sensor-mode=1 ! 'video/x-raw(memory:NVMM), width=(int)3864, height=(int)2180, format=(string)NV12, framerate=(fraction)60/1' ! nvvidconv ! xvimagesink -e
```

```
$ gst-launch-1.0 nvarguscamerasrc sensor-id=0 sensor-mode=2 ! 'video/x-raw(memory:NVMM), width=(int)1944, height=(int)1090, format=(string)NV12, framerate=(fraction)30/1' ! nvvidconv top=5 bottom=1085 left=12 right=1932 ! xvimagesink -e
```

```
$ gst-launch-1.0 nvarguscamerasrc sensor-id=0 sensor-mode=3 ! 'video/x-raw(memory:NVMM), width=(int)1944, height=(int)1090, format=(string)NV12, framerate=(fraction)60/1' ! nvvidconv top=5 bottom=1085 left=12 right=1932 ! xvimagesink -e
```

> IMX334 V-by-One (imx334thcv):

```
No width height framerate
0 3864 2180 30
1 1944 1090 30
2 1944 1090 60
```

```
$ gst-launch-1.0 nvarguscamerasrc sensor-id=0 sensor-mode=0 ! 'video/x-raw(memory:NVMM), width=(int)3864, height=(int)2180, format=(string)NV12, framerate=(fraction)30/1' ! nvvidconv ! xvimagesink -e
```

```
$ gst-launch-1.0 nvarguscamerasrc sensor-id=0 sensor-mode=1 ! 'video/x-raw(memory:NVMM), width=(int)1944, height=(int)1090, format=(string)NV12, framerate=(fraction)30/1' ! nvvidconv top=5 bottom=1085 left=12 right=1932 ! xvimagesink -e
```

```
$ gst-launch-1.0 nvarguscamerasrc sensor-id=0 sensor-mode=2 ! 'video/x-raw(memory:NVMM), width=(int)1944, height=(int)1090, format=(string)NV12, framerate=(fraction)60/1' ! nvvidconv top=5 bottom=1085 left=12 right=1932 ! xvimagesink -e
```

8. GPIO usage

(1) Output: (e.g. gpio232)

```
$ sudo su
$ gpio_id=232
$ echo $gpio_id > /sys/class/gpio/export
$ echo out > /sys/class/gpio/gpio$gpio_id/direction
$ echo 1 > /sys/class/gpio/gpio$gpio_id/value # HIGH
```

```
$ echo 0 > /sys/class/gpio/gpio$gpio_id/value # LOW
```

(2) Input

```
$ sudo su
$ gpio_id=232
$ echo $gpio_id > /sys/class/gpio/export
$ echo in > /sys/class/gpio/gpio$gpio_id/direction
$ cat /sys/class/gpio/gpio$gpio_id/value # 1: HIGH, 0: LOW
```

(3) Disable

```
$ sudo su
$ gpio_id=232
$ echo $gpio_id > /sys/class/gpio/unexport
```

For L4T (Linux for Tegra) BSP support and the other software support associated with NVIDIA® Jetson Orin NX, please visit AVerMedia website to contact our technical support function. (<https://www.avermedia.com/tw/support/contact>)

9. Force Recovery Mode

USB 3.1/ Jetson platform port of D1310XB can be used to re-program NVIDIA® Jetson Orin NX by using the other host system running NVIDIA Jetpack, as the procedure described below.

1. Power off the system. Ensure the system power must be completely OFF, instead of staying in the suspend mode or the sleep mode.
2. Connect a USB cable from Jetson platform USB port to the other host system which will be used to re-program the new system file into NVIDIA® Jetson Orin NX.
3. Press and hold down Force Recovery Button and then power on the carrier board.
4. After three seconds, release Force Recovery Button.
5. NVIDIA® Orin NX will show up on the USB list of the host system as a new NVIDIA target device.

After the system software is updated successfully, please ensure to power off the system. A clean power-on will then revert Jetson platform port back to the host mode

10. Power Consumption

Item Description	Power Consumption
<p>Theoretical Maximum System Power Consumption</p>	<ul style="list-style-type: none"> ● D1310XB Power Consumption: TBD <p>The condition is connected to USB3.2*4,USB*1,MIPI 2 lane*2, 4 lane *1, SSD 256G*1,Wifi 9260*1, HDMI*1, with CPU/ GPU full loading. (maximum power consumption up to 60W based on adapter)</p>
<p>Typical System Power Consumption</p>	<p>The power consumption under the normal operating mode is depending on the application software running with NVIDIA® Orin™ NX</p>

6.0 Dimension Drawings

6.1 Dimension Drawings of carrier board

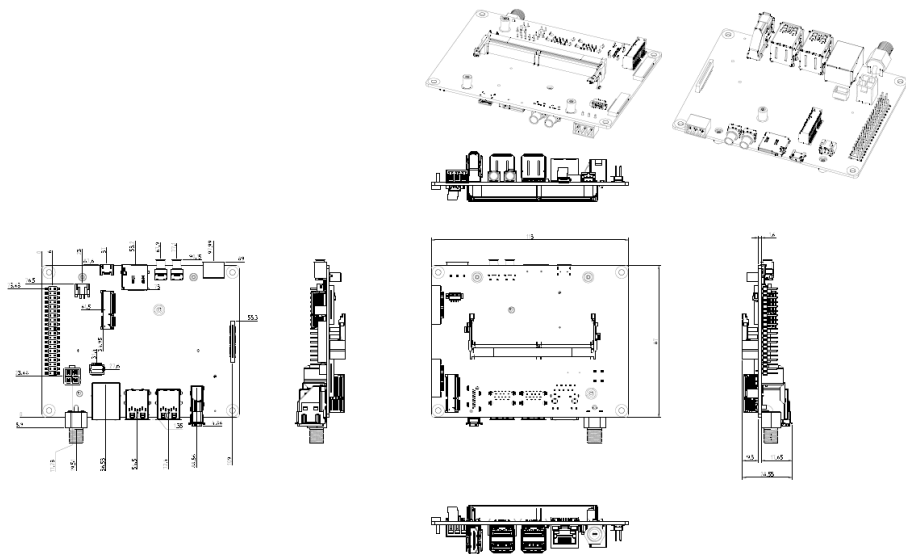

6.2 Dimension Drawing of PSE Board

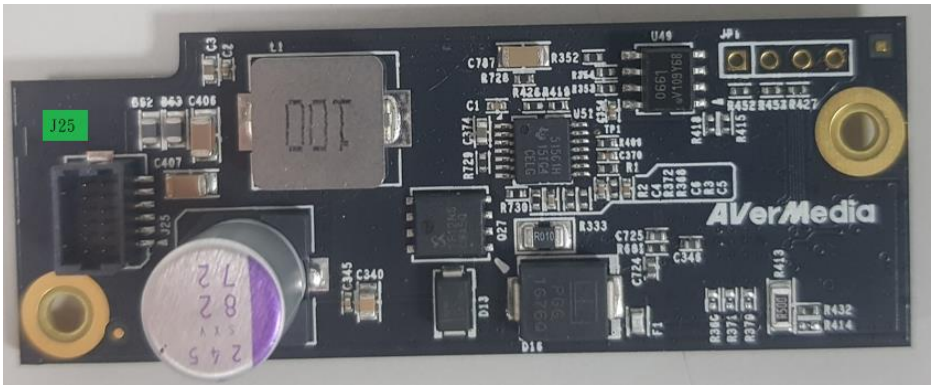
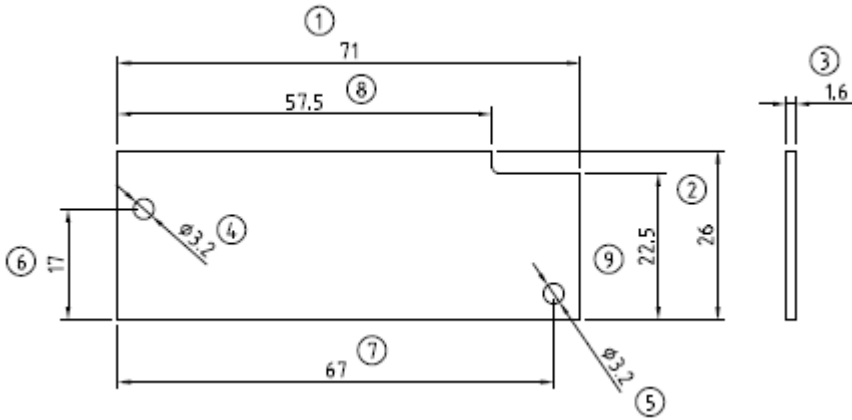

7.0 Accessory Drawings

7.1 Fan Module/ Adapter/ Power Cord

Fan Module for Orin NX

- Rated Voltage: 5V
- Operating Voltage Range: 3.5V~5.5V
- Rated Speed: 7000RPM±10%
(Testing Speed After Continuous 3 Minute Operation At Ambient Temperature Of 25°C)
- Life Expectancy: 70,000hours at 40°C (WITH 15~65% RH)
- Bearing Type: Two Ball

版次	修改內容敘述	日期
▲	發行	2022/01/04

白色矽子頭，請注意風扇出線方向，線長125±10mm

Grease 7762_122.26x20.16@.25mm

註釋：

- 1.此圖僅有組合重製之尺寸，各零件之詳細資訊請參照3D與零件CAD檔案。
- 2.所有尺寸公差是依據美國國家標準會所制定。
- 3.產品所使用之材料必須符合RoHS規範。
- 4.生產時零件產品必須量測所有尺寸QAD確認是否正確，在出貨前請確認此產品的批次是否正確。
- 5.設備零件生產承認程序(PPAP)，需附MCPK檢驗此產品材料能力(CP/CPK)。
- 6.△標記為關鍵尺寸，需依照此檢驗程序進行製成力CP/CPK檢驗。
- 7.其他尺寸及沒有標記尺寸之檢驗皆依據圖面公差對照表加以管理。
- 8.產品外觀清潔度淨度且不能有污漬、油、漆、遺棄、或任何污物。
- 9.產品必須檢驗以確保在裝機時防止損傷。
- 10.檢驗標識必須位於明顯處，此檢驗標識之尺寸格式依QAD/圖面及客戶標識。
- 11.單體在外安裝的邊角必須經過修整處理成為可觸摸且符合工藝標準範圍中，毛邊不可大於材料厚度的10%。
- 12.包裝規格：紙箱，一箱20 PCS，共計1000PCS/箱。

線序參考：朝向參照風扇規格書

LABEL 1:3

17

QP06 B09095
95D0001A01

QR Code: QP09
QP06B0909501A01

附件配件: Spring Screw *4 pcs

英號及英寸		英號及英寸	
公稱	品號	品號	品名
0-10	A3L	QP06B09095	風扇
10-50	3L15		零件
50-100	A3L		零件
100-	3L25		零件

064APOWBR2-IPD (US version)

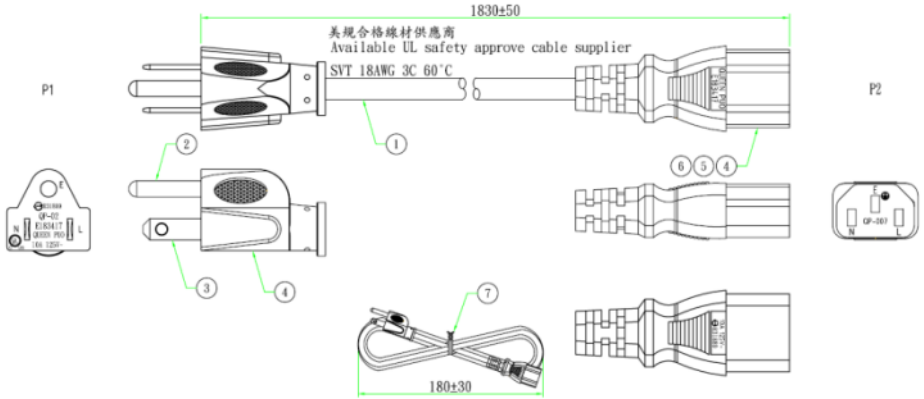

064APOWBRW-IPD (UK version)

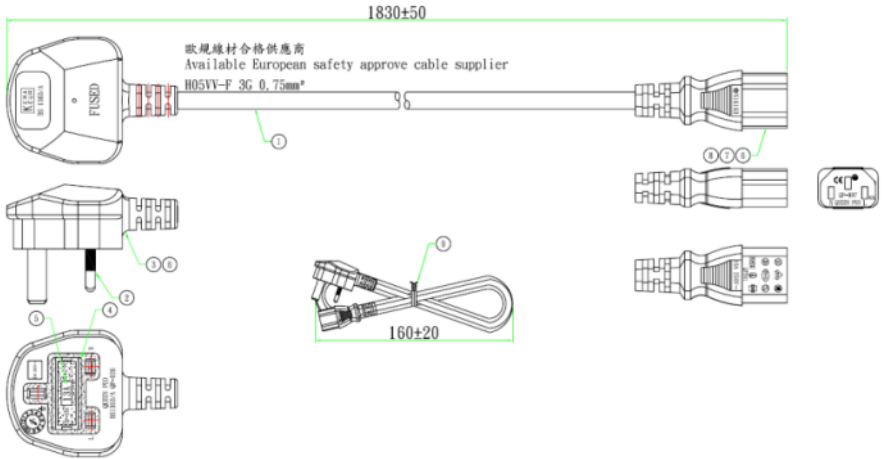

064APOWBR5-IPD (EU version)

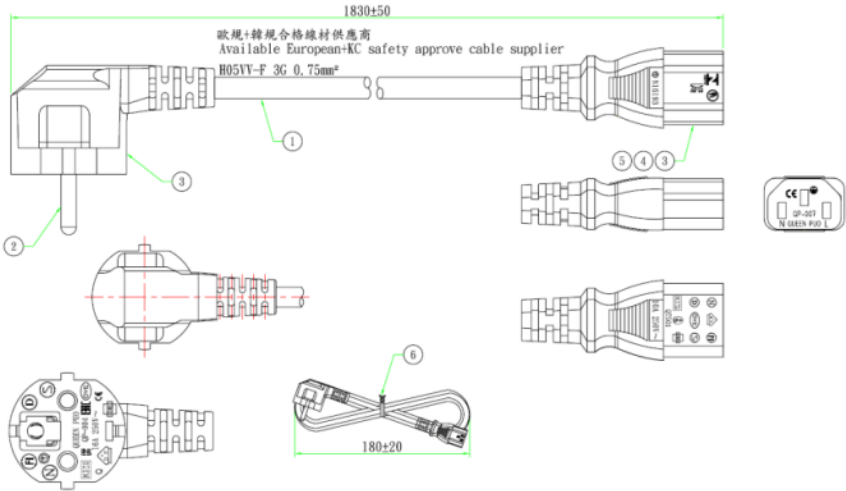

064APOWBRBSL (JP version)

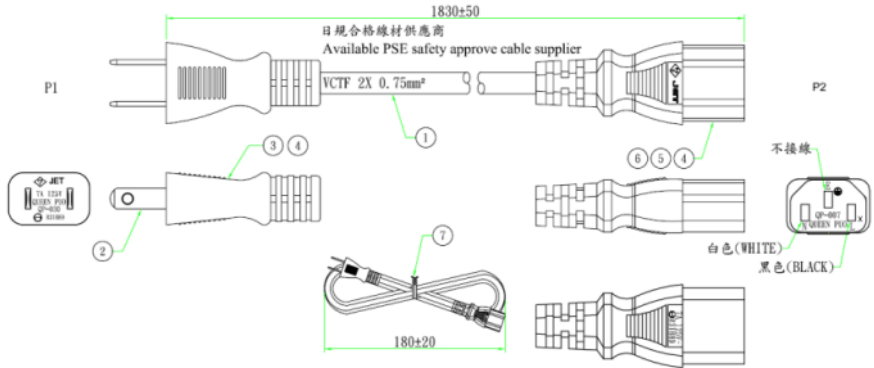

064APOWBR4-IPD (CN version)

