

WARNING:

Failure to follow the instructions from rsnav.com will result in repeating installation/removal of the device due to installation error. We understand it is in your DNA to not read instructions. At a minimum, please see following pages for the sake of all involved.

- No sound?
>See page 13 of the installation manual
- Static Factory interface? Wrong resolution in the factory interface? Factory MMI knobs and buttons not working? >
Page 1 of the user manual
- After above step the factory MMI Knobs and buttons are still not working? See page 10 of this manual

Frequently Asked Question or frequent mistakes

Q: Passenger Airbag Off warning indicator, Parking view button, and/or Start/Stop button, Spoiler Buttons are not working

A: You have forgotten put back those small plugs behind those buttons. Probe with your finger under the fascia of MMI CD Player.

Q: ACC/Breaking Guard Unavailable Appears.

A: Adaptive Cruise Control system requires many systems to be nominal. ACC/Breaking Guard warning will appear when S3,S4 system is rebooting while driving. It should be gone in next 10 seconds. If the warning persists then check followings.

- MMI console connector between S3,S4 screen and main harness is loose or disconnected.
- GPS Y adaptor/antenna is broken, or the line is damaged
- Passenger Airbag indicator is disconnected
- Parking brake button is not working.

Q: There are several errors in DTC code in relation to J794 5F MMI Media Unit

A: 00259, screen mechanism fault, intermittent signal errors, implausible signal are normal. 00259 and screen mechanism fault are telling that the original Audi screen is not present, and other errors are recorded when MMI console is being used by S3,S4 Android system.

There is no impact of there error codes on your existing factory warranty.

RSNAV.Com Android System 4G C7 Installation Manual

 **Warning: Professional installation recommended. Mask the working trim surface properly, otherwise, it will be scratched easily while installing!**

1. Installation Preparation

A. Dashboard Insert lower trim:

Move steering wheel down and to rear as far as possible, using full range of steering column adjuster.

Unclip trim cover -1- using removal wedge -3409--arrow- and remove.

Repeat procedure on opposite side of trim cover.

Remove bolts -1- and -3-.

Using a small flat screwdriver, carefully unclip trim cover -2- from trim (top) for steering column switch module -arrow A-.

Unclip trim cover for instrument cluster from dash panel -arrows B- using removal wedge -3409-.

Detach trim cover.

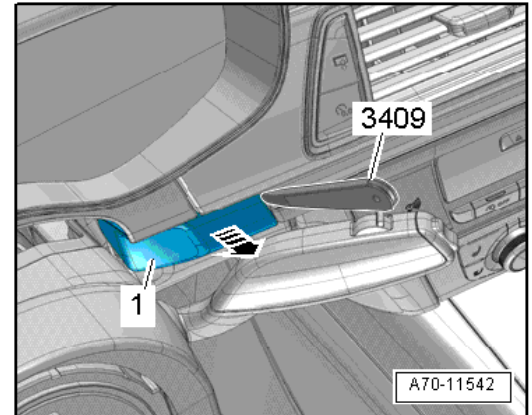

B. Cover (centre):

- Carefully unclip cover -1- for display unit using a wedge to arrows direction and detach.

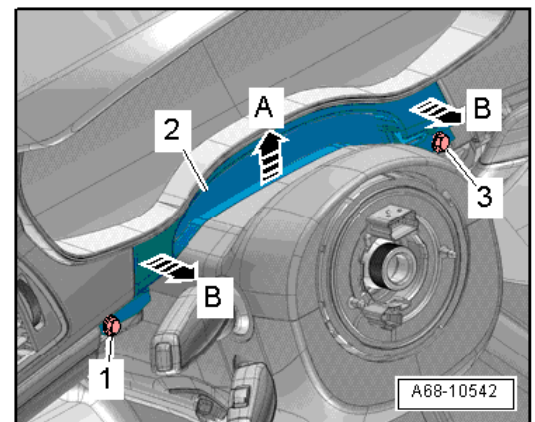
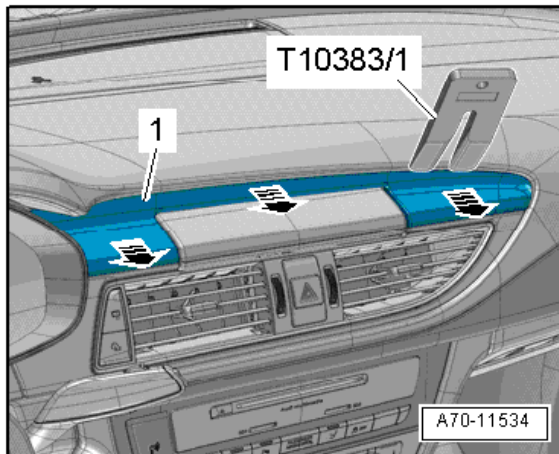

C. Dash panel vent(centre):

Remove bolts -1- and -3-.

Using wedge -T10383/1- prise dash panel vent -2- out of dash panel towards rear -arrows-.

Unplug electrical connectors and detach dash panel vent.

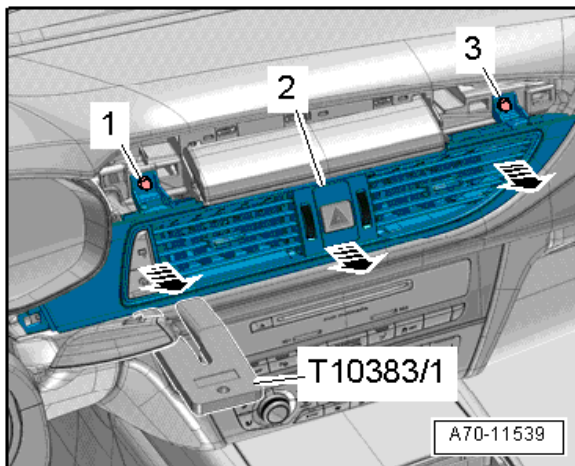

RSNAV.Com Android System 4G C7 Installation Manual

D. Removing the factory screen:

Remove bolts -2- and pull display unit for front information display and operating unit control unit -J685--1- out of dash panel until connectors on reverse side are accessible.

First disconnect wiring clip -4-, proceed with display connectors -1- and -3-, then wiring clip -2- and finally unplug connector for motor -5-.

Pull display unit for front information display and operating unit control unit -J685- completely out of dash panel.

*Centre Speaker is accessible behind where the factory screen was. If inaccessible you may want to remove the speaker as well.

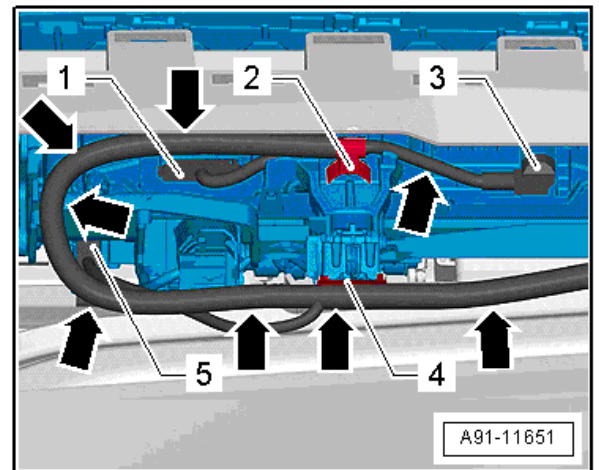
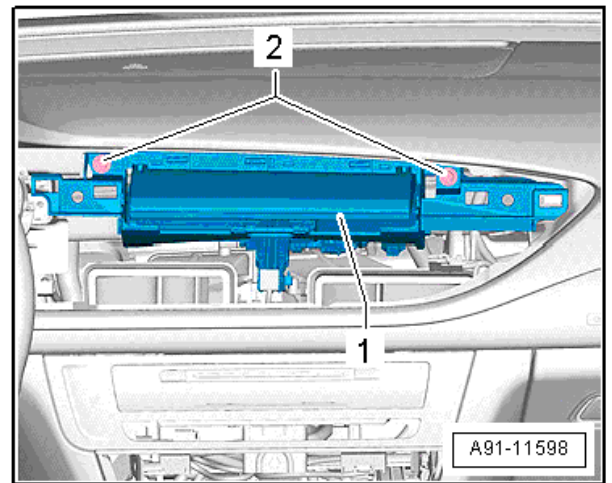

E. Removing Climate Control and MMI head unit:

Carefully pull the operating unit -1- with the hook -T40207- out of the guides on the left and right as far as the first detent. – Tilt the operating unit downwards slightly and disengage the retaining hook -2- at the dash panel. Unplug connectors by sliding locking elements and press-pulling the locks.

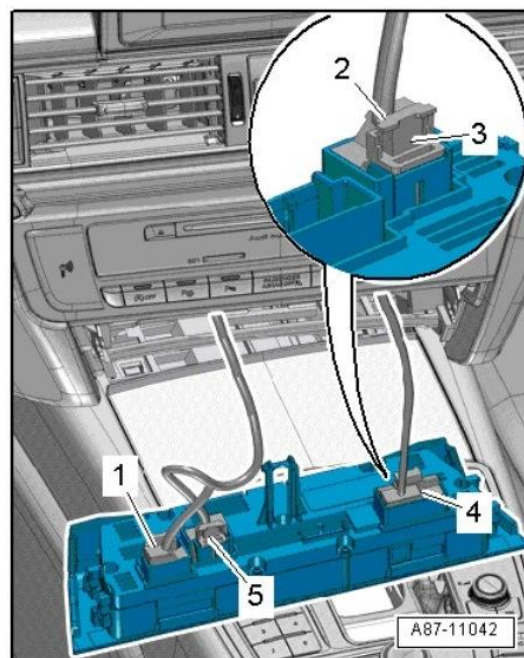
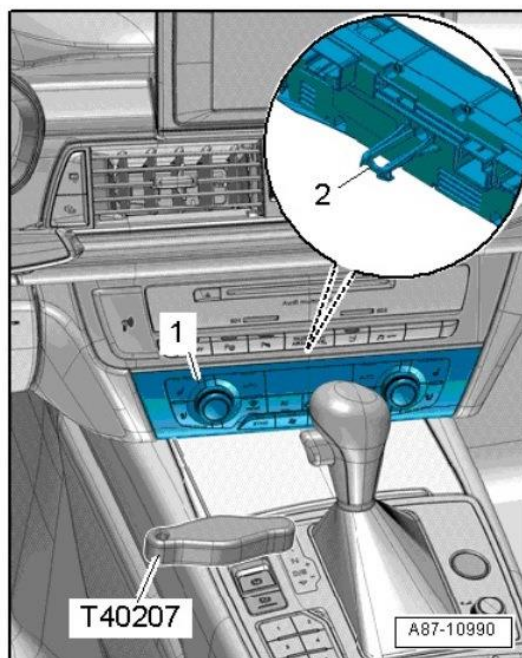

RSNAV.Com Android System 4G C7 Installation Manual

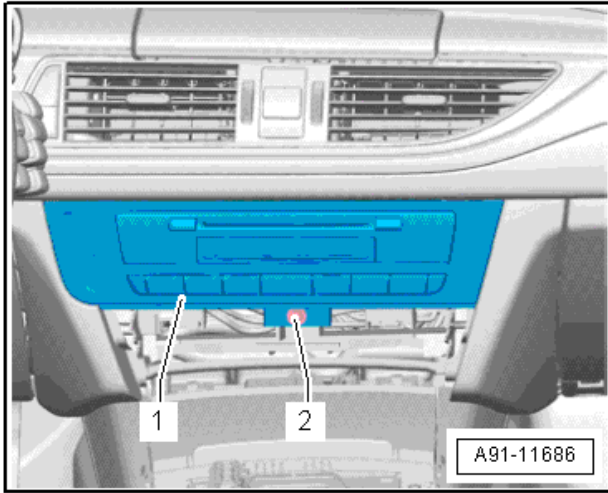

Remove bolt -2- on control unit 1 for the MMI unit -J794- -1-.
Pull control unit 1 for infotainment electronics -J794- -1- out of mounting frame.
Release and unplug necessary connectors at the back of the control unit

F. Removing centre loudspeaker trim (Do this if and only if necessary) :



Proceed very carefully when removing and installing loudspeaker trim, as retaining pins for loudspeaker trim can break off very easily. Make sure that you apply the removal wedge -3409- at a very shallow angle, otherwise you may inadvertently also prise out the centre defroster vent located under the loudspeaker trim.

Use a cloth -1- to protect dash panel from damage.

Using removal wedge -3409-, start by carefully disengaging loudspeaker trim -2- at rear right rounded edge -arrow-.

Working gradually from right to left -arrow-, continue to disengage loudspeaker trim; do not lift loudspeaker trim higher than -a- = 30 mm.

When loudspeaker trim is fully disengaged at rear, lift slightly, pull towards rear and remove upwards.

Then remove the centre loudspeaker by removing bolts -2-
Release and unplug connector at centre speaker -1-
Remove the centre loudspeaker from dash panel.

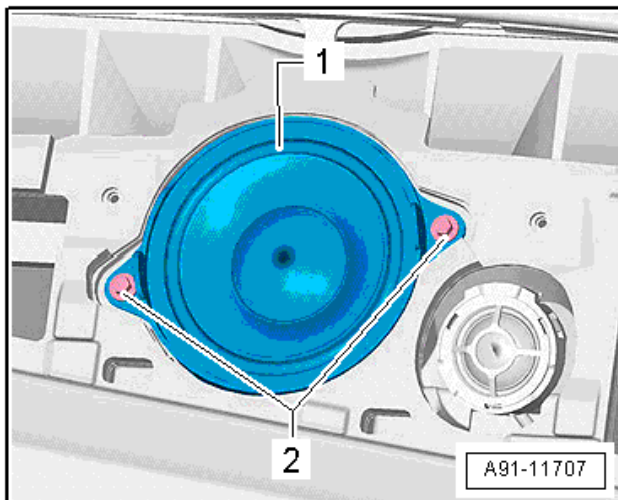
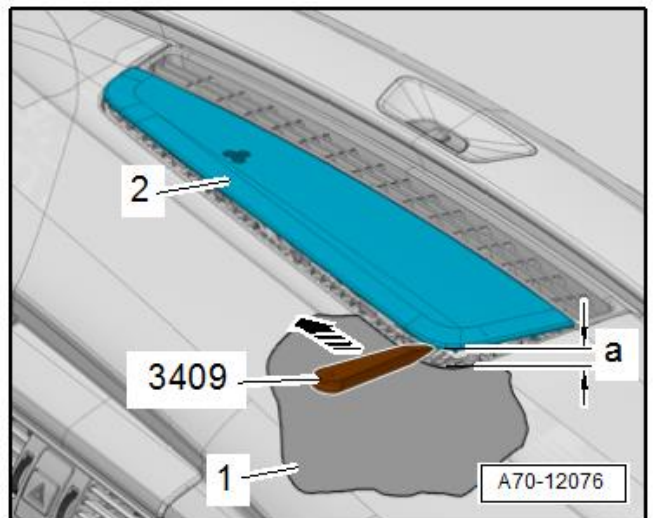
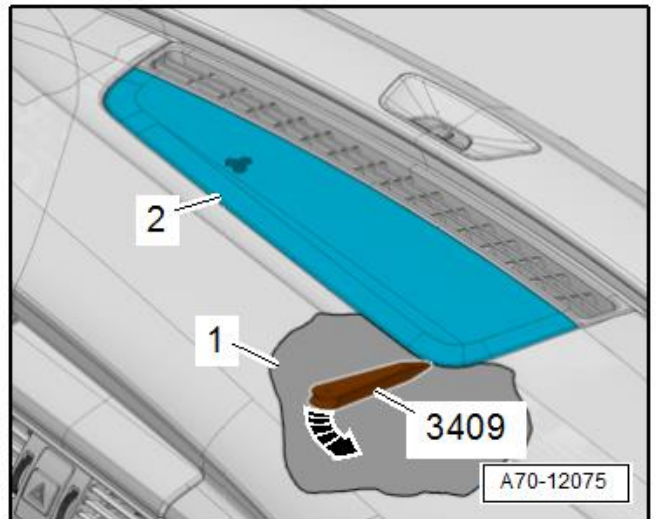

RSNAV.Com Android System 4G C7 Installation Manual

G. Removing dash panel cover (driver side)

Prise off dash panel cover (side) -1- using removal wedge -3409--arrow- and detach.

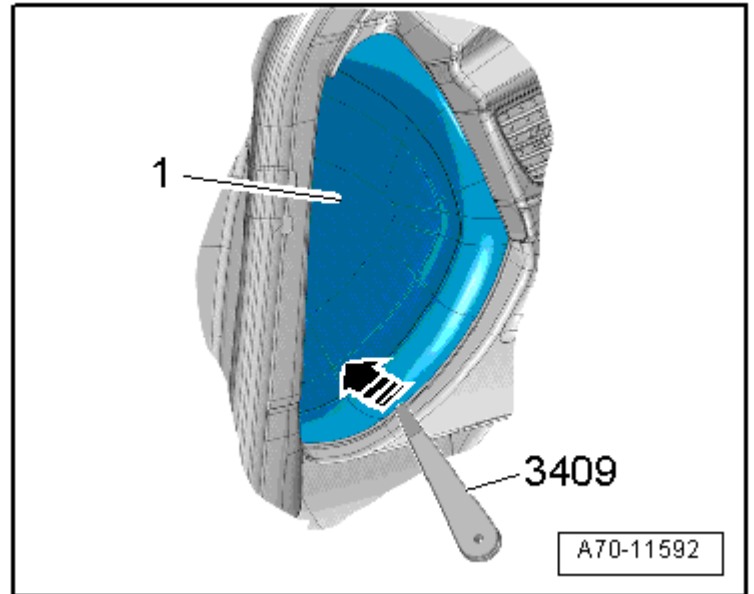

Remove bolt -1- at side.
Remove bolts -3- at bottom.

Unclip top edge of dash panel cover (driver side) -2- from dash panel -arrows- using wedge -T10383/1-.



Warning:

There may be a knee airbag installed for certain trim level. If that is the case, do not touch the airbag connector without anti-static band. To assure 100% safety you may want to disconnect battery while you are working near the airbag. If the airbag ignites it may cause serious injury.

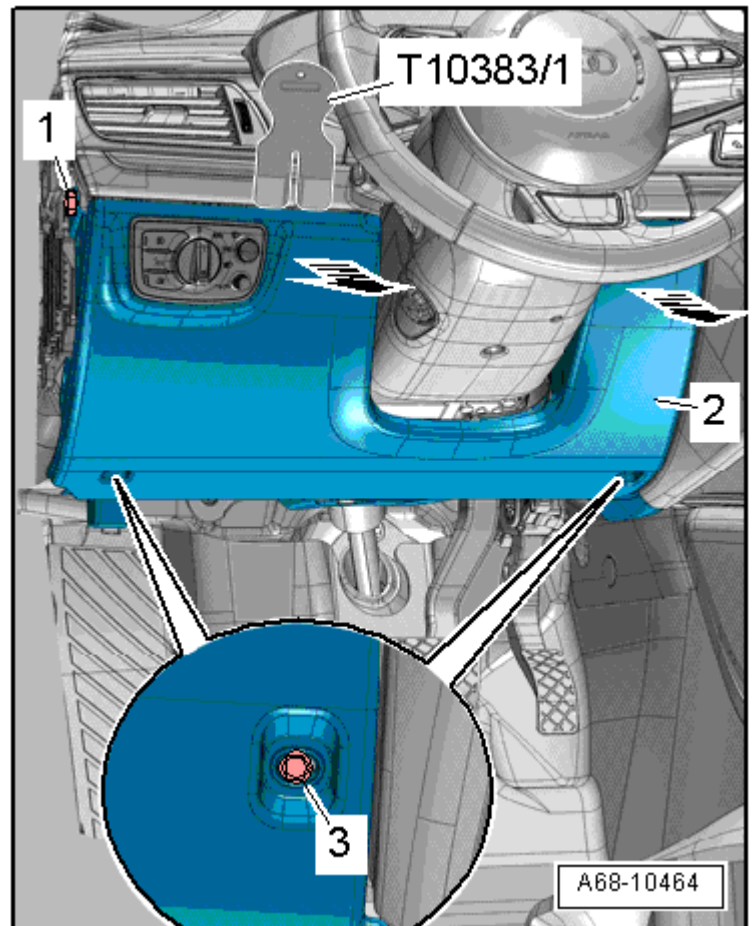



Please visit following website to see wiring diagram before proceeding

https://rsnavwiki.com/Help:Wiring_Diagram

RSNAV.Com Android System 4G C7 Installation Manual

3. Installation

A. General view after taking down driver's kick panel.



The Styrofoam to fill the void need to be removed to acquire some space. Pull it off with force and it will detach.

B. Remove MMI unit entirely and look for the space **behind the round hole** that you can take out your factory quad lock plug to the driver side kick panel area.



RSNAV.Com Android System 4G C7 Installation Manual



Take out your factory original quad lock plug to the left (right side of steering column). This is the most difficult part of the installation.  **Wear a thin glove before you work inside the dash frame. Otherwise you will injure your hand. It is NOT the round hole that you take out the big plug, but it is the vacant space behind the round hole.**



Plug RSNAV quad lock female into the factory male plug.

RSNAV.Com Android System 4G C7 Installation Manual

Route RSNAV quad lock male back to the cavity where the factory quad lock male plug was like in the circle below. Also route RSNAV white connector to the arrow direction.

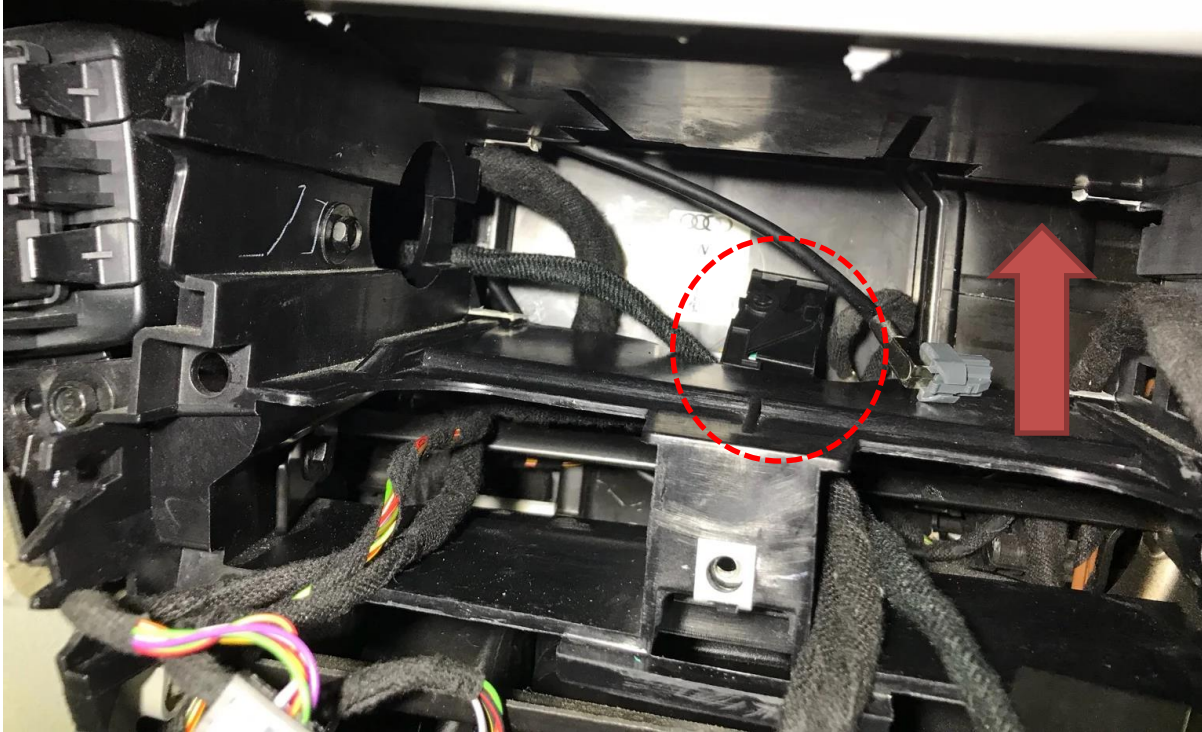

C. Route RSNAV white plug into upper air vent area through space **behind the air ducts**.



RSNAV.Com Android System 4G C7 Installation Manual

D. (3G MMI, RMC only) Plug the climate control bypass to the back of the climate control panel.



E. MMI Console Connection

Red 4wire male plug comes directly out of the screen, and two wire female plug is on the main wiring harness.



For 3G MMI devices
This connectors must
be manually
connected to make
sure MMI console to
work properly.

F. Installing Y-GPS bypass



- A: Connect to the back of MMI head unit (CD Player)
- B: Connect to the back of RSNAV Android device
- C: Connect to the car's GPS wire that is detached prior to the installation prep.

RSNAV.Com Android System 4G C7 Installation Manual

G. Installing Cellular antenna

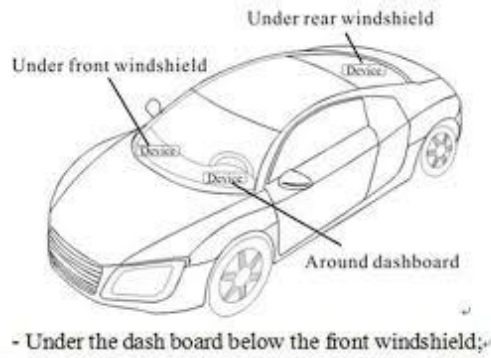
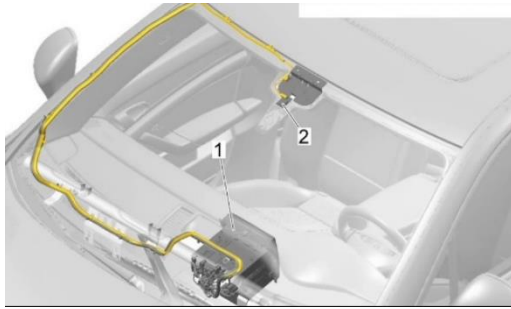

- Preferred location of cellular antenna is near the rear-view mirror. However, signal reception may vary as each vehicle has different rate of signal penetration.

Removing A-pillar trim to pass the antenna wires to windshield.



WARNING

There is a curtain airbag behind this trim, and it may ignite if not be careful.

- Switch on ignition.
With ignition switched on, disconnect battery earth wire.
- Before handling pyrotechnic components and restraint systems (e.g. unplugging electrical connector) the mechanic must discharge static electricity by briefly touching the door striker plate, or similar.



WARNING

Observe safety regulations for pyrotechnic components

- Use a screwdriver to carefully unclip cap -1- with "airbag" symbol from A-pillar trim (top).
- Starting at top, carefully unclip A-pillar trim (top) -3- with removal wedge -3409--arrow A-.
- Pull A-pillar trim (top) out of dash panel -arrow B- and detach.

Installing



WARNING

Observe safety regulations for pyrotechnic components

Take care not to trap curtain airbag when fitting A-pillar trim (top).

Installation is carried out in the reverse order; note the following:



Note

If there are still trim clips in the body mounting points, they must be removed and inserted in the trim when installing.

Check the clips for damage or deformation and renew them if necessary.

- Use a thread tap to remove any residual locking fluid from threaded hole for bolt for A-pillar trim (top).



Note

If the threaded hole is not cleaned, there is a danger of the new bolt seizing when being screwed in and then shearing off the next time you try to remove it.

- Insert A-pillar trim (top) -1- in mounting -2- of dash panel and sill panel trim (front) in direction of -arrow-.
- Clip in A-pillar trim (top) and fold over lip of door seal.

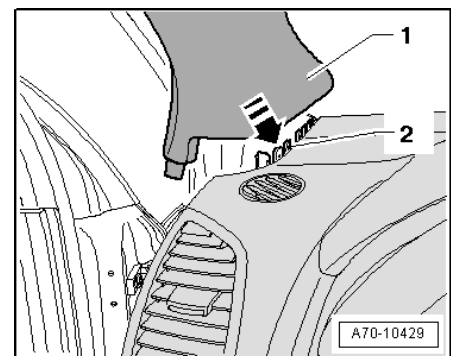
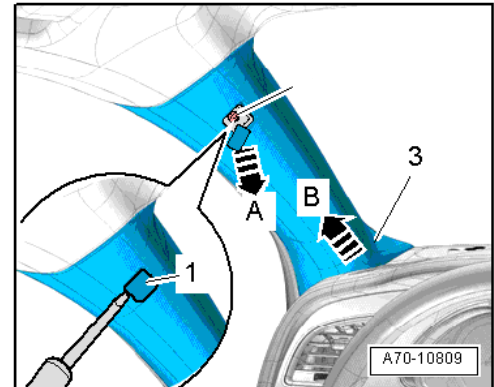

RSNAV.Com Android System 4G C7 Installation Manual



It is not necessary to remove A-pillar trim and or roof lining to pass wires. Pull down lining with a bit of force and squeeze in the antenna wires.

- H. Plug LVDS wire (Factory screen round 4 pin plug), GPS, 4G Antennas, and Main power connector and USB, SIM card extension wire.



- I. Mount RSNAV screen using the factory bolts **temporarily**. Do not screw down completely, but leave the device **hanging tight**. **Put back the air vent for fitment trial**. In order to fit the air vent with the new screen **properly**, you need to lift up **RSNAV screen slightly upward**, also there are guides on the plastics to help positioning the screen and vents. **Transfer clips from factory screen dash trims to supplied RSNAV dash cover** and try the fitment. If fitment is not good, unscrew the upper two bolts a bit, move the screen left or right and adjust it until everything fits well together. Once you find good position for all, screw down upper two first and reinstall centre air vent and screw the remaining two bolts.

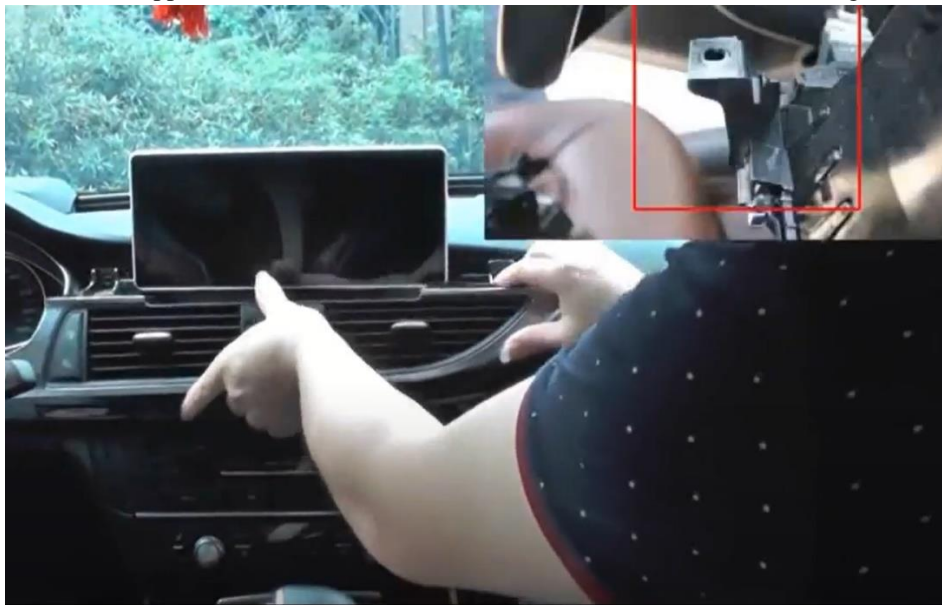

- J. Reassemble remaining parts in reverse order.

RSNAV.Com Android System 4G C7 Installation Manual

4. Activating External Audio Input

⚠ **If this is not done, there will be no sound from the device.**

⚠ **Audi AMI to Aux Adaptor is not a part of the installation kit. You need to purchase it separately from Audi dealer or web retailers like Amazon, eBay.**

⚠ **iPod 30pin, USB, Lightening Connector, Bluetooth dongle type AMI adaptors are **NOT** equivalent to the Audi AMI to AUX adaptor.**

Method 1.

If you have AMI to AUX adaptor, please plug it in to MMI/AMI plug to activate external audio source in Media tab of your MMI.



Plug this side to your AMI Port in centre armrest

Do not plug this side to anything

Method 2. 3G MMI only, Coding the system using Vag Com (or OBD Eleven)

Enabling Aux input in MMI

1. Preparation: Enable Green menu using VAGCOM or OBD Eleven
Connect with module 5F – Control Head.
Choose procedure 10 – Adaptation.
Choose Perquisite Channel 6.
Read stored value. By default it should be 0.
Change value to 1 and save it.
Read stored value. Now it should be 1.
Exit

<Next>

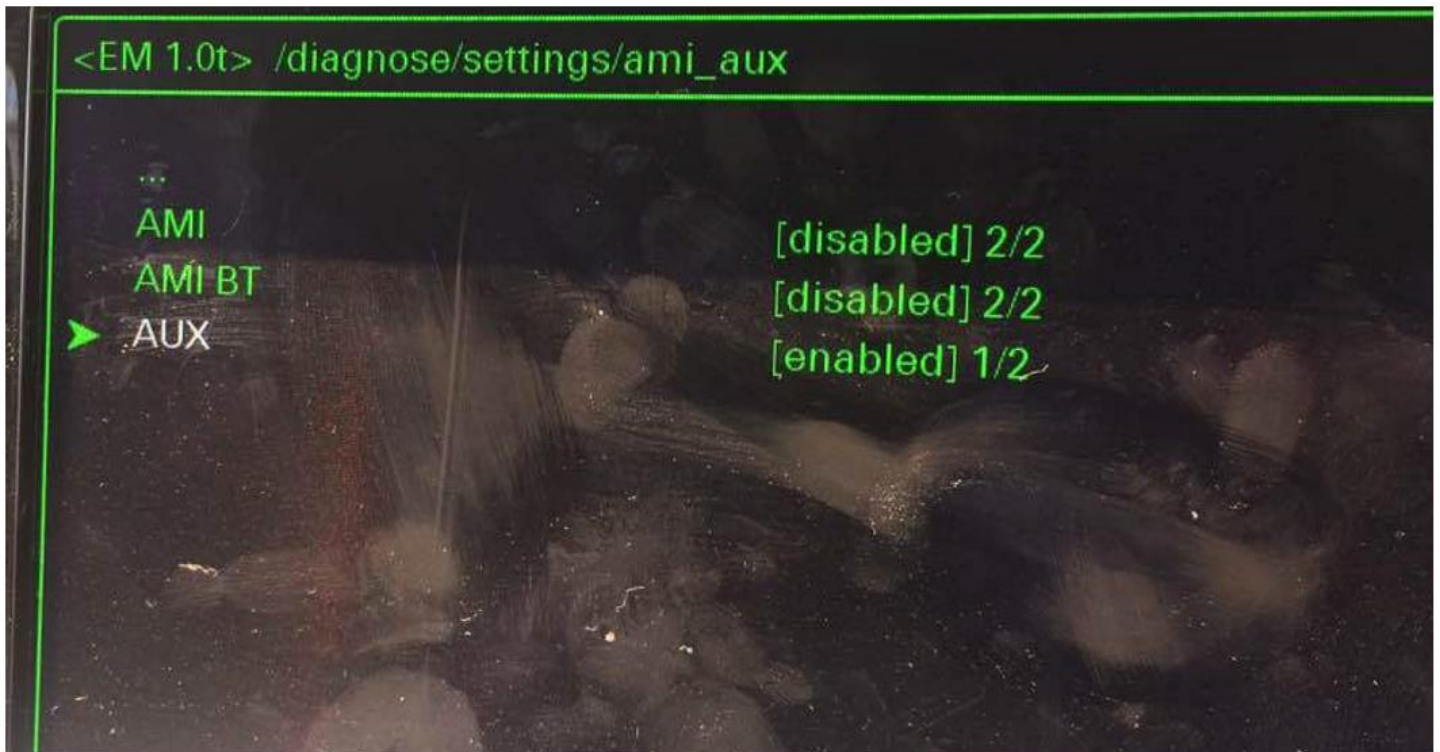

Audi MMI 3G AUX activation procedure

1. Turn key into II position and wait for the MMI 3G system to start. You can also use keyless button.
2. Press and hold buttons MENU(or SETUP) and CAR.
3. After couple of seconds hidden green menu will appear. You can now release the buttons.
4. Navigate to diagnose → settings → AMI/AUX.
5. Change the value of “AUX” “disabled” to “enabled” preserving other options.
6. Press RETURN and CAR buttons at the same time to exit hidden green menu.
7. Restart the MMI

Audi MMI force restart procedure – 3G+



Locate button:

- A. MENU(or SETUP) button
- B. MMI Center knob
- C. Upper-right soft button

Press and hold those buttons at the same time.

After two seconds release buttons. Audi MMI screen will go black for few seconds and system will reboot.

RSNAV.Com Android System 4G C7 Installation Manual

5. Important information



A: Reset hole. Poke with a straightened paper clip until you feel clicking. The button may be not aligned with the hole, so prove it carefully. **Click once for rebooting** and click fast three times to boot into recovery mode. (Warning: Recovery Menu could reset the device to the factory default or may cause unexpected failure. Do not access to it unless required.)

B: **THIS IS NOT TF CARD(SD MEMORY CARD) SLOT. NOT IN USE.**

The is **NO TF-CARD slot for S3,S4 4G, 8W(B9) Variants.** (this is reserved for dual sim)