

WARNING:

Failure to follow the instructions from RSNAV.com will result in repeating installation/removal of the device due to installation error. We understand it is in your DNA to not read instructions. At a minimum, please see following pages for the sake of all involved.

- Glovebox removal necessary?
>Page 2 of this manual
- No sound?
>Page 13 of the installation manual
- Noise after plugging an AMI to AUX adaptor?
>Page 13 of the installation manual for Concert/Symphony
- Static lines in the factory interface? Wrong resolution in the factory interface? Factory MMI knobs and buttons not working?
>Setup 'Car Model' as in the page 1 of the user manual
 - For the 3G MMI knobs and buttons, see page 10 this installation manual if not working properly even after above step.
 - Concert/Symphony knobs and buttons are not supported as of late 2020 and may be supported in future as adding hardware

Frequently Asked Question or Frequent mistakes

Q: Airbag warning indicator turned on in the instrument cluster and there is DTC code related to ABS module and parking brake module.

A: This will be illuminated if you powered the car while the factory or RSNAV supplied hazard button assembly is not connected to your car. You must clear this error with VCDS or OBD Eleven or any other VAG service tool that can reset VAG airbag error.

If this error recurs then it is possible that you have given wrong information about the hazard button when you are placing an order or we may have sent you a wrong type of hazard button PCB. Contact us.

Q: There are several errors in DTC code in relation to J794 5F MMI Media Unit

A: 00259, screen mechanism fault, intermittent signal errors, implausible signal are normal. 00259 and screen mechanism fault are telling that the original Audi screen is not present, and other errors are recorded when MMI console is being used by S3 Android system.

There is no impact of these error codes on your existing factory warranty.

Q: Two LED in the MMI console flash even after the car has been shutdown and locked.

This is normal. The flashing will be gone in next 10 minutes. It is telling that there is something not Audi original installed to the car.

Q: Is external Mic should be installed? (8.8" or RHD only)

Yes, this is required. Connect it to the 3.5mm audio plug coming out of the screen.

IT IS RECOMMENDED TO WATCH VIDEO INSTRUCTIONS FROM YOUTUBE BY SEARCHING WITH KEYWORD 'RSNAV'.

RSNav S3, S4 Installation Walk-through Guide

<https://youtu.be/6of9fhwb8zs>

by Daniel Polniak

You are invited to RSNAV user community for community help.

<https://www.facebook.com/groups/1101321910066525>

The user community is not associated with and maintained by RSNAV.com

For official support from RSNAV, visit <https://rsnav.com/pages/about-us>

RSNAV S3, S4 installation manual

For B8, B8.5 sedan or wagon

Tools required: **Car trim remover, 8mm Hex driver, T20 screw driver, cable ties, and Volkswagen radio removal keys.**

 Do read this manual thoroughly first as there are some situation that you must do or must not do.

 Switch off ignition and all electrical equipment before you begin the installation. Do not switch on the vehicle while any of original AUDI component is detached or disconnected.

For **Concert/Symphony radio**, It is **NOT required** to remove the glove box and install bypass connector to the CAN BUS gateway.



Removing and installing cover for MMI screen - up to model year 2011

Removing

- Use removal wedge to prise off cover -1- for MMI screen at corners -arrows- and detach.
- Unplug electrical connector for warning lamp for airbag deactivated on front passenger side / hazard warning lights button and detach cover.



Note

Check retaining clips for damage or deformation and renew if necessary.

- Press on cover for MMI screen until it engages audibly.

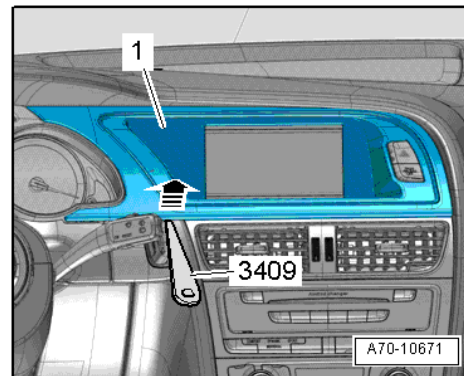

Removing and installing cover for MMI screen - from model year 2012 onwards

Removing

- Move steering wheel down and to rear as far as possible, using full range of steering column adjuster.
- Unclip cover -1- for MMI screen from dash panel at bottom -arrows- using wedge

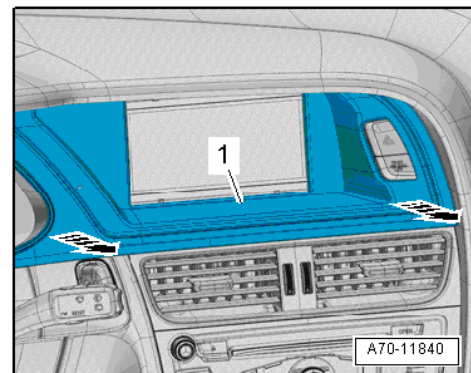

- Carefully unclip cover -1- for MMI screen from instrument cluster at bottom -arrow- using wedge

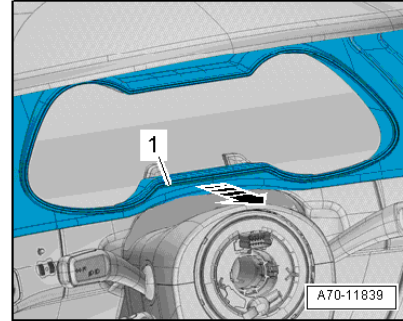

- Unclip cover -1- for MMI screen from dash panel at bottom -arrow B- using wedge.



Note

A hole is provided on both sides of the vent for engaging the hook.

- Carefully insert hook between louvres and engage at side of vent.
- Carefully disengage vent at sides -arrow A-.

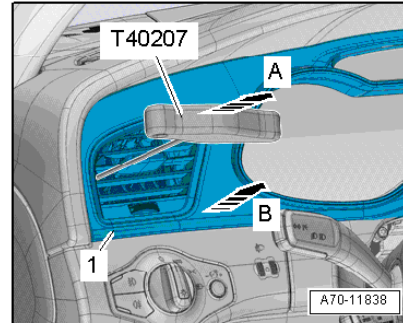

- Carefully unclip cover -1- for MMI screen from dash panel at top -arrows-.
- Unplug electrical connector at dash panel vent.
- Unplug electrical connector for warning lamp for airbag deactivated on front passenger side / hazard warning lights button and detach cover for MMI screen.

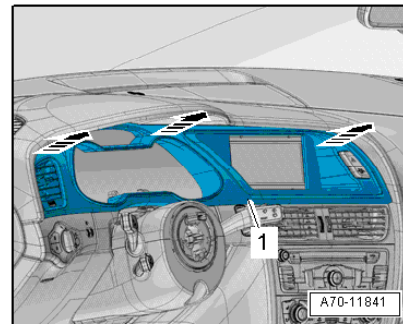

Removing and installing cover for MMI screen Q5



1. Pry out the screen fascia trim.



2. Unplug the emergency hazard button connector and remove the screen fascia. Also remove the factory original screen unscrewing 4 T20 screws.

Removing infotainment system display

Display unit for front information display and operating unit control unit (display) is located in dash panel (centre).

Removing

- Remove bolts -arrows- at display unit for front information display and operating unit control unit -1-.
- Lift display unit for front information display and operating unit control unit -1- out of dash panel -2-.
- Release and unplug connectors on display unit for front information display and operating unit control unit.

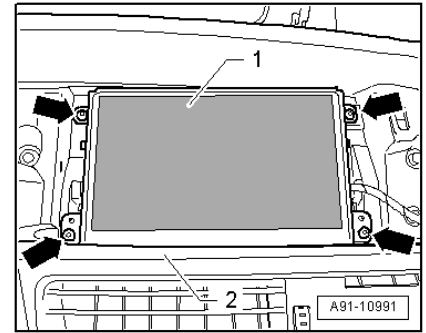

Removing dash panel vent (centre)

Removing



Note

A hole is provided on both sides of dash panel vent for engaging hook.

- Working alternately on each side, carefully pull dash panel vent -1- out of opening using hook.
- Equipment version with light: Unplug electrical connector at dash panel vent.



Note

Check retaining clips for damage or deformation and renew if necessary.

- When inserting dash panel vent in opening, make sure that air duct engages properly.
- Press dash panel vent into installation opening as far as stop.

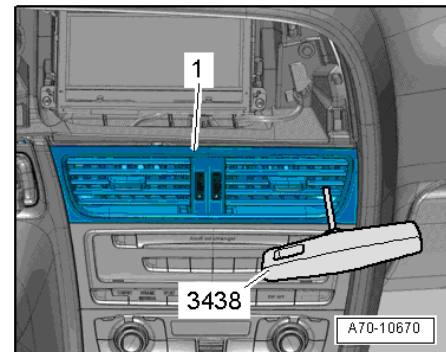

Removing climatization control unit for Concert/Symphony Radio

- Position hook -A- as shown in one of the openings -B- or -C- of air conditioner operating and display unit (Climatronic control unit).

- Carefully pull air conditioner operating and display unit (Climatronic control unit) out of centre console in direction of -arrow-.

Alternatively you can pry it out using wedge tool by squeezing the wedge into sides of the climatronic

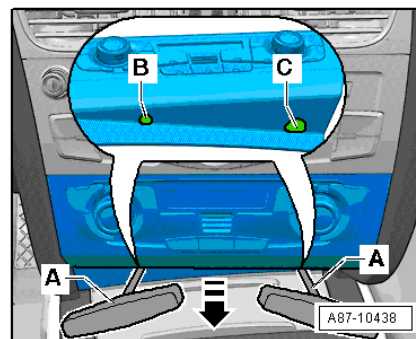

control unit, but if you hurry to bring it out, you may break the support brackets.



Note

The air conditioner operating and display unit (Climatronic control unit) is held in position by the clips (left and right) in the centre console support brackets. Unplugging connectors from air conditioner operating and display unit (Climatronic control unit)



Removing Concert/Symphony radio

Shift selector lever to “S” position (automatic gearbox) or move gear lever all the way to the rear (manual gearbox).

- (If the gear knob interferes while removing, turn keys into ignition mode without pressing brake pedal and then press the pedal, switches gear knob to Drive, turn off the key)
- Switch off ignition and all electrical equipment and remove ignition key.

Removing

- Remove bolts -arrows- at radio -R--1-.
- Pull radio -R--1- out of dash panel.
- Release and unplug connectors at radio -R-.

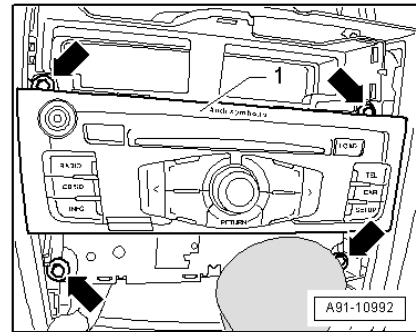
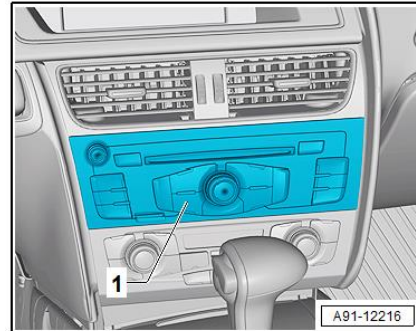

Removing and installing 3G MMI unit



Insert two VW, Audi radio removal keys for 3G MMI into release slots on control unit 1 for information electronics until they engage. Pointed ends of tool grips must face outwards.

- Pull control unit 1 for information electronics out of mounting frame.
- Press release tabs on control unit 1 for information electronics and remove VW, Audi radio removal keys.
- Release and unplug connectors at control unit 1 for information electronics.

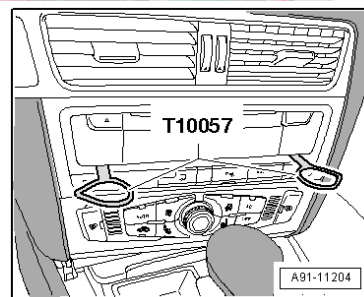

Removing for AMI (If you have one in your glove box)

- Insert two VW, Audi radio removal keys into slots on connection for external audio sources until they engage. Pointed ends of grips must face outwards.
- Pull connection for external audio sources out of mounting frame.
- Release and unplug all connectors at connection for external audio sources.

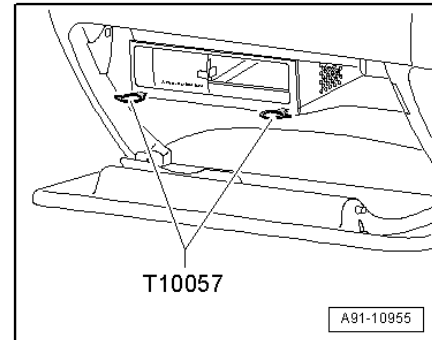

Removing and installing glove box

Removing

- Equipment version with storage box in glove box: Release retaining hooks (left and right) using a screwdriver -arrow- and pull storage box out of glove box.
- Equipment or country-specific version: Remove bolt -1- (top, side).
- Country-specific version with impact damper: Remove bolt -2-.

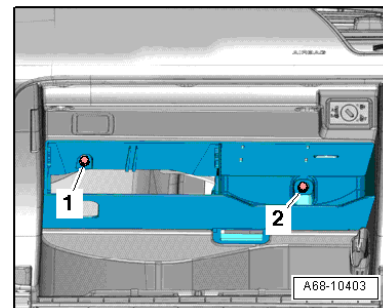
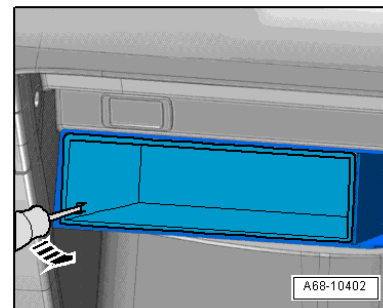

- Remove side dash panel cover (passenger side)
- Open glove box lid and unscrew bolts -arrows-.



Note

- The number of bolts depends on the country-specific version.
- Detach glove box and pull it out far enough so that you can unplug electrical connector at main connector.
-



Open the passenger side dash side cover using a trim removal tool. Unscrew the side bolt.

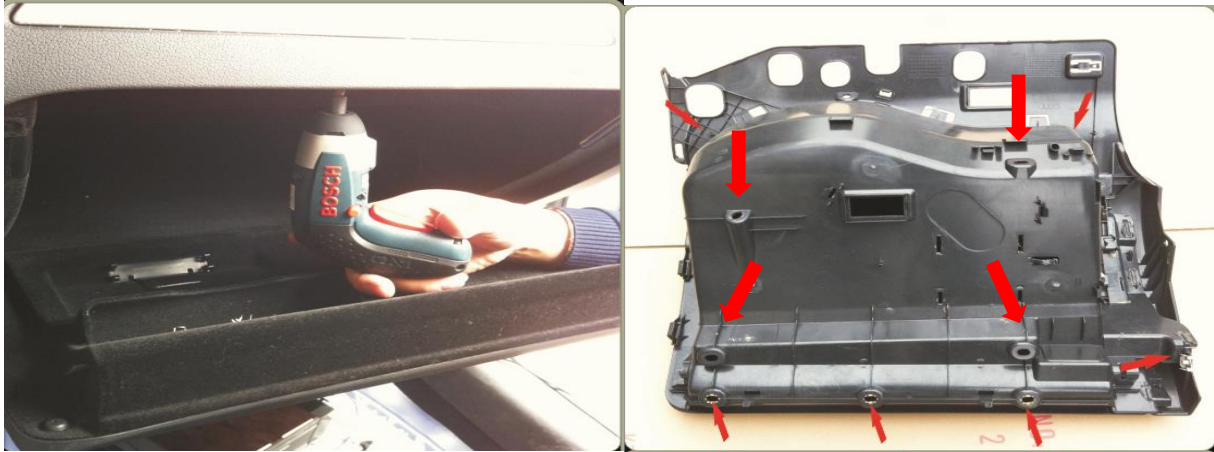

Passing main cable to screen compartment

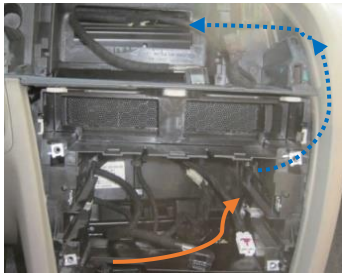

- Start to pass the main cable through the openings in the back of radio/head unit compartment holding 'white main male plug of the cable'. You need to pass the cable with both arms working in both radio compartment hole and the side hole of the glove compartment.



Please visit following website to see wiring diagram before proceeding

https://rsnavwiki.com/Help:Wiring_Diagram

For Concert/Symphony Radio unit installation only



Remove the climate control panel, unplug the far right large connector, and install the T-bypass supplied with the kit. It is not required to remove the glove box and install bypass connector to the CAN BUS gateway.

For 3G MMI unit installation only



- Locate CANBUS gateway near the glove compartment and install the bypass line. **The car must be turned off when disconnecting and connecting plugs into the CANBUS gateway. Also, do not press start button or key into ignition while CANBUS gateway wiring is disconnected. This will cause many electrical problems and error codes.**
- Make sure every pin is well connected without any pin escape or bent. This is the most critical electronic component for your car and many problems will arise if you don't connect it properly.
- If you have error code with a particular system (e.g. parking break, lane assist) or the car does not start, inspect the CANBUS gateway bypass cable and pins thoroughly. In some cases, male pin on our CANBUS gateway receptacle may be bent or escaped if there was excessive force to plug the connector.

Any cable route must avoid the CAN BUS in any cost. Otherwise, you will have weak WIFI signal, abnormal WIFI downlink speed, noise from speakers and abnormalities.

The Green is the proper route, and the red is the common mistake and bad route.



Join all the connectors properly. Make sure all the connection is tight and well connected. For the quad lock plug there is a lever to release/lock plugs each other also there is latches inside the female plug to make sure tight connection. The female quad lock plug completely covers the male quad lock plug and there must be no escape of the male quad lock.

For 3G MMI Console, following plugs must be joined ma

Red 4wire male plug comes directly out of the screen, and two wire female plug is on the main wiring harness.

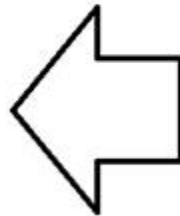

For 3G MMI devices
This connectors must
be manually
connected to make
sure MMI console to
work properly.

Installing Centre Speaker Bypass and routing USB Cable port



Remove the center dash speaker trim using a trim removal wedge, and unscrew the center speaker holding screws. Install the speaker bypass stemming from the main harness.



Route USB port into the glove box compartment by opening a hole using a drill or let out the USB port on the passenger side left side foot wall by probing into trim gaps.

Installing GPS and Cellular antennas

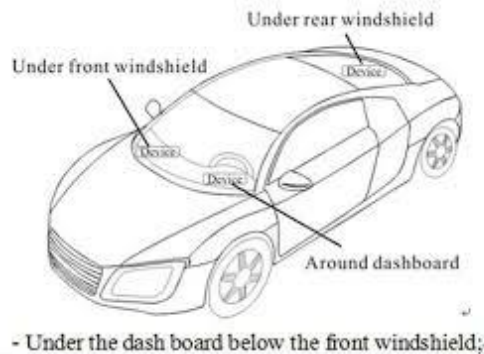
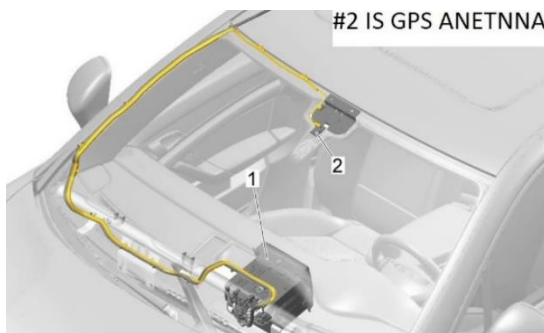

- Preferred location of both antenna is near the rear-view mirror. However, signal reception may vary as each vehicle has different rate of signal penetration.
- Using GPS test plus app as well as mobile signal checking tools available from Google Play Store to determine the best location and angle of the antennas.

Removing A-pillar trim to pass the antenna wires to windshield.



WARNING

There is a curtain airbag behind this trim, and it may ignite if not be careful.

- Switch on ignition.
With ignition switched on, disconnect battery earth wire.
- Before handling pyrotechnic components and restraint systems (e.g. unplugging electrical connector) the mechanic must discharge static electricity by briefly touching the door striker plate, or similar.



WARNING

Observe safety regulations for pyrotechnic components

- Use a screwdriver to carefully unclip cap -1- with "airbag" symbol from A-pillar trim (top).
- Remove bolt -2-.
- Starting at top, carefully unclip A-pillar trim (top) -3- with removal wedge -3409--arrow A-.
- Pull A-pillar trim (top) out of dash panel -arrow B- and detach.

Installing



WARNING

Observe safety regulations for pyrotechnic components

Take care not to trap curtain airbag when fitting A-pillar trim (top).

Installation is carried out in the reverse order; note the following:



Note

If there are still trim clips in the body mounting points, they must be removed and inserted in the trim when installing. Check the clips for damage or deformation and renew them if necessary.

- Use a thread tap to remove any residual locking fluid from threaded hole for bolt for A-pillar trim (top).



Note

If the threaded hole is not cleaned, there is a danger of the new bolt seizing when being screwed in and then shearing off the next time you try to remove it.

- Insert A-pillar trim (top) -1- in mounting -2- of dash panel and sill panel trim (front) in direction of -arrow-.
- Clip in A-pillar trim (top) and fold over lip of door seal.

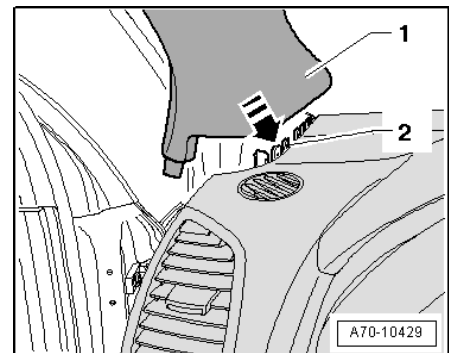
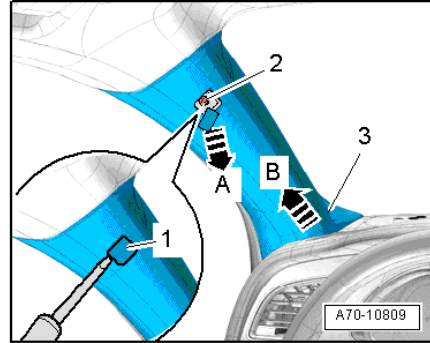

It is not necessary to remove roof lining to pass a wire. Pull down lining by a bit of force and squeeze in the antenna wires.

Getting Sound from the unit

If this is not done, there will be no sound from the device.

Audi AMI to Aux Adaptor is not a part of the installation kit. You need to purchase it separately from Audi dealer or web retailers like Amazon, eBay.

iPod 30pin, USB, Lightning Connector, Bluetooth dongle type AMI adaptors are **NOT** equivalent to the Audi AMI to AUX adaptor.

Concert/Symphony



Plug square connector side to your AMI in glovebox

Plug audio connector to the aux output port on the main harness of RSNV device

3G MMI/MMI+

Method 1.

If you have AMI to AUX adaptor, please plug it in to MMI/AMI plug to activate external audio source in Media tab of your MMI.

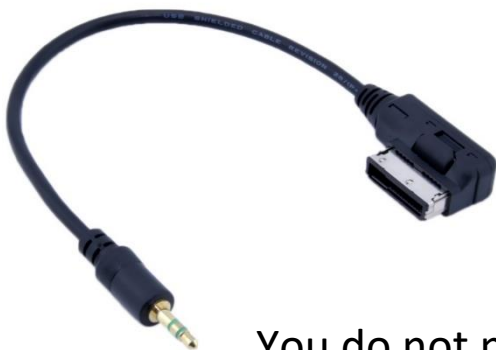

Plug this side to your AMI in glovebox

You do not need to connect audio side to anywhere

Method 2. Coding the system using Vag Com (or OBD Eleven)

Enabling Aux input in MMI

1. Preparation: Enable Green menu using VAGCOM or OBD Eleven
Connect with module 5F – Control Head.
Choose procedure 10 – Adaptation.
Choose Prerequisite Channel 6.
Read stored value. By default it should be 0.
Change value to 1 and save it.
Read stored value. Now it should be 1.
Exit

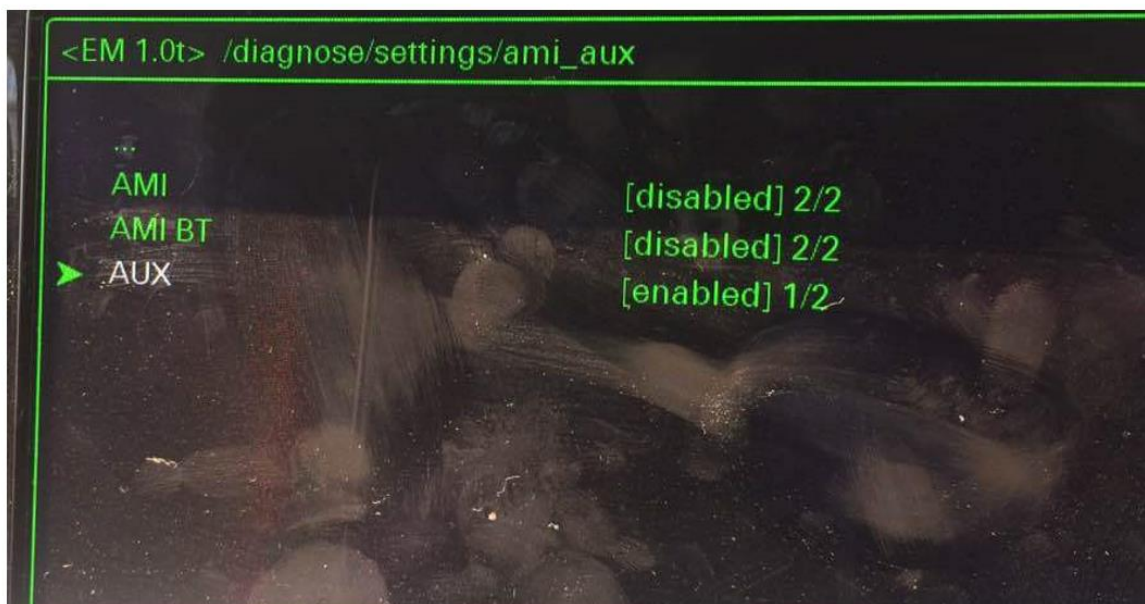

Audi MMI 3G AUX activation procedure

1. Turn key into II position and wait for the MMI 3G system to start. You can also use keyless button.
2. Press and hold buttons MENU(or SETUP) and CAR.
3. After couple of seconds hidden green menu will appear. You can now release the buttons.
4. Navigate to diagnose → settings → AMI/AUX.
5. Change the value of “AUX” “disabled” to “enabled” preserving other options.
6. Press RETURN and CAR buttons at the same time to exit hidden green menu.
7. Restart the MMI

Specific device related Installation tips and tricks

8.8-inch mounting instruction for Sedan



Install the metal plate to the position of original LCD screen. **Mind that the screw tabs have wide holes for the installer to mount new screen in an exact position. Do not screw tight before you confirm the fitment of LCD screen with the provided housing. If necessary, make the screw tabs trimmed down and screw holes wider so that you can mount it further left.** If the position is right, then screw the main device to two upper screw taps.



Connect new hazard flasher using provided hazard flasher extension.



Reuse every metal clip and rubber O ring, rubber stopper from the original LCD trim.



PCB with BL is for Pass. Airbag Off indicator equipped vehicle (e.g. the US)



For 8.8" 3G MMI model there are single wire plugs tabbed with label saying 09-12 or 13-15, choose right one for your car model (Preface lift or facelift). This one is for automatic aux switching.

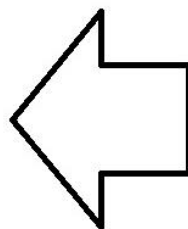

For 3G MMI devices This connectors must be manually connected to make sure MMI console to work properly.

10.25, 12.3-inch mounting instruction

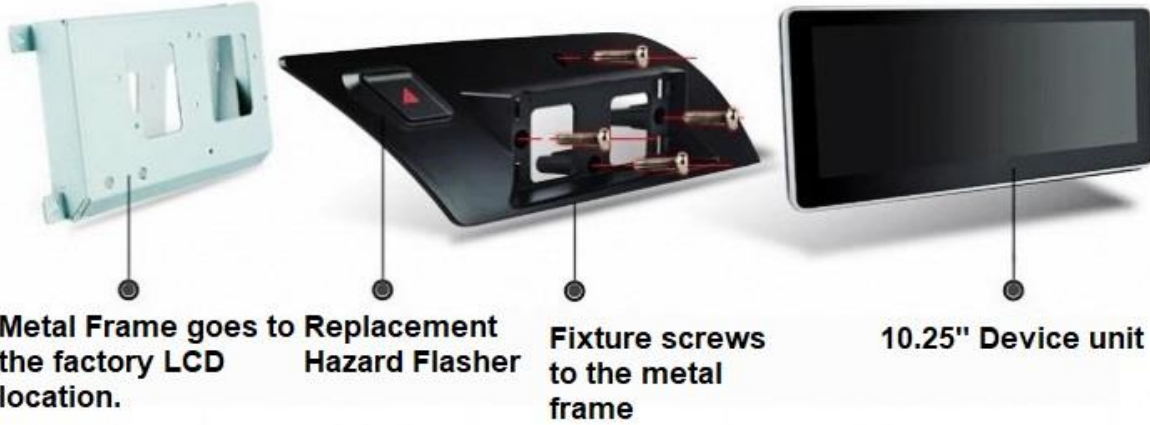

(optional) If you want secure installation of the mount, using a cutting tool, empty out the LCD fascia of the original LCD frame and remove the original hazard flasher. You can skip this process and partially screw down to preserve OEM plastic, but not recommended.



- Install the metal plate to the position of original LCD screen. Mind that the screw taps in four edges have wide holes for the installer to mount new screen the exact position. Do not screw tight before you confirm the fitment of LCD screen with the provided housing.

- If the position is right, then screw down plastic supporting frame with four screws.

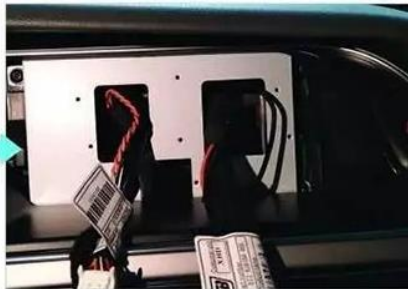

- Pass the wires through two holes. Identify what wire should pass which hole.



- Connect new hazard flasher using provided hazard flasher extension.



Mount the head unit by sliding into guide rails and open the screw covers in the back side of the main head unit (tablet) (screw down two large screws to fasten the tablet permanently for 10.25" device).

For 10.25" unit, there are four connectors.

1. 28 pin white main plug for various wires including power
2. Gold plated antenna connector for mobile modem
3. Gold plated antenna connector for GPS
4. Audi original display signal (LVDS) input port.

For LVDS input port, there is a conversion extension included in the package depending on your original infotainment type.



In some model, e.g. 10.25", the connection is made through included conversion extension.

or



For 3G MMI, 8pin black connector (power supply) is no longer used.

insert in right direction.

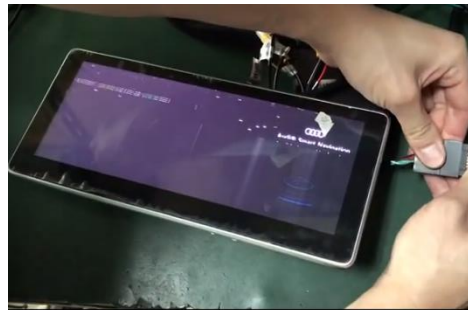

For 10pin LVDS cable, if original Audi screen scrambles like the picture, then you connected the original 10 pin male plug upside down. Verify the plug direction and

Clearing 'External Audio Source Active' message in instrument cluster

When you are using the steering wheel left roller button on Android, your instrument cluster would keep show 'External Audio Source Active' message. To clear this message and bring back the speedometer, use the Reset button on the bottom of the right Multifunction wiper control switch stalk instead of any other button in the steering wheel.



- End -