



# RSNAV S2 installation manual

For B8, B8.5 sedan or wagon

Tools required: **Car trim remover, 8mm Hex driver, T20 screw driver, cable ties, and Volkswagen radio removal keys.**

 Do read this manual thoroughly first as there are some situation that you must do or must not do.

 Switch off ignition and all electrical equipment before you begin the installation. Do not switch on the vehicle while any of original AUDI component is detached or disconnected.

**For Concert radio, It is not required to remove the glove box and install bypass connector to the CAN BUS gateway.**



## Removing and installing cover for MMI screen - up to model year 2011

Removing

- Use removal wedge to prise off cover -1- for MMI screen at corners -arrows- and detach.
- Unplug electrical connector for warning lamp for airbag deactivated on front passenger side / hazard warning lights button and detach cover.



Note

Check retaining clips for damage or deformation and renew if necessary.

- Press on cover for MMI screen until it engages audibly.

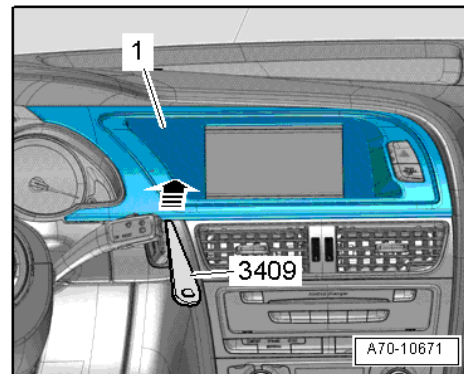

## Removing and installing cover for MMI screen - from model year 2012 onwards

Removing

- Move steering wheel down and to rear as far as possible, using full range of steering column adjuster.
- Unclip cover -1- for MMI screen from dash panel at bottom -arrows- using wedge

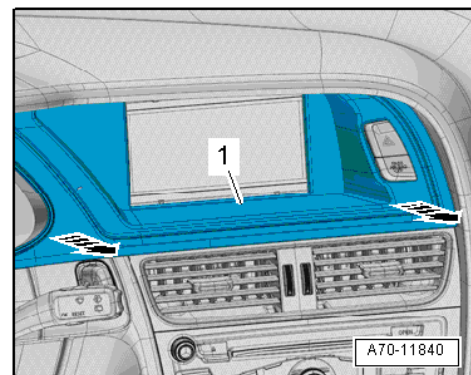

- Carefully unclip cover -1- for MMI screen from instrument cluster at bottom -arrow- using wedge

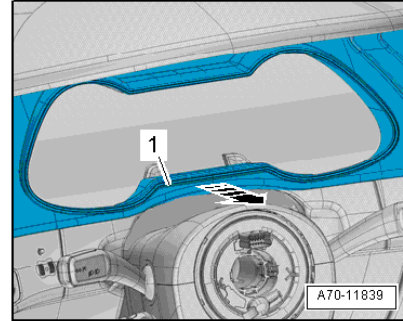

- Unclip cover -1- for MMI screen from dash panel at bottom -arrow B- using wedge.



**Note**

A hole is provided on both sides of the vent for engaging the hook.

- Carefully insert hook between louvres and engage at side of vent.
- Carefully disengage vent at sides -arrow A-.

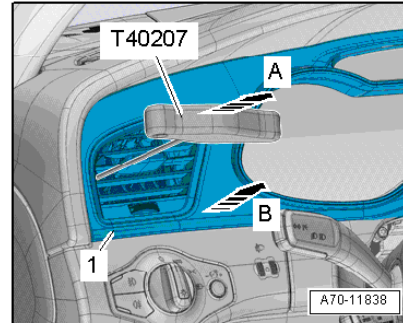

- Carefully unclip cover -1- for MMI screen from dash panel at top -arrows-.
- Unplug electrical connector at dash panel vent.
- Unplug electrical connector for warning lamp for airbag deactivated on front passenger side / hazard warning lights button and detach cover for MMI screen.

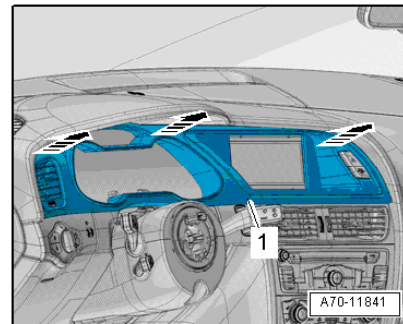

## Removing and installing cover for MMI screen Q5



1. Pry out the screen fascia trim.



2. Unplug the emergency hazard button connector and remove the screen fascia. Also remove the factory original screen unscrewing 4 T20 screws.

## Removing infotainment system display

Display unit for front information display and operating unit control unit (display) is located in dash panel (centre).

Removing

- Remove bolts -arrows- at display unit for front information display and operating unit control unit -1-.
- Lift display unit for front information display and operating unit control unit -1- out of dash panel -2-.
- Release and unplug connectors on display unit for front information display and operating unit control unit.

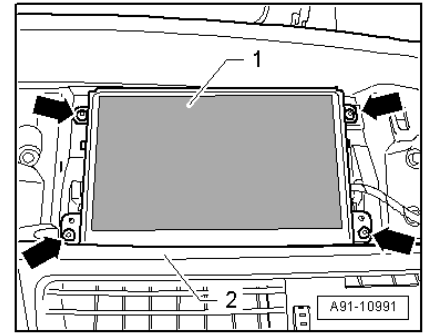

## Removing dash panel vent (centre)

Removing



Note

A hole is provided on both sides of dash panel vent for engaging hook.

- Working alternately on each side, carefully pull dash panel vent -1- out of opening using hook.
- Equipment version with light: Unplug electrical connector at dash panel vent.



Note

Check retaining clips for damage or deformation and renew if necessary.

- When inserting dash panel vent in opening, make sure that air duct engages properly.
- Press dash panel vent into installation opening as far as stop.

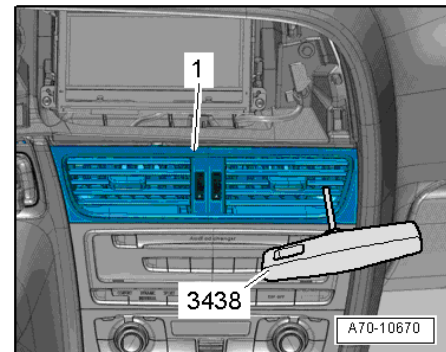

## Removing climatization control unit for Concert/Symphony Radio

- Position hook -A- as shown in one of the openings -B- or -C- of air conditioner operating and display unit (Climatronic control unit).

- Carefully pull air conditioner operating and display unit (Climatronic control unit) out of centre console in direction of -arrow-.

Alternatively you can pry it out using wedge tool by squeezing the wedge into sides of the climatronic

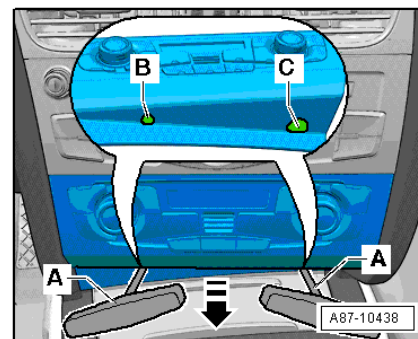



control unit, but if you hurry to bring it out, you may break the support brackets.



**Note**

The air conditioner operating and display unit (Climatronic control unit) is held in position by the clips (left and right) in the centre console support brackets. Unplugging connectors from air conditioner operating and display unit (Climatronic control unit )



**Removing Concert/Symphony radio**

Shift selector lever to “S” position (automatic gearbox) or move gear lever all the way to the rear (manual gearbox).

- (If the gear knob interferes while removing, turn keys into ignition mode without pressing brake pedal and then press the pedal, switches gear knob to Drive, turn off the key)
- Switch off ignition and all electrical equipment and remove ignition key.

**Removing**

- Remove bolts -arrows- at radio -R--1-.
- Pull radio -R--1- out of dash panel.
- Release and unplug connectors at radio -R-.

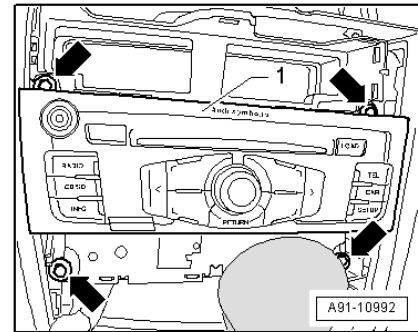
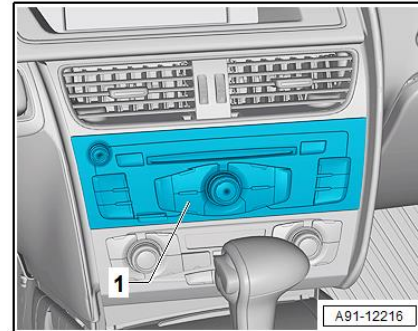

**Removing and installing 3G MMI unit**



Insert two VW, Audi radio removal keys for 3G MMI into release slots on control unit 1 for information electronics until they engage. Pointed ends of tool grips must face outwards.

- Pull control unit 1 for information electronics out of mounting frame.
- Press release tabs on control unit 1 for information electronics and remove VW, Audi radio removal keys.
- Release and unplug connectors at control unit 1 for information electronics.

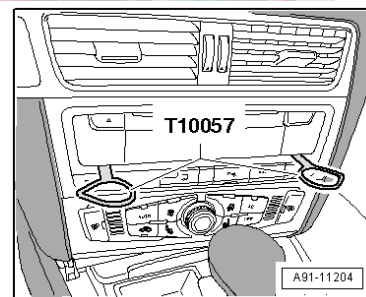

## Removing for AMI (If you have one in your glove box)

- Insert two VW, Audi radio removal keys into slots on connection for external audio sources until they engage. Pointed ends of grips must face outwards.
- Pull connection for external audio sources out of mounting frame.
- Release and unplug all connectors at connection for external audio sources.

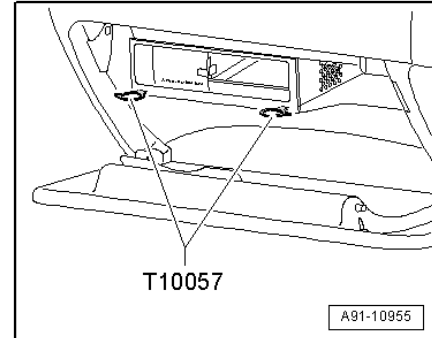

## Removing and installing glove box

### Removing

- Equipment version with storage box in glove box: Release retaining hooks (left and right) using a screwdriver -arrow- and pull storage box out of glove box.
- Equipment or country-specific version: Remove bolt -1- (top, side).
- Country-specific version with impact damper: Remove bolt -2-.

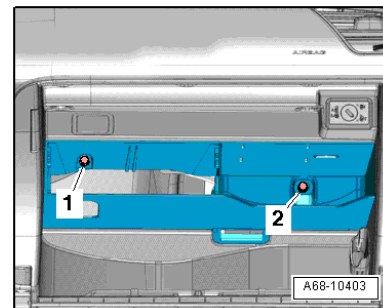
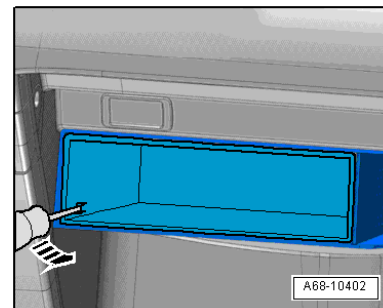

- Remove side dash panel cover (passenger side)
- Open glove box lid and unscrew bolts -arrows-.



### Note

- The number of bolts depends on the country-specific version.
- Detach glove box and pull it out far enough so that you can unplug electrical connector at main connector.
- 



Open the passenger side dash side cover using a trim removal tool. Unscrew the side bolt.

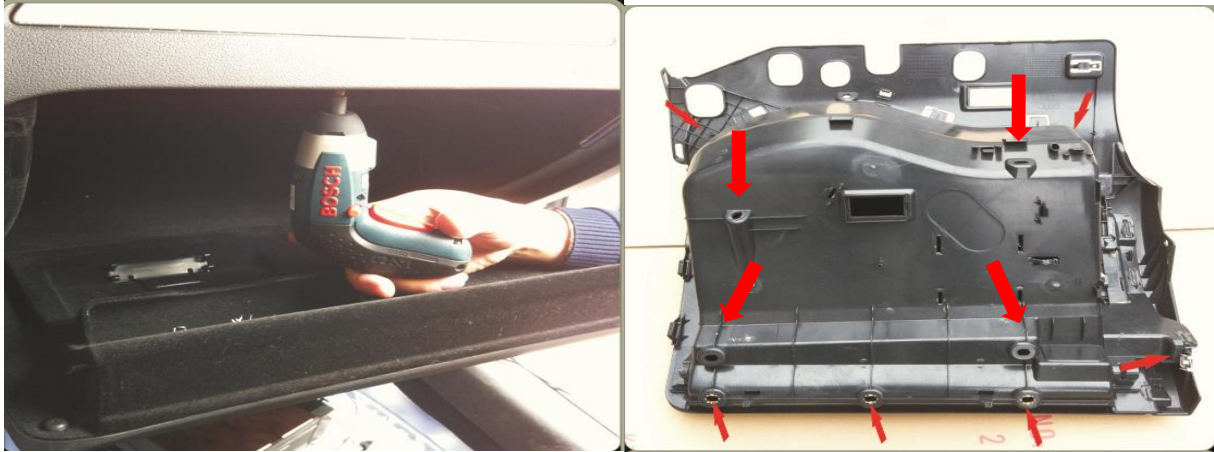

**Passing main cable to screen compartment**

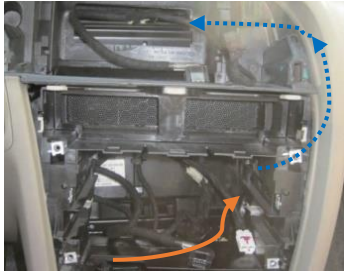

- Start to pass the main cable through the openings in the back of radio/head unit compartment holding 'white main male plug of the cable'. You need to pass the cable with both arms working in both radio compartment hole and the side hole of the glove compartment.

- Continue to read next page



Following the diagram below, route the cables properly.

## Main Connector Pin Assignment (!!Male Plug View!!)

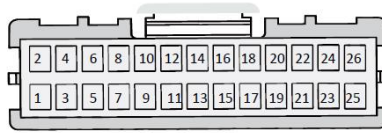

MAIN CONNECTOR			
1	GROUND	14	REAR CAMERA VIDEO CVBS INPUT
2	BATTERY 12+ INPUT	15	DVR VIDEO CVBS INPUT
3	ACCESSORY 12V+ OUTPUT	16	GROUND
4	HANDFREE SOUND OUTPUT POSITIVE	17	CANBUS 1 LOW
5	GROUND, Zero-ohm link	18	CANBUS 1 HIGH
6	HANDSFREE CONTROL OUTPUT 1	19	CANBUS 2 LOW
7	AUDIO OUT(RCA) RIGHT POSITIVE	20	CANBUS 2 HIGH
8	AUDIO OUT(RCA) LEFT POSITIVE	21	CANBUS 3 LOW*
9	HANDSFREE CONTROL GROUND	22	CANBUS 4 HIGH*
10	USB DATA POSITIVE (DP)	23	REAR CAMERA POWER 12V+ OUTPUT
11	USB POWER 5V (VCC)	24	DVR POWER 12V+ OUTPUT
12	USB DATA NEGATIVE (DM)	25	AUXILIARY INPUT DETECTION INPUT
13	GROUND	26	TURN SIGNAL DETECTION INPUT



3G MMI CONTROL CONNECTORS (JOIN EACH OTHER)



HANDSFREE SPEAKER (CENTRE SPEAKER)  
CONNECTORS: MALE TO SPEAKER, FEMALE TO  
FACTORY SPEAKER MALE CONNECTOR

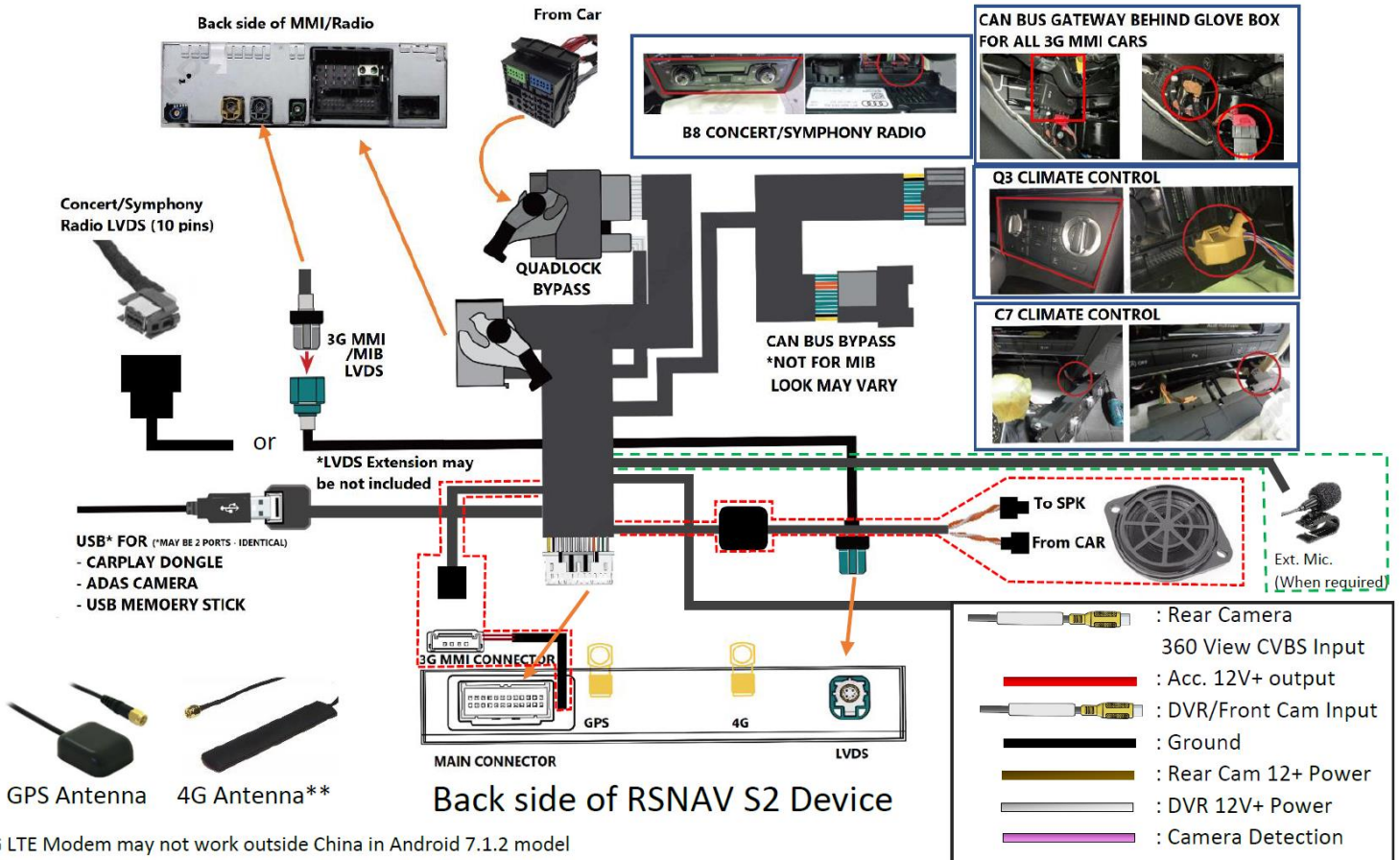

\*\* 4G LTE Modem may not work outside China in Android 7.1.2 model

## For Concert/Symphony Radio unit installation only



Remove the climate control panel, unplug the far right large connector, and install the T-bypass supplied with the kit. It is not required to remove the glove box and install bypass connector to the CAN BUS gateway.

## For 3G MMI unit installation only



- Locate CANBUS gateway near the glove compartment and install the bypass line. **The car must be turned off when disconnecting and connecting plugs into the CANBUS gateway. Also, do not press start button or key into ignition while CANBUS gateway wiring is disconnected. This will cause many electrical problems and error codes.**



- Make sure every pin is well connected without any pin escape or bent. This is the most critical electronic component for your car and many problems will arise if you don't connect it properly.



- If you have error code with a particular system (e.g. parking break, lane assist) or the car does not start, inspect the CANBUS gateway bypass cable and pins thoroughly. In some cases, male pin on our CANBUS gateway receptacle may be bent or escaped if there was excessive force to plug the connector.



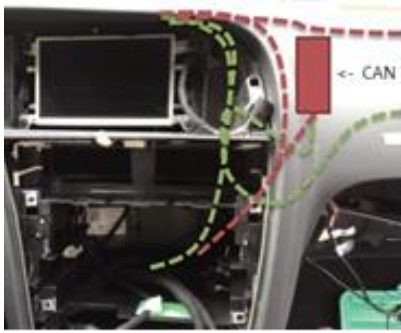

Any cable route must avoid the CAN BUS in any cost. Otherwise, you will have weak WIFI signal, abnormal WIFI downlink speed, noise from speakers and abnormalities.

The Green is the proper route, and the red is the common mistake and bad route.



Join all the connectors properly. Make sure all the connection is tight and well connected. For the quad lock plug there is a lever to release/lock plugs each other also there is latches inside the female plug to make sure tight connection. The female quad lock plug completely covers the male quad lock plug and there must be no escape of the male quad lock.

### Installing Centre Speaker Bypass and routing USB Cable port



Remove the center dash speaker trim using a trim removal wedge, and unscrew the center speaker holding screws. Install the speaker bypass stemming from the main harness.



Route USB port into the glove box compartment by opening a hole using a drill or let out the USB port on the passenger side left side foot wall by probing into trim gaps.

## Installing GPS and Cellular antennas

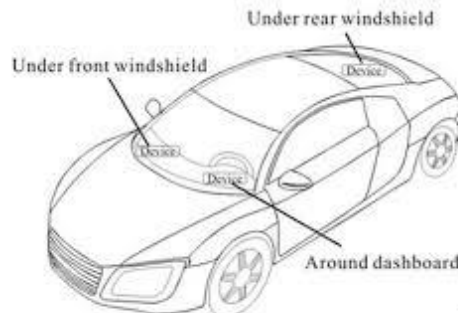
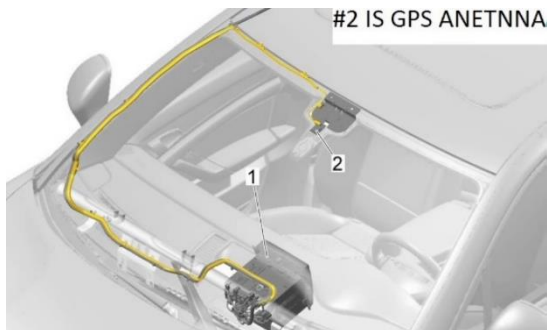

- Under the dash board below the front windshield;

- Preferred location of both antenna is near the rear-view mirror. However, signal reception may vary as each vehicle has different rate of signal penetration.
- Using GPS test plus app as well as mobile signal checking tools available from Google Play Store to determine the best location and angle of the antennas.

## Removing A-pillar trim to pass the antenna wires to windshield.



### WARNING

**There is a curtain airbag behind this trim, and it may ignite if not be careful.**

- Switch on ignition.  
With ignition switched on, disconnect battery earth wire.
- Before handling pyrotechnic components and restraint systems (e.g. unplugging electrical connector) the mechanic must discharge static electricity by briefly touching the door striker plate, or similar.



### WARNING

Observe safety regulations for pyrotechnic components

- Use a screwdriver to carefully unclip cap -1- with "airbag" symbol from A-pillar trim (top).
- Remove bolt -2-.
- Starting at top, carefully unclip A-pillar trim (top) -3- with removal wedge -3409--arrow A-.
- Pull A-pillar trim (top) out of dash panel -arrow B- and detach.

Installing



### WARNING

Observe safety regulations for pyrotechnic components  
Take care not to trap curtain airbag when fitting A-pillar trim (top).

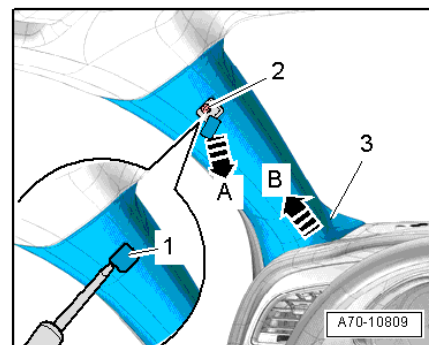

Installation is carried out in the reverse order; note the following:



**Note**

If there are still trim clips in the body mounting points, they must be removed and inserted in the trim when installing. Check the clips for damage or deformation and renew them if necessary.

- Use a thread tap to remove any residual locking fluid from threaded hole for bolt for A-pillar trim (top).



**Note**

If the threaded hole is not cleaned, there is a danger of the new bolt seizing when being screwed in and then shearing off the next time you try to remove it.

- Insert A-pillar trim (top) -1- in mounting -2- of dash panel and sill panel trim (front) in direction of -arrow-.
- Clip in A-pillar trim (top) and fold over lip of door seal.

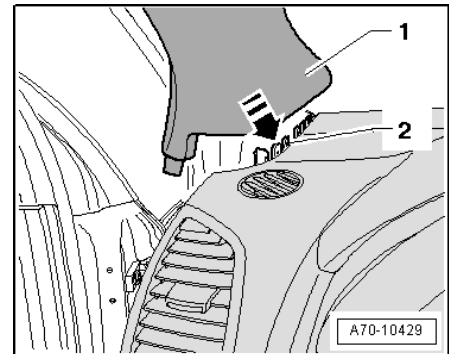

**It is not necessary to remove roof lining to pass a wire. Pull down lining by a bit of force and squeeze in the antenna wires.**

**Activating External Audio Input** **If this is not done, there will be no sound output**

**Method 1. (B8.5 Concert/Symphony or 3G MMI only)**

If you have AMI to AUX adaptor, please plug it in to MMI/AMI plug to activate external audio source in Media tab of your Radio/MMI. **If you have Concert/Symphony radio and your car model year is 2008 ~ 2012, do not use this method, but code your radio using Vag Com or OBD Eleven.**



Plug this side to your AMI in glovebox or centre armrest

Do not plug this side to anything



## Method 2. Coding the system using Vag Com (or OBD Eleven)

### Concert/Symphony radio

Using VAG COM,  
At Radio module-> coding-> long coding helper

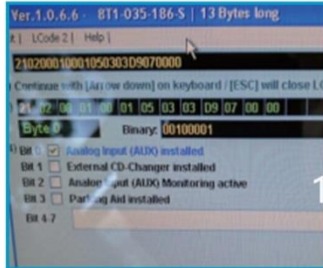

Byte 0, check AUX installed.

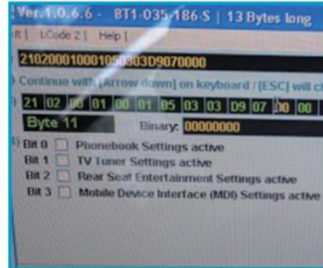

Byte 11, Uncheck Mobile Device Interface(MDI) setting active.



This should activate the AUX

### 3G MMI/MMI+

Enabling Aux input in MMI

1. Preparation: Enable Green menu using VAGCOM or OBD Eleven  
Connect with module 5F – Control Head.  
Choose procedure 10 – Adaptation.  
Choose Perquisite Channel 6.  
Read stored value. By default it should be 0.  
Change value to 1 and save it.  
Read stored value. Now it should be 1.  
Exit

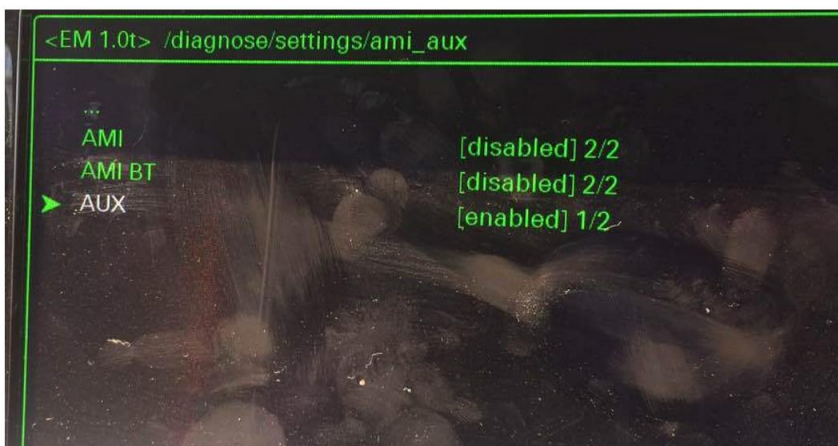

Audi MMI 3G AUX activation procedure

1. Turn key into II position and wait for the MMI 3G system to start. You can also use keyless buttons.
2. Press and hold buttons MENU(or SETUP) and CAR.
3. After couple of seconds hidden green menu will appear. You can now release the buttons.
4. Navigate to diagnose → settings → AMI/AUX.
5. Change the value of “AUX” “disabled” to “enabled” preserving other options.
6. Press RETURN and CAR buttons at the same time to exit hidden green menu.
7. Restart the MMI

## 8.8-inch mounting instruction for Sedan



Install the metal plate to the position of original LCD screen. **Mind that the screw tabs have wide holes for the installer to mount new screen in an exact position. Do not screw tight before you confirm the fitment of LCD screen with the provided housing. If necessary, make the screw tabs trimmed down and screw holes wider so that you can mount it further left.** If the position is right, then screw the main device to two upper screw taps.



Connect new hazard flasher using provided hazard flasher extension.



Reuse every metal clip and rubber O ring, rubber stopper from the original LCD trim.



PCB with BL is for Pass. Airbag Off indicator equipped vehicle (e.g. the US)



For 8.8" 3G MMI model there are single wire plugs tabbed with label saying 09-12 or 13-15, choose right one for your car model(Preface lift or facelift). This one is for automatic aux switching.



For 3G MMI devices This connectors must be manually connected to make sure MMI console to work properly.



## 10.25, 12.3-inch mounting instruction



**Metal Frame goes to Replacement the factory LCD location.**

**Replacement Hazard Flasher**

**Fixture screws to the metal frame**

**10.25" Device unit**



(optional) If you want secure installation of the mount, using a cutting tool, empty out the LCD fascia of the original LCD frame and remove the original hazard flasher. You can skip this process and partially screw down to preserve OEM plastic, but not recommended.



- Install the metal plate to the position of original LCD screen. Mind that the screw taps in four edges have wide holes for the installer to mount new screen the exact position. Do not screw tight before you confirm the fitment of LCD screen with the provided housing.

- If the position is right, then screw down plastic supporting frame with four screws.

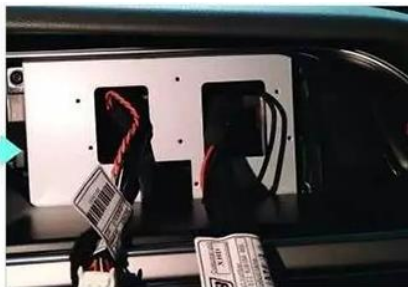

- Pass the wires through two holes. Identify what wire should pass which hole.



- Connect new hazard flasher using provided hazard flasher extension.



Mount the head unit by sliding into guide rails and open the screw covers in the back side of the main head unit (tablet) (screw down two large screws to fasten the tablet permanently for 10.25" device).

For 10.25" unit, there are four connectors.

1. 28 pin white main plug for various wires including power
2. Gold plated antenna connector for mobile modem
3. Gold plated antenna connector for GPS
4. Audi original display signal (LVDS) input port.

For LVDS input port, there is a conversion extension included in the package depending on your original infotainment type.



*In some model, e.g. 10.25", the connection is made through included conversion extension.*

or



*For 3G MMI, 8pin black connector (power supply) is no longer used.*

insert in right direction.

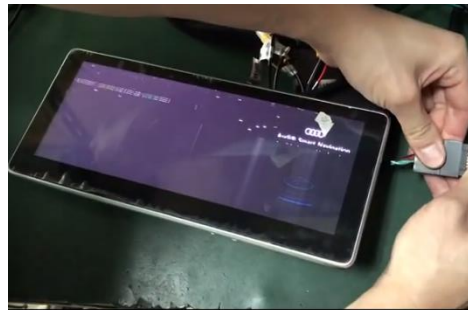

For 10pin LVDS cable, if original Audi screen scrambles like the picture, then you connected the original 10 pin male plug upside down. Verify the plug direction and

## Clearing 'External Audio Source Active' message in instrument cluster

When you are using the steering wheel left roller button on Android, your instrument cluster would keep show 'External Audio Source Active' message. To clear this message and bring back the speedometer, use the Reset button on the bottom of the right Multifunction wiper control switch stalk instead of any other button in the steering wheel.

