

Unistrut
GPP1000T
with slotted holes on top

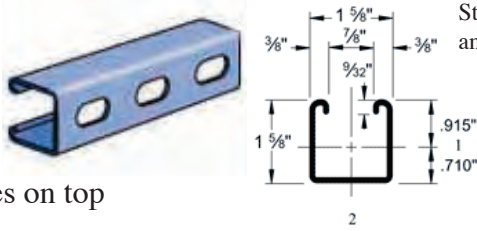

Stocked in 10 ft
and 20 ft lengths.

Unistrut
GPP1001

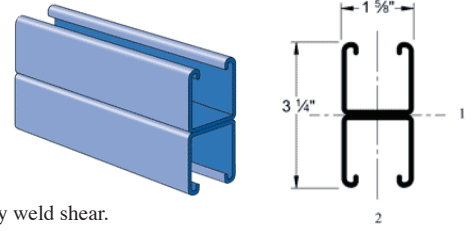

*Load limited by weld shear.

Span (in)	Max Allowable Uniform Load (lbs)	Defi at Uniform Load (in)	Uniform Loading at Deflection			Span (in)	Max Allowable Uniform Load (lbs)	Defi at Uniform Load (in)	Uniform Loading at Deflection		
			Span /180 (lbs)	Span /240 (lbs)	Span /360 (lbs)				Span /180 (lbs)	Span /240 (lbs)	Span /360 (lbs)
24"	1,690	.06	1,690	1,690	1,690	24"	*3,500	.02	*3,500	*3,500	*3,500
36"	1,130	.13	1,130	1,130	1,130	36"	3,190	.07	3,190	3,190	3,190
48"	850	.22	850	760	500	48"	2,390	.13	2,390	2,390	2,390
60"	680	.35	650	480	320	60"	1,910	.20	1,910	1,910	1,620
72"	560	.50	450	340	220	72"	1,600	.28	1,600	1,600	1,130
84"	480	.68	330	250	160	84"	1,370	.39	1,370	1,240	830
96"	420	.89	250	190	130	96"	1,200	.51	1,200	950	630
108"	380	1.14	200	150	100	108"	1,060	.64	1,000	750	500
120"	340	1.40	160	120	80	120"	960	.79	810	610	410
144"	280	2.00	110	80	60	144"	800	1.14	560	420	280
168"	240	2.72	80	60	40	168"	680	1.53	410	310	210
192"	210	3.55	60	50	--	192"	600	2.02	320	240	160
216"	190	4.58	50	40	--	216"	530	2.54	250	190	130
240"	170	5.62	40	--	--	240"	480	3.16	200	150	100



Spring Nut

Cat. #	Size
GPP1006	1/4"
GPP1007	5/16"
GPP1008	3/8"
GPP1010	1/2"

Also available without spring.



Nut w/Post

Cat. #	Size
GPP2381	1/2"



Square Flat Washers

Cat. #	Size
GPP2862	5/16"
GPP2863	3/8"
GPP2864	1/2"



2 Hole Corner # GPP1026

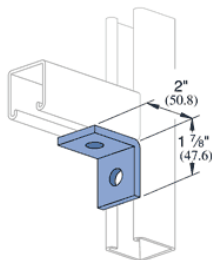

Z Connector

-U Clamp that allows you to run strut in three different directions. The only rated clamp Unistrut recommends.
GP1047

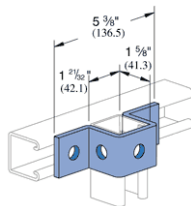

Elongated Z Bar # GPP2346

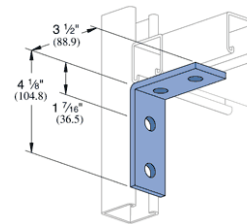
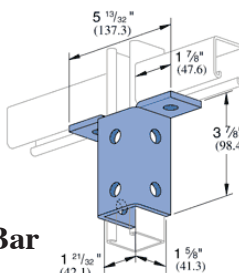

Splicing Clamps

-U Clamp that encapsulates the track.
-It handle 4 Spring Nuts (not included).
GPP1377

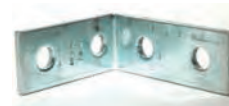

4 Hole Corner # GPP1325

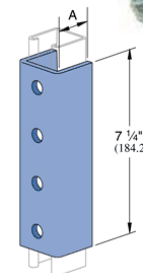

Part Number	For Use With	Wt/100 pcs Lbs (kg)
P1377	P1000, P1100, P2000	265 120.2
P4377	P3300, P4000, P4100	176 79.8
P5077	P5000	
P5577	P5500	

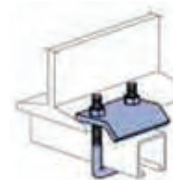

#GPP2785



#GPP2786

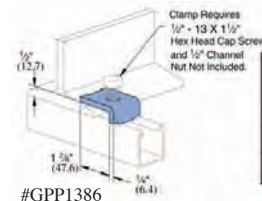

#GPP1386

Clamp Requires 1/2" - 1/8 X 1 1/2" Hex Head Cap Screw and 1/4" Channel Nut Not Included.

Channel Style	Design Load Each (Use in Pairs Only) Lbs (kg)
P1000	600 272.2
P1100	500 226.8
P2000	450 203.1

Beam Clamps

Used in pairs only.

Cat. #	Size
GPP2785	P1000
GPP2786	P1001
GPP1386	Both

Unistrut & Telespar



Trolley Beam Support
GPP1834

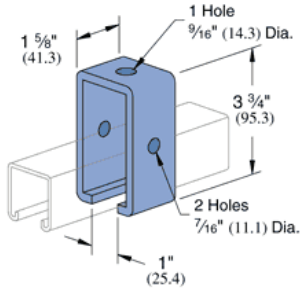

Requires 3/8" x 2 1/2" Bolt and 3/8" Nut (not included)
Design Load 1200 Lbs (544.3 kg)

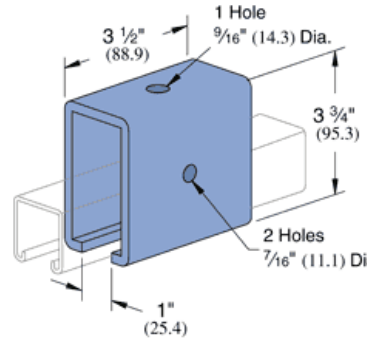

Trolley Support Coupler
GPP1834A

Design Load 2500 Lbs (1,134.0 kg)

Requires 3/8" x 2 1/2" Bolt and 3/8" Nut (not included)

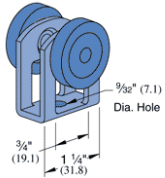

Clevis Material: 12 gauge.
*Wheel bearings are stainless steel, and should not be lubricated.
† "N" indicates acetal wheels.

Light Duty Single Trolley
GPP2749

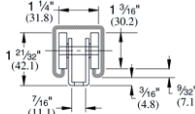

Part Number	Design Load Lbs (kg)	W/100 pcs Lbs (kg)
P2749	50	21
P2749N	22.7	9.5
	10	13
	4.5	5.9



Single Trolley
GPP2949

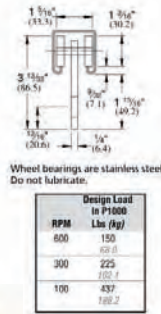

Wheel bearings are stainless steel. Do not lubricate.

RPM	Design Load in P1000 Lbs (kg)
600	150
300	225
100	437
	199.2

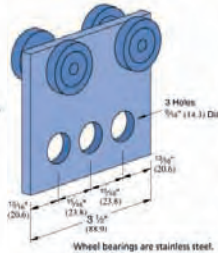

Wheel bearings are stainless steel. Do not lubricate.



Master Trolley
GPP2950

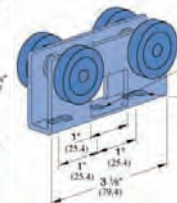

Clevis Material: 12 gauge.
*Wheel bearings are stainless steel, and should not be lubricated.

Part Number	Design Load Lbs (kg)	W/100 pcs Lbs (kg)
P2750	100	35
P2750N	20	32
	9.3	14.3



Light Duty Master Trolley
GPP2750

We stock Telespar, not to be confused with Telestrut (by Unistrut). We prefer the Telespar tubing because it offers a better range of sizes (1-1/2" - 2-1/4") and it is available in 24 foot lengths. In addition Telespar has 7/16" holes 1" on center as opposed to Unistrut Telestrut which has 9/16" holes that are 1-7/8" on center.

Telespar

- Made of rustproof, galvanized steel
- Telespar sleeves together
- Stock Length: 20 feet



Cat. #	Tube Size
GPTEL112	1-1/2"
GPTEL134	1-3/4"
GPTEL2	2"
GPTEL214	2-1/4"
GPTEL212	2-1/2"

Junior Top Beam Clamp



Cat. #	Rod Size	Max. Rec. Load (lbs)
HR119238	3/8"	350
HR119212	1/2"	470
HR119258	5/8"	550
HR119234	3/4"	700

Top Beam Clamp



Cat. #	Rod Size	Max. Rec. Load (lbs)
HR1192W38	3/8"	400
HR1192W12	1/2"	500
HR1192W58	5/8"	800
HR1192W34	3/4"	900