

## Wood & Metal

### Countersinks

- Produces clean 82° countersinks in steel with this tool made of High Quality Tool Steel

Cat. #	Diameter
HT04-140	1/2"
HT04-142	5/8"
HT04-144	3/4"



### Wood Countersinks

#### #HT04-137

- Produces clean 82° countersinks in wood and plastic
- Fits 1/4" and larger drill chucks

### Wood Countersinks - For a bit brace

#### #HT04-139

- Produces clean 82° countersinks in wood and plastic
- To be used with a bit brace only

### Dowling Jig

#### #HT04-059

- Furnished with a set of 6 guides

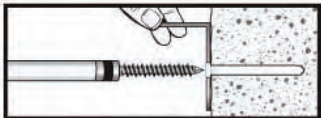
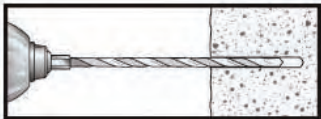

### Tapcon Tool

#### #HT1000

- Ensures the precise drilling of pilot holes when installing Tapcon anchors
- A masonry drill bit with a carbide tip
- Tapcon drill bits are listed below and are sold separately



### Tapcon Drill Bits

- For installing 3/16" Tapcon fasteners, use 5/32" Tapcon drill bit
- For installing 1/4" Tapcon fasteners, use 3/16" Tapcon drill bit

Cat. #	Size	Useable Overall	
		Length	Length
HTDBT5/32	5/32"	4"	6"
HTDBT3/16	3/16"	4"	6"

## Screw-Mate® Adjustable Drill & Countersinks

- Drills for screw thread, body size, countersinks, and counterbores
- Adjustable for different length of screws
- 1/4 shank — fits chucks of power drill or hand drill

Cat. #	Screw Size No.
HT04-621	6
HT04-622	8
HT04-623	10
HT04-624	12

## Speedbor 2000 Wood Boring Bit Sets

- Patented Microgroove cutting edge with spurs
- Bits are also sold separately



### Set of 8

#### #HT341008

- Contains the following eight sizes of spade bits in a plastic kit: 3/8", 1/2", 5/8", 3/4", 7/8", 1", 1 1/4", 1 1/2"

### Set of 13

#### #HT88894

- Contains the following thirteen sizes of spade bits in a plastic kit: 1/4", 5/16", 3/8", 7/16", 1/2", 9/16", 5/8", 11/16", 3/4", 13/16", 7/8", 15/16", 1"

## Speedbor Boring Bits

- Length: 6" with a 1/4" shank

Cat. #	Diameter	Cat. #	Diameter
HT88804	1/4"	HT88811	11/16"
HT88805	5/16"	HT88812	3/4"
HT88806	3/8"	HT88813	13/16"
HT88807	7/16"	HT88814	7/8"
HT88808	1/2"	HT88815	15/16"
HT88809	9/16"	HT88816	1"
HT88810	5/8"		



## SDS Rotary Hammer Bits

Cat. #	Size	Useable Overall	
		Length	Length
HTDBS5/32	5/32"	4"	6"
HTDBS3/16	3/16"	4"	6"
HTDBS1/4	1/4"	4"	6"
HTDBS5/16	5/16"	4"	6"
HTDBS3/8	3/8"	4"	6"
HTDBS7/16	7/16"	4"	6"
HTDBS1/2	1/2"	4"	6"
HTDBS9/16	9/16"	4"	6"
HTDBS5/8	5/8"	6"	8"
HTDBS3/4	3/4"	6"	8"
HTDBS7/8	7/8"	6"	8"
HTDBS1	1"	8"	10"



# Drill Bits

## Drill Sets

Cat. #	Description
HT113	1/16 - 1/4 by 64ths
HT115	1/16 - 1/2 by 32nds
HT121	1/16 - 3/8 by 64ths
HT126	A - Z 26 pcs
HT129	1/16 - 1/2 by 64ths
HT129-C	1/16 - 1/2 by 64ths

C denotes Very Strong- Cobalt Steel

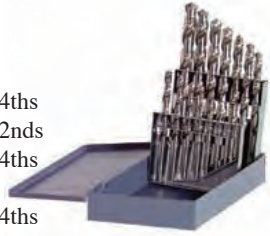

## Carbide Masonry Drill Bits

Cat. #	Size	Overall Length
HTDBM1/8	1/8"	2 1/2"
HTDBM3/16	3/16"	3"
HTDBM1/4"	1/4"	4"
HTDBM5/16	5/16"	4"
HTDBM3/8	3/8"	4"
HTDBM1/2	1/2"	6"
HTDBM5/8	5/8"	6"
HTDBM3/4	3/4"	6"

## General Purpose Drill Bits

• For wood and metal

Cat. #	Size	Overall Length
HTDB1/16	1/16"	1 7/8"
HTDB5/64	5/64"	1 11/16"
HTDB3/32	3/32"	1 3/4"
HTDB7/64	7/64"	1 13/16"
HTDB1/8	1/8"	1 7/8"
HTDB9/64	9/64"	1 15/16"
HTDB5/32	5/32"	2 1/16"
HTDB11/64	11/64"	1 1/8"
HTDB3/16	3/16"	2 3/16"
HTDB13/64	13/64"	2 1/4"
HTDB7/32"	7/32"	2 3/8"
HTDB15/64"	15/64"	2 7/16"
HTDB1/4"	1/4"	2 1/2"
HTDB17/64"	17/64"	2 5/6"
HTDB9/32	9/32"	2 11/16"
HTDB19/64	19/64"	2 3/4"
HTDB5/16	5/16"	2 13/16"
HTDB21/64	21/64"	2 13/16"
HTDB11/32	11/32"	3"
HTDB23/64	23/64"	3 1/16"
HTDB3/8	3/8"	3 1/8"
HTDB25/64	25/64"	3 1/4"
HTDB13/32	13/32"	3 15/16"
HTDB27/64	27/64"	3 3/8"
HTDB7/16	7/16"	3 7/16"
HTDB29/64	29/64"	3 9/16"
HTDB15/32	15/32"	3 5/8"
HTDB31/64	31/64"	3 11/16"
HTDB1/2	1/2"	3 3/4"

## Cobalt Drill Bits

• For wood and metal-superior quality

Cat. #	Size	Overall Length
HTDBC1/16	1/16"	1 7/8"
HTDBC5/64	5/64"	1 11/16"
HTDBC3/32	3/32"	1 3/4"
HTDBC7/64	7/64"	1 13/16"
HTDBC1/8	1/8"	1 7/8"
HTDBC9/64	9/64"	1 15/16"
HTDBC5/32	5/32"	2 1/16"
HTDBC11/64	11/64"	1 1/8"
HTDBC3/16	3/16"	2 3/16"
HTDBC13/64	13/64"	2 1/4"
HTDBC7/32"	7/32"	2 3/8"
HTDBC15/64"	15/64"	2 7/16"
HTDBC1/4"	1/4"	2 1/2"
HTDBC17/64"	17/64"	2 5/6"
HTDBC9/32	9/32"	2 11/16"
HTDBC19/64	19/64"	2 3/4"
HTDBC5/16	5/16"	2 13/16"
HTDBC21/64	21/64"	2 13/16"
HTDBC11/32	11/32"	3"
HTDBC23/64	23/64"	3 1/16"
HTDBC3/8	3/8"	3 1/8"
HTDBC25/64	25/64"	3 1/4"
HTDBC13/32	13/32"	3 15/16"
HTDBC27/64	27/64"	3 3/8"
HTDBC7/16	7/16"	3 7/16"
HTDBC29/64	29/64"	3 9/16"
HTDBC15/32	15/32"	3 5/8"
HTDB31/64	31/64"	3 11/16"
HTDB1/2	1/2"	3 3/4"

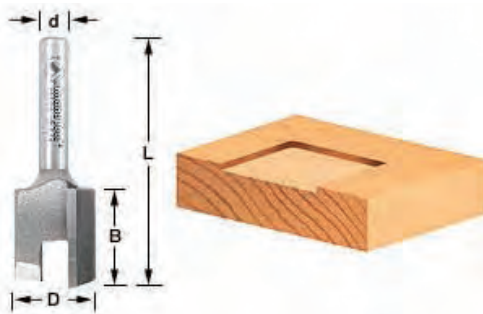

## Mortising Bits

• 2 flute

Cat. #	Cutting Dia.	Cutting Length	Shank Diameter	Overall Length
BTA45500	1/2	3/4	1/4	2
BTA45502	5/8	3/4	1/4	2
BTA45504	3/4	3/4	1/4	2
BTA45505	1-1/4	3/4	1/2	2-1/8

## Panel Pilot Bits

• Single flute

Cat. #	Cutting Dia.	Cutting Length	Shank Diameter	Overall Length
BTA45506	1/4	3/4	1/4	2-1/2
BTA45508	3/8	1	3/8	3
BTA45510	1/2	1-3/16	1/2	3-1/2

## Straight Plunge Cutting Bits

### 1/4" Shank, 2 Flute

• Other sizes available

Cat. #	Cutting Dia.	Cutting Length	Overall Length
BTA45190	1/16	1/4	1-5/8
BTA45192	3/32	1/4	1-3/4
BTA45200	1/8	7/16	2
BTA45201	5/32	7/16	2
BTA45202	3/16	7/16	2
BTA45204	1/4	1/2	2
BTA45208	1/4	3/4	2
BTA45210	1/4	1	2-1/4
BTA45211	1/4	1	2-7/8
BTA45212	9/32	1	2-1/4
BTA45214	5/16	1	2-1/4
BTA45216	3/8	3/4	2
BTA45218	3/8	1	2-1/4
BTA45220	3/8	1-1/4	2-1/2
BTA45222	7/16	1	2-1/8
BTA45223	15/32	3/4	2
BTA45224	1/2	3/4	1-3/4
BTA45226	1/2	1	2-1/8
BTA45227	9/16	3/4	2-1/8
BTA45238	19/32	3/4	2
BTA45228	5/8	3/4	2
BTA45229	11/16	3/4	2
BTA45231	23/32	3/4	2
BTA45230	3/4	3/4	2
BTA45232	13/16	3/4	2
BTA45234	7/8	3/4	2
BTA45236	1	3/4	2



### 1/2" Shank, 2 Flute

• Other sizes available

Cat. #	Cutting Dia.	Cutting Length	Overall Length
BTA45408	1/4	3/4	2-1/2
BTA45414	3/8	1	2-3/4
BTA45415	3/8	1-1/4	3
BTA45416	7/16	1-1/4	3
BTA45418	1/2	1	2-5/8
BTA45420	1/2	1-1/4	2-7/8
BTA45422	1/2	1-1/2	3-1/8
BTA45426	1/2	2	4-1/4
BTA45427	1/2	2-1/2	4-1/2
BTA45428	9/16	1-1/4	2-7/8
BTA45432	5/8	1-1/4	2-7/8
BTA45445	23/32	1-1/4	2-7/8
BTA45440	3/4	1-1/4	2-7/8
BTA45446	7/8	1-1/4	2-7/8
BTA45448	1	1-1/4	2-7/8

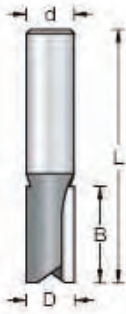

We stock CNC Bits as well!

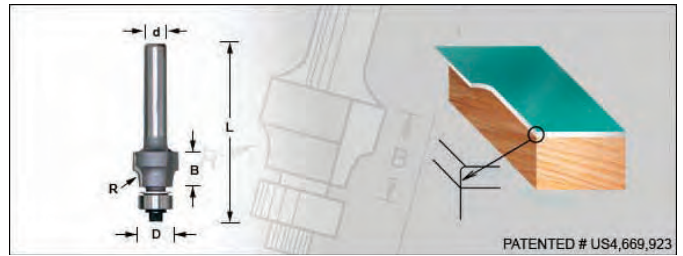

## No File Bits

• With ball bearing guide

Cat. #	Cutting Dia.	Cutting Length	Shank Diameter	Overall Length
BTA47150	5/8	3/8	1/4	1-7/8
BTA47152	5/8	3/8	1/2	2-1/8
BTA47154	5/8	3/8	1/4	1-7/8

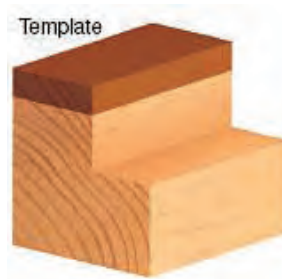

## Flush Trim Plunge Bits

• With upper ball bearing  
• 2 flute  
• Other sizes available

Cat. #	Cutting Dia.	Cutting Length	Shank Diameter	Overall Length
BTA45460	1/2	1	1/4	2-1/2
BTA45460-S	1/2	1/4	1/4	1-5/8
BTA45461	1/2	1-1/4	1/4	2-3/4
BTA45462	5/8	1	1/4	2-3/4
BTA45464	3/4	1	1/4	2-1/2
BTA45466	1	1	3/8	2-7/8
BTA45468	1-1/8	1-1/2	1/2	3-1/2

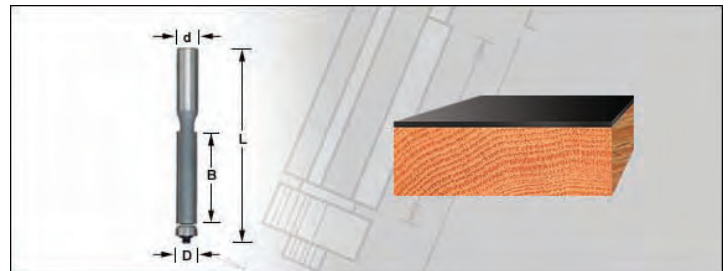

## Flush Trim Bits

• Extra long with ball bearing guide  
• Other sizes available  
• 2 flute

Cat. #	Cutting Dia.	Cutting Length	Shank Diameter	Overall Length
BTA47124	1/2	1-1/2	1/2	3-7/8
BTA47126	1/2	2	1/2	4-1/4

We also stock Bosch bits and can cross reference bits for you.



# Routing Bits

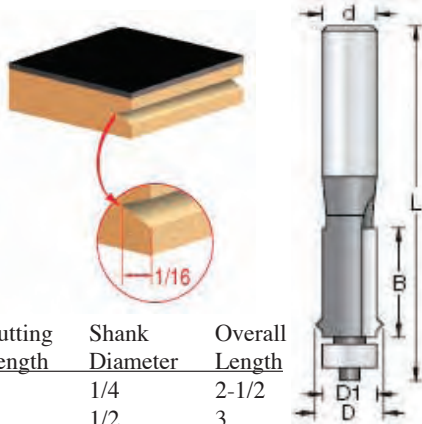

## Flush Trim 'V' Groove Bits

- With ball bearing guide
- 2 Flute

Cat. #	Cutting Dia.	Cutting Length	Shank Diameter	Overall Length
BTA47160	5/8	1	1/4	2-1/2
BTA47162	5/8	1	1/2	3

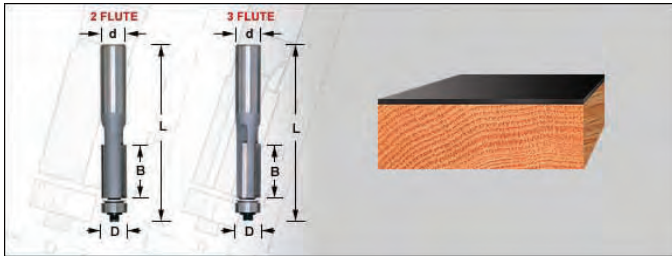

## Flush Trim Bits

2 Flute

Cat. #	Cutting Dia.	Cutting Length	Shank Diameter	Overall Length
BTA47090	1/4	1/2	1/4	2-1/4
BTA47092	1/4	1	1/4	2-1/2
BTA47100	3/8	1	1/4	2-5/8
BTA47102	3/8	1/2	1/4	2-1/8
BTA47104	1/2	1	1/4	2-5/8
BTA47106	1/2	1/2	1/4	2-1/4
BTA47108	1/2	1	1/2	2-3/4

3 Flute

Cat. #	Cutting Dia.	Cutting Length	Shank Diameter	Overall Length
BTA47114	1/2	1	1/4	2-5/8
BTA47116	1/2	1/2	1/4	2
BTA47118	1/2	1	1/2	3
BTA47120	1/2	1/2	1/2	2-5/8

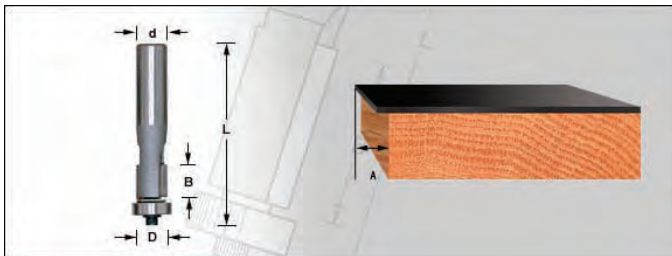

## 'Overhang' Trim Bits

- With ball bearing guide
- 2 Flute

Cat. #	Cutting Dia.	Cutting Length	Shank Diameter	Overall Length
BTA47190	3/8	1/2	1/4	2
BTA47192	1/2	1/2	1/4	2
BTA47194	1/2	1/2	1/2	2-5/8

We stock CNC Bits as well!

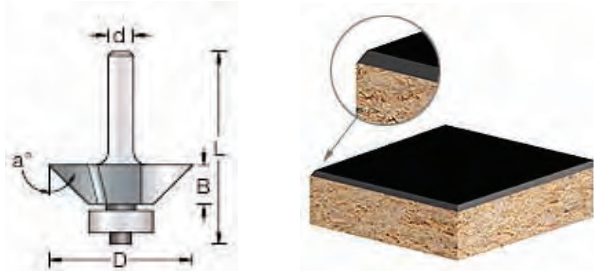

## Bevel Trim Bits

- With ball bearing guide
- 2 Flute

Cat. #	Bevel Degree	Cutting Length	Shank Diameter	Overall Length
BTA47200	15°	9/32	1/4	1-7/8
BTA47202	25°	9/32	1/4	1-7/8
BTA47204	45°	1/4	1/4	1-7/8
BTA47206	25°	7/16	1/4	1-7/8

## Trim Cutter Assembly

- 4 wing
- Included: cutter, arbor and ball bearing guide
- Other sizes available

Cat. #	Cutting Dia.	Cutting Length	Shank Diameter	Overall Length
BTA47404	15°	1/4	1/4	2-3/8

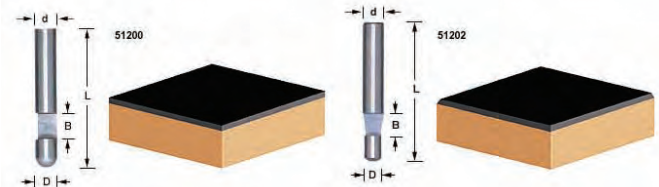
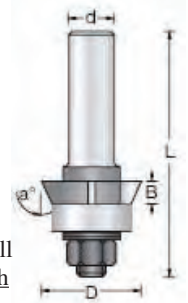

## Single Flute Panel Pilot Bits

Cat. #	Type of Cut	Cutting Dia. & Length	Shank Diameter	Overall Length
BTA51200	Flush	1/4	1/4	1-1/2
BTA51202	7°	1/4	1/4	1-1/2

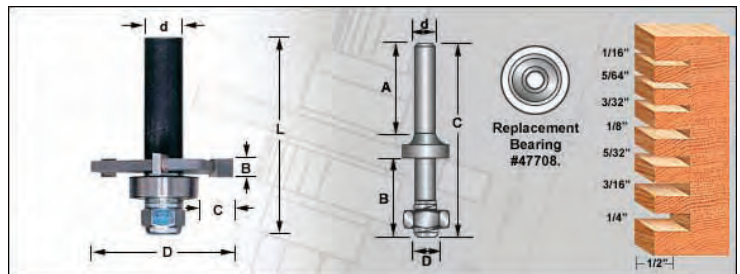

## Slotting Cutter Assemblies

- 3 Wing, 1/2" depth of cut, 1-7/8" diameter, 2-1/8" overall length
- 1/4" Shank

Cat. #	Kerf	Cat. #	Kerf
BTA53400	1/16	BTA53407	5/32
BTA53402	5/64	BTA53408	3/16
BTA53404	3/32	BTA53410	1/4
BTA53406	1/8		



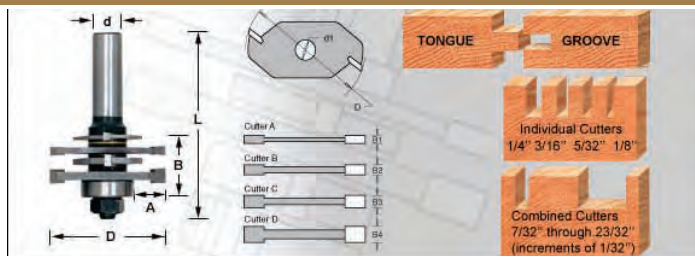

## Quadraset™ 2-Wing Adjustable Slotting Assembly

• 2 flute

Cat. #	'D' Dia	'B' Kerf	Shank Diameter	Overall Length
BTA53600	1-7/8	1/8- <sup>*</sup> 23/32	1/2	3

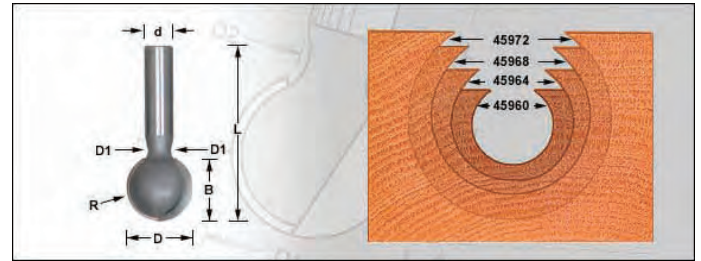

## Ball End Bits

• 2 Flute

Cat. #	'D1' Large Dia	'D2' Minor Dia.	Radius	Shank Dia.	Overall Length
BTA45960	1/2	1/4	1/4	1/2	2-1/4
BTA45964	3/4	5/16	3/8	1/2	2-1/2

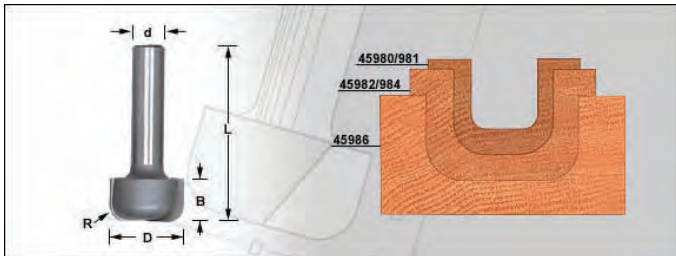

## Bowl & Tray Bits

• 2 flute

Cat. #	Large Dia	Radius	Carbide Height	Shank Diameter	Overall Length
BTA45980	7/16	1/8	1/2	1/4	2
BTA45981	1/2	1/8	1/2	1/4	2-1/8
BTA45982	3/4	1/4	5/8	1/4	2-5/8
BTA45984	3/4	1/4	5/8	1/2	2-5/8
BTA45986	1-1/8	1/4	5/8	1/2	2-5/8

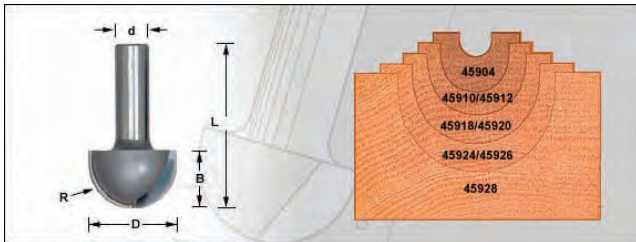

## Core Box Bits

• 2 flute

• More sizes available

Cat. #	Radius	Cutting Dia.	Carbide Height	Shank Diameter	Overall Length
BTA45904	1/8	1/4	1/4	1/4	1-5/8
BTA45906	3/16	3/8	1/4	1/4	1-1/2
BTA45910	1/4	1/2	3/8	1/4	1-1/2
BTA45918	3/8	3/4	7/16	1/4	1-3/4

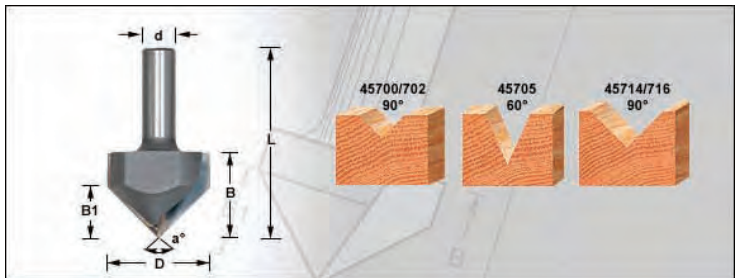

## 90° 'V' Groove Bits

## 60° 'V' Groove Bits

• 2 Flute

Cat. #	Degree	Cutting Dia	Carbide Height	Shank Dia	Overall Length
BTA45700	90°	3/8	7/16	1/4	1-5/8
BTA45704	90°	1/2	1/2	1/4	1-5/8
BTA45705	60°	1/2	5/8	1/4	1-3/4



9°  
TOOL NO. 45800



10°  
TOOL NO. 45803



14°  
TOOL NO. 45804

## Dovetail Bits

• Solid Carbide/3 Flute

Cat. #	Degree	Cutting Dia	Carbide Height	Shank Dia	Overall Length
BTA45800	9°	3/8	3/8	1/4	1-5/8
BTA45802	9°	3/8	3/8	1/2	2-1/8
BTA45803	10°	1/2	5/8	1/4	2-1/2
BTA45804	14°	1/2	1/2	1/4	1-3/4
BTA45806	14°	1/2	1/2	1/2	2-3/8

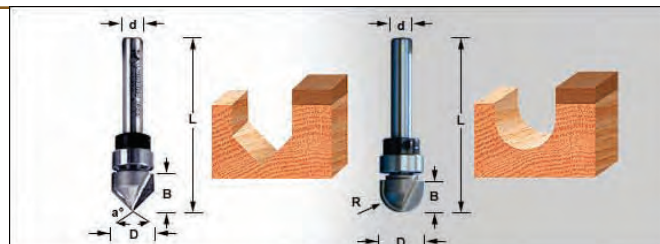

## Core Box, 'V' Groove and Dovetail Bits

• 2 Flute with Upper Ball Bearings

Cat. #	Type	Cutting Dia	Carbide Height	Shank Dia	Overall Length
BTA45750	90° 'V' Groove	1/2	1/2	1/4	2
BTA45850	14° Dovetail	1/2	1/2	1/4	2-1/4
BTA45950	Core Box	1/2	3/8	1/4	2

# Routing Bits



## Chamfer Bits

2 Flute with Ball Bearing Guide

Cat. #	Angle Degree	Large Dia	H Carbide Height	C Cutting Length	Shank Dia	Overall Length
BTA49400	45°	1-1/4	1/2	5/8	1/4	2
BTA49402	45°	1-1/4	1/2	5/8	1/2	2-3/8
BTA49404	45°	2	3/4	1-1/8	1/2	2-1/2
BTA49406	45°	2-1/2	1	1-3/8	1/2	2-7/8
BTA49410	22-1/2°	1-1/4	15/16	7/8	1/2	2-7/8
BTA49414	30°	1-3/8	3/4	7/8	1/2	2-3/4

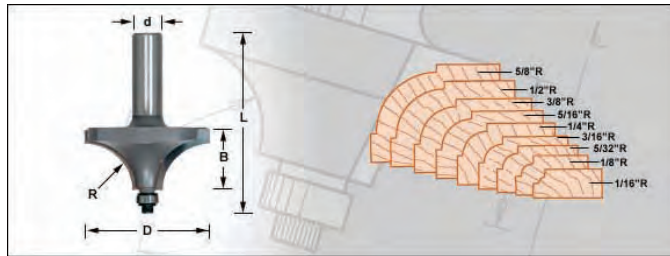

## Beading Bits

• 2 Flute with Ball Bearing Guide

Cat. #	Radius	Large Dia	Carbide Height	Shank Dia	Overall Length
BTA49600	3/16	7/8	1/2	1/4	2
BTA49604	1/4	1	1/2	1/4	2
BTA49612	3/8	1-1/4	5/8	1/4	2-3/16
BTA49616	1/2	1-1/2	3/4	1/4	2-1/4

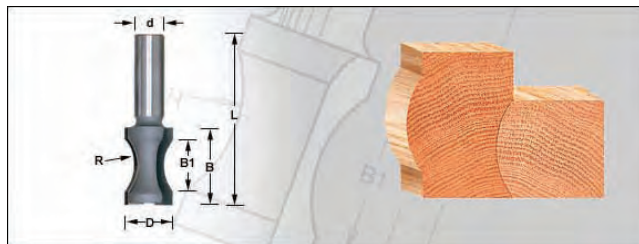

## Convex Edging Bits

• Bull Nose, Half Rounds  
• 2 Flute

Cat. #	Dia	Radius	H Cutting Length	C Cutting Length	Shank Dia	Overall Length
BTA51580	13/16	23/32	1-1/4	27/32	1/4	2-1/2
BTA51582	13/16	23/32	1-1/4	27/32	1/2	2-3/4

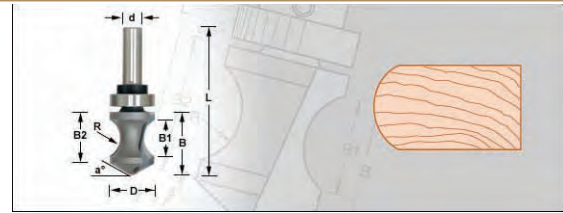

## Hand Grip Plunge Bits

• 2 Flute

Cat. #	Large Dia	Carbide Radius	Shank Height	Overall Dia	Overall Length	Type
BTA51590	1-1/8	1/2	1-9/16	1/2	3-5/8	w/out bearing
BTA51592	1-1/8	1/2	1-9/16	1/2	3-5/8	w/ bearing

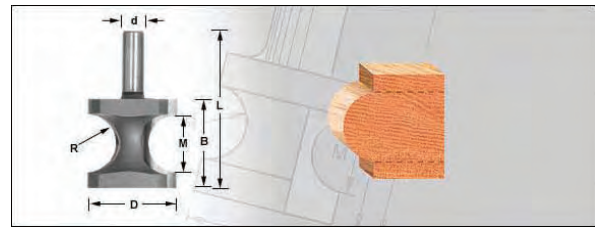

## Bullnose Radius Bits

• 2 flute  
• Other sizes available

Cat. #	M Thick.	R Radius	H Cutting Length	Tool Dia	Shank Dia	Overall Length
BTA51558	1/2	17/64	1	1-1/32	1/2	2-1/2
BTA51560	3/4	3/8	1-5/16	1-1/4	1/2	2-3/4
BTA51562	1	1/2	1-9/16	1-11/16	1/2	3-1/16
BTA51572	3/4	3/8	1-5/16	1-3/8	1/2	3-1/4

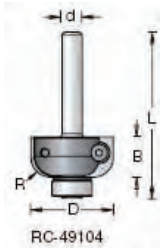

RC-49104



RCK-274

## Cove Bits

• 2 flute with ball bearing guide  
• Other sizes available

Cat. #	Radius	Cutting Dia	Carbide Height	Shank Dia	Overall Length
BTA49104	1/4	7/8	9/16	1/4	2
BTA49112	3/8	1-1/8	9/16	1/4	2
BTA49116	1/2	1-3/8	3/4	1/4	2-1/4

We stock Bosch bits as well and can cross reference bits for you.

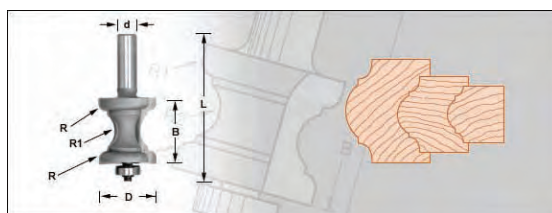

## Bullnose/Cove Edge Bits

• 2 flute with ball bearing guide

Cat. #	Lg Dia	Radius 1	Radius 2	Carbide Height	Shank Dia	Overall Length
BTA51530	1-1/8	1/8	1/4	1	1/2	2-7/8
BTA51532	1-1/4	5/32	5/16	1-3/16	1/2	3
BTA51534	1-3/8	3/16	1/2	1-9/16	1/2	3-3/8



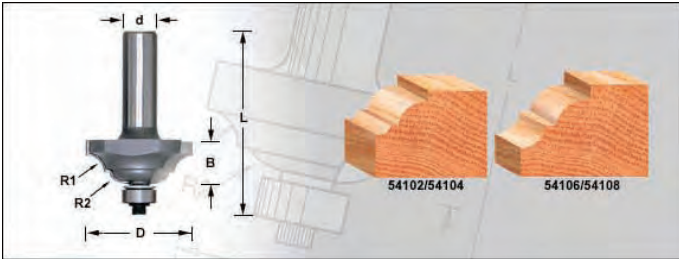

## Classical Bits

- 2 flute with ball bearing guide

Cat. #	Large Dia	Radius 1	Radius 2	Carbide Height	Shank Dia	Overall Length
BTA54102	1-1/4	13/64	5/16	1/2	1/4	2
BTA54104	1-1/4	13/64	5/16	1/2	1/2	2-3/8
BTA54106	1-1/2	15/64	7/32	5/8	1/4	2-1/8
BTA54108	1-1/2	15/64	7/32	5/8	1/2	2-1/2

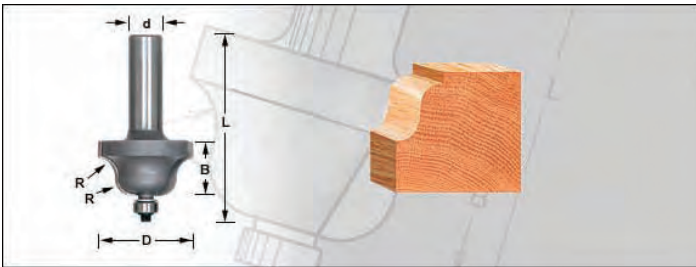

## Roman Ogee Bits

- 2 flute with ball bearing guide

Cat. #	Large Dia	Each Radius	Carbide Height	Shank Dia	Overall Length
BTA49200	1	5/32	5/8	1/4	2-1/8
BTA49202	1	5/32	5/8	1/2	2-1/2
BTA49204	1-3/8	1/4	7/8	1/4	2-1/4
BTA49206	1-3/8	1/4	7/8	1/2	2-5/8

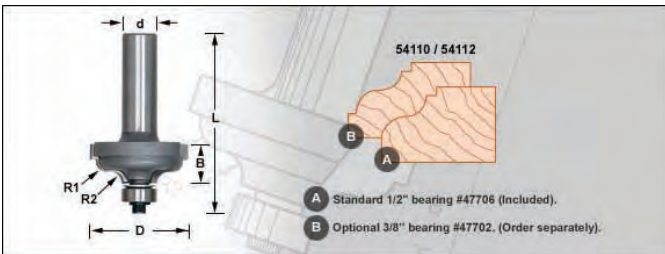

## Ogee Filet Bits

- 2 flute with ball bearing guide
- Other sizes available

Cat. #	Large Dia	Each Radius	Carbide Height	Shank Dia	Overall Length
BTA54127	2-1/4	3/8	15/16	1/2	2-7/8

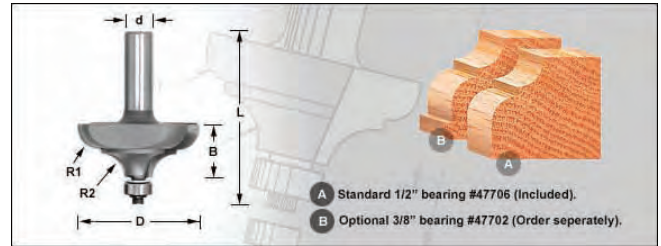

## Classical Ogee Bits

- 2 flute with ball bearing guide

Cat. #	Large Dia	Radius 1	Radius 2	Carbide Height	Shank Dia	Overall Length
BTA54292	1-1/2	3/16	5/16	5/8	1/2	2-1/2

## Ogee Patterns

- 2 flute with ball bearing guide

Cat. #	Large Dia	Each Radius	Carbide Height	Shank Dia	Overall Length
BTA54100	2	11/32	1-1/4	1/2	3-1/8
BTA54135	2	3/8	1	1/2	2-3/4

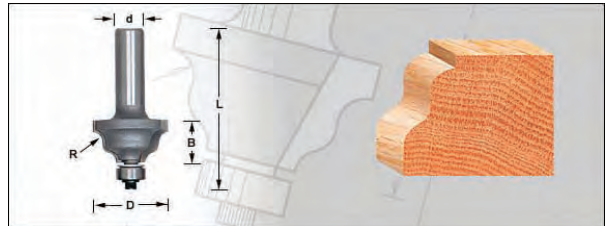

## Wavy Edge Bits

- 2 flute with ball bearing guide

Cat. #	Large Dia	Each Radius	Carbide Height	Shank Dia	Overall Length
BTA54180	1-1/4	5/32	11/16	1/4	2-1/4
BTA54182	1-1/4	5/32	11/16	1/2	2-5/8

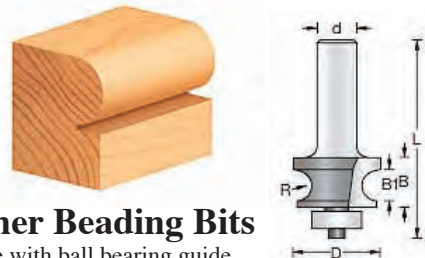

## Corner Beading Bits

- 2 flute with ball bearing guide
- Other sizes available

Cat. #	'R' Radius	Large Dia	'A' Opening	B Height	Carbide Dia	Shank Dia	Overall Length
BTA54160	1/8	7/8	1/4	9/16	1/4	1/4	2-1/8
BTA54162	1/8	7/8	1/4	9/16	1/2	1/2	2-1/2

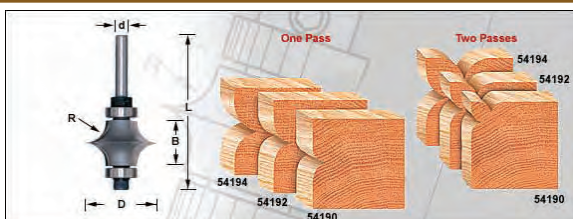

## 'Leaf Edge' Beading Bits

- 2 flute with double ball bearings

Cat. #	R Radius	Large Dia	Carbide Height	Shank Dia	Overall Length
BTA54190	3/16	1	1/2	1/4	2-1/2
BTA54192	1/4	1-1/8	5/8	1/4	2-5/8
BTA54194	3/8	1-3/8	7/8	1/4	2-7/8



# Routing Bits

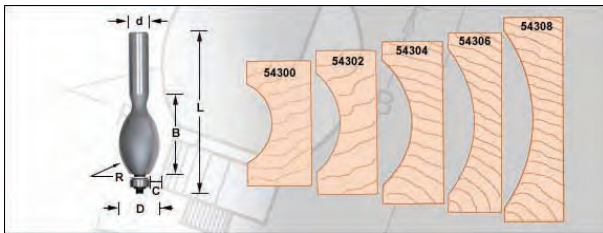

## Edge Fluting Bits

- 2 flute with ball bearing guide
- Other sizes available

Cat. #	Large Dia	Each Radius	Carbide Height of Cut	Shank Dia	Overall Length
BTA54300	3/4	3/16	1/8	1/2	2-5/8
BTA54302	3/4	5/16	1/8	1/2	2-3/4
BTA54306	7/8	3/4	3/16	1/2	3-1/4

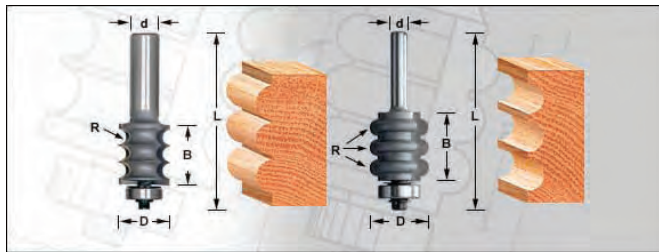

## Drawing Line Bits

- 2 flute with ball bearing guide

Cat. #	Large Dia	Radius 1	Radius 2	Carbide Height	Shank Dia	Overall Length
BTA54350	1	1	3/32	7/8	1/2	2-3/4
BTA54354	1	19/32	5/32	7/8	1/2	2-3/4

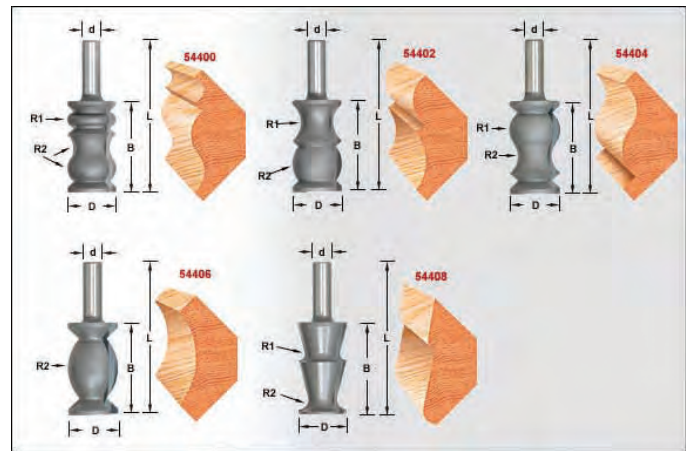

## Multi-Beading/Reeding Bits

- 2 flute with ball bearing guide

Cat. #	Large Dia	Each Radius	Carbide Height	Shank Dia	Overall Length
BTA54211	7/8	1/8	1	1/4	2-5/8
BTA54213	7/8	1/8	1	1/2	3

## Multi-Fluting Bits

- 2 flute with ball bearing guide

Cat. #	Large Dia	Each Radius	Carbide Height	Shank Dia	Overall Length
BTA54215	7/8	1/8	1	1/4	2-5/8
BTA54217	7/8	1/8	1	1/2	3

## Crown Molding Bits

- 2 flute with ball bearing guide
- Other sizes available

Cat. #	Large Dia	Carbide Height	Shank Dia	Overall Length
BTA54400	1-1/4	2-1/4	1/2	3-3/4
BTA54402	1-1/4	2-1/4	1/2	3-3/4

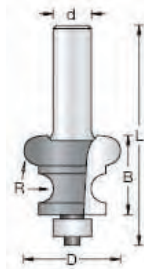

## Matched Bead Bits

- 2 flute with ball bearing guide

Cat. #	Large Dia	Each Radius	Carbide Height	Shank Dia	Overall Length
BTA54184	1	1/8	5/8	1/2	2-1/2
BTA54186	1-1/4	3/16	1	1/2	2-7/8
BTA54188	2	1/4	1-1/4	1/2	3

We stock Bosch bits as well and can cross reference bits for you.

## Architectural Molding Bits

- 2 flute with ball bearing guide
- Other sizes available

Cat. #	R Bead Radius	Large Dia	Carbide Height	Shank Dia	Overall Length
BTA54220	1/8	1	1-11/16	1/2	3-1/4
BTA54250	1/4	1-1/2	2	1/2	3-1/2
BTA54222	1-3/8	1/8	1-5/8	1/2	3-1/2



## Special Interest Molding Bits

- 2 flute with ball bearing guide
- Other sizes available

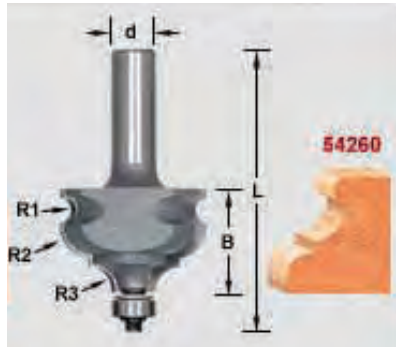

Cat. #	Large Dia	Carbide Height	Shank Dia	Overall Length
BTA54260	1-5/8	1-1/8	1/2	3

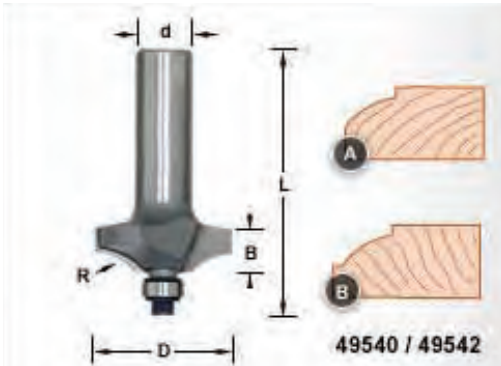

## Handrail/Table Edge Bits

- 2 flute with ball bearing guide
- Other sizes available

Cat. #	Large Dia	Radius	Carbide Height	Shank Dia	Overall Length
BTA49550	2-3/4	1-3/4	5/8	1/2	2-1/2
BTA49554	2-1/2	3/8	3/4	1/2	2-3/4
BTA49556	2-1/2	3/8	3/4	1/2	2-3/4

Ogee



Traditional



Cove



## Raised Panel Bits

- 2 flute with ball bearing guide
- Other types available

Cat. #	Type	Large Dia	Angle Degree	Carbide Height	Shank Dia	Overall Length
BTA54117	Traditional	3-3/8	15°	1/2	1/2	2-3/8
BTA54118	Ogee	2-5/8	---	5/8	1/2	2-1/2
BTA54121	Ogee	1-7/16	---	5/8	1/2	2-1/2
BTA54119	Cove	1-7/16	---	1/2	1/2	2-3/8

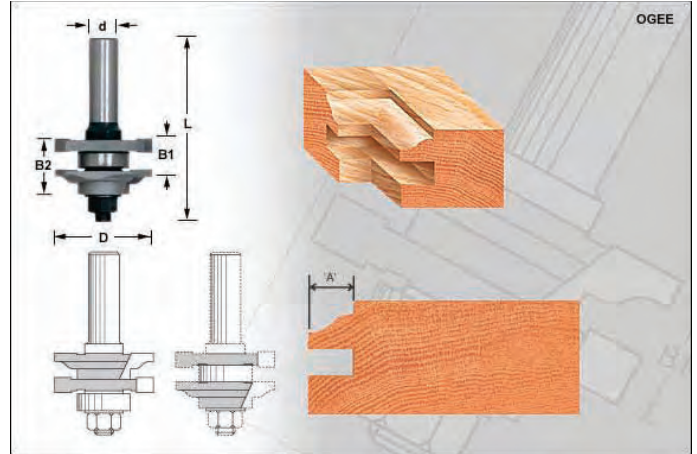

Ogee

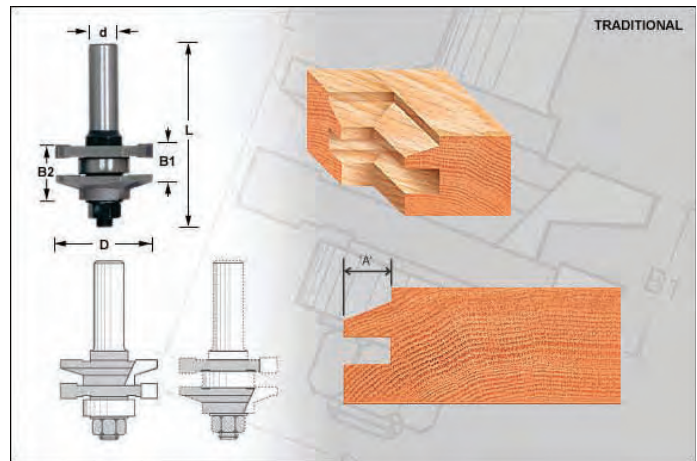

Traditional

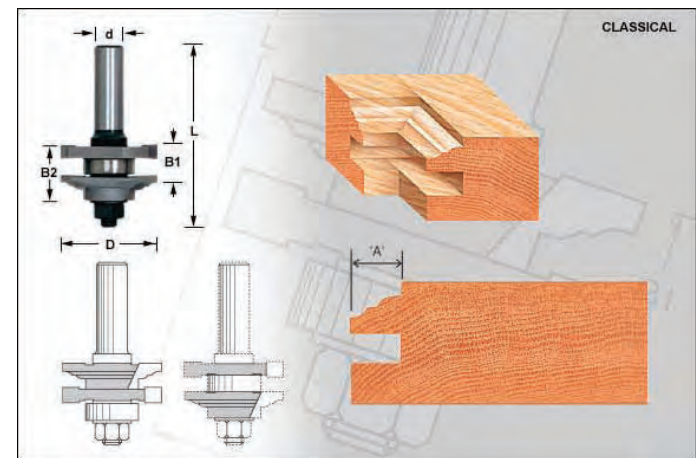

Classical

## Reversible Stile & Rail Assemblies

Cat. #	Pattern Type	Tool Dia	Carbide Height	Shank Dia	Overall Length
BTA55350	Ogee	1-5/8	7/8	1/2	3
BTA55370	Traditional	1-5/8	7/8	1/2	3
BTA55380	Classical	1-5/8	7/8	1/2	3



# Routing Bits



## Rabbeting Bits

- 2 flute with ball bearing guide
- Depth of Rabbet 3/8"

Cat. #	Cutting Dia	Cutting Length	Shank Dia	Overall Length
BTA49300	1-1/4	1/2	1/4	2
BTA49302	1-1/4	1/2	1/2	2-3/8

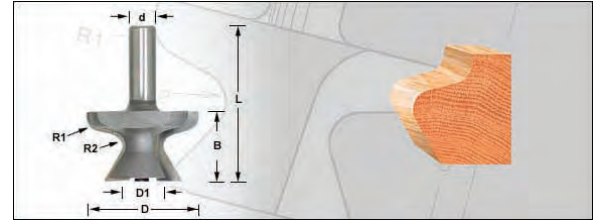

## Finger Grip Bit

- Other sizes available

Cat. #	Large Dia	Each Radius	Carbide Height	Shank Dia	Overall Length
BTA53812	2	1/4	1-1/4	1/2	2-3/4

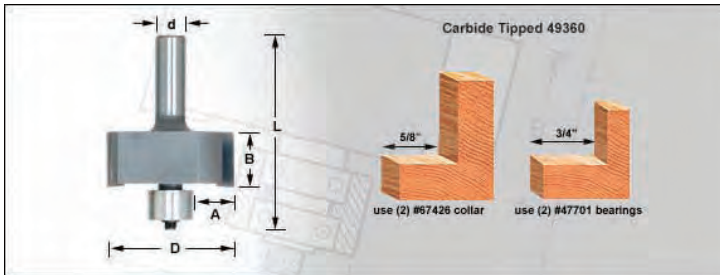

## Super Rabbet Bit

- 2 flute with 4 ball bearings
- Four different rabbet depths

Cat. #	Cutting Dia	Cutting Length	Shank Dia	Overall Length
BTA49360	2	7/8	1/2	3

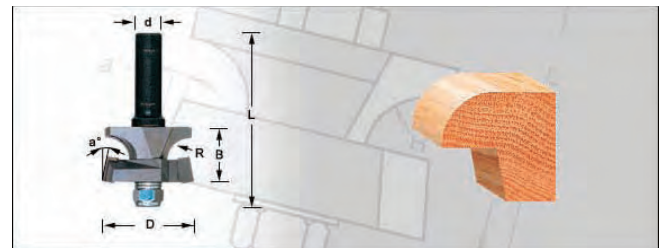

## Door Lip Assembly

- Corner round & taper rabbet
- 2 Flute, complete assembly

Cat. #	Cutting Dia	Radius	Carbide Height	Shank Dia	Overall Length
BTA55300	1-9/16	3/8	1	1/2	3

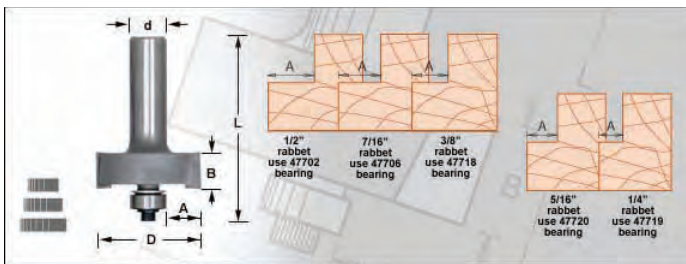

## Multi-Rabbeting Bits

- 2 flute with 4 ball bearings
- Four different rabbet depths

Cat. #	Cutting Dia	Cutting Length	Shank Dia	Overall Length
BTA49340	1-3/8	1/2	1/4	2
BTA49350	1-3/8	1/2	1/2	2-3/8

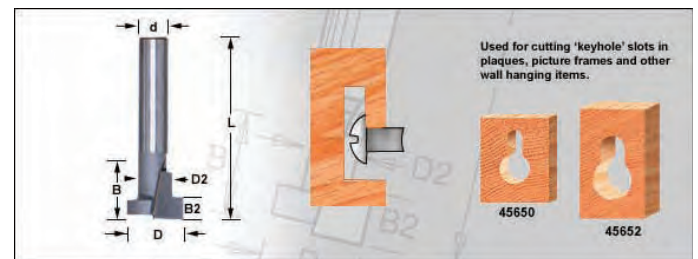

## Keyhole Bit

- Single Flute

Cat. #	Large Dia	Cutting Depth	Shank Dia	Overall Length
BTA45650	3/8	3/8	1/4	1-1/2
BTA45652	1/2	3/8	1/4	1-1/2

We stock Bosch bits as well and can cross reference bits for you.