

JILLIAN LAMP

- **Sculptural art in functional form.** A charcoal lava stone twist on our classic jillian showcases an undulating formation of asymmetrical discs. The porous surface delivers a subtle texture, especially when caught by an illuminated glow. Topped with an ivory microfiber shade and matching lava stone finial. Black cloth cord and antique brass hardware. Finish will vary.

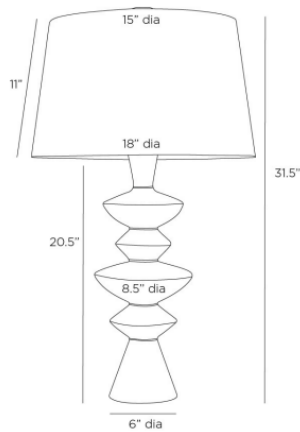

PRODUCT #:	ITEM	WIDTH	DEPTH	HEIGHT	PRICE	ADDITIONAL INFORMATION
254-PTC44-152	JILLIAN LAMP-CHARCOAL LAVA STONE	18	18	31.5	\$1,134	
254-49227-152	JILLIAN LAMP-WHITE GLASS STONE	18	18	32	\$1,170	

APPEARANCE

Material	Lava Stone, Microfiber, Steel
Finish	Antique Brass, Ivory
Finish Will Vary	true
Top Coat/Sealant	false
Finial Description	Charcoal lava stone to match
Finial Dimension	1.5" H x 2" Dia

DIMENSIONS

Shade	Top: 15.00 IN, Dia: 18.00 IN, Side: 11 IN
Body	H: 20.5 IN, Dia: 8.50 IN
Foot Print	Dia: 6.00 IN
Harp	9.5 IN

WIRING

Rating	Indoor Only
Tilt Test	10 Degrees - AU
Cord	8 FT, Back of Lamp Base, Black Cloth, SPT-2
Socket	1, Antique Brass, Type A - E26
Switch	3-Way Rotary, At Socket
Maximum Watt	150
Voltage	110-120 V

COMPLIANCY

RoHS	true
------	------

SHIPPING

Product Weight	23 LBS
Gross Weight 1	26 LBS
Gross Weight 2	5 LBS
Shipping Box 1	H: 27.2 IN, L: 11.4 IN, W: 11.4 IN
Shipping Box 2	H: 15 IN, L: 20 IN, W: 20 IN

ADDITIONAL INFO

Shade Shape	Round
Shade Trim	Rolled Edges
Shade Type	Hardback

REPLACEMENT PARTS

Replacement Part 1	PTC44FIN
Replacement Part 1 Dim	1.5"H x 2"Dia

CONTRACT

Contract Suitable	true
-------------------	------