

Analogue 24 hr Panel 16621 & 16622 (without battery reserve)



Benefits

A very simple to use and cost effective general purpose 24 hour timer, that is ideal for many applications. Each tappet around the analogue clock represents 10 minutes. An optional panel mount kit is available for when the back box provided is not suitable. The 16621 includes a 200 hour battery reserve, while the 16622 has no battery reserve.

Features

- Programming in steps of 10 minutes
- Minimum interval between 2 switchings: 20 minutes (two tappets)
- 72 switchings per day
- Switching accuracy: 1 minute 30 seconds
- Programming by captive segments. A red zone is uncovered when a tappet is moved to the ON status and is hidden when the tappet is moved to the OFF position.
- Time of day shown by hands, allowing time setting
- by simple rotation in either direction. Summer/Winter time corrections are made easily.
- Manual override with automatic return to program. Contact status display
- Terminals in housing which opens for easy wiring.
- Surface, Panel or Din rail mounting
- Voltage free 16A changeover contact
- Panel Mounting Options
- Fit using supplied back box - maximum panel thickness - 2mm (Connections made into back box)
- Fit using BR6 panel mounting kit - maximum panel thickness - 4mm (Connections made via tab terminals - back box discarded)

Technical Data

Supply voltage	230V + 10% -15%
Frequency	50/60 Hz
Power consumption	approx. 0.5 VA
Voltage free changeover contacts	16 (3) A
Changeover contacts	
resistive load	16 A 250 V
voltage free inductive load (cos = 0.6)	3 A 250 V
incandescent lamps	1000 W 250 V
squirrel-cage motor	350 W 250 V
Time base	Quartz
Accuracy of operation	1 sec / 24 h.
Operating temperature	-10°C to +50°C
Storage temperature	-20°C to +60°C
Connection by cage terminals, section of conductors	1 to 6 mm ²
Insulation class	II
Protection index IP 20	
Conformity to standard BS EN 60730	yes
Performance indicated for an ambient temperature of 20°C	

Electrical Connections

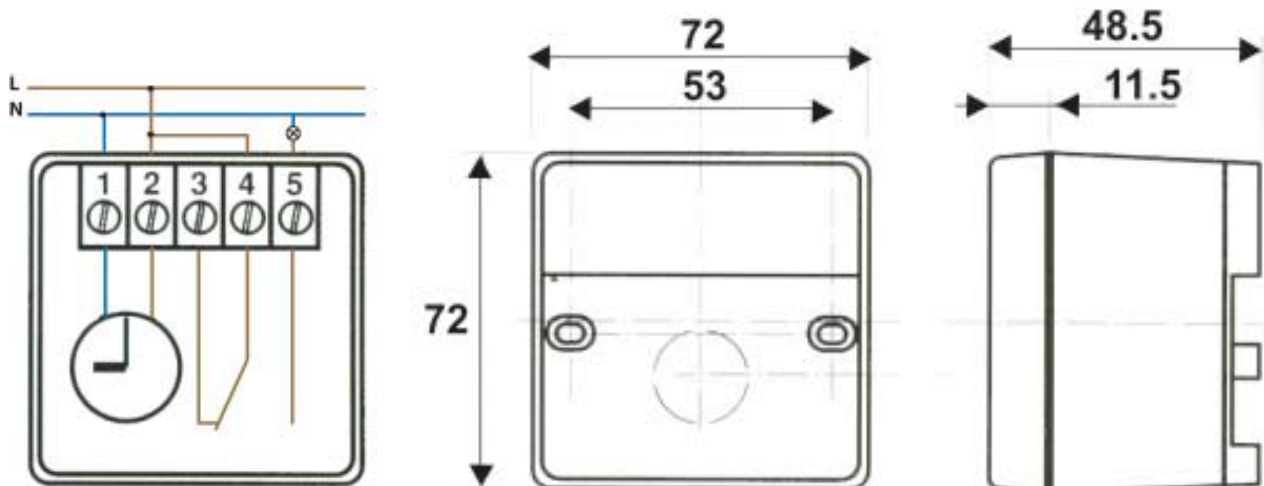

Contact Us: 01475 745131

CUSTOMER CARE POLICY

As part of Sangamo's continuous improvement program, the Company operates a Customer Care Policy. This means that we welcome your comments and complaints, as it can only help us to improve our services to you, our customer.

SANGAMO

Sangamo Limited, Industrial Estate, Port Glasgow,
Renfrewshire PA14 5XG

Tel: 01475 745131 Fax: 01475 744567

Email : enquiries@sangamo.co.uk Web: www.sangamo.co.uk