



Workbook
2021 / 2022

Ski + Snowboard



Trekking



Running



Cross Sports



Kids



Business Men



Business Women





Compression



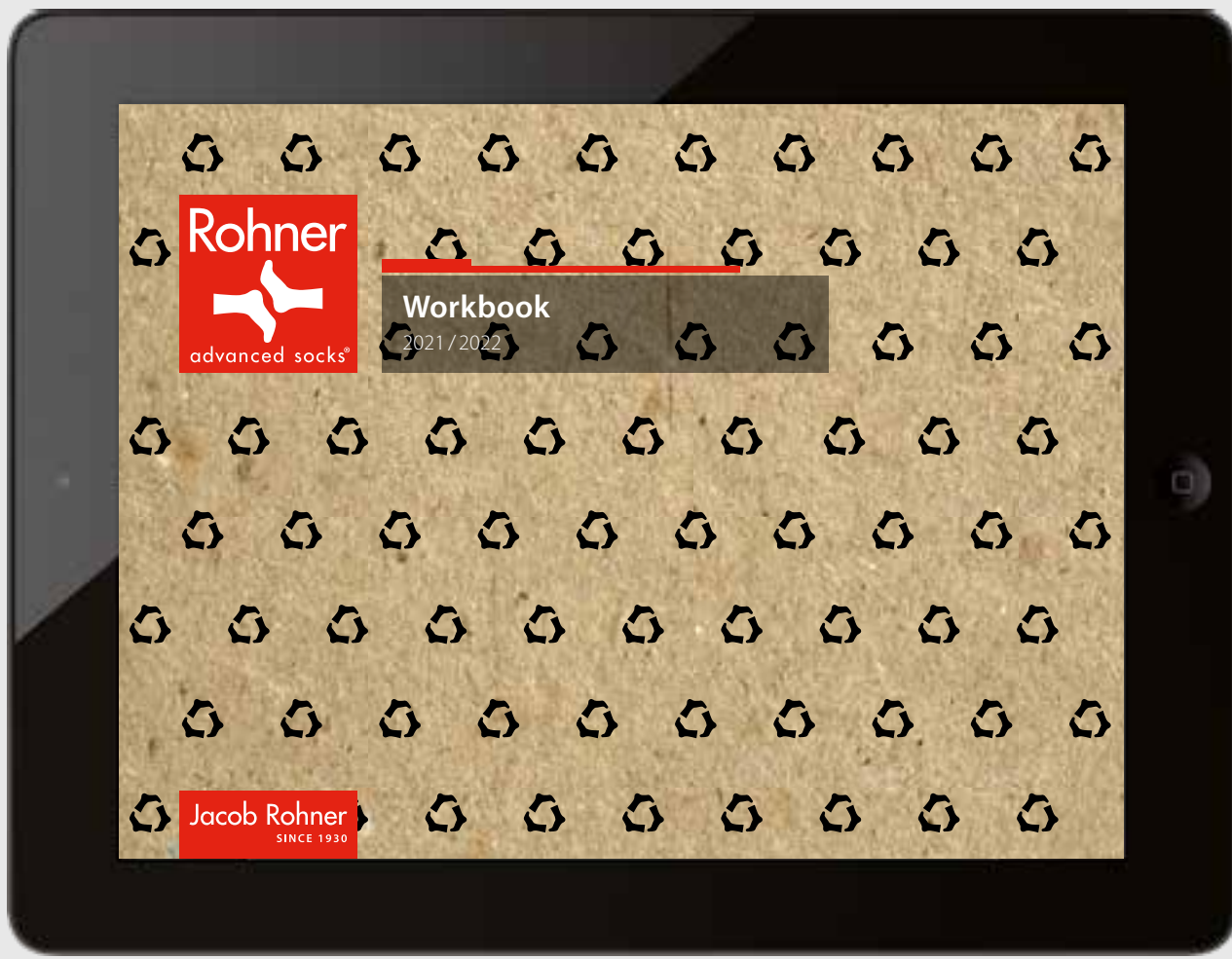

Health Care





 **Katalog:**
www.rohner-socks.com/marketing

 **Catalogue:**
www.rohner-socks.com/marketing

 **Catalog:**
www.rohner-socks.com/marketing

 **Catalogo:**
www.rohner-socks.com/marketing

KIDS

BUSINESS MEN

BUSINESS WOMEN

COMPRESSION

HEALTH CARE

SKI & SNOWBOARD

TREKKING

RUNNING

CROSS SPORTS



Swiss Heritage

+ 1930 gründete Jacob Rohner in Balgach eine Sockenfabrik; das Schweizer Rheintal war zu dieser Zeit berühmt für seine Textilfabrikationen. Mit der Anschaffung von Rundstrickmaschinen, welche erst kürzlich erfunden wurden gelang es Strümpfe und Socken von höchster Qualität zu produzieren. Die dazu benötigten Garne wurden ebenfalls in der Schweiz versponnen. Schon bald standen «Rohner-Socken» für höchste Qualität und Komfort.

Auch heute bleibt «Rohner» seinen Grundsätzen treu, dennoch werden die Strumpfwaren stets weiter entwickelt. Jeden Tag wird darüber nachgedacht die Produkte zu verbessern. Jeder Arbeitsschritt und jede Idee wird fortlaufend überdacht. Ziel bleibt höchster Tragekomfort, höchste Qualität und beste Passform.

Unsere Socken begleiten Sie im Alltag, auf Reisen und Expeditionen, sind Begleiter in jeder Situation. «Rohner Socken» prägen Ihren Fussabdruck immer wieder neu und so sind wir überzeugt Sie jeden Tag aufs Neue überraschen zu können.

+ When Jacob Rohner founded his sock company in the small town of Balgach in the Rhine Valley of Switzerland in 1930, he had a revolutionary idea in mind. He was looking to create a sock that would excel in performance, comfort, quality and design – the essential companion to the most demanding conditions and activities. Using a circular knitting machine, the finest natural materials and an attention to detail only the Swiss could perfect, Rohner broke the mold, exceeding all expectations of what a sock should be.

Today, Rohner's fundamental mission remains true, but our socks have evolved. Each day, we build on an already-perfect sock, innovating and discovering new technologies to take it to the next level. Every stitch has a reason, every fabric has a purpose. Because where we deliver unrivaled functionality, quality and design, you excel.

Our socks travel with our customers on life's most memorable adventures, expeditions, and everyday footprints.

We invite you to experience the world of Rohner and are proud to be a companion along every step of your life.

+ En 1930, Jacob Rohner avait une idée révolutionnaire lorsqu'il créa son entreprise de fabrication de chaussette dans la petite ville de Balgach situé dans la vallée du Rhin en Suisse. Il voulait produire une chaussette qui puisse être simultanément la meilleur en terme de qualité, confort et design. En soit, le meilleur companion pour supporter une multitudes d'activités lors de conditions d'utilisation normale à extrême. Rohner se démarqua en utilisant des machines à tricoter circulaire, les matériaux les plus nobles et un soin du détail que seul les Suisses ont pu perfectionner. **Ainsi, offrant des produits dépassant toutes attentes.**

Aujourd'hui la mission de Rohner reste inchangée, mais nos chaussettes ont évoluées. Chaque jour, nous découvrons de nouvelles technologies et créons de nouvelles innovations pour que nos produits reste au plus proche de la perfection.

Nos chaussettes voyagent avec nos clients dans leurs aventures et expéditions les plus mémorables, mais également pendant leurs activités quotidienne.

Nous vous invitons à expérimenter le monde de Rohner et sommes fière de vous accompagner à vos côtés, lors de chaque pas de votre vie.

Technology

🇩🇪 Rohner Advanced Socks arbeitet daran die innovativsten und bequemsten Socken zu entwickeln. Um dieses Ziel zu erreichen, verwenden wir die besten Materialien und unsere einzigartige Technologie.



Rohner Air Channel System R.A.C.S.

Feuchtigkeit wird mit Hilfe von High-Tech-Garnen (z.B. Coolmax®) in einen Puffer geleitet. Dieser Puffer aus einem Baumvoll- oder Wollplüsch nimmt die Feuchtigkeit auf und speichert sie. Dadurch, garantieren wir Ihnen mehr Komfort durch trockene Füße und trockenere Socken!



Rutschfestes Rohr

Diese speziell entwickelte und patentierte Rippkonstruktion zeichnet sich durch ihre konische Strickart aus. Das elastische Rohr garantiert einen perfekten Sitz, rutsch nicht und schneidet nicht ein.



Anatomical Left/Right socks

Socken mit dieser Technologie sind anatomisch optimiert und vermitteln einen höheren Trage-Komfort.



Nummerierten Socken

Durch diese Innovation, können Socken nach dem Waschen nicht mehr verwechselt werden. So können Sie immer die gleichen Socken zusammen tragen. Das gesamte Sortiment unserer Business Kollektion verfügt über diese einzigartige Eigenschaft.

🇩🇪 Rohner Advanced Socks focuses all its effort to create the most innovative and comfortable socks, to achieve this goal we implement the best materials available and we use our own developed and latest technologies:

Rohner Air Channel System R.A.C.S.

This system improves the dampness control. Indeed, dampness is drawn into the terry with the help of High Tech Yarns (i.e. Coolmax®). The puffers, which are made of cotton or woollen terry, collect and store very efficiently the dampness. In addition we guarantee more comfort through dry feet and dryer socks!

Non-slip ankle and joint support

This specially designed rib construction is characterised by its conical weave. The elastic ribbing guarantees perfect fit, does not slip and does not cut into the skin.

Anatomical Left/Right socks

Socks with this feature have an improved comfort; indeed they are anatomically optimised for the left and the right foot.

Numbered socks

Thanks to the number inscribed on the socks label, the socks can no longer be mixed up after the washing process. You can always keep the same pair of socks together! The entire assortment of our business collection has this unique feature.

🇫🇷 Rohner Advanced Socks concentre tous ses efforts pour créer les chaussettes les plus innovantes et confortables qui soient. Pour réussir ce pari, nous utilisons les meilleurs matériaux disponibles et utilisons nos technologies les plus récentes.

Rohner Air Channel System R.A.C.S.

Ce system permet d'améliorer le control de l'humidité. Les semelles en coton ou en laine permettent d'absorber l'humidité efficacement. Par la suite, cette même humidité est conduite vers l'extérieur de la semelle grâce à l'aide de fibres de haute technologies (ex. Coolmax®). Ainsi nous garantissons plus de confort et des pieds au sec!

Anti Slip Tube

Cette construction nervurée est caractérisée par sa forme conique. Elle permet un maintien parfait des chaussettes, sans glisser ni de couper à travers la peau.

Anatomie gauche/droit

Les chaussettes avec cette caractéristique on un confort amélioré, elles sont anatomiquement optimisé pour le pied gauche et droit.

Chaussettes numérotées

Grâce à cette innovation les chaussettes ne seront plus mélangés après le linge. Vous pouvez ainsi toujours porter les mêmes chaussettes ensemble. La gamme complète de notre collection «business» comprend cette propriété unique.



B2B-Shop

 **Sehr geehrte Rohner Kunden,**
Mit Stolz präsentieren wir Ihnen unseren neu implementierten B2B-Shop. Wir bieten Ihnen eine optimale Serviceleistung und Sie genießen die folgenden Vorteile:

- Bestellungen bequem und zeitsparend erfassen
- Verfügbarkeitsübersicht der gewünschten Artikel
- Einfache Auskunft der Einkaufs- und Verkaufspreise
- Überblick über den Bestellstatus und der Bestellhistorie

Bei Fragen oder Unklarheiten unterstützen Sie unsere freundlichen Verkaufsaussendienstmitarbeiter sowie Kundenberater gerne.

Um Ihr Einkaufserlebnis und unsere Kundenzufriedenheit stets verbessern zu können, danken wir Ihnen im Voraus für Ihr Feedback.

In diesem Sinne «Mach dich auf die Rohner Socken».
Ihr Jacob Rohner Team

b2b.rohner-socks.com

 **Dear Rohner customers,**
We are proud to present our new B2B-Shop to you. We offer you an optimal service and you will enjoy the following advantages:

- Enter orders conveniently and quickly
- Availability overview of your desired products
- Simple overview of purchase and selling prices
- Overview of order status and order history

If you have any questions or if anything is unclear, our friendly sales representatives and customer service will be glad to assist you.

In order to constantly improve your shopping experience and our customer satisfaction, we thank you in advance for your feedback.

And don't forget, «Rohner Socks are tops».
Your Jacob Rohner Team

b2b.rohner-socks.com

 **Chers clients Rohner,**
C'est Avec plaisir que nous vous présentons notre nouveau site B2B. Nous vous offrons un service optimal and vous pouvez profiter des avantages suivants:

- Vous pouvez saisir vos commandes en ligne et commander sur facture
- Vous avez directement accès à notre stock en temps réel
- Vous pouvez à tout moment consulter les prix d'achat et prix de vente conseillés
- Vous pouvez suivre votre commande et consulter votre historique d'achat

Nos équipes de ventes et d'après-vente sont disponibles pour de plus amples informations.

Afin/dans le but/dans l'optique de toujours améliorer notre service, nous sommes heureux de recevoir votre feedback.

b2b.rohner-socks.com



90 years Jacob Rohner AG

Schritt für Schritt

Als Jacob Rohner im Jahr 1930 im kleinen Dorf Balgach im Schweizer Rheintal seine Sockenfirma gründete, hatte er eine revolutionäre Idee im Sinn. Er wollte eine Socke kreieren, die sich durch ihre Leistung, ihren Komfort, ihre Qualität und ihr Design auszeichnen würde – der unverzichtbare Begleiter für die anspruchsvollsten Bedingungen und Aktivitäten. Unter Verwendung einer Rundstrickmaschine, der feinsten Naturmaterialien und mit einer Liebe zum Detail, die nur die Schweizer perfektionieren konnten, beschritt Rohner neue Wege und übertraf alle Erwartungen, was eine Socke sein sollte.

Wir sind stolz die Geschichte weiterschreiben und Ihnen die besten Socken anbieten zu können.

Step by step

When Jacob Rohner founded his sock company in the small town of Balgach in the Rhine Valley of Switzerland in 1930, he had a revolutionary idea in mind. He was looking to create a sock that would excel in performance, comfort, quality and design – the essential companion to the most demanding conditions and activities. Using a circular knitting machine, the finest natural materials and an attention to detail only the Swiss could perfect, Rohner broke the mold, exceeding all expectations of what a sock should be.

We are proud to pursue his quest 90 years later, and provide with the best socks.

Étape par étape

En 1930, Jacob Rohner avait une idée révolutionnaire lorsqu'il créa son entreprise de fabrication de chaussette dans le petit village de Balgach situé dans la vallée du Rhin en Suisse. Il voulait produire une chaussette qui puisse être simultanément le meilleur en termes de qualité, confort et design. En soit, le meilleur compagnon pour supporter une multitude d'activités lors de conditions d'utilisation normale à extrême. Rohner se démarqua en utilisant des machines à tricoter circulaire, les matériaux les plus nobles et un soin du détail que seul les Suisses ont pu perfectionner. Ainsi, offrant des produits dépassant toutes attentes.

Nous sommes fières de continuer cette aventure et de vous proposer les meilleures chaussettes.



Recycling

Ein Kreislaufsystem

Recover ermöglicht einen geschlossenen Kreis und eine wahrhaftig nachhaltige Modebranche: Textilien aus Rückgewinnungsfasern können für viele Lebenszyklen den Recyclingprozess durchlaufen. Es schafft in jeder nachfolgenden Generation langlebige, hochwertige Produkte.

Das Kreislaufsystem beläuft sich auf folgende Schritte:

1. Abfälle aus der Bekleidungsproduktion und gebrauchte Kleidungsstücke werden eingereicht: Alte Kleidungsstücke und Textilabfälle werden in Sammelbehältern zum erneuten Tragen oder Recycling deponiert. Recover sammelt und sortiert Textilabfälle aus aller Welt und recycelt es in neue Recover-Fasern.
2. Rückgewinnungsfasern werden zu neuen Garnen und Stoffen verarbeitet: Sie werden zu Garnen gesponnen und dann für praktisch jede denkbare Produktanwendung gestrickt oder zu neuen Textilien gewebt.
3. Neue Produkte werden aus Recover Stoffen hergestellt: Bekleidung, Accessoires, Haushalts- und Industrieprodukte werden aus Textilien von Recover-Fasern geschnitten und genäht.
4. Mit Recover hergestellte Produkte werden gekauft: Mode-, Accessoire- und Haushaltswaren werden gekauft, verwendet und schliesslich abgenutzt. Danach können sie wieder dem Recyclingprozess von Recover zugeführt werden.

Schliessung des Kreises in der Modebranche.

A circular system

Recover allows for a closed-loop and truly sustainable fashion industry: textiles made from Recover fiber can flow through the recycling process for many life cycles. Recover creates long-lasting, high-value products in each successive generation.

The circulation system consists of the following steps:

1. Used clothes and garment production waste is submitted: old garments and textile waste are deposited at collection bins for re-wear or recycling. Recover collects and sorts textile waste resources from all over the planet and recycles it into new Recover fiber.
2. Recover fibers are made into new yarns and fabrics: Recover fibers are spun into yarns and then knit or woven into new textiles for virtually every product application imaginable.
3. New products are made from Recover fabrics: apparel, accessories, home and industrial products are cut and sewn from textiles made with Recover fibre.
4. Products made with Recover are purchased: fashion, accessory and home goods are bought, used and eventually worn-out. Afterwards they can be returned to the Recover recycling process.

Closing the Loop on Fashion.

Un système circulaire

Recover permet une industrie circulaire de la mode et véritablement durable: les textiles fabriqués à partir des fibres Recover peuvent être réutilisés ensuite par le même processus de recyclage durant plusieurs cycles de vie du tissu. Recover crée des produits durables et à grande valeur ajouté.

Le système de circulation comprend les étapes suivantes:

1. Les vieux vêtements et les déchets textiles sont déposés dans des bacs de collecte pour être réutilisés ou recyclés. Recover collecte et trie ensuite les déchets textiles et les recycle en produisant une nouvelle fibre.
2. Les fibres de récupération sont effilochées puis transformées en nouveaux fils et tissus: les fibres récupérées sont par la suite filées, puis tricotées ou tissées afin de confectionner un nouveau textile.
3. De nouveaux produits sont fabriqués à partir de fibres Recover tels que: les vêtements, les accessoires, et les produits industriels.
4. Les produits fabriqués avec Recover reviennent sur le marché et entrent dans un nouveau cycle de consommation. En fin de vie, ils peuvent être une fois de plus recyclés en fibres.

Une mode circulaire.



Cupron

🇨🇭 Dieses Jahr haben wir unsere Forschung und Entwicklung auf ein spezielles und innovatives Garn eingesetzt. Cupron, ist eine Plattformtechnologie entwickelt durch die Beschichtung und Imprägnierung von einer Baumwoll-Polymermischung mit Kupferoxid (CuO).

Daraus resultieren Fasern, mit einem potentiell breiten Spektrum an antibakteriellen und antimykotischen Eigenschaften. Der Einsatz dieses Garnes in unseren Socken, mindert Geruchs- und Hautprobleme an Füßen. Studien haben eine Verbesserung oder ein Verschwinden der Hautrötung, der Fissuren, der Bläschenbildung, der Schuppen sowie des Brennens und Juckens belegt. Zuverlässig tötet es die meisten Pilze und auch geruchverursachende Bakterien ab, die bei langen Aktivitäten im Fussbereich entstehen.

Durch unsere optimale Verteilung des Garnes im Fussbereich, bringen wir eine neue Ski-Socke auf den Markt, bei welcher der Fuss-Komfort im Vordergrund steht und einen klaren Mehrwert für den Endverbraucher erzeugt.

🇨🇭 This year we have focused our effort in research and development towards an innovative and special yarn. Cupron is a technological platform developed through the combination of a cotton/polymer mixture with copper-oxide (CuO).

The result is a fibre with a large antibacterial and antifungal function. The use of such yarn in our socks, provides a reduction of odours and skin issues in the foot area. Studies have shown a reduction of skin redness, skin cracks, blister formation, scales and overall irritation.

It also kills and reduces the number of fungus in the foot area, that are developing during long sport sessions.

Through effective distribution of the yarn in the foot area, we bring to the market a new Ski-Sock, in which the comfort of feet is our priority.

🇫🇷 Cette année, nous avons concentré nos efforts en recherche et développement sur un fil novateur et spécial. Cupron est une plate-forme technologique développée par la combinaison d'un mélange coton / polymère et d'oxyde de cuivre (CuO).

Le résultat est une fibre avec une fonction antibactérienne et antifongique importante. L'utilisation de ce fil dans nos chaussettes permet de réduire les odeurs et les problèmes de peau dans la région des pieds. Des études ont montré une amélioration des rougeurs cutanées, des crevasses cutanées, de la formation de cloques, et la réduction d'une irritation générale. Celui-ci réduit le nombre de mycoses et de bactéries dans la région du pied, qui peuvent notamment se développer chez un athlète.

Grâce à une distribution efficace du fil dans la zone des pieds, nous commercialisons une nouvelle chaussette de ski dans laquelle le confort des pieds est notre priorité.

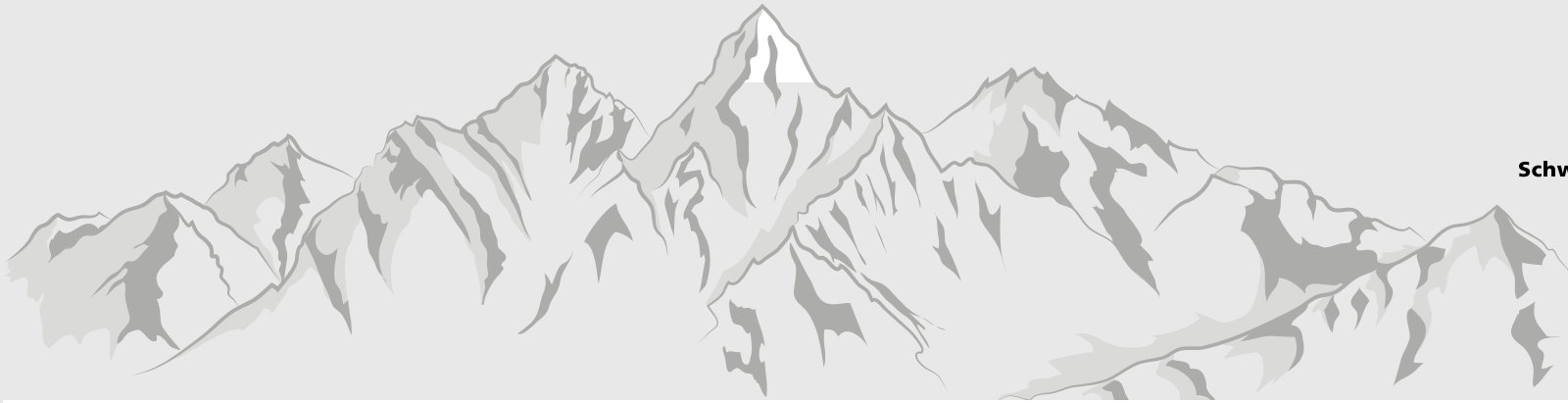

Schweizer Alpen-Club SAC
Club Alpin Suisse
Club Alpino Svizzero
Club Alpin Svizzer



Our cooperation with SAC

Die Kooperation zwischen Jacob Rohner AG und SAC

Die Jacob Rohner AG stellt seit 1930 hochwertige Socken für diverse Sportarten her und hat nun zusammen mit dem SAC eine besondere Trekkingsocke auf den Markt gebracht.

Mit rund 150'000 Mitgliedern ist der Schweizer Alpen-Club SAC einer der grössten Sportverbände der Schweiz.

Seit der Gründung 1863 ist der SAC eine mitgestaltende Kraft, bei der Entwicklung des Alpenraums und des Alpinismus. Aus dieser Tradition heraus, setzt er sich heutzutage für verantwortungsvollen Bergsport und weitgehend freien Zugang zur Bergwelt ein.

Durch diese einzigartige Kooperation unterstützt die Jacob Rohner AG ein vielfältiges, attraktives Ausbildungsprogramm für die SAC-Jugend.

Weitere Informationen finden Sie unter:
rohner-socks.com/brand/sac

The cooperation between Jacob Rohner AG and SAC

Since 1930, the Jacob Rohner AG has been producing high-quality socks for various sports and has now launched special trekking socks together with the SAC.

With around 150,000 members, the Swiss Alpine Club SAC is one of the largest sport association in Switzerland.

Since its foundation in 1863, the SAC has been a co-shaping force for the development of alpine regions and alpinism. Thanks to this tradition, the SAC allows today to practice responsible mountain sports and guarantees an extensive access to the mountains.

Through this unique cooperation, the Jacob Rohner AG supports a diverse, attractive training program for the SAC youth.

More information at:
rohner-socks.com/brand/sac

La coopération entre Jacob Rohner AG et le CAS

La Jacob Rohner AG offre depuis 1930 des chaussettes de hautes qualités pour différents sports et a maintenant conçu une chaussette de randonnée spéciale avec le CAS.

Avec environs 150.000 membres le Club Alpin Suisse est l'une des plus grandes associations sportives en Suisse.

Depuis sa fondation en 1863, le CAS est l'une des forces principales pour le développement des régions alpines et l'alpinisme. À travers cette tradition, le CAS permet de pratiquer aujourd'hui des sports de montagne responsables et garanti un accès étendu aux montagnes.

Grâce à cette collaboration unique, la Jacob Rohner AG soutient un programme de formation diversifié et attrayant pour les jeunes membres du SAC.

Plus d'informations sur:
rohner-socks.com/brand/sac

Ski + Snowboard

warm und trocken durch den Schnee



NEW eco jet
70.257/3

comfort plus

Cushion/Volume:



Season:



over the calf

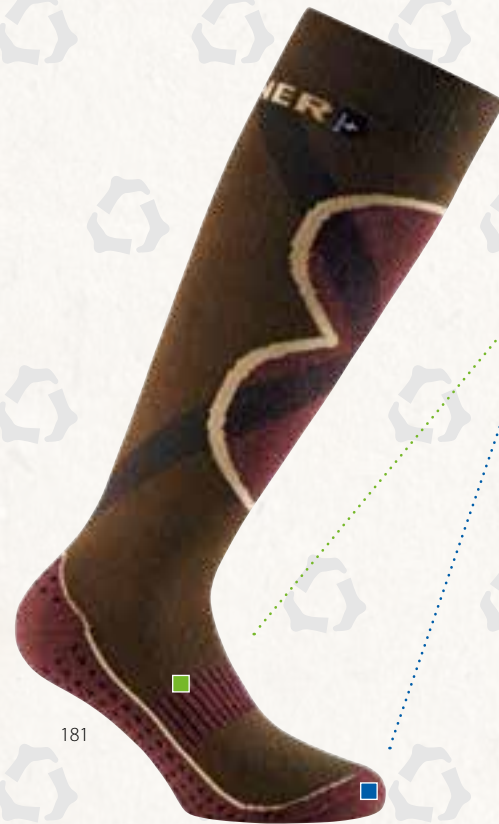

Besonderheiten:

- Elastzone für optimalen Halt
- Gekettelt

Hauptvorteil:

- Maximale Polsterung und Wärme
- Nachhaltiges Produkt

Entwickelt für:

- Maximaler Komfort

Sport / Verwendung:

- Allmountain

Eigenschaften:

- Aus recycelten Materialien
- Schienbeinschutz
- Vollplüschsocke
- Weicher Abschlussrand

Specificities:

- Elastic zone for improved support
- Seamless

Main Benefit:

- Maximum cushioning and warmth
- Sustainable product

Designed For:

- Maximum comfort

Sports / Use:

- Allmountain

Features:

- Made from recycled material
- Shinbone protection
- Full terry construction
- Soft border

Particularités:

- Zone élastique pour un meilleur maintien
- Remmaillée

Principal avantage:

- Rembourrage et chaleur maximale
- Produit durable

Conçue pour:

- Confort maximale

Sports / Utilisations:

- Tous les sports et activités de montagne

Caractéristiques:

- A partir de matériaux recyclés
- Protection du tibia
- Construction pleine peluche
- Bord souple

Particolarità:

- Zona elastica per un supporto migliorato
- Punta rimagliata

Vantaggio principale:

- Massimo ammortizzamento e mantenimento del calore
- Prodotto sostenibile

Progettato per:

- Massimo comfort per il piede

Sport / Uso:

- Tutti le pratiche alpinistiche

Caratteristiche:

- Realizzato con materiale riciclato
- Protezione dello stinco
- Struttura interamente in spugna
- Bordo morbido

181

41% Polyester (recyclt)
32% Wolle (recyclt)
17% Polyamid (recyclt)
9% Polyamid
1% Elasthan



Rohner	Europe	US Men's	US Women
S	36 - 38	3 - 5 1/2	4 1/2 - 6 1/2
M	39 - 41	6 - 8	7 1/2 - 9 1/2
L	42 - 44	8 1/2 - 10	10 - 11 1/2
XL	44 - 46	10 - 12	11+
XXL	47 - 48	13 - 15	

touring light

70.244/3

perfect fit



009



Besonderheiten:

- Luftkanäle
- Elastzone für optimalen Halt
- Spitze und Ferse mit Profilen®
- Gekettelt



Specificities:

- Air channels
- Elastic zone for optimal support
- Toe and heel area in Profilen®
- Seamless



Particularités:

- Canaux d'aération
- Zone élastique pour un maintien optimale
- Pointes et talons hauts Profilen®
- Remmaillée



Particolarità:

- Canali per il passaggio dell'aria
- Zona elastica per un supporto ottimale
- Punta e parte alta del tallone con Profilen®
- Punta rimagliata

Cushion/Volume:



Season:



over the calf



Hauptvorteil:

- Feuchtigkeitsregulierung und Langlebigkeit

Main Benefit:

- Moisture management and durability

Principal avantage:

- Gestion de l'humidité et durabilité

Vantaggio principale:

- Gestione dell'umidità e resistenza

Entwickelt für:

- Touring

Designed For:

- Touring

Conçue pour:

- Randonnée

Progettato per:

- Touring

Sport / Verwendung:

- Touring
- Schneeschuhe

Sports / Use:

- Touring
- Snowshoe

Sports / Utilisations:

- Randonnée
- Raquette à neige

Sport / Uso:

- Touring
- Racchette da neve

Eigenschaften:

- Polsterung im Fussbereich
- Feuchtigkeitsregulierung
- Abriebfestigkeit
- Pique-Struktur

Features:

- Terry construction in foot area
- Moisture management
- Wear resistance
- Pique structure

Caractéristiques:

- Construction en peluche dans la zone du pied
- Gestion de l'humidité
- Résistance
- Structure de piqué

Caratteristiche:

- Struttura in spugna nell'area del piede
- Gestione dell'umidità
- Resistenza all'usura
- Struttura piqué

35% Polyacryl
 23% Schurwolle / new wool
 18% PTFE (Profilen®)
 16% Polypropylen
 6% Polyamid
 2% Elasthan (Lycra®)



561



SAC touring light

70.244/6



Rohner	Europe	US Men's	US Women
S	36 - 38	3 - 5 1/2	4 1/2 - 6 1/2
M	39 - 41	6 - 8	7 1/2 - 9 1/2
L	42 - 44	8 1/2 - 10	10 - 11 1/2
XL	44 - 46	10 - 12	11+
XXL	47 - 48	13 - 15	-

nordic light

70.244/1

cross-country

Cushion/Volume:



Season:



crew cut



009



Besonderheiten:

- Luftkanäle
- Elastzone für optimalen Halt
- Spitze und Ferse mit Profilen®
- Gekettelt



Specificities:

- Air channels
- Elastic zone for optimal support
- Toe and heel area in Profilen®
- Seamless



Particularités:

- Canaux d'aération
- Zone élastique pour un maintien optimale
- Pointes et talons hauts Profilen®
- Remmaillée



Particolarità:

- Canali per il passaggio dell'aria
- Zona elastica per un supporto ottimale
- Punta e parte alta del tallone con Profilen®
- Punta rimagliata

Hauptvorteil:

- Feuchtigkeitsregulierung und Langlebigkeit

Entwickelt für:

- Nordic

Sport / Verwendung:

- Langlauf
- Eislauf
- Skating
- Allsport

Eigenschaften:

- Schienbeinschutz
- Temperaturkontrolle

Main Benefit:

- Moisture management and durability

Designed For:

- Nordic

Sports / Use:

- Cross-country skiing
- Ice skating
- Skating
- Allsport

Features:

- Shinbone protection
- Thermo control

Principal advantage:

- Gestion de l'humidité et durabilité

Conçue pour:

- Ski nordique

Sports / Utilisations:

- Ski nordic
- Patinage
- Skating
- Allsport

Caractéristiques:

- Protection du tibia
- Régulation thermique

Vantaggio principale:

- Gestione dell'umidità e resistenza

Progettato per:

- Sci nordico

Sport / Uso:

- Sci nordico
- Pattinaggio
- Skating
- Allsport

Caratteristiche:

- Protezione dello stinco
- Termoregolante

35% Polyacryl
23% Schurwolle / new wool
18% PTFE (Profilen®)
16% Polypropylen
6% Polyamid
2% Elasthan (Lycra®)



Rohner	Europe	US Men's	US Women
S	36 - 38	3 - 5 1/2	4 1/2 - 6 1/2
M	39 - 41	6 - 8	7 1/2 - 9 1/2
L	42 - 44	8 1/2 - 10	10 - 11 1/2
XL	44 - 46	10 - 12	11+
XXL	47 - 48	13 - 15	-

nordic power l/r allsport

72.111/2 *Solange Vorrat*

thermo control

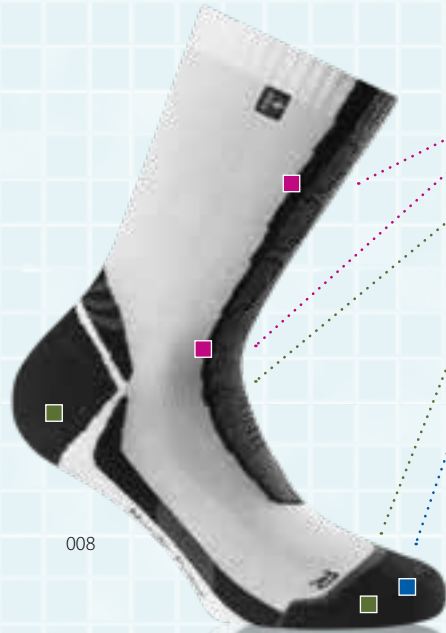

008



401

- Besonderheiten:**
- Leichte Polsterung im Schienbein und Ristbereich
 - Spitze und Ferse mit Profilen® (Blister Free)
 - Gekettelt

- Hauptvorteil:**
- Verbesserte Durchblutung
 - Entspannung der Muskulatur
 - Verbesserte Regenerationsfähigkeit
 - Entsäuerung der Muskulatur

- Entwickelt für:**
- Nordic

- Sport / Verwendung:**
- Langlauf
 - Eislauf
 - Skating
 - Allsport

- Eigenschaften:**
- Schienbeinschutz
 - Temperaturkontrolle
 - Polsterung im Fuss- und Ristbereich

- Specificities:**
- Light cushioning in shinbone and instep area
 - Toe and heel area with Profilen® (Blister Free)
 - Seamless

- Main Benefit:**
- Improved circulation
 - Relaxing muscles
 - Improved ability to regenerate
 - Acidification of the muscles

- Designed For:**
- Nordic

- Sports / Use:**
- Cross-country skiing
 - Ice skating
 - Skating
 - Allsport

- Features:**
- Shinbone protection
 - Thermo control
 - Terry construction in foot- and instep area

- Particularités:**
- Rembourrage léger au niveau de la zone du tibia et le cou-de-pied
 - Pointes et talons hauts Profilen® (Blister Free)
 - Remmaillée

- Principal avantage:**
- Amélioration de la circulation du sang
 - Relaxation de la musculature
 - Amélioration de la capacité de régénération
 - Désacidification de la musculature

- Conçue pour:**
- Ski nordique

- Sports / Utilisations:**
- Ski nordic
 - Patinage
 - Skating
 - Allsport

- Caractéristiques:**
- Protection du tibia
 - Régulation thermique
 - Construction en peluche dans la zone du pied et de cou-de pied

- Particolarità:**
- Imbottitura leggera nell'area dello stinco e nell'area del collo del piede
 - Punta e parte alta del tallone con Profilen® (Blister Free)
 - Punta rimagliata

- Vantaggio principale:**
- Miglioramento della circolazione del sangue
 - Rilassamento della muscolatura
 - Maggiore capacità di rigenerazione muscolare
 - Disacidificazione dei muscoli

- Progettato per:**
- Sci nordico

- Sport / Uso:**
- Sci nordico
 - Pattinaggio
 - Skating
 - Allsport

- Caratteristiche:**
- Protezione dello stinco
 - Termoregolante
 - Spugna nel plantare e sul collo del piede

36% Polyester Biokeramik / Bioceramic
 21% Polyamid
 19% Polyacryl
 18% Wolle / Wool
 4% Profilen
 2% Elasthan



Rohner	Europe	US Men's	US Women
S	36 - 38	3 - 5 1/2	4 1/2 - 6 1/2
M	39 - 41	6 - 8	7 1/2 - 9 1/2
L	42 - 44	8 1/2 - 10	10 - 11 1/2
XL	44 - 46	10 - 12	11+

ultra light

70.082/3

compact fit

Cushion/Volume:



Season:



over the calf



009

**Besonderheiten:**

- Speziell entwickelte Polsterung
- Elastzone für besseren Halt im Rist- und Fesselbereich
- Verstärkte Hochferse
- Ballenverstärkung
- Gekettelt

**Specificities:**

- Specially developed padding
- Elastic zone for improved support around the instep and ankle
- Strengthened high-heel
- Ball of the foot reinforcement
- Seamless

**Particularités:**

- Rembourrage spécialement élaboré
- Zone élastique pour un meilleur maintien au niveau du cou-de-pied et de l'avant pied
- Haut du talon renforcé
- Voûte plantaire renforcée
- Remmaillée

**Particolarità:**

- Rivestimento appositamente studiato
- Zona elastica per un supporto migliorato attorno al collo del piede e alla caviglia
- Tallone rinforzato di altezza maggiorata
- Estremità del metatarso rinforzate
- Punta rimagliata

Hauptvorteil:

- Leicht und direkter Schuhkontakt

Entwickelt für:

- Kraftübertragung

Sport / Verwendung:

- Racing
- Performance

Eigenschaften:

- Schienbeinschutz
- Polsterung im Fussbereich
- Feuchtigkeitsregulierung
- Pique-Struktur

Main Benefit:

- Light and close shoe contact

Designed For:

- Power transmission

Sports / Use:

- Racing
- Performance

Features:

- Shinbone protection
- Terry construction in foot area
- Moisture management
- Pique structure

Principal advantage:

- Légèreté et parfait contact avec la chaussure

Conçue pour:

- Transfert d'énergie

Sports / Utilisations:

- Prestations de haut niveau

Caractéristiques:

- Protection du tibia
- Construction en peluche dans la zone du pied
- Gestion de l'humidité
- Structure de piqué

Vantaggio principale:

- Massima leggerezza e sensibilità alla calzatura

Progettato per:

- Trasmissione della potenza

Sport / Uso:

- Competizioni
- Alte prestazioni

Caratteristiche:

- Protezione dello stinco
- Struttura in spugna nell'area del piede
- Gestione dell'umidità
- Struttura piqué



042**

076**

50% Schurwolle/new wool
35% Polyamid
14% Polypropylen
1% Elasthan (Lycra®)



schoeller
the spinning group

Rohner	Europe	US Men's	US Women
S	36 - 38	3 - 5 1/2	4 1/2 - 6 1/2
M	39 - 41	6 - 8	7 1/2 - 9 1/2
L	42 - 44	8 1/2 - 10	10 - 11 1/2
XL	44 - 46	10 - 12	11+

** – solange Vorrat

race light

70.225/3 *Limited Edition*

power transmission

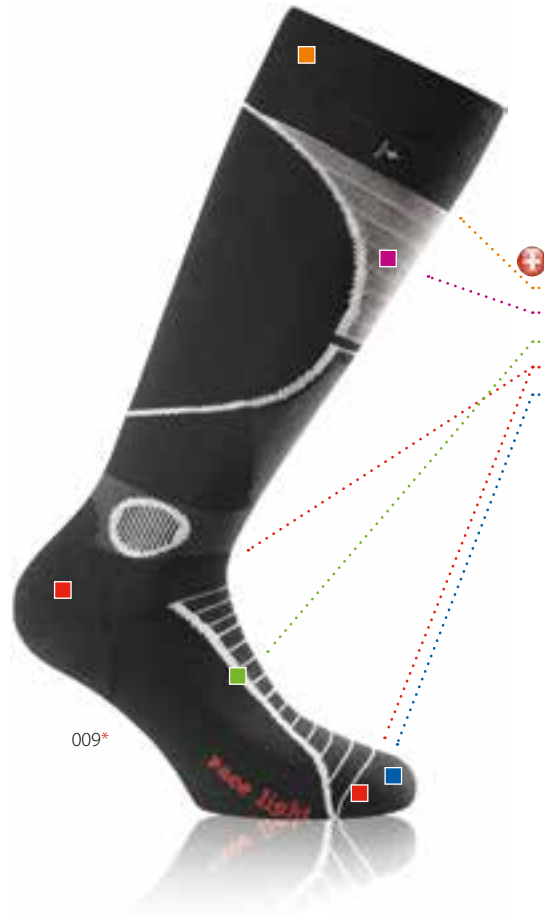

009*

Besonderheiten:

- Weicher Abschlussrand
- Leichte Polsterung im Schienbeinbereich
- Elastzone im Fussbereich
- Lenofilverstärkung im Fersen- und Zehenbereich
- Gekettelt

Specificities:

- Soft border
- Light cushioning in shinbone area
- Elastic zone in foot area
- Reinforcement in heel and toe with Lenofil
- Seamless

Particularités:

- Bords non comprimants
- Rembourrage léger au niveau de la zone du tibia
- Renforcement élastique dans la zone du pied
- Talon et orteils renforcés avec Lenofil
- Remmaillée

Particolarità:

- Bordo in tessuto morbido
- Imbottitura leggera nell'area dello stinco
- Zona elastica nell'area del piede
- Punta e tallone rinforzati con Lenofil
- Punta rimagliata

Hauptvorteil:

- Feuchtigkeitsregulierung
- Leicht und dünn

Entwickelt für:

- Optimale Kraftübertragung
- Direkten Schuhkontakt

Sport / Verwendung:

- Profisport

Eigenschaften:

- Leichte Polsterung im Schienbeinbereich
- Elastzone im Fussbereich
- Piquet-Struktur im Ristbereich
- Lenofilverstärkung im Fersen- und Zehenbereich
- Weicher Abschlussrand

Main Benefit:

- Moisture management
- Light and thin

Designed For:

- Optimal power transmission
- Close shoe contact

Sports / Use:

- Professional sport

Features:

- Light cushioning in shinbone area
- Elastic zone in foot area
- Pique structure in instep area
- Reinforcement in heel and toe with Lenofil
- Soft border
- Seamless

Principal avantage:

- Gestion de l'humidité
- Légèreté et finesse

Conçue pour:

- Transfert d'énergie optimal
- Contact étroit avec la chaussure

Sports / Utilisations:

- Sport professionnel

Caractéristiques:

- Rembourrage léger au niveau de la zone du tibia
- Zone élastique au niveau du pied
- Structure de piqué sur le cou-de-pied
- Talon et orteils renforcés avec Lenofil
- Bords non comprimants
- Remmaillée à la main

Vantaggio principale:

- Gestione dell'umidità
- Le Leggero e sottile

Progettato per:

- Trasmissione ottimale della potenza
- Massima aderenza alla calzatura

Sport / Uso:

- Sciatori professionisti

Caratteristiche:

- Imbottitura leggera nell'area dello stinco
- Zona elastica nell'area del piede
- Struttura piquet sul collo del piede
- Punta e tallone rinforzati con Lenofil
- Bordo in tessuto morbido
- Rimagliato a mano

35% Wolle (Merino) / Wool (Merino)
 23% Polypropylen
 18% Polyamid (Meryl Skinlife®)
 11% Polyamid
 11% PTFE (Profilen®)
 2% Elasthan (Lycra®)



Rohrer	Europe	US Men's	US Women
S	36 - 38	3 - 5 1/2	4 1/2 - 6 1/2
M	39 - 41	6 - 8	7 1/2 - 9 1/2
L	42 - 44	8 1/2 - 10	10 - 11 1/2
XL	44 - 46	10 - 12	11+
XXL	47 - 48	13 - 15	-

high performance l/r

70.178/3

dry feet



Cushion/Volume:



Season:



over the calf

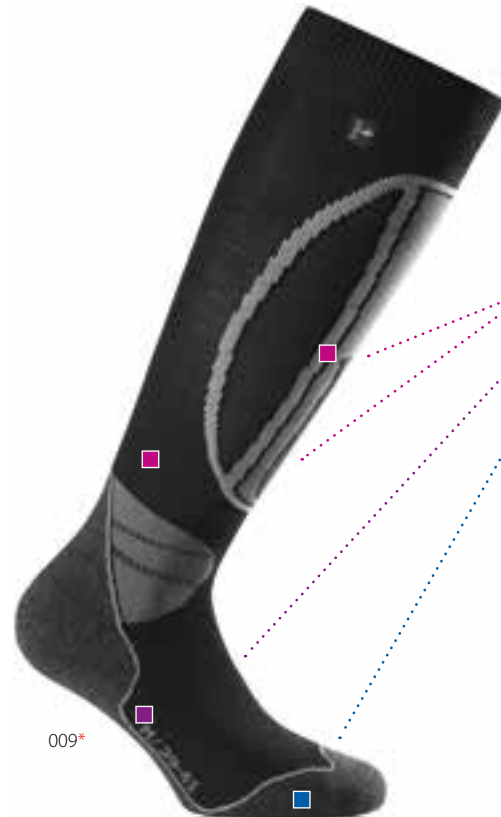

009*



329

114



Besonderheiten:

- Speziell entwickelte Polsterung für Schienbein und Hochferse
- Anatomische Polsterung im Knöchel- und Fussbereich
- Gekettelt



Specificities:

- Specially developed padding for the shinbone and the upper heel
- Anatomical padding in ankle and foot area
- Seamless



Particularités:

- Rembourrage spécialement conçu pour le tibia et le talon haut
- Rembourrage anatomique au niveau de la cheville et du pied
- Remmaillée



Particolarità:

- Imbottitura espressamente studiata per lo stinco e la parte superiore del tallone
- Imbottitura anatomica nella caviglia e nel piede
- Punta rimagliata

Hauptvorteil:

- Feuchtigkeitsregulierung und selektive Polsterung

Entwickelt für:

- Trockene Füße
- Kraftübertragung

Sport / Verwendung:

- Performance
- Freeride

Eigenschaften:

- Antibakteriell
- Geruchshemmend
- Antistatisch
- Schienbeinschutz
- Knöchelschutz
- Polsterung im Fussbereich
- Feuchtigkeitsregulierung
- Anatomische Passform
- Weicher Abschlussrand

Main Benefit:

- Moisture management and selective cushioning

Designed For:

- Dry feet
- Power transmission

Sports / Use:

- Performance
- Freeride

Features:

- Antibacterial
- Anti-odor
- Antistatic
- Shinbone protection
- Ankle protection
- Terry construction in foot area
- Moisture management
- Anatomical fit
- Soft border

Principal avantage:

- Gestion de l'humidité et rembourrage sélectif

Conçue pour:

- Pieds secs
- Transfert d'énergie

Sports / Utilisations:

- Prestations de haut niveau
- Surf des neiges

Caractéristiques:

- Antibactérienne
- Anti-odeur
- Antistatique
- Protection du tibia
- Protection de la cheville
- Construction en peluche dans la zone du pied
- Gestion de l'humidité
- Forme anatomique
- Bord souple

Vantaggio principale:

- Gestione dell'umidità e ammortamento selettivo

Progettato per:

- Asciuttezza del piede
- Trasmissione della potenza

Sport / Uso:

- Alte prestazioni
- Freeride

Caratteristiche:

- Antibatterico
- Antiodore
- Antistatico
- Protezione dello stinco
- Protezione della caviglia
- Struttura in spugna nell'area del piede
- Gestione dell'umidità
- Calzata anatomica
- Bordo morbido

35% Wolle (Merino) / Wool (Merino)
33% Polyamid
17% Polyacryl
14% Polypropylen
1% Elasthan (Lycra®)

fresh CLIMAYARN®
Combines nature and high-performance



schoeller
the spinning group

Rohner	Europe	US Men's	US Women
S	36 - 38	3 - 5 1/2	4 1/2 - 6 1/2
M	39 - 41	6 - 8	7 1/2 - 9 1/2
L	42 - 44	8 1/2 - 10	10 - 11 1/2
XL	44 - 46	10 - 12	11+
XXL*	47 - 48	13 - 15	

XXL* – nur / only / seulment / solo col. 009

SAC copper Jet

70.236/6 *Limited Edition*

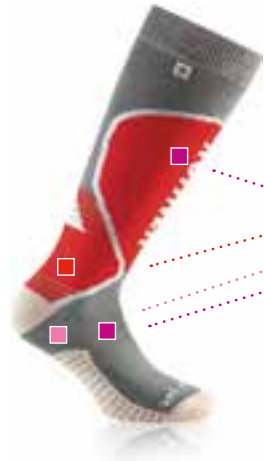

058*

- Besonderheiten:**
- Verstärkte Hochferse
 - Plüsch im Fussbereich
 - Rist- und Schienbeinpolsterung

- Specificities:**
- Reinforced high-heel
 - Terry construction in foot area
 - Instep and shinbone cushioning

- Particularités:**
- Haut du talon renforcé
 - Peluche dans la zone du pied
 - Rembourrage cou-de-pied élastique

- Particolarità:**
- Tallone rinforzato
 - Interno in tessuto felpato nella zona del piede
 - Imbottitura nella zona dello stinco e del collo del piede



copper Jet

70.236/3

- Hauptvorteil:**
- Mildert Hautprobleme an Füßen (Anti-Fusspilz)
 - Maximaler Fusskomfort

- Main Benefit:**
- Attenuates the skin problems of the feet (antifungal)
 - Maximum comfort for the feet

- Principal avantage:**
- Atténue les problèmes de peau des pieds (antifongique)
 - Comfort maximum des pieds

- Vantaggio principale:**
- Attenua i problemi per pelli delicate (anti-fungine)
 - Massimo conforto del piede

- Entwickelt für:**
- Hautprobleme an Füßen
 - Trockene Füße

- Designed For:**
- Skin problems on the feet
 - Dry feet

- Conçue pour:**
- Problèmes de peau aux pieds
 - Pieds secs

- Progettato per:**
- Problemi di pelle ai piedi
 - Piedi con pelle disidratata

- Sport / Verwendung:**
- Allmountain

- Sports / Use:**
- Allmountain

- Sports / Utilisations:**
- Allmountain

- Sport / Uso:**
- Sport su neve

- Eigenschaften:**
- Antibakteriell
 - Antimykotisch
 - Geruchshemmend
 - Hautfreundlich
 - Mildert Hautrötungen, Fissuren, Bläschenbildung, Schuppen, Juckreiz
 - Flachnaht

- Features:**
- Antibacterial
 - Antifungal
 - Anti-odor
 - Gentle for the skin
 - Reduces redness, cracks, blisters, dandruff, burns and itching of the skin
 - Flat seam

- Caractéristiques:**
- Antibactérienne
 - Antifongique
 - Anti-odeur
 - Doux pour la peau
 - Atténue les rougeurs, les crevasses, les cloques, les pellicules et les démangeaisons de la peau
 - Couture plate

- Caratteristiche:**
- Antibatterico
 - Antimicotico
 - Antiodore
 - Delicato sulla pelle
 - Attenua gli arrossamenti, le screpolature, la formazione di vesciche, la desquamazione e il prurito
 - Cucitura piatta

29% Schurwolle / new wool
 29% Polyacryl
 24% Cupron (12% Kupfer-Polyester / Copper-Polyester, 12% Baumwolle / Cotton)
 17% Polyamid
 1% Elasthan



014***



059*



561***



Rohner	Europe	US Men's	US Women
S	36 - 38	3 - 5 1/2	4 1/2 - 6 1/2
M	39 - 41	6 - 8	7 1/2 - 9 1/2
L	42 - 44	8 1/2 - 10	10 - 11 1/2
XL	44 - 46	10 - 12	11+
XXL*	47 - 48	12 1/2 - 13	

* - nur / only / seulement / solo col. 058 + 059
 *** - Limited Edition

carving l/r

72.008/3

climate control

NEU
NOUVEAU
NUOVOL-R
Anatomical

Cushion/Volume:



Season:



over the calf

**Besonderheiten:**

- Speziell entwickelte Polsterung für Schienbein und Hochferse
- Lüftungskanäle im Fußbereich
- Anatomische Polsterung im Knöchel- und Fußbereich
- Gekettelt

Specificities:

- Specially developed padding for the shinbone and the upper heel
- Ventilation channels in the foot area
- Anatomical padding in ankle and foot area
- Seamless

Particularités:

- Rembourrage spécialement conçu pour le tibia et le talon haut
- Canaux d'aération au niveau du pied
- Rembourrage anatomique au niveau de la cheville et du pied
- Remmaillée

Particolarità:

- Imbottitura espressamente studiata per lo stinco e la parte superiore del tallone
- Canali di ventilazione nel piede
- Imbottitura anatomica nella caviglia e nel piede
- Punta rimagliata

Hauptvorteil:

- Temperaturkontrolle und selektive Polsterung

Main Benefit:

- Thermo control and selective cushioning

Principal avantage:

- Régulation thermique et rembourrage sélectif

Vantaggio principale:

- Tessuto termoregolante e ammortizzamento selettivo

Entwickelt für:

- Wärme- und Kraftübertragung

Designed For:

- Warmth and power transmission

Conçue pour:

- Transfert de chaleur et d'énergie

Progettato per:

- Mantenimento del calore e trasmissione della potenza

Sport / Verwendung:

- Performance
- Freeride

Sports / Use:

- Performance
- Freeride

Sports / Utilisations:

- Prestations de haut niveau
- Freeride

Sport / Uso:

- Alta prestazione
- Freeriding

Eigenschaften:

- Antibakteriell
- Geruchshemmend
- Antistatisch
- Schienbeinschutz
- Knöchelschutz
- Polsterung im Fußbereich
- Temperaturkontrolle
- Anatomische Passform

Features:

- Antibacterial
- Anti-odor
- Antistatic
- Shinbone protection
- Ankle protection
- Terry construction in foot area
- Thermo control
- Anatomical fit

Caractéristiques:

- Antibactérienne
- Anti-odeur
- Antistatique
- Protection du tibia
- Protection de la cheville
- Construction en peluche dans la zone du pied
- Régulation thermique
- Forme anatomique

Caratteristiche:

- Antibatterico
- Antiodore
- Antistatico
- Protezione dello stinco
- Protezione della caviglia
- Struttura in spugna nell'area del piede
- Tessuto termoregolante
- Calzata anatomica

44% Polyacryl (Outlast*)
21% Polyamid
19% Polyacryl
15% Schurwolle / new wool
1% Elasthan (Lycra®)



schoeller
the spinning group

fresh

Rohner	Europe	US Men's
S*	36 - 38	3 - 5 1/2
M*	39 - 41	6 - 8
L	42 - 44	8 1/2 - 10
XL	44 - 46	10 - 12

623* - nur / only / seulptment / S, M

ski power l/r

72.218/3

thermo control



135



010

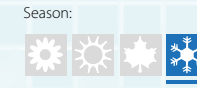

- Besonderheiten:**
- Verstärkte Hochferse
 - Luftkanäle
 - Elastzone für besseren Halt
 - Gekettelt

- Specificities:**
- Strengthened high-heel
 - Air channels
 - Elastic zone for improved support
 - Seamless

- Particularités:**
- Haut du talon renforcé
 - Canaux d'aération
 - Zone élastique pour un meilleur maintien
 - Remmaillée

- Particolarità:**
- Tallone rinforzato di altezza maggiorata
 - Canali per il passaggio dell'aria
 - Zona elastica per un supporto migliorato
 - Punta rimagliata

- Hauptvorteil:**
- Feuchtigkeitsregulierung, Wärme und Polsterung

- Main Benefit:**
- Moisture management, warmth and cushioning

- Principal avantage:**
- Régulation de l'humidité, chaleur et renfort

- Vantaggio principale:**
- Gestione dell'umidità, calore e struttura interna in spugna

- Entwickelt für:**
- Herausragender Komfort und Wärmeregulierung

- Designed For:**
- Outstanding comfort and thermoregulation

- Conçue pour:**
- Comfort exceptionnel et thermorégulation

- Progettato per:**
- Comfort eccellente e termoregolazione

- Sport / Verwendung:**
- Allmountain

- Sports / Use:**
- Allmountain

- Sports / Utilisations:**
- Tous les sports et activités de montagne

- Sport / Uso:**
- Tutti le pratiche alpinistiche

- Eigenschaften:**
- Temperaturkontrolle durch Biokeramik
 - Antibakteriell
 - Geruchshemmend
 - Vollplüschsocke
 - Anatomische Passform

- Features:**
- Temperature control through Bioceramics
 - Antibacterial
 - Anti-odor
 - Full terry construction
 - Anatomical fit

- Caractéristiques:**
- Control de la température avec Bioceramic
 - Antibactérienne
 - Anti-odeur
 - Construction pleine peluche
 - Forme anatomique

- Caratteristiche:**
- Controllo della temperatura attraverso la Bioceramica
 - Antibatterico
 - Antiodore
 - Struttura interamente in spugna
 - Calzata anatomica

37% Polyester Biokeramik / Bioceramic
 35% Polyamid
 16% Schurwolle / new wool
 10% Polyacryl
 2% Elasthan (Lycra®)



schoeller
the spinning group

Rohner	Europe	US Men's	US Women
S	36 - 38	3 - 5 1/2	4 1/2 - 6 1/2
M	39 - 41	6 - 8	7 1/2 - 9 1/2
L	42 - 44	8 1/2 - 10	10 - 11 1/2
XL	44 - 46	10 - 12	11+

r-motion

70.227/3

Cushion/Volume:



Season:



over the calf



010



Besonderheiten:

- Vollplüschsocke
- Gekettelt



Specificities:

- Full terry construction
- Seamless



Particularités:

- Construction pleine peluche
- Remmaillée



Particolarità:

- Struttura interamente in spugna
- Punta rimagliata

Hauptvorteil:

- Optimaler Komfort

Entwickelt für:

- Allround

Sport / Verwendung:

- Anfänger und Fortgeschrittene

Eigenschaften:

- Vollplüschsocke

Main Benefit:

- Optimal comfort

Designed For:

- Allround

Sports / Use:

- Beginner and advanced

Features:

- Full terry construction

Principal avantage:

- Confort optimal

Conçue pour:

- Toutes les utilisations possibles

Sports / Utilisations:

- Niveau débutant et avancé

Caractéristiques:

- Construction pleine peluche

Vantaggio principale:

- Comfort ottimale

Progettato per:

- Tutti gli impieghi

Sport / Uso:

- Sportivi principianti e di livello avanzato

Caratteristiche:

- Struttura interamente in spugna



008

009*

46% Polyacryl
37% Schurwolle / new wool
17% Polyamid



schoeller
the spinning group

Rohner	Europe	US Men's	US Women
S	36 - 38	3 - 5 1/2	4 1/2 - 6 1/2
M	39 - 41	6 - 8	7 1/2 - 9 1/2
L	42 - 44	8 1/2 - 10	10 - 11 1/2
XL	44 - 46	10 - 12	11+
XXL*	47 - 48	13 - 15	-

XXL* – nur / only / seulment / solo col.009

downhill jet

70.201/3

comfort plus

Cushion/Volume:



Season:



over the calf

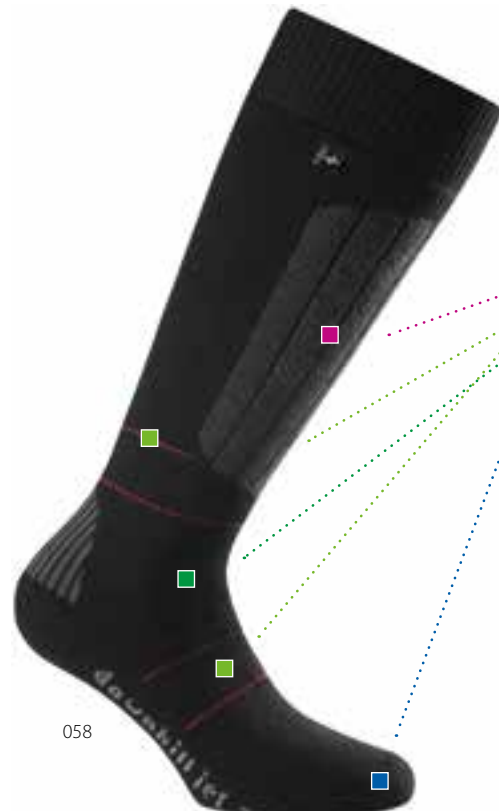

- Besonderheiten:**
- Ergonomische Polsterzone
 - Elastzone für optimalen Halt
 - Keine Falten dank «In&Out» Technologie
 - Gekettelt

- Specificities:**
- Ergonomic cushion zone
 - Elastic zone for optimal support
 - No creasing due to «In&Out» technology
 - Seamless

- Particularités:**
- Zone de rembourrage ergonomique
 - Zone élastique pour un maintien optimale
 - Absence de plis grâce à la technologie «In&Out»
 - Remmaillée

- Particolarità:**
- Zona di ammortizzamento ergonomica
 - Zona elastica per un supporto ottimale
 - Nessuna piega grazie alla tecnologia «In&Out»
 - Punta rimagliata

- Hauptvorteil:**
- Maximale Polsterung und Wärme

- Main Benefit:**
- Maximum cushioning and warmth

- Principal avantage:**
- Rembourrage et chaleur maximale

- Vantaggio principale:**
- Massimo ammortizzamento e mantenimento del calore

- Entwickelt für:**
- Höchsten Komfort

- Designed For:**
- Maximum comfort

- Conçue pour:**
- Confort maximale

- Progettato per:**
- Massimo comfort per il piede

- Sport / Verwendung:**
- Allmountain

- Sports / Use:**
- Allmountain

- Sports / Utilisations:**
- Tous les sports et activités de montagne

- Sport / Uso:**
- Tutti le pratiche alpinistiche

- Eigenschaften:**
- Schienbeinschutz
 - Vollplüschsocke
 - Weicher Abschlussrand

- Features:**
- Shinbone protection
 - Full terry construction
 - Soft border

- Caractéristiques:**
- Protection du tibia
 - Construction pleine peluche
 - Bord souple

- Caratteristiche:**
- Protezione dello stinco
 - Struttura interamente in spugna
 - Bordo morbido

058



556

114

418**

80% Schurwolle / new wool
15% Polyamid
5% Elasthan (Lycra®)



schoeller
the spinning group

Rohner	Europe	US Men's	US Women
S	36 - 38	3 - 5 1/2	4 1/2 - 6 1/2
M	39 - 41	6 - 8	7 1/2 - 9 1/2
L	42 - 44	8 1/2 - 10	10 - 11 1/2
XL	44 - 46	10 - 12	11+

** – solange Vorrat

thermal

70.036/3

natural thermo control

Cushion/Volume:



Season:



over the calf



Besonderheiten:

- Feiner Innenplüsch in der ganzen Socke
- Gekettelt



Specificities:

- Fine plush inner-layer in the whole sock
- Seamless



Particularités:

- Fine peluche intérieure dans toute la chaussette
- Remmaillée



Particolarità:

- Strato interno in raffinato peluche
- Punta rimagliata

Hauptvorteil:

- Maximale Wärme und natürliche Feuchtigkeitsregulierung

Entwickelt für:

- Herausragenden Komfort

Sport / Verwendung:

- Allmountain
- Snowsport

Eigenschaften:

- Vollplüschsocke
- Temperaturkontrolle
- Seide und Merinowolle für ein ideales Fussklima

Main Benefit:

- Maximum warmth and natural moisture management

Designed For:

- Premium comfort

Sports / Use:

- Allmountain
- Snowsport

Features:

- Full terry construction
- Thermo control
- Silk and merino wool for ideal comfort

Principal avantage:

- Chaleur maximale et gestion naturelle de l'humidité

Conçue pour:

- Confort excellent

Sports / Utilisations:

- Tous les sports et activités de montagne
- Sports d'hiver

Caractéristiques:

- Construction pleine peluche
- Régulation thermique
- Soie et laine merino pour maintenir le pied dans un climat idéal

Vantaggio principale:

- Massimo mantenimento del calore e gestione naturale dell'umidità

Progettato per:

- Comfort perfetto

Sport / Uso:

- Tutti le pratiche alpinistiche
- Sport invernali

Caratteristiche:

- Struttura interamente in spugna
- Tessuto termoregolante
- Seta e lana merino per un maggiore comfort

010

009

60% Wolle (Merino) / Wool (Merino)
20% Seide / silk
15% Polyamid
5% Elasthan (Lycra®)



Rohner	Europe	US Men's	US Women
S	36 - 38	3 - 5 1/2	4 1/2 - 6 1/2
M	39 - 41	6 - 8	7 1/2 - 9 1/2
L	42 - 44	8 1/2 - 10	10 - 11 1/2
XL	44 - 46	10 - 12	11+

thermal deluxe

70.226/3

natural thermo regulation

Cushion/Volume:



Season:



over the calf



008*

009

Besonderheiten:

- Weicher Abschlussrand
- Vollplüschsocke
- Elastzone im Ristbereich
- Gekettelt

Specificities:

- Soft border
- Full terry construction
- Elastzone in instep area
- Seamless

Particularités:

- Bords non comprimants
- Construction pleine peluche
- Zone du cou-de-pied élastique
- Remmaillée

Particolarità:

- Bordo in tessuto morbido
- Struttura interamente in spugna
- Zona elastica nell'area del collo del piede
- Punta rimagliata

Hauptvorteil:

- Temperaturregulierung
- Kaschmir und Seide

Main Benefit:

- Temperature regulating
- Cashmere and silk

Principal avantage:

- Régulation de la température
- Cachemire et soie

Vantaggio principale:

- Termoregolazione
- Filato in cashmere e seta

Entwickelt für:

- Maximale Wärme und Komfort

Designed For:

- Maximum warmth and superior comfort

Conçue pour:

- Chaleur maximale et confort supérieur

Progettato per:

- Mantenimento del calore e massimo comfort per il piede

Sport / Verwendung:

- Allmountain

Sports / Use:

- Allmountain

Sports / Utilisations:

- Tous les sports et activités de montagne

Sport / Uso:

- Tutti le pratiche alpinistiche

Eigenschaften:

- Vollplüschsocke
- Elastzone im Ristbereich

Features:

- Full terry construction
- Elastic zone in instep area

Caractéristiques:

- Construction pleine peluche
- Zone du cou-de-pied élastique

Caratteristiche:

- Struttura interamente in spugna
- Zona elastica nell'area del collo del piede

38% Wolle (Merino) / Wool (Merino)
29% Polyamid
16% Seide / silk
16% Kaschmir
1% Elasthan (Lycra®)



Rohner	Europe	US Men's	US Women
S*	36 - 38	3 - 5 1/2	4 1/2 - 6 1/2
M*	39 - 41	6 - 8	7 1/2 - 9 1/2
L*	42 - 44	8 1/2 - 10	10 - 11 1/2
XL	44 - 46	10 - 12	11+

008* – nur / only / seulment / solo S, M, L

native

70.253/3



009



010

Besonderheiten:
■ Vollplüschsocke

Specificities:
■ Full terry construction

Particularités:
■ Construction pleine peluche

Particolarità:
■ Struttura interamente in spugna

Hauptvorteil:
■ Optimaler Komfort

Main Benefit:
■ Optimal comfort

Principal avantage:
■ Confort optimal

Vantaggio principale:
■ Comfort ottimale

Entwickelt für:
■ Allround

Designed For:
■ Allround

Conçue pour:
■ Toutes les utilisations possibles

Progettato per:
■ Tutti gli impieghi

Sport / Verwendung:
■ Ski / Snowboard

Sports / Use:
■ Ski / Snowboard

Sports / Utilisations:
■ Ski / Snowboard

Sport / Uso:
■ Sci / Snowboard

Eigenschaften:
■ Vollplüschsocke
■ Flachnaht

Features:
■ Full terry construction
■ Flat seam

Caractéristiques:
■ Construction pleine peluche
■ Couture plate

Caratteristiche:
■ Struttura interamente in spugna
■ Cucitura piatta



46% Polyacryl
37% Schurwolle / new wool
17% Polyamid



schoeller
the spinning group

Rohner	Europe	US Men's	US Women
S	36 - 38	3 - 5 1/2	4 1/2 - 6 1/2
M	39 - 41	6 - 8	7 1/2 - 9 1/2
L	42 - 44	8 1/2 - 10	10 - 11 1/2
XL	44 - 46	10 - 12	11+

carola

70.228/3



661



157***

304

Besonderheiten:
■ Vollplüschsocke

Specificities:
■ Full terry construction

Particularités:
■ Construction pleine peluche

Particolarità:
■ Struttura interamente in spugna

Hauptvorteil:
■ Optimaler Komfort

Main Benefit:
■ Optimal comfort

Principal avantage:
■ Confort optimal

Vantaggio principale:
■ Comfort ottimale

Entwickelt für:
■ Allround

Designed For:
■ Allround

Conçue pour:
■ Toutes les utilisations possibles

Progettato per:
■ Tutti gli impieghi

Sport / Verwendung:
■ Ski / Snowboard

Sports / Use:
■ Ski / Snowboard

Sports / Utilisations:
■ Ski / Snowboard

Sport / Uso:
■ Sci / Snowboard

Eigenschaften:
■ Vollplüschsocke
■ Flachnaht

Features:
■ Full terry construction
■ Flat seam

Caractéristiques:
■ Construction pleine peluche
■ Couture plate

Caratteristiche:
■ Struttura interamente in spugna
■ Cucitura piatta

Cushion/Volume:



Season:



over the calf



46% Polyacryl
37% Schurwolle / new wool
17% Polyamid



schoeller
the spinning group

Rohner	Europe	US Men's	US Women
S	36 - 38	3 - 5 1/2	4 1/2 - 6 1/2
M	39 - 41	6 - 8	7 1/2 - 9 1/2
L	42 - 44	8 1/2 - 10	10 - 11 1/2
XL	44 - 46	10 - 12	11+

*** - Limited Edition

compression ski light l/r

62.249/3

energy socks



Cushion/Volume:



Season:



over the calf

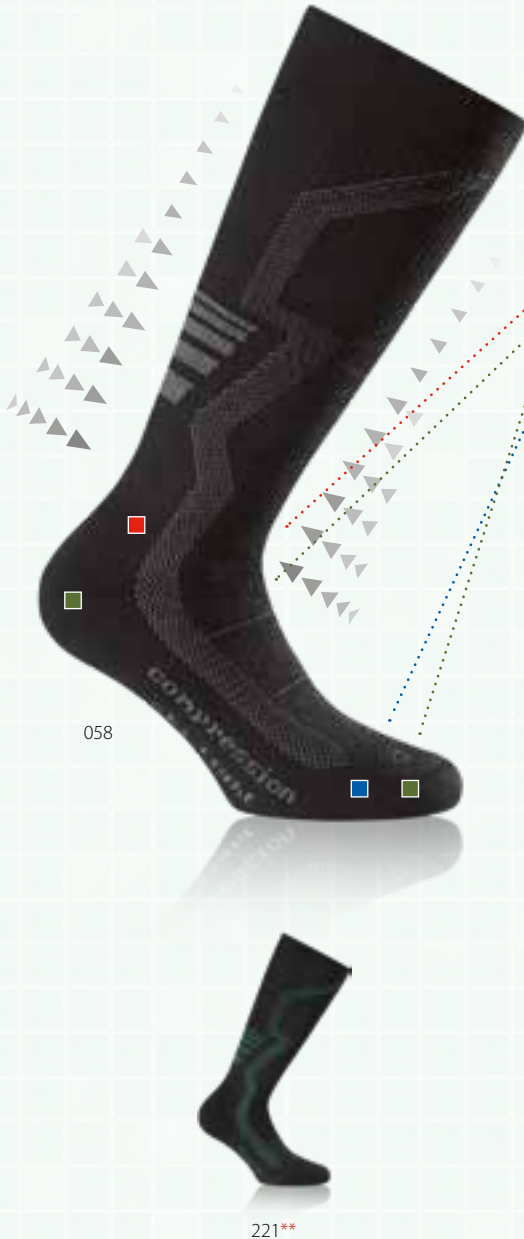

Besonderheiten:

- Verstärkte Hochferse
- Spitze und Ferse mit Profilen® (Blister Free)
- Gekettelt

Specificities:

- Strengthened high-heel
- Toe and heel area with Profilen® (Blister Free)
- Seamless

Particularités:

- Haut du talon renforcé
- Pointes et talons hauts Profilen® (Blister Free)
- Remmaillée

Particolarità:

- Tallone rinforzato di altezza maggiorata
- Punta e parte alta del tallone con Profilen® (Blister Free)
- Punta rimagliata

Hauptvorteil:

- Verbesserte Durchblutung
- Entspannung der Muskulatur
- Verbesserte Regenerationsfähigkeit
- Entsäuerung der Muskulatur

Main Benefit:

- Improved circulation
- Relaxing muscles
- Improved ability to regenerate
- Acidification of the muscles

Principal avantage:

- Amélioration de la circulation du sang
- Relaxation de la musculature
- Amélioration de la capacité de régénération
- Désacidification de la musculature

Vantaggio principale:

- Miglioramento della circolazione del sangue
- Rilassamento della muscolatura
- Maggiore capacità di rigenerazione muscolare
- Disacidificazione dei muscoli

Entwickelt für:

- Optimale Kraftübertragung
- Direkten Schuhkontakt

Designed For:

- Optimal power transmission
- Close shoe contact

Conçue pour:

- Transfert d'énergie optimal
- Contact étroit avec la chaussure

Progettato per:

- Trasmissione ottimale della potenza
- Massima aderenza alla calzatura

Sport / Verwendung:

- Skifahren
- Tourenskifahren
- Langlauf
- Schneelaufen

Sports / Use:

- Skiing
- Skiing Tour
- Cross-country skiing
- Snow walking

Sports / Utilisations:

- Ski
- Tour de Ski
- Ski nordic
- Raquette

Sport / Uso:

- Sci
- Sci Tour
- Sci nordico
- Racchette

Eigenschaften:

- Temperaturkontrolle
- Plüsch im Fussbereich und Schienbein

Features:

- Thermo control
- Terry construction in foot area and shinbone

Caractéristiques:

- Régulation thermique
- Peluche dans la zone du pied et tibia

Caratteristiche:

- Termoregolante
- Spugna nel piede e sullo stinco

32% Polyester Biokeramik / Bioceramic
28% Polyamid
16% Wolle / Wool
17% Polyacryl
4% Profilen
3% Elasthan



Rohner	Europe	US Men's	US Women
S	36 - 38	3 - 5 1/2	4 1/2 - 6 1/2
M	39 - 41	6 - 8	7 1/2 - 9 1/2
L	42 - 44	8 1/2 - 10	10 - 11 1/2
XL	44 - 46	10 - 12	11+

** - solange Vorrat

Trekking

über Stock und Stein



trek'n travel l/r

62.011/2

wellness



Cushion/Volume:



Season:



1/4 crew

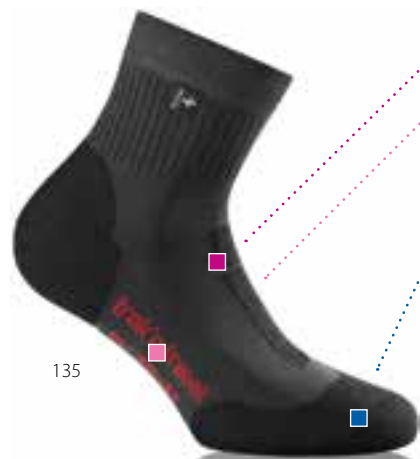

135



304***

031***

003***

047***

Besonderheiten:

- Die spezielle Polsterung schützt vor Druckstellen am Rist
- Plüsch im Fussbereich
- Gekettelt

Specificities:

- The special chushion prevents pressure spots on the instep
- Terry construction in foot area
- Seamless

Particularités:

- Le renforcement spécial protège le cou-de-pied des zones de pression
- Peluche dans la zone du pied
- Remmaillée

Particolarità:

- La speciale imbottitura evita punti di pressione nel collo del piede
- Interno in tessuto felpato nella zona del piede
- Punta rimagliata

Hauptvorteil:

- Geringes Gewicht und Fusskomfort

Main Benefit:

- Lightweight and Foot Wellness

Principal avantage:

- Poids léger et bien-être du pied

Vantaggio principale:

- Leggerezza e benessere del piede

Entwickelt für:

- Wandern
- Freizeit

Designed For:

- Hiking
- Leisure

Conçue pour:

- Randonnées
- Loisirs

Progettato per:

- Marcia
- Tempo libero

Sport / Verwendung:

- Wandern
- Geländelauf
- Laufen

Sports / Use:

- Hiking
- Trail Running
- Walking

Sports / Utilisations:

- Randonnée pédestre
- Course sur sentier
- Marche

Sport / Uso:

- Escursionismo
- Corsa in natura
- Marcia

Eigenschaften:

- Antibakteriell
- Geruchshemmend
- Antistatisch
- Ristpolsterung
- Plüsch im Fussbereich
- Natürliche Feuchtigkeitsregulierung
- Für Schuhe mit Membranfutter
- Fuss-Wellness
- Anatomische Passform

Features:

- Antibacterial
- Anti-odor
- Antistatic
- Instep cushioning
- Terry construction in foot area
- Natural moisture management
- For membran liner footwear
- Foot wellness
- Anatomical fit

Caractéristiques:

- Antibactérienne
- Anti-odeur
- Antistatique
- Protection du cou-de-pied
- Peluche dans la zone du pied
- Gestion naturelle de l'humidité
- Pour chaussures doublées en membrane
- Bien-être du pied
- Forme anatomique

Caratteristiche:

- Antibatterico
- Antiodore
- Antistatico
- Protezione del collo del piede
- Interno in tessuto felpato nella zona del piede
- Gestione naturale dell'umidità
- Per calzature con fodera interna
- Benessere del piede
- Calzata anatomica

34% Polyamid
28% Baumwolle / cotton
25% Polypropylen
12% Smartcel® Sensitive
1% Elasthan (Lycra®)

smartcel™
sensitive

LYCRA
ultrafine

Rohner	Europe	US Men's	US Women
S	36 - 38	3 - 5 1/2	4 1/2 - 6 1/2
M	39 - 41	6 - 8	7 1/2 - 9 1/2
L	42 - 44	8 1/2 - 10	10 - 11 1/2
XL	44 - 46	10 - 12	11+

*** - Limited Edition

mountain trekking l/r

62.012/1

wellness



Cushion/Volume:



Season:



crew cut



135



Besonderheiten:

- Die spezielle Polsterung schützt vor Druckstellen am Rist
- Plüsch im Fussbereich
- Gekettelt



Specificities:

- The special chushion on the instep
- Terry construction in foot area
- Seamless



Particularités:

- Le renforcement spécial protège le cou-de-pied des zones de pression
- Peluche dans la zone du pied
- Remmaillée



Particolarità:

- La speciale imbottitura evita punti di pressione nel collo del piede
- Interno in tessuto felpato nella zona del piede
- Punta rimagliata

Hauptvorteil:

- Maximaler Fusskomfort

Main Benefit:

- Maximum foot comfort

Principal avantage:

- Confort du pied maximale

Vantaggio principale:

- Calzata perfetta e prestazioni ottimali

Entwickelt für:

- Wärmere Klimazonen

Designed For:

- Warmer Climate

Conçue pour:

- Climat plus chaud

Progettato per:

- Clima più caldo

Sport / Verwendung:

- Wandern
- Bergtouren

Sports / Use:

- Trekking
- Hiking

Sports / Utilisations:

- Trekking
- Randonnée pédestre

Sport / Uso:

- Trekking
- Escursionismo

Eigenschaften:

- Antibakteriell
- Geruchshemmend
- Antistatisch
- Ristpolsterung
- Schienbeinpolsterung
- Plüsch im Fussbereich
- Fuss-Wellness
- Anatomische Passform

Features:

- Antibacterial
- Anti-odor
- Antistatic
- Instep cushioning
- Shinbone protection
- Terry construction in foot area
- Foot wellness
- Anatomical fit

Caractéristiques:

- Antibactérienne
- Anti-odeur
- Antistatique
- Protection du cou-de-pied
- Protection du tibia
- Peluche dans la zone du pied
- Bien-être du pied
- Forme anatomique

Caratteristiche:

- Antibatterico
- Antiodore
- Antistatico
- Protezione del collo del piede
- Protezione dello stinco
- Interno in tessuto felpato nella zona del piede
- Benessere del piede
- Calzata anatomica



304***

031***

003***

047***

27% Polyamid
25% Baumwolle / cotton
20% Polyacryl
16% Schurwolle / new wool
11% Smartcel®Sensitive
1% Elasthan (Lycra®)



fresh



schoeller
the spinning group



Rohner	Europe	US Men's	US Women
S	36 - 38	3 - 5 1/2	4 1/2 - 6 1/2
M	39 - 41	6 - 8	7 1/2 - 9 1/2
L	42 - 44	8 1/2 - 10	10 - 11 1/2
XL	44 - 46	10 - 12	11+

*** - Limited Edition

SAC trek-light l/r

62.019/6 *Limited Edition*

wellness



561 **/**

trek-light l/r

62.019/1



186



Cushion/Volume:



Season:



crew cut

**Besonderheiten:**

- Rohner Air Channel-System im Fussbereich
- Die spezielle Polsterung schützt vor Druckstellen am Rist
- Plüsch im Fussbereich
- Gekettelt

**Specificities:**

- Rohner Air Channel System in foot area
- The special chushion prevents pressure on the instep
- Terry construction in foot area
- Seamless

**Particularités:**

- Circulation de l'air optimisée par le Rohner Air Channel System
- Le renforcement spécial protège le cou-de-pied des zones de pression
- Peluche dans la zone du pied
- Remmailée

**Particolarità:**

- Sistema Rohner Air Channel System nell'area del piede
- La speciale imbottitura evita punti di pressione nel collo del piede
- Interno in tessuto felpato nella zona del piede
- Punta rimagliata

Hauptvorteil:

- Maximaler Fusskomfort

Main Benefit:

- Maximum foot comfort

Principal avantage:

- Confort du pied maximale

Vantaggio principale:

- Calzata perfetta e prestazioni ottimali

Entwickelt für:

- Wärmere Klimazonen

Designed For:

- Warmer Climate

Conçue pour:

- Climat plus chaud

Progettato per:

- Clima più caldo

Sport / Verwendung:

- Wandern
- Bergtouren

Sports / Use:

- Trekking
- Hiking

Sports / Utilisations:

- Trekking
- Randonnée pédestre

Sport / Uso:

- Trekking
- Escursionismo

Eigenschaften:

- Antibakteriell
- Geruchshemmend
- Ristpolsterung
- Plüsch im Fussbereich
- Fuss-Wellness
- Anatomische Passform
- R.A.C.S.

Features:

- Antibacterial
- Anti-odor
- Instep cushioning
- Terry construction in foot area
- Foot wellness
- Anatomical fit
- R.A.C.S.

Caractéristiques:

- Antibactérienne
- Anti-odeur
- Protection du cou-de-pied
- Peluche dans la zone du pied
- Bien-être du pied
- Forme anatomique
- R.A.C.S.

Caratteristiche:

- Antibatterico
- Antiodore
- Protezione del collo del piede
- Interno in tessuto felpato nella zona del piede
- Benessere del piede
- Calzata anatomica
- Sistema R.A.C.S.

27% Polyamid
25% Baumwolle / cotton
20% Polyacryl
16% Schurwolle / new wool
11% Smartcel® Sensitive
1% Elasthan (Lycra®)



Rohner	Europe	US Men's	US Women
S	36 - 38	3 - 5 1/2	4 1/2 - 6 1/2
M	39 - 41	6 - 8	7 1/2 - 9 1/2
L	42 - 44	8 1/2 - 10	10 - 11 1/2
XL	44 - 46	10 - 12	11+
XXL*	47 - 48	12 1/2 - 13	-

* - nur / only / seulement / solo col. 561

*** - Limited Edition

SAC copper trek I/r

62.213/6 *Limited Edition*



135

copper trek I/r

62.213/1



181



Cushion/Volume:



Season:



crew cut



- Besonderheiten:**
- Verstärkte Hochferse
 - Plüsch im Fussbereich
 - Ristpolsterung



- Specificities:**
- Reinforced high-heel
 - Terry construction in foot area
 - Instep cushioning



- Particularités:**
- Haut du talon renforcé
 - Peluche dans la zone du pied
 - Rembourrage du cou-de-pied



- Particolarità:**
- Tallone rinforzato
 - Interno in tessuto felpato nella zona del piede
 - Imbottitura del collo del piede

Hauptvorteil:

- Mildert Hauptprobleme an Füßen (Anti-Fusspilz)
- Maximaler Fusskomfort

Main Benefit:

- Attenuates the skin problems of the feet (antifungal)
- Maximum comfort for the feet

Principal avantage:

- Atténue les problèmes de peau des pieds (antifongique)
- Comfort maximum des pieds

Vantaggio principale:

- Attenua i problemi per pelli delicate (anti-fungine)
- Massimo conforto del piede

Entwickelt für:

- Hautprobleme an Füßen
- Trockene Füße

Designed For:

- Skin problems on the feet
- Dry feet

Conçue pour:

- Problèmes de peau aux pieds
- Pieds secs

Progettato per:

- Problemi di pelle ai piedi
- Piedi con pelle disidratata

Sport / Verwendung:

- Rucksacktouren
- Wandern
- Bergtouren

Sports / Use:

- Backpacking trips
- Hiking
- Mountain tours

Sports / Utilisations:

- Voyages en sac à dos
- Randonnée
- Randonnées en montagne

Sport / Uso:

- Viaggi con lo zaino in spalla
- Escursionismo
- Escursioni in montagna

Eigenschaften:

- Antibakteriell
- Antimykotisch
- Geruchshemmend
- Hautfreundlich
- Mildert Hautrötungen, Fissuren, Bläschenbildung, Schuppen, Juckreiz
- Flachnaht

Features:

- Antibacterial
- Antifungal
- Anti-odor
- Gentle for the skin
- Reduces redness, cracks, blisters, dandruff, burns and itching of the skin
- Flat seam

Caractéristiques:

- Antibactérienne
- Antifongique
- Anti-odeur
- Doux pour la peau
- Atténue les rougeurs, les crevasses, les cloques, les pellicules et les démangeaisons de la peau
- Couture plate

Caratteristiche:

- Antibatterico
- Antimicotico
- Antiodore
- Delicato sulla pelle
- Attenua gli arrossamenti, le screpolature, la formazione di vesciche, la desquamazione e il prurito
- Cucitura piatta

58% Baumwolle
30% Cupron (18% Kupfer-Polyester / Copper -Polyester, 12% Baumwolle / Cotton)
9% Elasthan
3% Polyamid



Rohner	Europe	US Men's	US Women
S	36 - 38	3 - 5 1/2	4 1/2 - 6 1/2
M	39 - 41	6 - 8	7 1/2 - 9 1/2
L	42 - 44	8 1/2 - 10	10 - 11 1/2
XL	44 - 46	10 - 12	11+
XXL	47 - 48	12 1/2 - 13	

trek-power l/r

62.212/1

Cushion/Volume:



Season:



crew cut



009*

Besonderheiten:

- Verstärkte Hochferse
- Knöchelschutz
- Plüsch im Fussbereich
- Gekettelt

Specificities:

- Reinforced high-heel
- Ankle protection
- Terry construction in foot area
- Seamless

Particularités:

- Haut du talon renforcé
- Protection de la cheville
- Peluche dans la zone du pied
- Remmaillée

Particolarità:

- Tallone rinforzato di altezza maggiorata
- Protezione per la caviglia
- Interno in tessuto felpato nella zona del piede
- Punta rimagliata

Hauptvorteil:

- Temperaturregulierung

Main Benefit:

- Temperature regulating

Principal avantage:

- Régulation de la température

Vantaggio principale:

- Termoregolazione

Entwickelt für:

- Outdoor

Designed For:

- All Outdoor

Conçue pour:

- Tous les sports et activités de plein air

Progettato per:

- Tutti gli ambienti esterni

Sport / Verwendung:

- Wandern
- Freizeit

Sports / Use:

- Trekking
- Leisure

Sports / Utilisations:

- Trekking
- Loisirs

Sport / Uso:

- Trekking
- Tempo libero

Eigenschaften:

- Temperaturkontrolle durch Biokeramik und Carbon
- Antistatisch
- Plüsch im Fussbereich
- Weicher Abschlussrand
- Knöchelschutz
- Anatomische Passform
- Antibakteriell

Features:

- Temperature control through Bioceramic and Carbon
- Antistatic
- Terry construction in foot area
- Soft border
- Ankle protection
- Anatomical fit
- Antibacterial

Caractéristiques:

- Contrôle de la température à travers la bioceramique et le carbone
- Antistatique
- Peluche dans la zone du pied
- Bord souple
- Protection de la cheville
- Forme anatomique
- Antibactérienne

Caratteristiche:

- Termoregolazione grazie alla Bioceramica e al Carbon
- Antistatico
- Interno in tessuto felpato nella zona del piede
- Bordo morbido
- Protezione della stinco
- Calzata anatomica
- Antibatterico



003**

010

401

41% Polyester Biokeramik / Bioceramic
35% Carcot (31% Baumwolle / Cotton, 4% Carbon)
21% Polyamid
3% Elasthan (Lycra®)



XXL* – nur / only / seulement / solo col. 009

** – solange Vorrat

Rohner	Europe	US Men's	US Women
S	36 - 38	3 - 5 1/2	4 1/2 - 6 1/2
M	39 - 41	6 - 8	7 1/2 - 9 1/2
L	42 - 44	8 1/2 - 10	10 - 11 1/2
XL	44 - 46	10 - 12	11+
XXL*	47 - 49	13 - 15	-

fibre light quarter

60.039/2

trek'n work



Cushion/Volume:



Season:



1/4 crew



009



115



123*



Besonderheiten:

- Plüsch im Fussbereich
- Elastzone für besseren Halt
- Gekettelt



Specificities:

- Terry construction in foot area
- Elastic zone for improved support
- Seamless



Particularités:

- Peluche dans la zone du pied
- Zone élastique pour un meilleur maintien
- Remmaillée



Particolarità:

- Interno in tessuto felpato nella zona del piede
- Zona elastica per un supporto migliorato
- Punta rimagliata

Hauptvorteil:

- Fusskomfort

Entwickelt für:

- Komfort bei geringem Gewicht
- Schuhe mit Membranfutter

Sport / Verwendung:

- Wandern
- Laufen
- Arbeiten

Eigenschaften:

- Fusskomfort
- Natürliche Feuchtigkeitsregulierung
- Für Schuhe mit Membranfutter

Main Benefit:

- Foot wellness

Designed For:

- Lightweight Comfort
- Membran lined boots

Sports / Use:

- Hiking
- Walking
- Working

Features:

- Foot wellness
- Natural moisture management
- For membran liner footwear

Principal avantage:

- Bien-être du pied

Conçue pour:

- Confort léger
- Chaussures doublées en membrane

Sports / Utilisations:

- Randonnée pédestre
- Marche
- Travail

Caractéristiques:

- Bien-être du pied
- Peluche dans la zone du pied
- Pour chaussures doublées de membrane

Vantaggio principale:

- Benessere del piede

Progettato per:

- Leggerezza e comfort
- Scarponi con fodera interna

Sport / Uso:

- Escursionismo
- Marcia
- Lavoro

Caratteristiche:

- Benessere del piede
- Gestione naturale dell'umidità
- Per calzature con fodera interna

42% Wolle (Merino) / Wool (Merino)
41% Polyamid
15% Polypropylen
2% Elasthan (Lycra®)



Rohrer	Europe	US Men's	US Women
S	36 - 38	3 - 5 1/2	4 1/2 - 6 1/2
M	39 - 41	6 - 8	7 1/2 - 9 1/2
L	42 - 44	8 1/2 - 10	10 - 11 1/2
XL	44 - 46	11 - 12	11+
XXL*	47 - 49	13 - 15	-

* - nur / only / seulment / solo col. 123

fibre light superR

60.039/1

trek'n work



Cushion/Volume:



Season:



crew cut



123*

- Besonderheiten:**
- Rutschfestes Rohr
 - Plüsch im Fussbereich
 - Gekettelt

- Hauptvorteil:**
- Rutschfestes Rohr

- Entwickelt für:**
- Komfort bei geringem Gewicht
 - Schuhe mit Membranfutter

- Sport / Verwendung:**
- Wandern
 - Laufen
 - Arbeiten

- Eigenschaften:**
- Rutschfestes Rohr
 - Natürliche Feuchtigkeitsregulierung
 - Plüsch im Fussbereich
 - Für Schuhe mit Membranfutter

- Specificities:**
- Anti-slip tube
 - Terry construction in foot area
 - Seamless

- Main Benefit:**
- Anti-slip Tube

- Designed For:**
- Lightweight Comfort
 - Membran lined boots

- Sports / Use:**
- Hiking
 - Walking
 - Working

- Features:**
- Antislip tube
 - Natural moisture management
 - Terry construction in foot area
 - For membran liner footwear

- Particularités:**
- Tricot jambe anti-glissement
 - Peluche dans la zone du pied
 - Remmaillée

- Principal avantage:**
- Tricot jambe antiglisse

- Conçue pour:**
- Confort léger
 - Chaussures doublées en membrane

- Sports / Utilisations:**
- Randonnée pédestre
 - Marche
 - Travail

- Caractéristiques:**
- Tricot jambe antiglisse
 - Peluche dans la zone du pied
 - Gestion naturelle de l'humidité
 - Pour chaussures doublées de membrane

- Particolarità:**
- Tubo antiscivolo
 - Interno in tessuto felpato nella zona del piede
 - Punta rimagliata

- Vantaggio principale:**
- Tubo antiscivolo

- Progettato per:**
- Leggerezza e comfort
 - Scarponi con fodera interna

- Sport / Uso:**
- Escursionismo
 - Marcia
 - Lavoro

- Caratteristiche:**
- Tubo antiscivolo
 - Gestione naturale dell'umidità
 - Interno in tessuto felpato nella zona del piede
 - Per calzature con fodera interna



009 070 115 047 276 145 181 425*** 466***

42% Wolle (Merino) / Wool (Merino)
41% Polyamid
15% Polypropylen
2% Elasthan (Lykra®)



Rohrer	Europe	US Men's	US Women
S	36 - 38	3 - 5 1/2	4 1/2 - 6 1/2
M	39 - 41	6 - 8	7 1/2 - 9 1/2
L	42 - 44	8 1/2 - 10	10 - 11 1/2
XL	44 - 46	11 - 12	11+
XXL*	47 - 49	13 - 15	-

XXL* - nur / only / seulement / solo col. 123
*** - Limited Edition

hiking

60.246/1



141*



135

009*

329

Besonderheiten:

- Spezielle Polsterzonen im Rist- und Schienbeinbereich
- Gepolsterte Hochferse
- Elastzone im Fussbereich
- Gekettelt

Hauptvorteil:

- Thermoregulierung

Entwickelt für:

- Trekking

Sport / Verwendung:

- Rucksacktouren
- Wandern
- Bergtouren

Eigenschaften:

- Ristpolsterung
- Schienbeinschutz
- Plüsch im Fussbereich
- Thermoregulierung

52% Polyester (Thermocool)
25% Polyamid
22% Wolle (Merino) / Wool (Merino)
1% Elasthan (Lycra®)

Specificities:

- Special padding zones in the instep and shinbone
- Padded high heel
- Elastic zone in foot area
- Seamless

Main Benefit:

- Thermoregulation

Designed For:

- Trekking

Sports / Use:

- Backpacking
- Trekking
- Hiking

Features:

- Instep cushioning
- Shinbone protection
- Terry construction in foot area
- Thermoregulation



Cushion/Volume:



Season:



crew cut



Particularités:

- Rembourrage cou de pied et tibia
- Haut du talon rembourré
- Renforcement élastique dans la zone du pied
- Remmaillée

Principal avantage:

- Régulation thermique

Conçue pour:

- Trekking

Sports / Utilisations:

- Grande randonnée
- Trekking
- Randonnée pédestre

Caractéristiques:

- Protection du cou-de-pied
- Protection du tibia
- Peluche dans la zone du pied
- Régulation thermique

Particolarità:

- Speciali imbottiture nella zona del collo del piede e dello stinco
- Parte alta del tallone imbottita
- Zona elastica nell'area del piede
- Punta rimagliata

Vantaggio principale:

- Termoregolante

Progettato per:

- Trekking

Sport / Uso:

- Turismo con zaino
- Trekking
- Escursionismo

Caratteristiche:

- Protezione del collo del piede
- Protezione dello stinco
- Interno in tessuto felpato nella zona del piede
- Termoregolante

Rohrer	Europe	US Men's
S*	36 - 38	3 - 5 1/2
M*	39 - 41	6 - 8
L	42 - 44	8 1/2 - 10
XL	44 - 46	10 - 12
XXL*	47 - 49	12 - 14

XXL* – nur / only / seulment / solo col. 009
col. 141* – nur / only / seulement / solo in S/M

back-country l/r

62.210/1

moisture management

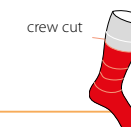

181



135

304***

008*

Besonderheiten:

- Weicher Abschlussrand
- Rist- und Schienbeinpolsterung
- Knöchelschutz
- Plüsch im Fussbereich
- Elastzone im Ristbereich
- Gekettelt

Hauptvorteil:

- Feuchtigkeitsregulierung

Entwickelt für:

- Optimales Fussklima

Sport / Verwendung:

- Rucksacktouren
- Wandern
- Bergtouren

Eigenschaften:

- Antibakteriell
- Geruchshemmend
- Antistatisch
- Schienbein- und Ristpolsterung
- Feuchtigkeitsregulierung
- Knöchelschutz
- Plüsch im Fussbereich
- Für Schuhe mit Membranfutter geeignet
- Weicher Abschlussrand
- Anatomische Passform

40% Wolle (Merino) / Wool (Merino)
 33% Polyacryl
 9% Polypropylen
 9% Polyamid
 8% Polyamid (MerylSkinlife®)
 1% Elasthan (Lycra®)

Specificities:

- Soft border
- Instep and shinbone cushioning
- Ankle protection
- Terry construction in foot area
- Elastic zone in instep area
- Seamless

Main Benefit:

- Moisture management

Designed For:

- Optimal foot climate

Sports / Use:

- Backpacking
- Trekking
- Hiking

Features:

- Antibacterial
- Anti-odor
- Antistatic
- Instep protection
- Shinbone protection
- Ankle protection
- Terry construction in foot area
- For membran liner footwear
- Soft border
- Anatomical fit



fresh CLIMAYARN®
 Combines nature and high-performance

schoeller
 the spinning group

Particularités:

- Bords non comprimants
- Rembourrage cou-de-pied et tibia
- Protection de la cheville
- Peluche dans la zone du pied
- Zone du cou-de-pied élastique
- Remmaillée

Principal avantage:

- Gestion de l'humidité

Conçue pour:

- Climatisation optimale du pied

Sports / Utilisations:

- Grande randonnée
- Trekking
- L'alpinisme

Caractéristiques:

- Antibactérienne
- Anti-odeur
- Antistatique
- Protection du cou-de-pied
- Protection du tibia
- Protection de la cheville
- Peluche dans la zone du pied
- Pour chaussures doublées en membrane
- Bords non comprimants
- Forme anatomique

Particolarità:

- Bordo in tessuto morbido
- Imbottitura nella zone del collo del piede e dello stinco
- Protezione per la cavaglia
- Interno in tessuto felpato nella zona del piede
- Zona elastica nell'area del collo del piede
- Punta rimagliata

Vantaggio principale:

- Gestione dell'umidità

Progettato per:

- Clima ottimale per il piede

Sport / Uso:

- Turismo con zaino
- Trekking
- Escursionismo

Caratteristiche:

- Antibatterico
- Antiodore
- Antistatico
- Protezione del collo del piede
- Protezione dello stinco
- Protezione per la cavaglia
- Interno in tessuto felpato nella zona del piede
- Per calzature con fodera interna
- Bordo in tessuto morbido
- Calzata anatomica

Rohrer	Europe	US Men's
S*	36 - 38	3 - 5 1/2
M*	39 - 41	6 - 8
L	42 - 44	8 1/2 - 10
XL	44 - 46	10 - 12

*** - Limited Edition
 col. 008* - nur / only / seulement / solo in S/M

SAC fibre high tech

60.200/6 *Limited Edition*



Cushion/Volume:



Season:



crew cut

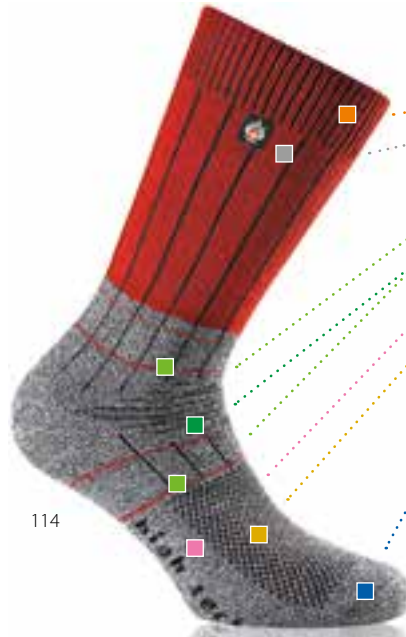

Besonderheiten:

- Weicher Abschlussrand
- SAC-Emblem
- Elastzone für besseren Halt
- «IN&OUT» Technologie
- Plüsch im Fussbereich
- Pique-Technik für bessere Passform im Fussrückbereich
- Gekettelt

Specificities:

- Soft border
- SAC-Emblem
- Elastic zone for improved support
- «IN&OUT» Technology
- Terry construction in foot area
- Pique knit for improved fit around the back of the foot
- Seamless

Particularités:

- Bords non comprimants
- SAC-Emblem
- Zone élastique pour un meilleur maintien
- Technologie de «IN&OUT»
- Peluche dans la zone du pied
- Technique piqué pour un meilleur ajustement au niveau du dos du pied
- Remmaillée

Particolarità:

- Bordo in tessuto morbido
- SAC-Emblem
- Zona elastica per un supporto migliorato
- Tecnologia «IN&OUT»
- Interno in tessuto felpato nella zona del piede
- Piqué per una calzata migliorata attorno al collo del piede
- Punta rimagliata

Hauptvorteil:

- Feuchtigkeitsregulierung

Main Benefit:

- Moisture management

Principal avantage:

- Gestion de l'humidité

Vantaggio principale:

- Gestione dell'umidità

Entwickelt für:

- Schuhe mit Membranfutter

Designed For:

- Membrane lined boots

Conçue pour:

- Chaussures doublées en membrane

Progettato per:

- Scarponi con fodera interna

Sport / Verwendung:

- Wandern
- Bergtouren

Sports / Use:

- Trekking
- Hiking

Sports / Utilisations:

- Trekking
- L'alpinisme

Sport / Uso:

- Trekking
- Escursionismo

Eigenschaften:

- Plüsch im Fussbereich
- Natürliche Feuchtigkeitsregulierung
- Für Schuhe mit Membranfutter
- Weicher Abschlussrand
- Pique-Struktur

Features:

- Terry construction in foot area
- Natural moisture management
- For membran liner footwear
- Soft border
- Pique structure

Caractéristiques:

- Peluche dans la zone du pied
- Gestion naturelle de l'humidité
- Pour chaussures doublées en membrane
- Bords non comprimants
- Structure de piqué

Caratteristiche:

- Interno in tessuto felpato nella zona del piede
- Gestione naturale dell'umidità
- Per calzature con fodera interna
- Bordo in tessuto morbido
- Struttura piqué

114

49% Polyester (Coolmax®)
 30% Wolle (Merino) / Wool (Merino)
 12% Polyacryl
 7% Polypropylen
 1% Polyamid
 1% Elasthan (Lycra®)



Rohner	Europe	US Men's	US Women
S	36 - 38	3 - 5 1/2	4 1/2 - 6 1/2
M	39 - 41	6 - 8	7 1/2 - 9 1/2
L	42 - 44	8 1/2 - 10	10 - 11 1/2
XL	44 - 46	10 - 12	11+
XXL	47 - 49	13 - 15	-

fibre high tech

60.200/1



Cushion/Volume:



Season:



crew cut



135*

Besonderheiten:

- Weicher Abschlussrand
- Elastzone für besseren Halt
- »IN&OUT« Technologie
- Plüsch im Fussbereich
- Pique-Technik für bessere Passform im Fussrückenbereich
- Gekettelt

Specificities:

- Soft border
- Elastic zone for improved support
- «IN&OUT» Technology
- Terry construction in foot area
- Pique knit for improved fit around the back of the foot
- Seamless

Particularités:

- Bords non comprimants
- Zone élastique pour un meilleur maintien
- Technologie de «IN&OUT»
- Peluche dans la zone du pied
- Technique piqué pour un meilleur ajustement au niveau du dos du pied
- Remmaillée

Particolarità:

- Bordo in tessuto morbido
- Zona elastica per un supporto migliorato
- Tecnologia «IN&OUT»
- Interno in tessuto felpato nella zona del piede
- Piqué per una calzata migliorata attorno al collo del piede
- Punta rimagliata

Hauptvorteil:

- Feuchtigkeitsregulierung

Main Benefit:

- Moisture management

Principal avantage:

- Gestion de l'humidité

Vantaggio principale:

- Gestione dell'umidità

Entwickelt für:

- Schuhe mit Membranfutter

Designed For:

- Membrane lined boots

Conçue pour:

- Chaussures doublées en membrane

Progettato per:

- Scarponi con fodera interna

Sport / Verwendung:

- Wandern
- Bergtouren

Sports / Use:

- Trekking
- Hiking

Sports / Utilisations:

- Trekking
- L'alpinisme

Sport / Uso:

- Trekking
- Escursionismo

Eigenschaften:

- Plüsch im Fussbereich
- Natürliche Feuchtigkeitsregulierung
- Für Schuhe mit Membranfutter
- Weicher Abschlussrand
- Pique-Struktur

Features:

- Terry construction in foot area
- Natural moisture management
- For membran liner footwear
- Soft border
- Pique structure

Caractéristiques:

- Peluche dans la zone du pied
- Gestion naturelle de l'humidité
- Pour chaussures doublées en membrane
- Bords non comprimants
- Structure de piqué

Caratteristiche:

- Interno in tessuto felpato nella zona del piede
- Gestione naturale dell'umidità
- Per calzature con fodera interna
- Bordo in tessuto morbido
- Struttura piqué



010*

255***

197***

49% Polyester (Coolmax®)
 30% Wolle (Merino) / Wool (Merino)
 12% Polyacryl
 7% Polypropylen
 1% Polyamid
 1% Elasthan (Lycra®)



XXL* – nur / only / seulement / solo col. 010/135
 *** – Limited Edition

Rohner	Europe	US Men's	US Women
S	36 - 38	3 - 5 1/2	4 1/2 - 6 1/2
M	39 - 41	6 - 8	7 1/2 - 9 1/2
L	42 - 44	8 1/2 - 10	10 - 11 1/2
XL	44 - 46	10 - 12	11+
XXL*	47 - 49	13 - 15	-

fibre tech

60.300/1

trek'n work



Cushion/Volume:



Season:



crew cut



123*



070*

115

255***

- Besonderheiten:**
- Weicher Abschlussrand
 - Der weiche Plüsch schützt vor Druckstellen am Rist
 - Plüsch im Fussbereich
 - Gekettelt

- Specificities:**
- Soft border
 - The soft terry prevents pressure spots on the instep
 - Terry construction in foot area
 - Seamless

- Particularités:**
- Bords non comprimants
 - La peluche moelleuse protège le cou-de-pied des zones de pression
 - Peluche dans la zone du pied
 - Remmaillée

- Particolarità:**
- Bordo in tessuto morbido
 - Il morbido tessuto in spugna evita punti di pressione nel collo del piede
 - Interno in tessuto felpato nella zona del piede
 - Punta rimagliata

- Hauptvorteil:**
- Spezielle Polsterung und gute Isolation

- Main Benefit:**
- Extra Cushioning and Warmth and good isolation

- Principal avantage:**
- Rembourrage et une isolation bonne

- Vantaggio principale:**
- Maggiore ammortizzamento e più calore

- Entwickelt für:**
- Schuhe mit Membranfutter

- Designed For:**
- Membrane Lined Boots

- Conçue pour:**
- Chaussures doublées en membrane

- Progettato per:**
- Scarponi con fodera interna

- Sport / Verwendung:**
- Rucksacktouren
 - Skating
 - Schneeschuhe
 - Wandern
 - Bergtouren
 - Jagen / Angeln
 - Arbeiten

- Sports / Use:**
- Backpacking
 - Trekking
 - Snowshoe
 - Skating
 - Hiking
 - Hunting / Fishing
 - Working

- Sports / Utilisations:**
- Grande randonnée
 - Patin à roulettes
 - Raquette
 - Trekking
 - L'alpinisme
 - Chasse / Pêche
 - Travail

- Sport / Uso:**
- Pattinaggio
 - Racchette da neve
 - Turismo con zaino
 - Trekking
 - Escursionismo
 - Caccia / Pesca
 - Lavoro

- Eigenschaften:**
- Plüsch im Fussbereich
 - Natürliche Feuchtigkeitsregulierung
 - Für Schuhe mit Membranfutter
 - Abriebfestigkeit
 - Weicher Abschlussrand

- Features:**
- Terry construction in foot area
 - Natural moisture management
 - For membran liner footwear
 - Wear resistance
 - Soft border

- Caractéristiques:**
- Peluche dans la zone du pied
 - Gestion naturelle de l'humidité
 - Pour chaussures doublées en membrane
 - Résistance
 - Bords non comprimants

- Caratteristiche:**
- Interno in tessuto felpato nella zona del piede
 - Gestione naturale dell'umidità
 - Per calzature con fodera interna
 - Resistenza all'usura
 - Bordo in tessuto morbido

40% Wolle (Merino) / Wool (Merino)
 39% Polyamid
 15% Polyester (Dacron®)
 4% Polypropylen
 2% Elasthan (Lycra®)



schoeller
 the spinning group

XXL* – nur / only / seulement / solo col. 070/123
 *** – Limited Edition

Rohner	Europe	US Men's	US Women
S	36 - 38	3 - 5 1/2	4 1/2 - 6 1/2
M	39 - 41	6 - 8	7 1/2 - 9 1/2
L	42 - 44	8 1/2 - 10	10 - 11 1/2
XL	44 - 46	10 - 12	11+
XXL*	47 - 49	13 - 15	-

original

60.309/1

trek'n work

Cushion/Volume:



Season:



crew cut



161



135*

114***

500***



Besonderheiten:

- Weicher Abschlussrand
- Extra dicker Plüsch aus reiner Wolle für Wanderschuhe mit Lederfutter
- Plüsch im Fussbereich



Specificities:

- Soft border
- Extra thick wool terry for hiking boots with leather linings
- Terry construction in foot area



Particularités:

- Bords non comprimants
- Peluche ultra-épaisse en pure laine pour les chaussures de randonnée à la doublure en cuir
- Peluche dans la zone du pied



Particolarità:

- Bordo in tessuto morbido
- Con spugna in lana di spessore maggiorato per scarponi da trekking con fodera in pelle
- Interno in tessuto felpato nella zona del piede

Hauptvorteil:

- Gute Isolation und Komfort

Entwickelt für:

- Schuhe mit Lederfutter

Sport / Verwendung:

- Rucksacktouren
- Wandern
- Bergtouren
- Jagen / Angeln
- Arbeiten
- Schneeschuhe

Eigenschaften:

- Plüsch im Fussbereich
- Gute Abriebfestigkeit
- Weicher Abschlussrand
- Natürliche Feuchtigkeitsregulierung

Main Benefit:

- Good isolation and Comfort

Designed For:

- Leather Lined Boots

Sports / Use:

- Backpacking
- Trekking
- Hiking
- Hunting / Fishing
- Working
- Snowshoe

Features:

- Terry construction in foot area
- Wear resistance
- Soft border
- Natural moisture management

Principal avantage:

- Isolation bonne et confort

Conçue pour:

- Chaussures doublées en cuir

Sports / Utilisations:

- Grande randonnée
- Trekking
- Randonnée pédestre
- Chasse / Pêche
- Travail
- Raquette

Caractéristiques:

- Peluche dans la zone du pied
- Résistance
- Bords non comprimants
- Gestion naturelle de l'humidité

Vantaggio principale:

- Comfort e calore

Progettato per:

- Scarponi con fodera in pelle

Sport / Uso:

- Racchette da neve
- Turismo con zaino
- Trekking Escursionismo
- Caccia / Pesca
- Lavoro

Caratteristiche:

- Interno in tessuto felpato nella zona del piede
- Resistenza all'usura
- Bordo in tessuto morbido
- Gestione naturale dell'umidità

70% Schurwolle / new wool
 25% Polyacryl
 3% Elasthan (Lycra®)
 2% Polyester (Trevira®)



schoeller
the spinning group



Rohner	Europe	US Men's	US Women
S	36 - 38	3 - 5 1/2	4 1/2 - 6 1/2
M	39 - 41	6 - 8	7 1/2 - 9 1/2
L	42 - 44	8 1/2 - 10	10 - 11 1/2
XL	44 - 46	10 - 12	11+
XXL*	47 - 49	13 - 15	

XXL* – nur / only / seulement / solo col. 135
 *** – Limited Edition

alpine trekking l/r

62.010/2

climate control

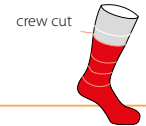

010



Besonderheiten:

- Weicher Abschlussrand
- Polsterzonen
- Rist- und Schienbeinpolsterung
- Gekettelt
- Asymetrischen Zehenbereich für perfekte Passform



Specificities:

- Soft border
- Terry construction
- Instep and shinbone cushioning
- Seamless
- Asymmetrical toe area for a perfect fit



Particularités:

- Bord non comprimant
- Construction peluche
- Rembourrage cou-de-pied et tibia
- Remmaillée
- Asymétrie au niveau des orteils pour un parfait



Particolarità:

- Bordo in tessuto
- Struttura in spugna
- Imbottitura nella zone del collo del piede e dello stinco
- Punta rimagliata
- Area anteriore del piede asimmetrica per una calzata perfetta

Hauptvorteil:

- Wärme- und Temperaturregulierung

Entwickelt für:

- Extreme 4000 m +

Sport / Verwendung:

- Eisklettern
- Rucksacktouren
- Wandern
- Jagen / Angeln
- Einsatzteam

Eigenschaften:

- Antibakteriell
- Geruchshemmend
- Antistatisch
- Ristpolsterung
- Schienbeinschutz
- Vollplüschsocke
- Natürliche Thermoregulierung
- Abriebfestigkeit
- Weicher Abschlussrand
- Anatomische Passform

Main Benefit:

- Warmth and Temperature Control

Designed For:

- Extreme 4000 m +

Sports / Use:

- Ice Climbing
- Backpacking
- Trekking
- Hunting / Fishing
- Task Force

Features:

- Antibacterial
- Anti-odor
- Antistatic
- Instep protection
- Shinbone protection
- Full terry construction
- Natural thermo control
- Wear resistance
- Soft border
- Anatomical fit

Principal avantage:

- Régulation de la chaleur et la temperature

Conçue pour:

- Randonnée extrême 4000 m +

Sports / Utilisations:

- Escalade de glace
- Grande randonnée
- Trekking
- Chasse / Pêche
- Force opérationnelle

Caractéristiques:

- Antibactérienne
- Anti-odeur
- Antistatique
- Protection du cou-de-pied
- Protection du tibia
- Construction pleine peluche
- Régulation thermique naturelle
- Résistance
- Bords non comprimants
- Une forme anatomique

Vantaggio principale:

- Calore e termoregolazione

Progettato per:

- Quote estreme +4000 m

Sport / Uso:

- Arrampicata su ghiaccio
- Turismo con zaino
- Trekking
- Caccia / Pesca
- Task force

Caratteristiche:

- Antibatterico
- Antiodore
- Antistatico
- Protezione del collo del piede
- Protezione dello stinco
- Struttura interamente in spugna
- Termoregolazione naturale
- Resistenza all'usura
- Bordo in tessuto morbido
- Calzata anatomica

39% Polyacryl (Outlast®)
 24% Polyacryl
 14% Schurwolle / new wool
 12% Polyamid
 10% PTFE (Profilen®)
 1% Elasthan (Lycra®)



Rohner	Europe	US Men's	US Women
S	36 - 38	3 - 5 1/2	4 1/2 - 6 1/2
M	39 - 41	6 - 8	7 1/2 - 9 1/2
L	42 - 44	8 1/2 - 10	10 - 11 1/2
XL	44 - 46	10 - 12	11+

expedition

60.179/2

max. warmth



Cushion/Volume:



Season:



high crew

**Besonderheiten:**

- Wärmeschild
- Vollplüschsocke
- Verstärkte Hochferse und Spitze mit Profilen®
- Rohner Air Channel-System im Ristbereich
- Gekettelt

Hauptvorteil:

- Maximale Wärme

Entwickelt für:

- Extreme 6000 m +

Sport / Verwendung:

- Expeditionen
- Hochgebirgstouren
- Eisklettern

Eigenschaften:

- Antibakteriell
- Geruchshemmend
- Antistatisch
- Vollplüschsocke
- Natürliche Thermoregulierung
- Abriebfestigkeit
- Doppelschicht Konstruktion

Specificities:

- Warmth shield
- Full terry construction
- Reinforced high heel and toe with Profilen®
- Rohner Air Channel System in instep area
- Seamless

Main Benefit:

- Maximum Warmth

Designed For:

- Extreme 6000 m +

Sports / Use:

- Expeditions
- Mountain tours
- Ice Climbing

Features:

- Antibacterial
- Anti-odor
- Antistatic
- Full terry construction
- Natural thermo control
- Wear resistance
- Double face construction

Particularités:

- Bouclier thermique
- Construction pleine peluche
- Talons prolongé et pointes renforcé avec de fibres Profilen®
- Circulation de l'air optimisée au niveau du cou-de-pied par le Rohner Air Channel System
- Zone des orteils remmaillée

Principal avantage:

- Chaleur maximale

Conçue pour:

- Randonnée extrême 6000 m +

Sports / Utilisations:

- Expéditions
- Randonnées / courses en haute montagne
- Escalade de glace

Caractéristiques:

- Antibactérienne
- Anti-odeur
- Antistatique
- Construction pleine peluche
- Régulation thermique naturelle
- Résistance
- Construction double face

Particolarità:

- Mantiene il piede caldo
- Struttura interamente in spugna
- Tallone rialzato rinforzato e punta rinforzata con Profilen®
- Sistema Rohner Air Channel System nel collo del piede
- Punta rimagliata

Vantaggio principale:

- Massimo calore

Progettato per:

- Quote estreme 6000 m +

Sport / Uso:

- Spedizioni
- Tour in alta montagna
- Arrampicata su ghiaccio

Caratteristiche:

- Antibatterico
- Antiodore
- Antistatico
- Struttura interamente in spugna
- Termoregolazione naturale
- Resistenza all'usura
- Struttura reversibile

48% Wolle (Merino) / Wool (Merino)
 22% Polyamid
 18% Seide / Silk
 7% PTFE (Profilen®)
 4% Silber / Silver
 1% Elasthan (Lykra®)

PROFLEN
sportswear



silver

Rohner	Europe	US Men's	US Women
S	36 - 38	3 - 5½	4½ - 6½
M	39 - 41	6 - 8	7½ - 9½
L	42 - 44	8½ - 10	10 - 11½
XL	44 - 46	10 - 12	11+

compression outdoor light

60.250/3

energy socks

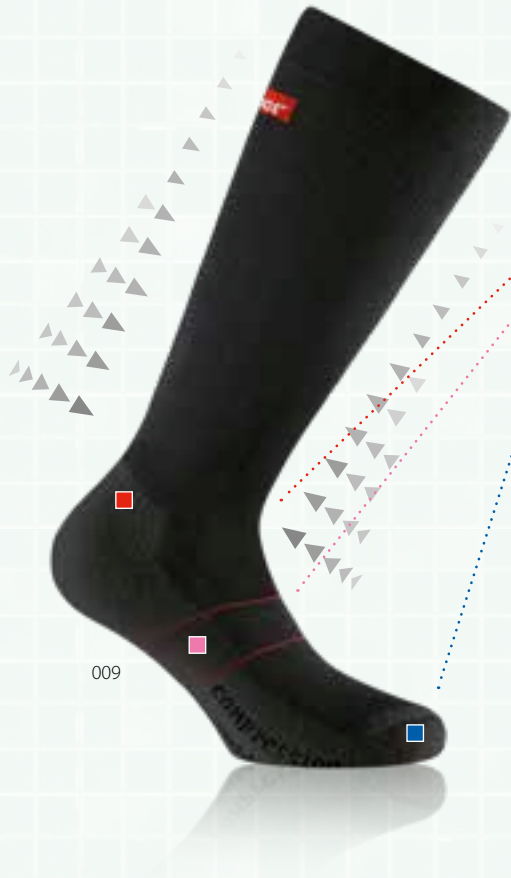

Cushion/Volume:



Season:



over the calf



- Besonderheiten:**
- Verstärkte Hochferse
 - Plüsch im Fussbereich
 - Gekettelt

- Specificities:**
- Strengthened high-heel
 - Terry construction in foot area
 - Seamless

- Particularités:**
- Haut du talon renforcé
 - Peluche dans la zone du pied
 - Remmaillée

- Particolarità:**
- Tallone rinforzato di altezza maggiorata
 - Interno in tessuto felpato nella zona del piede
 - Punta rimagliata

- Hauptvorteil:**
- Verbesserte Durchblutung
 - Entspannung der Muskulatur
 - Verbesserte Regenerationsfähigkeit
 - Entsäuerung der Muskulatur

- Entwickelt für:**
- Outdoor

- Sport / Verwendung:**
- Rucksacktouren
 - Wandern
 - Bergtouren

- Eigenschaften:**
- Temperaturkontrolle
 - Verbesserte arterielle Durchblutung im Bein
 - Antibakteriell
 - Geruchshemmend
 - Fuss mit MerylSkinlife®
 - Rohr und Fuss mit Polyester Biokeramik

- Main Benefit:**
- Improved circulation
 - Relaxing muscles
 - Improved ability to regenerate
 - Acidification of the muscles

- Designed For:**
- All Outdoor

- Sports / Use:**
- Backpacking
 - Trekking
 - Hiking

- Features:**
- Thermo control
 - Improved arterial circulation in the legs
 - Antibacterial
 - Anti-odor
 - Foot with MerylSkinlife®
 - Tube and foot with Polyester Bioceramic

- Principal avantage:**
- Amélioration de la circulation du sang
 - Relaxation de la musculature
 - Amélioration de la capacité de régénération
 - Désacidification de la musculature

- Conçue pour:**
- Tous les sports et activités de plein air

- Sports / Utilisations:**
- Grande randonnée
 - Trekking
 - Randonnée pédestre

- Caractéristiques:**
- Régulation thermique
 - Amélioration de la circulation artérielle dans la jambe
 - Antibactérienne
 - Anti-odeur
 - Pied avec MerylSkinlife®
 - Tube et pied avec Polyester Bioceramic

- Vantaggio principale:**
- Miglioramento della circolazione del sangue
 - Rilassamento della muscolatura
 - Maggiore capacità di rigenerazione muscolare
 - Disacidificazione dei muscoli

- Progettato per:**
- Tutti gli ambienti esterni

- Sport / Uso:**
- Turismo con zaino
 - Trekking
 - Escursionismo

- Caratteristiche:**
- Termoregolante
 - Migliora la circolazione arteriosa della gamba
 - Antibatterico
 - Antiodore
 - Piede con MerylSkinlife®
 - Tubo et piede con Poliestere Bioceramica

43% Polyester Biokeramik / Bioceramic
 28% Polyamid
 17% Polyamid (MerylSkinlife®)
 8% Wolle (Merino) / Wool (Merino)
 2% Polyacryl
 2% Elasthan (Lycra®)



Rohner	Europe	US Men's	US Women
S	36 - 38	3 - 5 1/2	4 1/2 - 6 1/2
M	39 - 41	6 - 8	7 1/2 - 9 1/2
L	42 - 44	8 1/2 - 10	10 - 11 1/2
XL	44 - 46	10 - 12	11+

protector plus

10.004/1

first layer sock

Unterziehsöcke
First Layer Sock
Sous-chaussettes
IT Sottocalza

Season:



crew cut



009

**Besonderheiten:**

- Weicher Abschlussrand
- Gekettelt

**Specificities:**

- Soft border
- Seamless

**Particularités:**

- Bords non comprimants
- Remmaillée

**Particolarità:**

- Bordo in tessuto morbido
- Punta rimagliata

Hauptvorteil:

- Hautschutz und Feuchtigkeitstransport

Sport / Verwendung:

- Unterziehsöcke

Main Benefit:

- Skin protection and moisture transport

Sports / Use:

- First Layer Sock

Principal avantage:

- Protection de la peau et transport de transpiration

Sports / Utilisations:

- Sous-chaussettes

Vantaggio principale:

- Protezione della pelle e drenaggio dell'umidità

Sport / Uso:

- IT Sottocalza

100% Polypropylen

Rohner	Europe	US Men's	US Women
S	36 - 38	3 - 5½	4½ - 6½
M	39 - 41	6 - 8	7½ - 9½
L	42 - 44	8½ - 10	10 - 11½
XL	44 - 46	10 - 12	11+



Work + Army

Einsatzfähig trotz hoher Belastung

fibre light superR

60.039/1
Trekking

Seite 37



protector plus

10.004/1
Trekking

Seite 47



working light

40.020/2
Working

Seite 66



army / working

40.030/2
Working

Seite 67



Running

der Weg ist das Ziel



r-ultra light

60.261/2



Cushion/Volume:



Season:



low cut

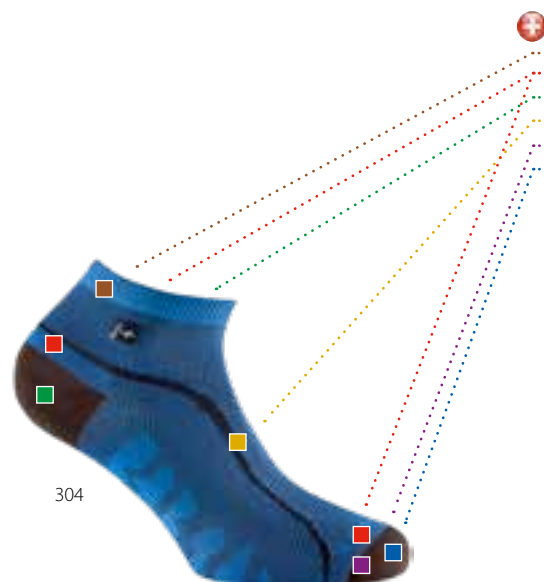

Besonderheiten:

- Rutschfester Abschlussrand
- Verstärker Fersen und Zehenbereich mit Lenofil
- Y-Ferse für perfekten Sitz
- Pique Struktur
- Anatomischer Zehenbereich
- Gekettelt



Specificities:

- Anti slip border
- Reinforcement in heel and toe with Lenofil
- Y-heel for perfect fit
- Pique structure
- Anatomical toe
- Seamless



Particularités:

- Bords antidérapants
- Renforcement du talon et des orteils avec Lenofil
- Talon en Y pour ajustement parfait
- Structure de piqué
- Forme anatomique de la zone des orteils
- Remmaillée



Particolarità:

- Bordo antiscivolo
- Rinforzo nell'area del tallone e della punta con Lenofil
- Tallone a Y per una calzata perfetta
- Struttura piqué
- Forma anatomica della punta
- Punta rimagliata

Hauptvorteil:

- Leicht und dünn
- Feuchtigkeitsregulierung

Main Benefit:

- Light and thin
- Moisture management

Principal avantage:

- Léger et fin
- Gestion de l'humidité

Vantaggio principale:

- Leggero e sottile
- Gestione dell'umidità

Entwickelt für:

- Direkter Schuhkontakt
- Perfekte Passform

Designed For:

- Close shoe contact
- Perfect fit

Conçue pour:

- Exposition directe avec la chaussure
- Ajustement parfait

Progettato per:

- Aderenza alla calzatura
- Calzata perfetta

Sport / Verwendung:

- Aktive Sportarten
- Geländelauf
- Joggen
- Laufen
- Radfahren
- Hallensport

Sports / Use:

- Active sports
- Trail Running
- Running
- Walking
- Biking
- Indoor

Sports / Utilisations:

- Sports actifs
- Course sur sentier
- Course à pied
- Marche
- Cyclisme
- Sports en salle

Sport / Uso:

- Sport dinamici
- Corsa in natura
- Corsa
- Marcia
- Ciclismo
- Ambienti interni

Eigenschaften:

- Leicht und dünn
- Antibakteriell
- Für Schuhe mit Membranfutter
- Vermeidet Blasenbildung

Features:

- Light and thin
- Antibacterial
- For membrane liner footwear
- Reduces blistering

Caractéristiques:

- Léger et fin
- Antibactérienne
- Pour chaussures doublées en membrane
- Réduit les ampoules

Caratteristiche:

- Leggero e sottile
- Antibatterico
- Per calzature con fodera interna
- Riduce la formazione di vesciche



32% Polyamid
 22% Polyamid (Meryl Skinlife®)
 22% Polyamid (Tactel®)
 22% PTFE (Profilen®)
 2% Elasthan (Lycra®)



Rohner	Europe	US Men's	US Women
S**	36 - 38	3 - 5 1/2	4 1/2 - 6 1/2
M**	39 - 41	6 - 8	7 1/2 - 9 1/2
L	42 - 44	8 1/2 - 10	10 - 11 1/2
XL	44 - 46	10 - 12	11+
XXL	47 - 48	12 1/2 - 13	

** - col. 141 nur / only / seulement in S und M
 *** - Limited Edition

r-power light l/r

62.234/0



Cushion/Volume:



Season:



low cut



Besonderheiten:

- Rohner Air Channel-System im Fussbereich
- Pique-Struktur
- Plüsch in Spitze und Ferse
- Gekettelt



Specificities:

- Rohner Air Channel System in foot area
- Piqué structure
- High-heel and toe cushioning
- Seamless



Particularités:

- Circulation de l'air optimisée par le Rohner Air Channel System
- Structure de piqué
- Rembourrage au niveau des talons et orteils
- Remmaillée



Particolarità:

- Sistema Rohner Air Channel System nell'area del piede
- Struttura piqué
- Imbottitura nella punta e nel Tallone
- Punta rimagliata



174*

Hauptvorteil:

- Atmungsaktiv

Main Benefit:

- Breathability

Principal avantage:

- Respirabilité

Vantaggio principale:

- Traspirazione

Entwickelt für:

- Aktive Sportarten

Designed For:

- Active sports

Conçue pour:

- Sports actifs

Progettato per:

- Sport dinamici

Sport / Verwendung:

- Geländelauf
- Joggen
- Laufen
- Radfahren
- Hallensport

Sports / Use:

- Trail Running
- Running
- Walking
- Biking
- Indoor

Sports / Utilisations:

- Course sur sentier
- Course à pied
- Marche
- Cyclisme
- Sports en salle

Sport / Uso:

- Corsa in natura
- Corsa
- Marcia
- Ciclismo
- Ambienti interni

Eigenschaften:

- Antibakteriell
- Geruchshemmend
- Antistatisch
- Für Schuhe mit Membranfutter
- Anatomische Passform

Features:

- Antibacterial
- Anti-odor
- Antistatic
- For membran liner footwear
- Anatomical fit

Caractéristiques:

- Antibactérienne
- Anti-odeur
- Antistatique
- Pour chaussures doublées en membrane
- Forme anatomique

Caratteristiche:

- Antibatterico
- Antiodore
- Antistatico
- Per calzature con fodera interna
- Calzata anatomica



141**

65% Polyamid (MerylSkinlife®)
25% Polyamid
10% Elasthan (Lycra®)



* – nur / only / seulment / solo col. 174
** – nur / only / seulment / solo col. 141

Rohner	Europe	US Men's
S**	36 - 38	4 1/2 - 6 1/2
M**	39 - 41	6 - 8
L	42 - 44	8 1/2 - 10
XL	44 - 46	10 - 12
XXL*	47 - 49	13 - 15

r-power l/r

62.230/1

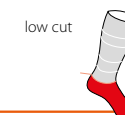

174*

141**/**



Besonderheiten:

- Rohner Air Channel-System im Fussbereich
- Pique-Struktur
- Plüsch im Fussbereich
- Gekettelt



Specificities:

- Rohner Air Channel System in foot area
- Piqué structure
- Terry construction in foot area
- Seamless



Particularités:

- Circulation de l'air optimisée par le Rohner Air Channel System
- Structure de piqué
- Peluche dans la zone du pied
- Remmaillée



Particolarità:

- Sistema Rohner Air Channel System nell'area del piede
- Struttura piqué
- Interno in tessuto felpato nella zona del piede
- Punta rimagliata

Hauptvorteil:

- Atmungsaktiv

Entwickelt für:

- Aktive Sportarten

Sport / Verwendung:

- Geländelauf
- Joggen
- Laufen
- Radfahren
- Hallensport

Eigenschaften:

- Antibakteriell
- Geruchshemmend
- Antistatisch
- Plüsch im Fussbereich
- Für Schuhe mit Membranfutter
- R.A.C.S.
- Anatomische Passform
- Pique-Struktur

Main Benefit:

- Breathability

Designed For:

- Active sports

Sports / Use:

- Trail Running
- Running
- Walking
- Biking
- Indoor

Features:

- Antibacterial
- Anti-odor
- Antistatic
- Terry construction in foot area
- For membran liner footwear
- R.A.C.S.
- Anatomical fit
- Piqué structure

Principal avantage:

- Respirabilité

Conçue pour:

- Sports actifs

Sports / Utilisations:

- Course sur sentier
- Course à pied
- Marche
- Cyclisme
- Sports en salle

Caractéristiques:

- Antibactérienne
- Anti-odeur
- Antistatique
- Peluche dans la zone du pied
- Pour chaussures doublées en membrane
- R.A.C.S.
- Forme anatomique
- Structure de piqué

Vantaggio principale:

- Traspirazione

Progettato per:

- Sport dinamici

Sport / Uso:

- Corsa in natura
- Corsa
- Marcia
- Ciclismo
- Ambienti interni

Caratteristiche:

- Antibatterico
- Antiodore
- Antistatico
- Interno in tessuto felpato nella zona del piede
- Per calzature con fodera interna
- Sistema R.A.C.S.
- Calzata anatomica
- Struttura piqué

65% Polyamid (MerylSkinlife®)
25% Polyamid
10% Elasthan (Lycra®)



XXL* – nur / only / seulment / solo col. 174
S und M** – nur / only / seulment / solo col. 141
*** – Limited Edition

Rohner	Europe	US Men's
S**	36 - 38	4 1/2 - 6 1/2
M**	39 - 41	6 - 8
L	42 - 44	8 1/2 - 10
XL	44 - 46	10 - 12
XXL*	47 - 49	13 - 15

r-power quarter l/r

62.232/1



Cushion/Volume:



Season:



1/4 crew



174



Besonderheiten:

- Rohner Air Channel-System im Fussbereich
- Pique-Struktur
- Plüsch im Fussbereich
- Gekettelt



Specificities:

- Rohner Air Channel System in foot area
- Piqué structure
- Terry construction in foot area
- Seamless



Particularités:

- Circulation de l'air optimisée par le Rohner Air Channel System
- Structure de piqué
- Peluche dans la zone du pied
- Remmaillée



Particolarità:

- Sistema Rohner Air Channel System nell'area del piede
- Struttura piqué
- Interno in tessuto felpato nella zona del piede
- Punta rimagliata

Hauptvorteil:

- Atmungsaktiv

Main Benefit:

- Breathability

Principal avantage:

- Respirabilité

Vantaggio principale:

- Traspirazione

Entwickelt für:

- Aktive Sportarten

Designed For:

- Active sports

Conçue pour:

- Sports actifs

Progettato per:

- Sport dinamici

Sport / Verwendung:

- Geländelauf
- Joggen
- Laufen
- Radfahren
- Hallensport

Sports / Use:

- Trail Running
- Running
- Walking
- Biking
- Indoor

Sports / Utilisations:

- Course sur sentier
- Course à pied
- Marche
- Cyclisme
- Sports en salle

Sport / Uso:

- Corsa in natura
- Corsa
- Marcia
- Ciclismo
- Ambienti interni

Eigenschaften:

- Antibakteriell
- Geruchshemmend
- Antistatisch
- Plüsch im Fussbereich
- Für Schuhe mit Membranfutter
- R.A.C.S.
- Anatomische Passform
- Pique-Struktur

Features:

- Antibacterial
- Anti-odor
- Antistatic
- Terry construction in foot area
- For membran liner footwear
- R.A.C.S.
- Anatomical fit
- Piqué structure

Caractéristiques:

- Antibactérienne
- Anti-odeur
- Antistatique
- Peluche dans la zone du pied
- Pour chaussures doublées en membrane
- R.A.C.S.
- Forme anatomique
- Structure de piqué

Caratteristiche:

- Antibatterico
- Antiodore
- Antistatico
- Interno in tessuto felpato nella zona del piede
- Per calzature con fodera interna
- Sistema R.A.C.S.
- Calzata anatomica
- Struttura piqué

65% Polyamid (MerylSkinlife®)
25% Polyamid
10% Elasthan (Lycra®)



Rohner	Europe	US Men's
S	36 - 38	4 1/2 - 6 1/2
M	39 - 41	6 - 8
L	42 - 44	8 1/2 - 10
XL	44 - 46	10 - 12
XXL	47 - 49	13 - 15

silver runner l/r II

62.098/1

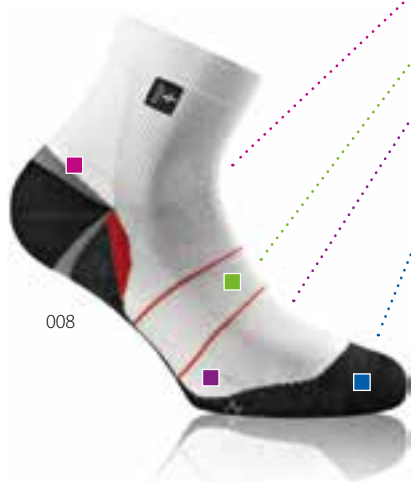
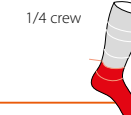

008



009

- Besonderheiten:**
- Gepolsterte Hochferse
 - Elastzone für besseren Halt
 - Polsterzone mit Silberfasern im Fussbereich
 - Gekettelt

- Specificities:**
- Padded Achilles' heel
 - Elastic zone for improved support
 - Terry construction with silver fibre in foot area
 - Seamless

- Particularités:**
- Talon haut rembourré
 - Zone élastique pour un meilleur maintien
 - Semelle en peluche mêlée de fibres d'argent
 - Remmaillée

- Particolarità:**
- Tallone d'Achille rivestito
 - Zona elastica per un supporto migliorato
 - Struttura in spugna con fibra d'argento nell'area del piede
 - Punta rimagliata

- Hauptvorteil:**
- Antibakteriell und komfortabel

- Main Benefit:**
- Antibacterial and comfortable

- Principal avantage:**
- Antibactérienne et confortable

- Vantaggio principale:**
- Azione antibatterica e confort

- Entwickelt für:**
- Tägliches Joggen

- Designed For:**
- Daily Running

- Conçue pour:**
- Course à pied quotidienne

- Progettato per:**
- Jogging

- Sport / Verwendung:**
- Geländelauf
 - Joggen
 - Laufen
 - Hallensport
 - Wandern

- Sports / Use:**
- Trail Running
 - Running
 - Walking
 - Indoor
 - Hiking

- Sports / Utilisations:**
- Course sur sentier
 - Course à pied
 - Marche
 - Sports en salle
 - Randonnée pédestre

- Sport / Uso:**
- Corsa in natura
 - Corsa
 - Marcia
 - Ambienti interni
 - Escursionismo

- Eigenschaften:**
- Antibakteriell
 - Geruchshemmend
 - Antistatisch
 - Plüsch im Fussbereich
 - Natürliche Feuchtigkeitsregulierung
 - Für Schuhe mit Membranfutter
 - Anatomische Passform

- Features:**
- Antibacterial
 - Anti-odor
 - Antistatic
 - Terry construction in foot area
 - Natural moisture management
 - For membran liner footwear
 - Anatomical fit

- Caractéristiques:**
- Antibactérienne
 - Anti-odeur
 - Antistatique
 - Peluche dans la zone du pied
 - Gestion naturelle de l'humidité
 - Pour chaussures doublées en membrane
 - Forme anatomique

- Caratteristiche:**
- Antibatterico
 - Antiodore
 - Antistatico
 - Interno in tessuto felpato nella zona del piede
 - Gestione naturale dell'umidità
 - Per calzature con fodera interna
 - Calzata anatomica

40% Polyester (Dacron®)
 33% Baumwolle / cotton
 12% Polyester
 10% Polyamid
 4% Silber Faser / silver fibre
 1% Elasthan (Lycra®)



Rohrer	Europe	US Men's	US Women
S	36 - 38	3 - 5 1/2	4 1/2 - 6 1/2
M	39 - 41	6 - 8	7 1/2 - 9 1/2
L	42 - 44	8 1/2 - 10	10 - 11 1/2
XL	44 - 46	10 - 12	11+

compression r-power l/r

62.245/3

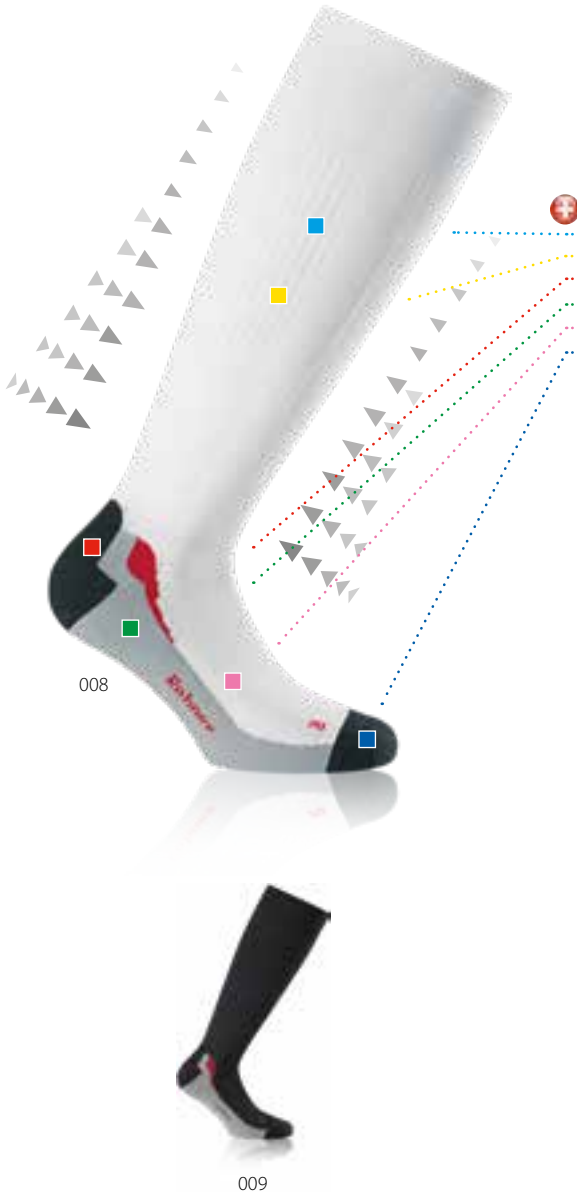

Cushion/Volume:



Season:



over the calf



- Besonderheiten:**
- Luftkanäle
 - Degressiver Druckverlauf
 - Verstärkte Hochferse
 - Rohner Air Channel-System
 - Plüsch im Fussbereich
 - Gekettelt

- Specificities:**
- Air channels
 - Demeinishing pressure
 - High heel reinforcement
 - Rohner Air Channel System
 - Terry construction in foot area
 - Seamless

- Particularités:**
- Canaux d'aération
 - Compression dégressive
 - Haut du talon renforcé
 - Circulation de l'air optimisée par le Rohner Air Channel System
 - Peluche dans la zone du pied
 - Remmaillée

- Particolarità:**
- Canali per il passaggio dell'aria
 - Tecnologia a pressione degressiva
 - Parte alta del tallone rinforzata
 - Sistema Rohner Air Channel System
 - Interno in tessuto felpato nella zona del piede
 - Punta rimagliata

- Hauptvorteil:**
- Kompression, Atmungsaktivität, Polsterung

- Entwickelt für:**
- Laufsport / Aktive Sportarten

- Sport / Verwendung:**
- Joggen
 - Laufen
 - Hallensport

- Eigenschaften:**
- Verbesserte arterielle Durchblutung im Bein
 - Antibakteriell
 - Geruchshemmend
 - Antistatisch
 - Plüsch im Fussbereich
 - Für Schuhe mit Membranfutter
 - R.A.C.S.
 - Anatomische Passform
 - Pique-Struktur
 - Kompression

- Main Benefit:**
- Compression, Breathability, Cushioning

- Designed For:**
- For running / Active Sports

- Sports / Use:**
- Running
 - Walking
 - Indoor

- Features:**
- Improved arterial circulation in the legs
 - Antibacterial
 - Anti-odor
 - Antistatic
 - Terry construction in foot area
 - For membran liner footwear
 - R.A.C.S.
 - Anatomical fit
 - Pique structure
 - Compression

- Principal avantage:**
- Compression, respirabilité, rembourrage

- Conçue pour:**
- Course à pied / Sports et activités de plein air / Loisirs

- Sports / Utilisations:**
- Course à pied
 - Marche
 - Sports en salle

- Caractéristiques:**
- Amélioration de la circulation artérielle dans la jambe
 - Antibactérienne
 - Anti-odeur
 - Antistatique
 - Peluche dans la zone du pied
 - Pour chaussures doublées en membrane
 - R.A.C.S.
 - Forme anatomique
 - Structure de piqué
 - Compression

- Vantaggio principale:**
- Compressione, traspirazione, ammortizzamento

- Progettato per:**
- Corsa sportiva e running / esterni attività ricreative

- Sport / Uso:**
- Corsa
 - Marcia
 - Ambienti interni

- Caratteristiche:**
- Migliora la circolazione arteriosa della gamba
 - Antibatterico
 - Antiodore
 - Antistatico
 - Interno in tessuto felpato nella zona del piede
 - Per calzature con fodera interna
 - Sistema R.A.C.S.
 - Calzata anatomica
 - Struttura piqué
 - Compressione

44% Polyamid (Tactel®)
27% Polyamid
22% Polyamid (MerylSkinlife®)
7% Elasthan (Lycra®)



Rohner	Europe	US Men's	US Women
S	36 - 38	3 - 5 1/2	4 1/2 - 6 1/2
M	39 - 41	6 - 8	7 1/2 - 9 1/2
L	42 - 44	8 1/2 - 10	10 - 11 1/2
XL	44 - 46	10 - 12	11+

r-ultra light

60.261/2
Running

Seite 51



r-power light l/r

62.234/0
Running

Seite 52



r-power l/r

62.230/1
Running

Seite 53



r-power quarter l/r

62.232/1
Running

Seite 54



Compression R-Power

62.245/3
Compression

Seite 56

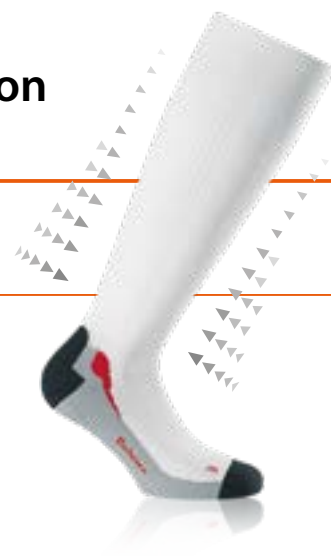

Cross Sports

bereit für jede Herausforderung



copper allsport sneaker

60.263/0

Cushion/Volume:



Season:



low cut

**Besonderheiten:**

- Elastzone
- Gekettelt

**Specificities:**

- Elastic zone
- Seamless

**Particularités:**

- Zone élastique
- Remmaillée

**Particolarità:**

- Zona elastica
- Punta rimagliata



009

Hauptvorteil:

- Mildert Hautprobleme an Füßen (Anti-Fusspilz)
- Maximaler Fusskomfort

Entwickelt für:

- Hautprobleme an Füßen
- Trockene Füße

Sport / Verwendung:

- Alltagsgebrauch
- Aktive Sportarten
- Geländelauf
- Joggen
- Laufen
- Radfahren
- Hallensport

Eigenschaften:

- Antibakteriell
- Antimykotisch
- Geruchshemmend
- Hautfreundlich
- Mildert Hautrötungen, Fissuren, Bläschenbildung, Schuppen, Juckreiz

Main Benefit:

- Attenuates the skin problems of the feet (antifungal)
- Maximum comfort for the feet

Designed For:

- Skin problems on the feet
- Dry feet

Sports / Use:

- Daily use
- Active Sports
- Trail Running
- Running
- Walking
- Biking
- Indoor

Features:

- Antibacterial
- Antifungal
- Anti-odor
- Gentle for the skin
- Reduces redness, cracks, blisters, dandruff, burns and itching of the skin

Principal avantage:

- Atténue les problèmes de peau des pieds (antifongique)
- Comfort maximum des pieds

Conçue pour:

- Problèmes de peau aux pieds
- Pieds secs

Sports / Utilisations:

- Utilisation quotidienne
- Sports actifs
- Course sur sentier
- Course à pied
- Marche
- Cyclisme
- Sports en salle

Caractéristiques:

- Antibactérienne
- Antifongique
- Anti-odeur
- Doux pour la peau
- Atténue les rougeurs, les crevasses, les cloques, les pellicules et les démangeaisons de la peau

Vantaggio principale:

- Attenua i problemi per pelli delicate (anti-fungine)
- Massimo conforto del piede

Progettato per:

- Problemi di pelle ai piedi
- Piedi con pelle disidratata

Sport / Uso:

- Uso quotidiano
- Sport dinamici
- Corsa in natura
- Corsa
- Marcia
- Ciclismo
- Ambienti interni

Caratteristiche:

- Antibatterico
- Antimicotico
- Antiodore
- Delicato sulla pelle
- Attenua gli arrossamenti, le screpolature, la formazione di vesciche, la desquamazione e il prurito

50% Polypropylen
26% Polyamid
21% Cupron (Kupfer-Polyamid)
3% Elasthan



Rohner	Europe	US Men's	US Women
S	36 - 38	3 - 5½	4½ - 6½
M	39 - 41	6 - 8	7½ - 9½
L	42 - 44	8½ - 10	10 - 11½
XL	44 - 46	10 - 12	11+
XXL	47 - 48	12½ - 13	

copper allsport quarter

60.263/2

Cushion/Volume:



Season:



1/4 crew



009

Besonderheiten:

- Elastzone
- Gekettelt

Specificities:

- Elastic zone
- Seamless

Particularités:

- Zone élastique
- Remmaillée

Particolarità:

- Zona elastica
- Punta rimagliata

Hauptvorteil:

- Mildert Hautprobleme an Füßen (Anti-Fusspilz)
- Maximaler Fusskomfort

Entwickelt für:

- Hautprobleme an Füßen
- Trockene Füße

Sport / Verwendung:

- Alltagsgebrauch
- Aktive Sportarten
- Geländelauf
- Joggen
- Laufen
- Radfahren
- Hallensport

Eigenschaften:

- Antibakteriell
- Antimykotisch
- Geruchshemmend
- Hautfreundlich
- Mildert Hautrötungen, Fissuren, Bläschenbildung, Schuppen, Juckreiz

Main Benefit:

- Attenuates the skin problems of the feet (antifungal)
- Maximum comfort for the feet

Designed For:

- Skin problems on the feet
- Dry feet

Sports / Use:

- Daily use
- Active Sports
- Trail Running
- Running
- Walking
- Biking
- Indoor

Features:

- Antibacterial
- Antifungal
- Anti-odor
- Gentle for the skin
- Reduces redness, cracks, blisters, dandruff, burns and itching of the skin

Principal avantage:

- Atténue les problèmes de peau des pieds (antifongique)
- Comfort maximum des pieds

Conçue pour:

- Problèmes de peau aux pieds
- Pieds secs

Sports / Utilisations:

- Utilisation quotidienne
- Sports actifs
- Course sur sentier
- Course à pied
- Marche
- Cyclisme
- Sports en salle

Caractéristiques:

- Antibactérienne
- Antifongique
- Anti-odeur
- Doux pour la peau
- Atténue les rougeurs, les crevasses, les cloques, les pellicules et les démangeaisons de la peau

Vantaggio principale:

- Attenua i problemi per pelli delicate (anti-fungine)
- Massimo conforto del piede

Progettato per:

- Problemi di pelle ai piedi
- Piedi con pelle disidratata

Sport / Uso:

- Uso quotidiano
- Sport dinamici
- Corsa in natura
- Corsa
- Marcia
- Ciclismo
- Ambienti interni

Caratteristiche:

- Antibatterico
- Antimicotico
- Antiodore
- Delicato sulla pelle
- Attenua gli arrossamenti, le screpolature, la formazione di vesciche, la desquamazione e il prurito

48% Polypropylen
27% Polyamid
22% Cupron (Kupfer-Polyamid)
3% Elasthan



Rohrer	Europe	US Men's	US Women
S	36 - 38	3 - 5 1/2	4 1/2 - 6 1/2
M	39 - 41	6 - 8	7 1/2 - 9 1/2
L	42 - 44	8 1/2 - 10	10 - 11 1/2
XL	44 - 46	10 - 12	11+
XXL	47 - 48	12 1/2 - 13	

copper allsport

60.263/1

Cushion/Volume:



Season:



crew cut

**Besonderheiten:**

- Elastzone
- Gekettelt

Specificities:

- Elastic zone
- Seamless

Particularités:

- Zone élastique
- Remmaillée

Particolarità:

- Zona elastica
- Punta rimagliata

Hauptvorteil:

- Mildert Hautprobleme an Füßen (Anti-Fusspilz)
- Maximaler Fusskomfort

Entwickelt für:

- Hautprobleme an Füßen
- Trockene Füße

Sport / Verwendung:

- Alltagsgebrauch
- Aktive Sportarten
- Geländelauf
- Joggen
- Laufen
- Radfahren
- Hallensport

Eigenschaften:

- Antibakteriell
- Antimykotisch
- Geruchshemmend
- Hautfreundlich
- Mildert Hautrötungen, Fissuren, Bläschenbildung, Schuppen, Juckreiz

Main Benefit:

- Attenuates the skin problems of the feet (antifungal)
- Maximum comfort for the feet

Designed For:

- Skin problems on the feet
- Dry feet

Sports / Use:

- Daily use
- Active Sports
- Trail Running
- Running
- Walking
- Biking
- Indoor

Features:

- Antibacterial
- Antifungal
- Anti-odor
- Gentle for the skin
- Reduces redness, cracks, blisters, dandruff, burns and itching of the skin

Principal avantage:

- Atténue les problèmes de peau des pieds (antifongique)
- Comfort maximum des pieds

Conçue pour:

- Problèmes de peau aux pieds
- Pieds secs

Sports / Utilisations:

- Utilisation quotidienne
- Sports actifs
- Course sur sentier
- Course à pied
- Marche
- Cyclisme
- Sports en salle

Caractéristiques:

- Antibactérienne
- Antifongique
- Anti-odeur
- Doux pour la peau
- Atténue les rougeurs, les crevasses, les cloques, les pellicules et les démangeaisons de la peau

Vantaggio principale:

- Attenua i problemi per pelli delicate (anti-fungine)
- Massimo conforto del piede

Progettato per:

- Problemi di pelle ai piedi
- Piedi con pelle disidratata

Sport / Uso:

- Uso quotidiano
- Sport dinamici
- Corsa in natura
- Corsa
- Marcia
- Ciclismo
- Ambienti interni

Caratteristiche:

- Antibatterico
- Antimicotico
- Antiodore
- Delicato sulla pelle
- Attenua gli arrossamenti, le screpolature, la formazione di vesciche, la desquamazione e il prurito

47% Polypropylen
27% Polyamid
23% Cupron (Kupfer-Polyamid)
3% Elasthan



Rohner	Europe	US Men's	US Women
S	36 - 38	3 - 5½	4½ - 6½
M	39 - 41	6 - 8	7½ - 9½
L	42 - 44	8½ - 10	10 - 11½
XL	44 - 46	10 - 12	11+
XXL	47 - 48	12½ - 13	

allround sneaker l/r

62.243/0 *Solange Vorrat*



Cushion/Volume:



Season:



low cut

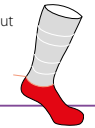

Besonderheiten:

- Elastzone im Ristbereich
- Gekettelt



Specificities:

- Elastic zone in instep area
- Seamless



Particularités:

- Zone du cou-de-pied élastique
- Remmaillée



Particolarità:

- Zona elastica nell'area del collo del piede
- Punta rimagliata



008

Hauptvorteil:

- Fusskomfort

Entwickelt für:

- Sport
- Alltag

Sport / Verwendung:

- Alltagsgebrauch
- Aktive Sportarten
- Hallensport

Eigenschaften:

- Feiner Plüsch in Spitze, Ferse und Ballenbereich
- Anatomische Passform

Main Benefit:

- Foot Wellness

Designed For:

- For sports
- Daily use

Sports / Use:

- Daily use
- Active Sports
- Indoor

Features:

- Fein plush in toe, heel and ball area
- Anatomical fit

Principal avantage:

- Confort fraîcheur et bien-être du pied

Conçue pour:

- Pour sports
- Utilisation quotidienne

Sports / Utilisations:

- Utilisation quotidienne
- Sports actifs
- Sports en salle

Caractéristiques:

- Peluche au niveau de la pointe, des coussinets et de la cheville
- Forme anatomique

Vantaggio principale:

- Freschezza, comfort e benessere del piede

Progettato per:

- Per sport
- Uso quotidiano

Sport / Uso:

- Uso quotidiano
- Sport dinamici
- Ambienti interni

Caratteristiche:

- Imbottitura leggera nella punta, nel tallone e area metatarso
- Calzata anatomica



009

36% Polypropylen (Polycolon®)
29% Polyamid
27% Polyester (Dri-Release®)
6% Baumwolle / cotton
2% Elasthan (Lycra®)



Rohner	Europe	US Men's	US Women
S	36 - 38	3 - 5 1/2	4 1/2 - 6 1/2
M	39 - 41	6 - 8	7 1/2 - 9 1/2
L	42 - 44	8 1/2 - 10	10 - 11 1/2
XL	44 - 46	10 - 12	11+

allround quarter l/r

62.243/2 *Solange Vorrat*



Cushion/Volume:



Season:



1/4 crew



Besonderheiten:

- Elastzone im Ristbereich
- Gekettelt



Specificities:

- Elastic zone in instep area
- Seamless



Particularités:

- Zone du cou-de-pied élastique
- Remmaillée



Particolarità:

- Zona elastica nell'area del collo del piede
- Punta rimagliata



009

Hauptvorteil:

- Fusskomfort

Entwickelt für:

- Sport
- Alltag

Sport / Verwendung:

- Alltagsgebrauch
- Aktive Sportarten
- Hallensport

Eigenschaften:

- Feiner Plüsch in Spitze, Ferse und Ballenbereich
- Anatomische Passform

Main Benefit:

- Foot Wellness

Designed For:

- For sports
- Daily use

Sports / Use:

- Daily use
- Active Sports
- Indoor

Features:

- Fein plush in toe, heel and ball area
- Anatomical fit

Principal avantage:

- Confort fraîcheur et bien-être du pied

Conçue pour:

- Pour sports
- Utilisation quotidienne

Sports / Utilisations:

- Utilisation quotidienne
- Sports actifs
- Sports en salle

Caractéristiques:

- Peluche au niveau de la pointe, des coussinets et de la cheville
- Forme anatomique

Vantaggio principale:

- Freschezza, comfort e benessere del piede

Progettato per:

- Per sport
- Uso quotidiano

Sport / Uso:

- Uso quotidiano
- Sport dinamici
- Ambienti interni

Caratteristiche:

- Imbottitura leggera nella punta, nel tallone e area metatarso
- Calzata anatomica



008

32% Polyester (Dri-Release®)
 31% Polypropylen (Polycolon®)
 28% Polyamid
 7% Baumwolle / cotton
 2% Elasthan (Lycra®)

drirelease®



Polycolon®
 for active wear

Rohner	Europe	US Men's	US Women
S	36 - 38	3 - 5 1/2	4 1/2 - 6 1/2
M	39 - 41	6 - 8	7 1/2 - 9 1/2
L	42 - 44	8 1/2 - 10	10 - 11 1/2
XL	44 - 46	10 - 12	11+

allround l/r

62.243/1 *Solange Vorrat*



Cushion/Volume:



Season:



crew cut



Besonderheiten:

- Elastzone im Ristbereich
- Gekettelt



Specificities:

- Elastic zone in instep area
- Seamless



Particularités:

- Zone du cou-de-pied élastique
- Remmaillée



Particolarità:

- Zona elastica nell'area del collo del piede
- Punta rimagliata

Hauptvorteil:

- Fusskomfort

Entwickelt für:

- Sport
- Alltag

Sport / Verwendung:

- Alltagsgebrauch
- Aktive Sportarten
- Hallensport

Eigenschaften:

- Feiner Plüsch in Spitze, Ferse und Ballenbereich
- Anatomische Passform

Main Benefit:

- Foot Wellness

Designed For:

- For sports
- Daily use

Sports / Use:

- Daily use
- Active Sports
- Indoor

Features:

- Fein plush in toe, heel and ball area
- Anatomical fit

Principal avantage:

- Confort fraîcheur et bien-être du pied

Conçue pour:

- Pour sports
- Utilisation quotidienne

Sports / Utilisations:

- Utilisation quotidienne
- Sports actifs
- Sports en salle

Caractéristiques:

- Peluche au niveau de la pointe, des coussinets et de la cheville
- Forme anatomique

Vantaggio principale:

- Freschezza, comfort e benessere del piede

Progettato per:

- Per sport
- Uso quotidiano

Sport / Uso:

- Uso quotidiano
- Sport dinamici
- Ambienti interni

Caratteristiche:

- Imbottitura leggera nella punta, nel tallone e area metatarso
- Calzata anatomica



009

35% Polyester (Dri-Release®)
28% Polyamid
27% Polypropylen (Polycolon®)
8% Baumwolle / cotton
2% Elasthan (Lycra®)

drirelease®



Polycolon®
for active wear

Rohner	Europe	US Men's	US Women
S	36 - 38	3 - 5½	4½ - 6½
M	39 - 41	6 - 8	7½ - 9½
L	42 - 44	8½ - 10	10 - 11½
XL	44 - 46	10 - 12	11+

grand slam l/r

62.014/1



Cushion/Volume:



Season:



3/4 crew



174

Besonderheiten:

- Pique-Struktur
- Verstärkte Hochferse und Spitze mit Profilen®
- Rohner Air Channel-System im Fussbereich
- Plüsch im Fussbereich
- Gekettelt

Hauptvorteil:

- Maximaler Fusskomfort

Entwickelt für:

- Höchste Leistungen

Sport / Verwendung:

- Tennis
- Hallensport

Eigenschaften:

- Antibakteriell
- Geruchshemmend
- Antistatisch
- Plüsch im Fussbereich
- R.A.C.S.
- Anatomische Passform
- Pique-Struktur

Specificities:

- Piqué structure
- Reinforced high heel and toe with Profilen®
- Rohner Air Channel System in foot area
- Terry construction in foot area
- Seamless

Main Benefit:

- Maximum Foot Comfort

Designed For:

- Ultimate Performance

Sports / Use:

- Tennis
- Indoor

Features:

- Antibacterial
- Anti-odor
- Antistatic
- Terry construction in foot area
- R.A.C.S.
- Anatomical fit
- Pique structure

Particularités:

- Structure de piqué
- Talons prolongés et pointes renforcés avec Profilen®
- Circulation de l'air optimisée par le Rohner Air Channel System
- Peluche dans la zone du pied
- Remmaillée

Principal avantage:

- Confort du pied maximale

Conçue pour:

- Performances ultimes

Sports / Utilisations:

- Tennis
- Sports en salle

Caractéristiques:

- Antibactérienne
- Anti-odeur
- Antistatique
- Peluche dans la zone du pied
- R.A.C.S.
- Forme anatomique
- Structure de piqué

Particolarità:

- Struttura piqué
- Tallone rialzato rinforzato e punta rinforzata con Profilen®
- Sistema Rohner Air Channel System nell'area del piede
- Interno in tessuto felpato nella zona del piede
- Punta rimagliata

Vantaggio principale:

- Massimo comfort per il piede

Progettato per:

- Prestazioni superiori

Sport / Uso:

- Tennis
- Ambienti interni

Caratteristiche:

- Antibatterico
- Antiodore
- Antistatico
- Interno in tessuto felpato nella zona del piede
- Sistema R.A.C.S.
- Calzata anatomica
- Struttura piqué

48% Tencel
20% Polyamid (MerylSkinlife®)
14% Polyamid (Tactel®)
9% Polyamid
8% PTFE (Profilen®)
1% Elasthan (Lycra®)



Rohner	Europe	US Men's
S	36 - 38	3 - 5 1/2
M	39 - 41	6 - 8
L	42 - 44	8 1/2 - 10
XL	44 - 46	10 - 12

working light

40.020/2

working

Cushion/Volume:



Season:



crew cut



009

- Besonderheiten:**
- Plüsch im Fussbereich
 - Gekettelt

- Specificities:**
- Terry construction in foot area
 - Seamless

- Particularités:**
- Peluche dans la zone du pied
 - Remmaillée

- Particolarità:**
- Interno in tessuto felpato nella zona del piede
 - Punta rimagliata

- Hauptvorteil:**
- Besondere Belastbarkeit
 - Gute Isolation
 - Komfort

- Main Benefit:**
- Extra Durable
 - Good isolation
 - Comfort

- Principal avantage:**
- Durabilité accrue
 - Bon isolation
 - Confort

- Vantaggio principale:**
- Calore
 - Durabilità superiore
 - Comfort

- Entwickelt für:**
- Arbeitsschuhe

- Designed For:**
- Work boots

- Conçue pour:**
- Brodequins

- Progettato per:**
- Scarponi da lavoro

- Sport / Verwendung:**
- Einsatzteam
 - Arbeiten

- Sports / Use:**
- Task force
 - Working

- Sports / Utilisations:**
- Force opérationnelle
 - Travail

- Sport / Uso:**
- Task force
 - Lavoro

- Eigenschaften:**
- Widerstandsfähig
 - Weicher Abschlussrand
 - Abriebfestigkeit

- Features:**
- Wear resistance
 - Soft border
 - Abrasion resistance

- Caractéristiques:**
- Résistance
 - Bords non comprimants
 - Résistance à l'abrasion

- Caratteristiche:**
- Resistenza all'usura
 - Bordo in tessuto morbido
 - Resistenza all'abrasione

80% Wolle (Merino) / Wool (Merino)
20% Polyamid



Rohner	Europe	US Men's	US Women
S	36 - 38	3 - 5 1/2	4 1/2 - 6 1/2
M	39 - 41	6 - 8	7 1/2 - 9 1/2
L	42 - 44	8 1/2 - 10	10 - 11 1/2
XL	44 - 46	10 - 12	11+
XXL	47 - 49	13 - 15	

army / working

40.030/2

working

Cushion/Volume:



Season:



crew cut



059



009*

Besonderheiten:

- Mit zusätzlicher Plüschpolsterung hinten im Rohr
- Plüsch im Fussbereich
- Gekettelt

Hauptvorteil:

- Besondere Belastbarkeit
- Gute Isolation
- Komfort

Entwickelt für:

- Arbeitsschuhe

Sport / Verwendung:

- Einsatzteam
- Arbeiten

Eigenschaften:

- Widerstandsfähig
- Weicher Abschlussrand
- Abriebfestigkeit

Specificities:

- With additional padding in the rear of the tube
- Terry construction in foot area
- Seamless

Main Benefit:

- Extra Durable
- Good isolation
- Comfort

Designed For:

- Work boots

Sports / Use:

- Task force
- Working

Features:

- Wear resistance
- Soft border
- Abrasion resistance

Particularités:

- Rembourrage en peluche supplémentaire dans la partie arrière du montant
- Peluche dans la zone du pied
- Remmaillée

Principal avantage:

- Durabilité accrue
- Bon isolation
- Confort

Conçue pour:

- Brodequins

Sports / Utilisations:

- Force opérationnelle
- Travail

Caractéristiques:

- Résistance
- Bords non comprimants
- Résistance à l'abrasion

Particolarità:

- Con rivestimento aggiuntivo nel retro del tubo
- Interno in tessuto felpato nella zona del piede
- Punta rimagliata

Vantaggio principale:

- Calore
- Durabilità superiore
- Comfort

Progettato per:

- Scarponi da lavoro

Sport / Uso:

- Task force
- Lavoro

Caratteristiche:

- Resistenza all'usura
- Bordo in tessuto morbido
- Resistenza all'abrasione

56% Schurwolle / new wool
44% Polyamid



Rohner	Europe	US Men's	US Women
S	36 - 38	3 - 5 1/2	4 1/2 - 6 1/2
M	39 - 41	6 - 8	7 1/2 - 9 1/2
L	42 - 44	8 1/2 - 10	10 - 11 1/2
XL	44 - 46	10 - 12	11+
XXL*	47 - 49	13 - 15	

XXL* - nur / only / seulement / solo col. 009

Kids

so macht Sport von Anfang an Spass



SAC globi trekking

24.956/6 *Limited Edition*



561



Besonderheiten:

- Plüsch im Fussbereich
- Gekettelt



Specificities:

- Terry construction in foot area
- Seamless



Particularités:

- Peluche dans la zone du pied
- Remmaillée



Particolarità:

- Interno in tessuto felpato nella zona del piede
- Punta rimagliata

Cushion/Volume:



Season:



crew cut



Hauptvorteil:

- Feuchtigkeitsregulierung

Main Benefit:

- Moisture management

Principal avantage:

- Gestion de l'humidité

Vantaggio principale:

- Gestione dell'umidità

Entwickelt für:

- Freizeit

Designed For:

- Leisure

Conçue pour:

- Loisirs

Progettato per:

- Tempo libero

Sport / Verwendung:

- Freizeit
- Wandern

Sports / Use:

- Leisure
- Trekking

Sports / Utilisations:

- Loisirs
- Trekking

Sport / Uso:

- Tempo libero
- Trekking

Eigenschaften:

- Plüsch im Fussbereich

Features:

- Terry construction in foot area

Caractéristiques:

- Peluche dans la zone du pied

Caratteristiche:

- Interno in tessuto felpato nella zona del piede

globi trekking

24.956/1



228

40% Polyamid
21% Wolle / wool
20% Polyacryl
18% Polyester
1% Elasthan (Lycra®)



Rohrer	Europe	US Kids
S	23 - 26	6 - 9
M	27 - 30	9 - 12
L	31 - 34	13 - 2
XL	35 - 38	3 - 6

globi trekking

24.955/1 *Solange Vorrat*

Cushion/Volume:



Season:



crew cut



304



493

Besonderheiten:

- Plüsch im Fussbereich
- Gekettelt

Specificities:

- Terry construction in foot area
- Seamless

Particularités:

- Peluche dans la zone du pied
- Remmaillée

Particolarità:

- Interno in tessuto felpato nella zona del piede
- Punta rimagliata

Hauptvorteil:

- Feuchtigkeitsregulierung

Main Benefit:

- Moisture management

Principal avantage:

- Gestion de l'humidité

Vantaggio principale:

- Gestione dell'umidità

Entwickelt für:

- Freizeit

Designed For:

- Leisure

Conçue pour:

- Loisirs

Progettato per:

- Tempo libero

Sport / Verwendung:

- Freizeit
- Wandern

Sports / Use:

- Leisure
- Trekking

Sports / Utilisations:

- Loisirs
- Trekking

Sport / Uso:

- Tempo libero
- Trekking

Eigenschaften:

- Plüsch im Fussbereich

Features:

- Terry construction in foot area

Caractéristiques:

- Peluche dans la zone du pied

Caratteristiche:

- Interno in tessuto felpato nella zona del piede

26% Polyester
25% Polyamid
24% Schurwolle / new wool
24% Polyacryl
1% Elasthan (Lycra®)



Rohner	Europe	US Kids
S	23 - 26	6 - 9
M	27 - 30	9 - 12
L	31 - 34	13 - 2
XL	35 - 38	3 - 6

hiking kids

24.003/1

Cushion/Volume:



Season:



crew cut



Besonderheiten:

- Gepolsterte Hochferse
- Spezielle Polsterzonen im Rist- und Schienbeinbereich
- Elastzone im Fussbereich
- Gekettelt



Specificities:

- Padded high heel
- Special padding zones in the instep and shinbone zone
- Elastic zone in foot area
- Seamless



Particularités:

- Haut du talon rembourré
- Rembourrage cou de pied et tibia
- Renforcement élastique dans la zone du pied
- Remmaillée



Particolarità:

- Parte alta del tallone imbottita
- Speciali imbottiture nella zona del collo del piede e dello stinco
- Zona elastica nell'area del piede
- Punta rimagliata

Hauptvorteil:

- Thermoregulierung

Entwickelt für:

- Alle Bedingungen

Sport / Verwendung:

- Rucksacktouren
- Wandern
- Bergtouren

Eigenschaften:

- Ristpolsterung
- Schienbeinschutz
- Plüschpolsterung im Fussbereich
- Thermoregulierung

Main Benefit:

- Thermoregulation

Designed For:

- All conditions

Sports / Use:

- Backpacking
- Trekking
- Hiking

Features:

- Instep cushioning
- Shinbone protection
- Terry construction in foot area
- Thermoregulation

Principal avantage:

- Régulation thermique

Conçue pour:

- Toutes conditions météorologiques

Sports / Utilisations:

- Grande randonnée
- Trekking
- Randonnée pédestre

Caractéristiques:

- Protection du cou-de-pied
- Protection du tibia
- Construction en peluche dans la zone du pied
- Régulation thermique

Vantaggio principale:

- Termoregolante

Progettato per:

- Adatto in tutte le condizioni climatiche

Sport / Uso:

- Turismo con zaino
- Trekking
- Escursionismo

Caratteristiche:

- Protezione del collo del piede
- Protezione dello stinco
- Struttura in spugna nell'area del piede
- Termoregolante

52% Polyester (Thermocool)
26% Polyamid
22% Walle (Merino) / Wool (Merino)



Rohner	Europe	US Kids
S	23 - 26	6 - 9
M	27 - 30	9 - 12
L	31 - 34	13 - 2
XL	35 - 38	3 - 6

fibre high tech junior

24.200/1



Cushion/Volume:



Season:



crew cut



115



401**

114**

Besonderheiten:

- Weicher Abschlussrand
- Elastzone für besseren Halt
- »IN&OUT« Technologie
- Plüsch im Fussbereich
- Pique-Technik für bessere Passform im Fussrückenbereich
- Gekettelt

Hauptvorteil:

- Feuchtigkeitsregulierung

Entwickelt für:

- Schuhe mit Membranfutter

Sport / Verwendung:

- Wandern
- Bergtouren

Eigenschaften:

- Plüsch im Fussbereich
- Natürliche Feuchtigkeitsregulierung
- Für Schuhe mit Membranfutter
- Weicher Abschlussrand
- Pique-Struktur

49% Polyester (Coolmax®)
30% Wolle (Merino) / Wool (Merino)
12% Polyacryl
7% Polypropylen
1% Polyamid
1% Elasthan (Lycra®)

Specificities:

- Soft border
- Elastic zone for improved support
- «IN&OUT» Technology
- Terry construction in foot area
- Pique knit for improved fit around the back of the foot
- Seamless

Main Benefit:

- Moisture management

Designed For:

- Membrane lined boots

Sports / Use:

- Trekking
- Hiking

Features:

- Terry construction in foot area
- Natural moisture management
- For membran liner footwear
- Soft border
- Pique structure

Particularités:

- Bords non comprimants
- Zone élastique pour un meilleur maintien
- Technologie de «IN&OUT»
- Peluche dans la zone du pied
- Technique piqué pour un meilleur ajustement au niveau du dos du pied
- Remmaillée

Principal avantage:

- Gestion de l'humidité

Conçue pour:

- Chaussures doublées en membrane

Sports / Utilisations:

- Trekking
- Randonnée pédestre

Caractéristiques:

- Peluche dans la zone du pied
- Gestion naturelle de l'humidité
- Pour chaussures doublées en membrane
- Bords non comprimants
- Structure de piqué

Particolarità:

- Bordo in tessuto morbido
- Zona elastica per un supporto migliorato
- Tecnologia «IN&OUT»
- Interno in tessuto felpato nella zona del piede
- Piqué per una calzata migliorata tattorno al collo del piede
- Punta rimagliata

Vantaggio principale:

- Gestione dell'umidità

Progettato per:

- Scarponi con fodera interna

Sport / Uso:

- Trekking
- Escursionismo

Caratteristiche:

- Interno in tessuto felpato nella zona del piede
- Gestione naturale dell'umidità
- Per calzature con fodera interna
- Bordo in tessuto morbido
- Struttura piqué



schoeller
the spinning group



Rohner	Europe	US Kids
S	23 - 26	6 - 9
M	27 - 30	9 - 12
L	31 - 34	13 - 2
XL	35 - 38	3 - 6

** – solange Vorrat

power tech junior

25.220/3

advanced technology

Cushion/Volume:



Season:



over the calf



114



329

Besonderheiten:

- Luftkanäle
- «In&Out»-Technik
- Elastzone für besseren Halt
- Gekettelt

Hauptvorteil:

- Feuchtigkeitsregulierung und Polsterung

Entwickelt für:

- Herausragenden Komfort

Sport / Verwendung:

- Allmountain

Eigenschaften:

- Antibakteriell
- Geruchshemmend
- Antistatisch
- Knöchelschutz
- Vollplüschsocke
- Pique-Struktur

Specificities:

- Air channels
- «In&Out» technology
- Elastic zone for improved support
- Seamless

Main Benefit:

- Moisture management and cushioning

Designed For:

- Superior comfort

Sports / Use:

- Allmountain

Features:

- Antibacterial
- Anti-odor
- Antistatic
- Ankle protection
- Full terry construction
- Pique structure

Particularités:

- Canaux d'aération
- Technique «In&Out»
- Zone élastique pour un meilleur maintien
- Remmaillée

Principal avantage:

- Gestion de l'humidité et rembourrage

Conçue pour:

- Confort supérieur

Sports / Utilisations:

- Tous les sports et activités de montagne

Caractéristiques:

- Antibactérienne
- Anti-odeur
- Antistatique
- Protection de la cheville
- Construction pleine peluche
- Structure de piqué

Particolarità:

- Canali per il passaggio dell'aria
- Tecnologia «In&Out»
- Zona elastica per un supporto migliorato
- Punta rimagliata

Vantaggio principale:

- Gestione dell'umidità e ammortizzamento

Progettato per:

- Comfort ottimale

Sport / Uso:

- Tutte le pratiche alpinistiche

Caratteristiche:

- Antibatterico
- Antiodore
- Antistatico
- Protezione della caviglia
- Struttura interamente in spugna
- Struttura piqué

39% Schurwolle / new wool
25% Polyacryl
21% Polyamid
7% Polyamid (MerylSkinlife®)
7% Polypropylen
1% Elasthan (Lycra®)



schoeller
the spinning group

Rohner	Europe	US Kids
M	27 - 30	9 - 12
L	31 - 34	13 - 2
XL	35 - 38	3 - 6

SAC globi ski

25.066/6



114



Besonderheiten:

- Vollplüschsocke
- Elastzone für besseren Halt



Specificities:

- Full terry construction
- Elastic zone for improved support



Particularités:

- Construction pleine peluche
- Zone élastique pour un meilleur maintien



Particolarità:

- Struttura interamente in spugna
- Zona elastica per un supporto migliorato

Cushion/Volume:



Season:



over the calf



Hauptvorteil:

- Optimaler Komfort

Main Benefit:

- Optimal comfort

Principal avantage:

- Confort optimal

Vantaggio principale:

- Comfort ottimale

Entwickelt für:

- Allround

Designed For:

- Allround

Conçue pour:

- Toutes les utilisations possibles

Progettato per:

- Tutti gli impieghi

Sport / Verwendung:

- Ski / Snowboard

Sports / Use:

- Ski / Snowboard

Sports / Utilisations:

- Ski / Snowboard

Sport / Uso:

- Sci / Snowboard

Eigenschaften:

- Vollplüschsocke

Features:

- Full terry construction

Caractéristiques:

- Construction pleine peluche

Caratteristiche:

- Struttura interamente in spugna

globi ski

25.066/3



514

48% Polyacryl
40% Schurwolle / new wool
11% Polyamid
1% Elasthan (Lycra®)



Rohner	Europe	US Kids
S	23 - 26	6 - 9
M	27 - 30	9 - 12
L	31 - 34	13 - 2
XL	35 - 38	3 - 6

globi ski

25.064/3 *Solange Vorrat*

Cushion/Volume:



Season:



over the calf



186



114



Besonderheiten:

- Vollplüschsocke
- Elastzone für besseren Halt



Specificities:

- Full terry construction
- Elastic zone for improved support



Particularités:

- Construction pleine peluche
- Zone élastique pour un meilleur maintien



Particolarità:

- Struttura interamente in spugna
- Zona elastica per un supporto migliorato

Hauptvorteil:

- Optimaler Komfort

Entwickelt für:

- Allround

Sport / Verwendung:

- Ski / Snowboard

Eigenschaften:

- Vollplüschsocke

Main Benefit:

- Optimal comfort

Designed For:

- Allround

Sports / Use:

- Ski / Snowboard

Features:

- Full terry construction

Principal avantage:

- Confort optimal

Conçue pour:

- Toutes les utilisations possibles

Sports / Utilisations:

- Ski / Snowboard

Caractéristiques:

- Construction pleine peluche

Vantaggio principale:

- Comfort ottimale

Progettato per:

- Tutti gli impieghi

Sport / Uso:

- Sci / Snowboard

Caratteristiche:

- Struttura interamente in spugna

48% Polyacryl
40% Schurwolle / new wool
11% Polyamid
1% Elasthan (Lyca®)



Rohner	Europe	US Kids
S	23 - 26	6 - 9
M	27 - 30	9 - 12
L	31 - 34	13 - 2
XL	35 - 38	3 - 6

native junior

25.253/3

Cushion/Volume:



Season:



over the calf



009



Besonderheiten:

- Vollplüschsocke
- Elastzone für besseren Halt



Specificities:

- Full terry construction
- Elastic zone for improved support



Particularités:

- Construction pleine peluche
- Zone élastique pour un meilleur maintien



Particolarità:

- Struttura interamente in spugna
- Zona elastica per un supporto migliorato

Hauptvorteil:

- Optimaler Komfort

Entwickelt für:

- Allround

Sport / Verwendung:

- Ski / Snowboard

Eigenschaften:

- Vollplüschsocke
- Flachnaht

Main Benefit:

- Optimal comfort

Designed For:

- Allround

Sports / Use:

- Ski / Snowboard

Features:

- Full terry construction
- Flat seam

Principal avantage:

- Confort optimal

Conçue pour:

- Toutes les utilisations possibles

Sports / Utilisations:

- Ski / Snowboard

Caractéristiques:

- Construction pleine peluche
- Couture plate

Vantaggio principale:

- Comfort ottimale

Progettato per:

- Tutti gli impieghi

Sport / Uso:

- Sci / Snowboard

Caratteristiche:

- Struttura interamente in spugna
- Cucitura piatta



010

48% Polyacryl
40% Schurwolle / new wool
11% Polyamid
1% Elasthan (Lycra®)



schoeller
the spinning group

Rohner	Europe	US Kids
S	23 - 26	6 - 9
M	27 - 30	9 - 12
L	31 - 34	13 - 2
XL	35 - 38	3 - 6

carolina

25.045/3



661



304

157***

Besonderheiten:

- Vollplüschsocke
- Elastzone für besseren Halt

Hauptvorteil:

- Optimaler Komfort

Entwickelt für:

- Allround

Sport / Verwendung:

- Ski / Snowboard

Eigenschaften:

- Vollplüschsocke
- Flachnaht

Specificities:

- Full terry construction
- Elastic zone for improved support

Main Benefit:

- Optimal comfort

Designed For:

- Allround

Sports / Use:

- Ski / Snowboard

Features:

- Full terry construction
- Flat seam

Particularités:

- Construction pleine peluche
- Zone élastique pour un meilleur maintien

Principal avantage:

- Confort optimal

Conçue pour:

- Toutes les utilisations possibles

Sports / Utilisations:

- Ski / Snowboard

Caractéristiques:

- Construction pleine peluche
- Couture plate

Particolarità:

- Struttura interamente in spugna
- Zona elastica per un supporto migliorato

Vantaggio principale:

- Comfort ottimale

Progettato per:

- Tutti gli impieghi

Sport / Uso:

- Sci / Snowboard

Caratteristiche:

- Struttura interamente in spugna
- Cucitura piatta

Cushion/Volume:



Season:



over the calf



48% Polyacryl
40% Schurwolle / new wool
11% Polyamid
1% Elasthan (Lycra®)



schoeller
the spinning group

Rohner	Europe	US Kids
S	23 - 26	6 - 9
M	27 - 30	9 - 12
L	31 - 34	13 - 2
XL	35 - 38	3 - 6

*** - Limited Edition

pinguin

25.009/3

Cushion/Volume:



Season:



over the calf



010



Besonderheiten:

- Vollplüschsocke
- Elastzone für besseren Halt



Specificities:

- Full terry construction
- Elastic zone for improved support



Particularités:

- Construction pleine peluche
- Zone élastique pour un meilleur maintien



Particolarità:

- Struttura interamente in spugna
- Zona elastica per un supporto migliorato

Hauptvorteil:

- Optimaler Komfort

Entwickelt für:

- Allround

Sport / Verwendung:

- Ski / Snowboard

Eigenschaften:

- Vollplüschsocke
- Flachnaht

Main Benefit:

- Optimal comfort

Designed For:

- Allround

Sports / Use:

- Ski / Snowboard

Features:

- Full terry construction
- Flat seam

Principal avantage:

- Confort optimal

Conçue pour:

- Toutes les utilisations possibles

Sports / Utilisations:

- Ski / Snowboard

Caractéristiques:

- Construction pleine peluche
- Couture plate

Vantaggio principale:

- Comfort ottimale

Progettato per:

- Tutti gli impieghi

Sport / Uso:

- Sci / Snowboard

Caratteristiche:

- Struttura interamente in spugna
- Cucitura piatta



114

186

607

48% Polyacryl
40% Schurwolle / new wool
11% Polyamid
1% Elasthan (Lycra®)



schoeller
the spinning group

Rohner	Europe	US Kids
S	23 - 26	6 - 9
M	27 - 30	9 - 12
L	31 - 34	13 - 2
XL	35 - 38	3 - 6

triangle junior

25.252/3 *Solange Vorrat*

Cushion/Volume:



Season:



over the calf



400



090



009

- Besonderheiten:**
- Vollplüschsocke
 - Elastzone im Ristbereich

- Specificities:**
- Full terry construction
 - Elastzone in instep area

- Particularités:**
- Construction pleine peluche
 - Zone du cou-de-pied élastique

- Particolarità:**
- Struttura interamente in spugna
 - Zona in elastomero nell'area del collo del piede

- Hauptvorteil:**
- Optimaler Komfort

- Main Benefit:**
- Optimal comfort

- Principal avantage:**
- Confort optimal

- Vantaggio principale:**
- Comfort ottimale

- Entwickelt für:**
- Allround

- Designed For:**
- Allround

- Conçue pour:**
- Toutes les utilisations possibles

- Progettato per:**
- Tutti gli impieghi

- Sport / Verwendung:**
- Ski / Snowboard

- Sports / Use:**
- Ski / Snowboard

- Sports / Utilisations:**
- Ski / Snowboard

- Sport / Uso:**
- Sci / Snowboard

- Eigenschaften:**
- Vollplüschsocke
 - Flachnaht

- Features:**
- Full terry construction
 - Flat seam

- Caractéristiques:**
- Construction pleine peluche
 - Couture plate

- Caratteristiche:**
- Struttura interamente in spugna
 - Cucitura piatta

48% Polyacryl
40% Schurwolle / new wool
11% Polyamid
1% Elasthan (Lycra®)



schoeller
the spinning group

Rohner	Europe	US Kids
S	23 - 26	6 - 9
M	27 - 30	9 - 12
L	31 - 34	13 - 2
XL	35 - 38	3 - 6

Business Men

Schritt für Schritt durch den Alltag



sneaker low

10.236/0

Season:



low cut



Besonderheiten:

- Anti-Slip System
- Flachnaht



Specificities:

- Anti-slip system
- Flat seam



Particularités:

- Anti-glisement système
- Couture plate



Particolarità:

- Antiscivolo sistema
- Cucitura piatta

Hauptvorteil:

- Feuchtigkeitsregulierung

Eigenschaften:

- Geruchshemmend
- Fusskomfort
- Glatt

Main Benefit:

- Moisture management

Features:

- Anti-odor
- Foot wellness
- Plain

Principal avantage:

- Gestion de l'humidité

Caractéristiques:

- Anti-odeur
- Bien-être du pied
- Couture plate

Vantaggio principale:

- Gestione dell'umidità

Caratteristiche:

- Antiodore
- Benessere del piede
- Cucitura piatta



009*



008*

010

661

80% Coolmax®
18% Polyamid
2% Elasthan



Rohrer	Europe	US Men's	US Women
S	36 - 38	3 - 5 1/2	4 1/2 - 6 1/2
M	39 - 41	6 - 8	7 1/2 - 9 1/2
L	42 - 44	8 1/2 - 10	10 - 11 1/2
XL	44 - 46	11 - 12	11+
XXL*	47 - 49	13 - 15	-

* XXL - nur / only / seulement / solo col. 008 und 009

sneaker wellness

10.235/0

wellness

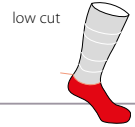
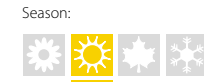

paarweise nummeriert • numbered in pairs • numérotés par paire • numerate in coppia



009



Besonderheiten:
■ Gekettelt



Specificities:
■ Seamless



Particularités:
■ Remmaillée



Particolarità:
■ Punta rimagliata

Eigenschaften:

- Antibakteriell
- Geruchshemmend
- Antistatisch
- Fusskomfort
- Glatt
- Nummeriert

Features:

- Antibacterial
- Anti-odor
- Antistatic
- Foot wellness
- Plain
- Numbered

Caractéristiques:

- Antibactérienne
- Anti-odeur
- Antistatique
- Bien-être du pied
- Lisse
- Numérotée

Caratteristiche:

- Antibatterico
- Antiodore
- Antistatico
- Benessere del piede
- Liscio
- Numerato



010**

002**

52% Baumwolle / cotton
24% Polyamid
15% SeaCell®
8% Smartcel® Sensitive
1% Elasthan (Lycra®)



Rohner	Europe	US Men's
S	36 - 38	3 - 5 1/2
M	39 - 41	6 - 8
L	42 - 44	8 1/2 - 10
XL	44 - 46	10 - 12

** – solange Vorrat

supeR organic cotton

10.104/1

bio cotton

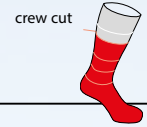
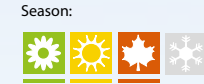

Nummeriert in coppia • paarweise nummeriert • numbered in pair • numératees par paire • numerotées par paire



- Besonderheiten:**
- Rutschfestes Rohr
 - Verstärkung der Hochferse und des Ballenbereiches
 - Gekettelt



- Specificities:**
- Antislip tube
 - High heel and ball of the foot reinforcement
 - Seamless



- Particularités:**
- Tricot jambe anti-glissement
 - Haut du talon et région du métatarse renforcés
 - Remmaillée



- Particolarità:**
- Tubo antiscivolo
 - Parte alta del tallone ed estremità del metatarso rinforzati
 - Punta rimagliata

Eigenschaften:

- Organische Baumwolle
- Rutschfestes Rohr
- Hochferseverstärkung
- Ballenverstärkung
- Nummeriert
- Gerippt

Features:

- Organic cotton
- Antislip tube
- High heel reinforcement
- Ball of the foot reinforcement
- Numbered
- Ribbed

Caractéristiques:

- Coton bio
- Tricot jambe anti-glissement
- Haut du talon renforcé
- Région du métatarse renforcé
- Numérotée
- À côte

Caratteristiche:

- Cottone organico
- Tubo antiscivolo
- Caviglia rinforzata
- Arco plantare rinforzato
- Numerato
- A coste

009

73% Baumwolle / cotton
Swiss Cotton® / Organic
22% Polyamid
5% Elasthan (Lycra®)



Rohner	Europe	US Men's
S	39 - 40	6 - 7½
M	41 - 42	8 - 8½
L	43 - 44	9 - 10
XL	45 - 46	10½ - 12

superR BW

10.024/1

cotton



Season:



crew cut



numeriert in pairs • numbered in pairs • numerate in coppia • paarweise nummeriert • numerate in coppia • paarweise nummeriert



009*

- Besonderheiten:**
- Verstärkte Hochferse
 - Ballenverstärkung
 - Gekettelt

- Eigenschaften:**
- Rutschfestes Rohr
 - Hochfersenverstärkung
 - Ballenverstärkung
 - Nummeriert
 - Gerippt

- Specificities:**
- Reinforced high-heel
 - Ball of the foot reinforcement
 - Seamless

- Features:**
- Antislip tube
 - High heel reinforcement
 - Ball of the foot reinforcement
 - Numbered
 - Ribbed

- Particularités:**
- Haut du talon renforcé
 - Coussinets plantaires renforcée
 - Remmaillée

- Caractéristiques:**
- Tricot jambe anti-glisserment
 - Haut du talon renforcé
 - Région du métatarse renforcé
 - Numérotée
 - À côte

- Particolarità:**
- Tallone rinforzato di altezza maggiorata
 - Estremità del metatarso rinforzate
 - Punta rimagliata

- Caratteristiche:**
- Tubo antiscivolo
 - Caviglia rinforzata
 - Arco plantare rinforzato
 - Numerato
 - A coste



366 008* 290 046 538 010* 454*** 455*** 456*** 289***

73% Baumwolle / cotton
22% Polyamid
5% Elasthan (Lykra®)



Röhner	Europe	US Men's
S	39 - 40	6 - 7 1/2
M	41 - 42	8 - 8 1/2
L	43 - 44	9 - 10
XL	45 - 46	10 1/2 - 12
XXL*	47 - 48	12 1/2 - 13

XXL* – nur / only / seulement / solo col. 008/009/010
*** – Limited Edition

superR BW long

10.024/3

cotton



Season:



over the calf



- Besonderheiten:**
- Verstärkte Hochferse
 - Ballenverstärkung
 - Gekettelt

- Specificities:**
- Reinforced high-heel
 - Ball of the foot reinforcement
 - Seamless

- Particularités:**
- Haut du talon renforcé
 - Coussinets plantaires renforcée
 - Remmaillée

- Particolarità:**
- Tallone rinforzato di altezza maggiorata
 - Estremità del metatarso rinforzate
 - Punta rimagliata

- Eigenschaften:**
- Rutschfestes Rohr
 - Hochfersenverstärkung
 - Ballenverstärkung
 - Nummeriert
 - Gerippt

- Features:**
- Antislip tube
 - High heel reinforcement
 - Ball of the foot reinforcement
 - Numbered
 - Ribbed

- Caractéristiques:**
- Tricot jambe anti-glissement
 - Haut du talon renforcé
 - Région du métatarse renforcé
 - Numérotée
 - À côte

- Caratteristiche:**
- Tubo antiscivolo
 - Caviglia rinforzata
 - Arco plantare rinforzato
 - Numerato
 - A coste

009



010**

290**

538**

73% Baumwolle / cotton
22% Polyamid
5% Elasthan (Lycra®)



Rohrer	Europe	US Men's
S	39 - 40	6 - 7½
M	41 - 42	8 - 8½
L	43 - 44	9 - 10
XL	45 - 46	10½ - 12

** – solange Vorrat

superR WO

10.064/1

merino wool



Season:



crew cut



Numero in copola • Piatwise nummeriert • numbered in pairs • numerotées par paire • Numerari in copiale • Numerari per parte



213

- Besonderheiten:**
- Verstärkte Hochferse
 - Ballenverstärkung
 - Gekettelt

- Eigenschaften:**
- Rutschfestes Rohr
 - Hochfersenverstärkung
 - Ballenverstärkung
 - Nummeriert
 - Gerippt
 - Geruchshemmend

- Specificities:**
- Reinforced high-heel
 - Ball of the foot reinforcement
 - Seamless

- Features:**
- Antislip tube
 - High heel reinforcement
 - Ball of the foot reinforcement
 - Numbered
 - Ribbed
 - Anti-odor

- Particularités:**
- Haut du talon renforcé
 - Coussinets plantaires renforcée
 - Remmaillée

- Caractéristiques:**
- Tricot jambe anti-glissement
 - Haut du talon renforcé
 - Région du métatarse renforcé
 - Numérotée
 - À côte
 - Anti-odeur

- Particolarità:**
- Tallone rinforzato di altezza maggiorata
 - Estremità del metatarso rinforzate
 - Punta rimagliata

- Caratteristiche:**
- Tubo antiscivolo
 - Caviglia rinforzata
 - Arco plantare rinforzato
 - Numerato
 - A coste
 - Antiodore



046 070* 058* 009* 181*** 461*** 463***

73% Woll (Merino) / Wool (Merino)
22% Polyamid
5% Elasthan (Lycra®)



Rohner	Europe	US Men's
S	39 - 40	6 - 7 1/2
M	41 - 42	8 - 8 1/2
L	43 - 44	9 - 10
XL	45 - 46	10 1/2 - 12
XXL*	47 - 48	12 1/2 - 13

XXL* – nur / only / seulement / solo col. 009 / 058 / 070
*** – Limited Edition

super WO long

10.064/3

merino wool



Nummeriert in coppia • paarweise nummeriert • numbered in pairs • numératees par paire • Numerate in coppia



Season:



over the calf



Besonderheiten:

- Verstärkte Hochferse
- Ballenverstärkung
- Gekettelt

Eigenschaften:

- Hochfersenverstärkung
- Ballenverstärkung
- Gerippt
- Nummeriert

Specificities:

- Reinforced high-heel
- Ball of the foot reinforcement
- Seamless

Features:

- High heel reinforcement
- Ball of the foot reinforcement
- Ribbed
- Numbered

Particularités:

- Haut du talon renforcé
- Coussinets plantaires renforcée
- Remmaillée

Caractéristiques:

- Haut du talon renforcé
- Région du métatarse renforcé
- À côte
- Numérotée

Particolarità:

- Tallone rinforzato di altezza maggiorata
- Estremità del metatarso rinforzate
- Punta rimagliata

Caratteristiche:

- Caviglia rinforzata
- Arco plantare rinforzato
- A coste
- Numerato



070**

213**

404**

492**

73% Wolle (Merino) / Wool (Merino)
22% Polyamid
5% Elasthan (Lycra®)



Rohner	Europe	US Men's
S	39 - 40	6 - 7 1/2
M	41 - 42	8 - 8 1/2
L	43 - 44	9 - 10
XL	45 - 46	10 1/2 - 12

** – solange Vorrat

platin

10.045/1

bamboo



Season:



crew cut



Numero in coppia • paarweise nummeriert • numbered in pair • numératees par paire • Numéroés par paire



135



Besonderheiten:

- Rutschfestes Rohr
- Gekettelt



Specificities:

- Antislip tube
- Seamless



Particularités:

- Tricot jambe anti-glissement
- Remmaillée



Particolarità:

- Tubo antiscivolo
- Punta rimagliata

Eigenschaften:

- Antibakteriell
- Geruchshemmend
- Antistatisch
- Rutschfestes Rohr
- Ballenverstärkung
- Nummeriert
- Natürliche Feuchtigkeitsregulierung
- Gerippt

Features:

- Antibacterial
- Anti-odor
- Antistatic
- Antislip tube
- Ball of the foot reinforcement
- Numbered
- Natural moisture management
- Ribbed

Caractéristiques:

- Antibactérienne
- Anti-odeur
- Antistatique
- Talon renforcé
- Région du métatarse renforcé
- Numérotée
- Gestion naturelle de l'humidité
- À côte

Caratteristiche:

- Antibatterico
- Antiodore
- Antistatico
- Tallone rinforzato
- Arco plantare rinforzato
- Numerato
- Gestione naturale dell'umidità
- A coste



60% Viskose (Bambus)
21% Polyamid
18% Polyamid (Meryl Skinlife®)
1% Elasthan (Lycra®)



Rohner	Europe	US Men's
S	39 - 40	6 - 7 1/2
M	41 - 42	8 - 8 1/2
L	43 - 44	9 - 10
XL	45 - 46	10 1/2 - 12
XXL*	47 - 48	12 1/2 - 13

XXL* – nur / only / seulement / solo col.009
** – solange Vorrat

platin long

10.045/3 *Solange Vorrat*

bamboo



Season:



over the calf

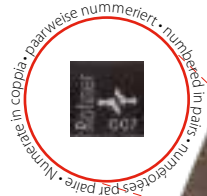

Besonderheiten:

- Rutschfestes Rohr
- Verstärkung der Hochferse und des Ballenbereichs
- Gekettelt



Specificities:

- Antislip tube
- High heel and ball of the foot reinforcement
- Seamless



Particularités:

- Tricot jambe anti-glisement
- Haut du talon et région du métatarse renforcés
- Remmaillée



Particolarità:

- Tubo antiscivolo
- Parte alta del tallone ed estremità del metatarso rinforzate
- Punta rimagliata

Eigenschaften:

- Antibakteriell
- Geruchshemmend
- Antistatisch
- Rutschfestes Rohr
- Hochferseverstärkung
- Ballenverstärkung
- Nummeriert
- Natürliche Feuchtigkeitsregulierung
- Gerippt

Features:

- Antibacterial
- Anti-odor
- Antistatic
- Antislip tube
- High heel reinforcement
- Ball of the foot reinforcement
- Numbered
- Natural moisture management
- Ribbed

Caractéristiques:

- Antibactérienne
- Anti-odeur
- Antistatique
- Talon renforcé
- Tricot jambe anti-glisement
- Région du métatarse renforcé
- Numérotée
- Gestion naturelle de l'humidité
- À côte

Caratteristiche:

- Antibatterico
- Antiodore
- Antistatico
- Tallone rinforzato
- Tubo antiscivolo
- Arco plantare rinforzato
- Numerato
- Gestione naturale dell'umidità
- A coste

047



135

010

009

60% Viskose (Bambus)
21% Polyamid
18% Polyamid (Meryl Skinlife®)
1% Elasthan (Lycra®)



Rohner	Europe	US Men's
S	39 - 40	6 - 7 1/2
M	41 - 42	8 - 8 1/2
L	43 - 44	9 - 10
XL	45 - 46	10 1/2 - 12

casual

10.259/1

wellness

Numero in coppia • paarweise nummeriert • number by pairs • numereados por pareja • Numéro en paire • Numéro en paire



009*



143**

047**



Besonderheiten:

- Verstärkte Hochferse
- Gekettelt

Eigenschaften:

- Antibakteriell
- Geruchshemmend
- Antistatisch
- Hochfersenverstärkung
- Fusskomfort
- Glatt
- Nummeriert



Specificities:

- Reinforced high-heel
- Seamless

Features:

- Antibacterial
- Anti-odor
- Antistatic
- High heel reinforcement
- Foot wellness
- Plain
- Numbered



Particularités:

- Haut du talon renforcé
- Remmaillée

Caractéristiques:

- Antibactérienne
- Anti-odeur
- Antistatique
- Haut du talon renforcé
- Bien-etre du pied
- Lisse
- Numérotée



Particolarità:

- Tallone rinforzato di altezza maggiorata
- Punta rimagliata

Caratteristiche:

- Antibatterico
- Antiodore
- Antistatico
- Caviglia rinforzata
- Benessere del piede
- Liscio
- Numerato



Season:

crew cut



51% Baumwolle / cotton
28% Polyamid
14% SeaCell®
7% Smartcel® Sensitive



Rohner	Europe	US Men's
S	39 - 40	6 - 7 1/2
M	41 - 42	8 - 8 1/2
L	43 - 44	9 - 10
XL	45 - 46	10 1/2 - 12
XXL*	47 - 48	12 1/2 - 13

XXL* – nur / only / seulement / solo col.009
** – solange Vorrat

napoli

10.262/1

3 layer technology



Season:



crew cut



numeriert • paarweise nummeriert • numbered in pairs • numeratores per paia • numerate in coppia



532

- Besonderheiten:**
- Verstärkte Hochferse
 - Gekettelt

- Specificities:**
- Reinforced high-heel
 - Seamless

- Particularités:**
- Haut du talon renforcé
 - Remmaillée

- Particolarità:**
- Tallone rinforzato di altezza maggiorata
 - Punta rimagliata

- Eigenschaften:**
- Hochfersenverstärkung
 - Für Schuhe mit Membranfutter
 - 3-Schichten-Technologie
 - Glatt
 - Nummeriert

- Features:**
- High heel reinforcement
 - For membran liner footwear
 - 3 layer technology
 - Plain
 - Numbered

- Caractéristiques:**
- Haut du talon renforcé
 - Pour chaussures doublées en membrane
 - Technologie triple couche
 - Lisse
 - Numérotée

- Caratteristiche:**
- Caviglia rinforzata
 - Per calzature con fodera interna
 - Tecnologia a 3 strati
 - Liscio
 - Numerato



290

009

366

75% Baumwolle / cotton
12% Polyester (Dacron®)
12% Polyamid
1% Elasthan (Lykra®)



Rohner	Europe	US Men's
S/M	39 - 42	6 - 8½
L/XL	43 - 46	9 - 11

premium

10.427/1 *Solange Vorrat*

cashmere | silk

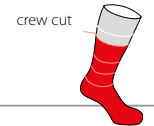

064



Besonderheiten:

- Gekettelt



Specificities:

- Seamless



Particularités:

- Remmaillée



Particolarità:

- Punta rimagliata

Eigenschaften:

- Natürliche Thermoregulierung
- Glatt

Features:

- Natural thermo control
- Plain

Caractéristiques:

- Régulation thermique naturelle
- Lisse

Caratteristiche:

- Termoregolazione naturale
- Liscio



009

213

329

56% Kaschmir / cashmere
24% Seide / silk
20% Polyamid



Rohner	Europe	US Men's
S	39 - 40	6 - 7½
M	41 - 42	8 - 8½
L	43 - 44	9 - 10
XL	45 - 46	10½ - 12

diamond

10.420/1 *Limited Edition*

bamboo

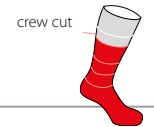

Nummeriert in Paarweise • Paarweise nummeriert • numbered in pairs • numerotées par paires



- Besonderheiten:**
- Weicher Abschlussrand
 - Verstärkung der Ferse, Hochferse und des Ballenbereichs
 - Gekettelt

- Specificities:**
- Soft border
 - High heel, heel and ball of the foot reinforcement
 - Hand-linked

- Particularités:**
- Bords non comprimants
 - Haut du talon, talon et région du métatarse renforcés
 - Remmaillée

- Particolarità:**
- Bordo in tessuto morbido
 - Parte alta del tallone, tallone ed estremità del metatarso rinforzati
 - Punta rimagliata a mano

- Eigenschaften:**
- Antibakteriell
 - Geruchshemmend
 - Antistatisch
 - Fersenverstärkung
 - Hochfersenverstärkung
 - Ballenverstärkung
 - Nummeriert
 - Natürliche Feuchtigkeitsregulierung
 - Glatt

- Features:**
- Antibacterial
 - Anti-odor
 - Antistatic
 - Heel reinforcement
 - High heel reinforcement
 - Ball of the foot reinforcement
 - Numbered
 - Natural moisture management
 - Plain

- Caractéristiques:**
- Antibactérienne
 - Anti-odeur
 - Antistatique
 - Talon renforcé
 - Haut du talon renforcé
 - Région du métatarse renforcé
 - Numérotée
 - Gestion naturelle de l'humidité
 - Lisse

- Caratteristiche:**
- Antibatterico
 - Antiodore
 - Antistatico
 - Tallone rinforzato
 - Caviglia rinforzata
 - Arco plantare rinforzato
 - Numerato
 - Gestione naturale dell'umidità
 - Liscio

009*



135

047

65% Viskose (Bambus)
24% Polyamid (Meryl Skinlife®)
10% Polyamid
1% Elasthan (Lycra®)



Rohner	Europe	US Men's
S	39 - 40	6 - 7 1/2
M	41 - 42	8 - 8 1/2
L	43 - 44	9 - 10
XL	45 - 46	10 1/2 - 12
XXL*	47 - 48	12 1/2 - 13

XXL* – nur / only / seulement / solo col. 009

diamond long

10.420/3 *Limited Edition*

bamboo

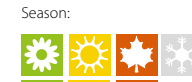
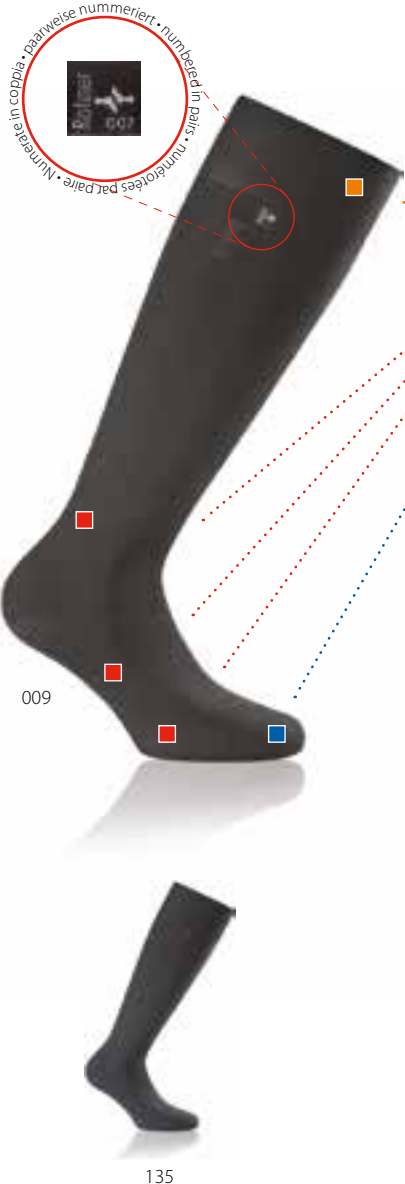

Season: over the calf



Besonderheiten:

- Weicher Abschlussrand
- Verstärkung der Ferse, Hochferse und des Ballenbereichs
- Gekettelt

Specificities:

- Soft border
- High heel, heel and ball of the foot reinforcement
- Hand-linked

Particularités:

- Bords non comprimants
- Haut du talon, talon et région du métatarse renforcés
- Remmaillée

Particolarità:

- Bordo in tessuto morbido
- Parte alta del tallone, tallone ed estremità del metatarso rinforzati
- Punta rimagliata a mano

Eigenschaften:

- Antibakteriell
- Geruchshemmend
- Antistatisch
- Fersenverstärkung
- Hochferseverstärkung
- Ballenverstärkung
- Nummeriert
- Natürliche Feuchtigkeitsregulierung
- Glatt

Features:

- Antibacterial
- Anti-odor
- Antistatic
- Heel reinforcement
- High heel reinforcement
- Ball of the foot reinforcement
- Numbered
- Natural moisture management
- Plain

Caractéristiques:

- Antibactérienne
- Anti-odeur
- Antistatique
- Talon renforcé
- Haut du talon renforcé
- Région du métatarse renforcé
- Numérotée
- Gestion naturelle de l'humidité
- Lisse

Caratteristiche:

- Antibatterico
- Antiodore
- Antistatico
- Tallone rinforzato
- Caviglia rinforzata
- Arco plantare rinforzato
- Numerato
- Gestione naturale dell'umidità
- Liscio

009

135

65% Viskose (Bambus)
24% Polyamid (Meryl Skinlife®)
10% Polyamid
1% Elasthan (Lycra®)



Rohner	Europe	US Men's
S	39 - 40	6 - 7 1/2
M	41 - 42	8 - 8 1/2
L	43 - 44	9 - 10
XL	45 - 46	10 1/2 - 12

london

10.299/1

cashmere

Season:



crew cut

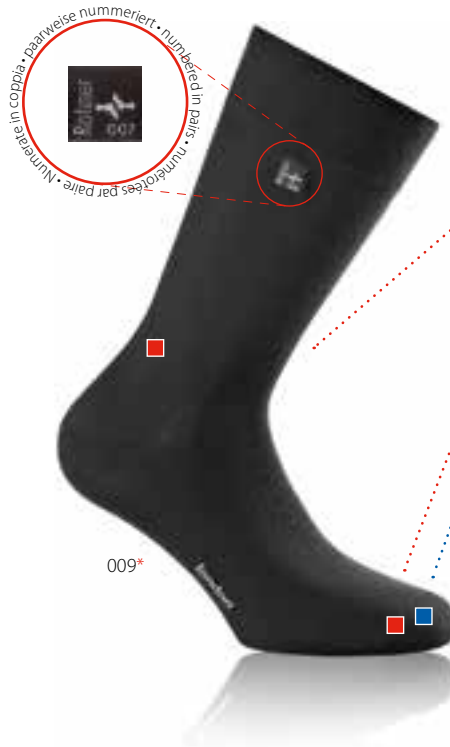

Besonderheiten:

- Verstärkung der Hochferse und des Zehenbereichs
- Gekettelt



Specificities:

- High heel and toe reinforcement
- Seamless



Particularités:

- Haut du talon et région des orteils renforcés
- Remmaillée



Particolarità:

- Parte alta del tallone e punta rinforzate
- Punta rimagliata

Eigenschaften:

- Hochfersenverstärkung
- Nummeriert
- Glatt

Features:

- High heel reinforcement
- Numbered
- Plain

Caractéristiques:

- Haut du talon renforcé
- Numérotée
- Lisse

Caratteristiche:

- Caviglia rinforzata
- Numerato
- Liscio

63% Baumwolle / cotton
24% Polyamid
11% Kaschmir / cashmere
2% Elasthan (Lycra®)



Rohner	Europe	US Men's
S	39 - 40	6 - 7 1/2
M	41 - 42	8 - 8 1/2
L	43 - 44	9 - 10
XL	45 - 46	10 1/2 - 12
XXL*	47 - 48	12 1/2 - 13

XXL* - nur / only / seulement / solo col. 009

yverdon

10.399/1 *Limited Edition*

wellness

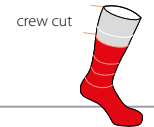

Nummeriert in Paaren • pairweise nummeriert • numbered in pairs • numératees par paire



009

- Besonderheiten:**
- Weicher Abschlussrand
 - Rutschfestes Rohr
 - Keine Druckstellen
 - Gekettelt

- Specificities:**
- Soft border
 - Antislip tube
 - No pressure points
 - Seamless

- Particularités:**
- Bords non comprimants
 - Tricot jambe anti-glisement
 - Chaussettes non comprimantes
 - Remmaillée

- Particolarità:**
- Bordo in tessuto morbido
 - Tubo antiscivolo
 - Senza punti di pressione
 - Punta rimagliata

- Eigenschaften:**
- Antibakteriell
 - Geruchshemmend
 - Antistatisch
 - Fusskomfort
 - Nummeriert
 - Gerippt

- Features:**
- Antibacterial
 - Anti-odor
 - Antistatic
 - Foot wellness
 - Numbered
 - Ribbed

- Caractéristiques:**
- Antibactérienne
 - Anti-odeur
 - Antistatique
 - Bien-être du pied
 - Numérotée
 - À côte

- Caratteristiche:**
- Antibatterico
 - Antiodore
 - Antistatico
 - Benessere del piede
 - Numerato
 - A coste



143



135

64% Baumwolle / cotton
13% Polyamid
12% SeaCell®
6% Smartcel® Sensitive
5% Crabyon®



Rohrer	Europe	US Men's
S	36 - 38	3 - 5 1/2
M	39 - 41	6 - 8
L	42 - 44	8 1/2 - 10
XL	45 - 46	10 1/2 - 12
XXL	47 - 48	12 1/2 - 13

titanium

10.426/1 *Limited Edition*

merino | silk

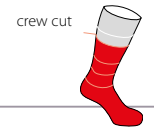

- Besonderheiten:**
- Weicher Abschlussrand
 - Verstärkung der Ferse, Hochferse und des Ballenbereichs
 - Gekettelt

- Specificities:**
- Soft border
 - High heel, heel and ball of the foot reinforcement
 - Seamless

- Particularités:**
- Bords non comprimants
 - Haut du talon, talon et région du métatarse renforcés
 - Remmaillée

- Particolarità:**
- Bordo in tessuto morbido
 - Parte alta del tallone, tallone ed estremità del metatarso rinforzati
 - Punta rimagliata

- Eigenschaften:**
- Antibakteriell
 - Geruchshemmend
 - Antistatisch
 - Fersenverstärkung
 - Hochfernenverstärkung
 - Ballenverstärkung
 - Nummeriert
 - Natürliche Thermoregulierung
 - Glatt

- Features:**
- Antibacterial
 - Anti-odor
 - Antistatic
 - Heel reinforcement
 - High heel reinforcement
 - Ball of the foot reinforcement
 - Numbered
 - Natural thermo control
 - Plain

- Caractéristiques:**
- Antibactérienne
 - Anti-odeur
 - Antistatique
 - Talon renforcé
 - Haut du talon renforcé
 - Région du métatarse renforcé
 - Numérotée
 - Régulation thermique naturelle
 - Lisse

- Caratteristiche:**
- Antibatterico
 - Antiodore
 - Antistatico
 - Tallone rinforzato
 - Caviglia rinforzata
 - Arco plantare rinforzato
 - Numerato
 - Termoregolazione naturale
 - Liscio

009*



135

44% Wolle (Merino) / Wool (Merino)
 20% Polyamid
 19% Polyamid (Silberionen*)
 14% Seide / silk
 3% Elasthan (Lycra®)



silver

Rohner	Europe	US Men's
S	39 - 40	6 - 7 1/2
M	41 - 42	8 - 8 1/2
L	43 - 44	9 - 10
XL	45 - 46	10 1/2 - 12
XXL*	47 - 48	12 1/2 - 13

XXL* - nur / only / seulement / solo col. 009

delémont

10.347/1

micro modal

Season:



crew cut



Nummeriert
• Numérotés par paire
• Numerierte Paarweise
• Numeriert in coppia

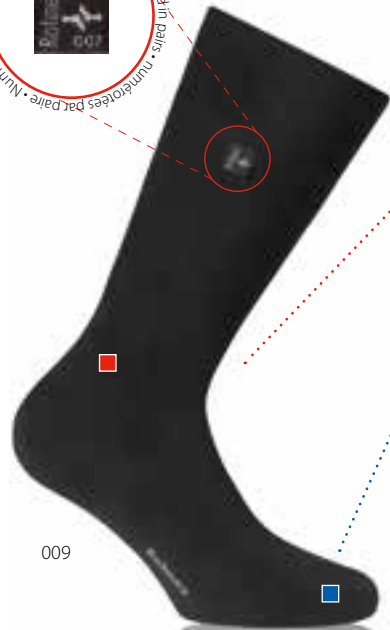

009



Besonderheiten:

- Verstärkung der Hochferse und des Ballenbereichs
- Gekettelt



Specificities:

- High heel and ball of the foot reinforcement
- Seamless



Particularités:

- Haut du talon et région du métatarse renforcés
- Remmaillée



Particolarità:

- Parte alta del tallone ed estremità del metatarso rinforzati
- Punta rimagliata

Eigenschaften:

- Feuchtigkeitsregulierung
- Glatt
- Nummeriert

Features:

- Moisture Management
- Plain
- Numbered

Caractéristiques:

- Gestion de l'humidité
- Lisse
- Numérotée

Caratteristiche:

- Gestione dell'umidità
- Liscio
- Numerato



135

400**

561**

042**

076**

68% SwissModal® Micro
30% Polyamid
2% Elasthan (Lycra®)



Rohner	Europe	US Men's
S	39 - 40	6 - 7 1/2
M	41 - 42	8 - 8 1/2
L	43 - 44	9 - 10
XL	45 - 46	10 1/2 - 12

** - solange Vorrat

verona

10.174/1 *Solange Vorrat*

cotton

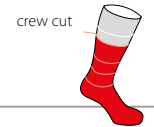

290

Besonderheiten:
■ Gekettelt

Specificities:
■ Seamless

Particularités:
■ Remmaillée

Particolarità:
■ Punta rimagliata

Eigenschaften:
■ Gekettelt
■ Glatt

Features:
■ Seamless
■ Plain

Caractéristiques:
■ Remmaillée
■ Lisse

Caratteristiche:
■ Punta rimagliata
■ Liscio



532

070

009

95% Baumwolle / cotton
3% Polyamid
2% Elasthan (Lycra®)



Rohner	Europe	US Men's
S/M	39 - 42	6 - 8 1/2
L/XL	43 - 46	9 - 11

bergamo

10.020/1 *Solange Vorrat*

100% cotton

Season:



crew cut



Numero in coppia • paarweise nummeriert • numbered in pairs • numérotés par paire • Numerate in coppia • paarweise nummeriert • numbered in pairs • numérotés par paire



320



Besonderheiten:

- Verstärkte Hochferse
- Gekettelt



Specificities:

- Reinforced high-heel
- Seamless



Particularités:

- Haut du talon renforcé
- Remmaillée



Particolarità:

- Tallone rinforzato di altezza maggiorata
- Punta rimagliata

Eigenschaften:

- Hochfersenverstärkung
- Gerippt
- Nummeriert

Features:

- High heel reinforcement
- Ribbed
- Numbered

Caractéristiques:

- Haut du talon renforcé
- À côte
- Numérotée

Caratteristiche:

- Caviglia rinforzata
- A coste
- Numerato

100% Baumwolle / cotton

Rohner	Europe	US Men's
S	39 - 40	6 - 7 1/2
M	41 - 42	8 - 8 1/2
L	43 - 44	9 - 10
XL	45 - 46	10 1/2 - 12
XXL*	47 - 48	12 1/2 - 13

capri

10.291/1

cotton

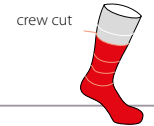

in coppia • paarweise nummeriert • numbered in pairs • numératees par paire • Numerate in coppia • paarweise nummeriert • numbered in pairs • numératees par paire



009



135



070**



Besonderheiten:

- Gekettelt



Specificities:

- Seamless



Particularités:

- Remmaillée



Particolarità:

- Punta rimagliata

Eigenschaften:

- Pique-Struktur
- Nummeriert

Features:

- Piqué structure
- Numbered

Caractéristiques:

- Structure de piqué
- Numérotée

Caratteristiche:

- Struttura piqué
- Numerato

80% Baumwolle / cotton
20% Polyamid

Rohrer	Europe	US Men's
S	39 - 40	6 - 7 1/2
M	41 - 42	8 - 8 1/2
L	43 - 44	9 - 10
XL	45 - 46	10 1/2 - 12

** – solange Vorrat

compression everyday

10.290/3

energy socks



Season:



over the calf



Besonderheiten:

- Degressive Kompression
- Gekettelt



Specificities:

- Pressure reduction
- Seamless



Particularités:

- Compression dégressive
- Remmaillée



Particolarità:

- Tecnologia di riduzione a pressione degressiva
- Punta rimagliata

Hauptvorteil:

- Kompression

Entwickelt für:

- Alltag
- Reisen

Sport / Verwendung:

- Arbeiten
- Reisen

Eigenschaften:

- Verbesserte arterielle Durchblutung im Bein
- Präventiv und Regenerativ

Main Benefit:

- Compression

Designed For:

- Everyday
- Travel

Sports / Use:

- Working
- Travel

Features:

- Improved arterial circulation in the legs
- Preventative and regenerative

Principal avantage:

- Compression

Conçue pour:

- Activités quotidiennes
- Voyage

Sports / Utilisations:

- Travail
- Voyage

Caractéristiques:

- Meilleure circulation artérielle de la jambe
- Préventif et régénératif

Vantaggio principale:

- Compressione

Progettato per:

- Uso quotidiano
- Viaggio

Sport / Uso:

- Lavoro
- Viaggio

Caratteristiche:

- Migliore circolazione arteriosa della gamba
- Per prevenzione e recupero

009

59% Baumwolle / cotton
31% Polyamid
10% Elasthan (Lycra®)



Rohner	Europe	US Men's
S	36 - 38	3 - 5 1/2
M	39 - 41	6 - 8
L	42 - 44	8 1/2 - 10
XL	44 - 46	10 - 12

Business Women

Schritt für Schritt durch den Alltag



sydney

30.025/2 *Solange Vorrat*

wellness

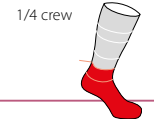

- Besonderheiten:**
- Verstärkte Hochferse
 - Gekettelt

- Specificities:**
- Reinforced high-heel
 - Seamless

- Particularités:**
- Haut du talon renforcé
 - Remmaillée

- Particolarità:**
- Tallone rinforzato di altezza maggiorata
 - Punta rimagliata

- Eigenschaften:**
- Antibakteriell
 - Geruchshemmend
 - Hochfersenverstärkung
 - Fusskomfort
 - Glatt

- Features:**
- Antibacterial
 - Anti-odor
 - High heel reinforcement
 - Foot wellness
 - Plain

- Caractéristiques:**
- Antibactérienne
 - Anti-odeur
 - Haut du talon renforcé
 - Bien-être du pied
 - Lisse

- Caratteristiche:**
- Antibatterico
 - Antiodore
 - Caviglia rinforzata
 - Benessere del piede
 - Liscio



002



010

009

52% Baumwolle / cotton
26% Polyamid
15% SeaCell®
7% Smartcel® Sensitive



Rohner	Europe	US Women
S	35 - 38	4 - 6 1/2
M	39 - 42	7 1/2 - 10

superR BW women

30.024/1

cotton



Season:



crew cut



Numero in coppia - paarweise nummeriert - numbered in pairs - numerotées par paire - Numerele in coppia

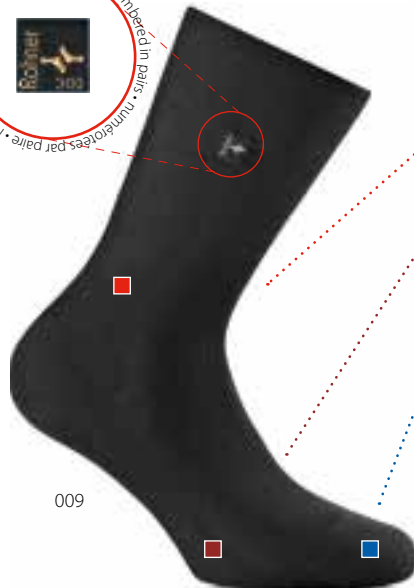

009

Besonderheiten:

- Verstärkte Hochferse
- Ballenverstärkung
- Gekettelt

Eigenschaften:

- Rutschfestes Rohr
- Hochfersenverstärkung
- Ballenverstärkung
- Nummeriert
- Gerippt

Specificities:

- Reinforced high-heel
- Ball of the foot reinforcement
- Seamless

Features:

- Antislip tube
- High heel reinforcement
- Ball of the foot reinforcement
- Numbered
- Ribbed

Particularités:

- Haut du talon renforcé
- Coussinets plantaires renforcée
- Remmaillée

Caractéristiques:

- Tricot jambe anti-glisserment
- Haut du talon renforcé
- Région du métatarse renforcé
- Numérotée
- À côte

Particolarità:

- Tallone rinforzato di altezza maggiorata
- Estremità del metatarso rinforzati
- Punta rimagliata

Caratteristiche:

- Tubo antiscivolo
- Caviglia rinforzata
- Arco plantare rinforzato
- Numerato
- A coste



008

010

73% Baumwolle / cotton
22% Polyamid
5% Elasthan (Lycra®)



Rohner	Europe	USWomen
S	35 - 38	4 - 6 1/2
M	39 - 42	7 1/2 - 10

super WO women

30.065/1

merino wool



Season:



crew cut



Numero in coppia • Paarweise nummeriert • numbered in pairs • Numero in coppia • Numéro en paire



009



070

090**

Besonderheiten:

- Verstärkte Hochferse
- Ballenverstärkung
- Gekettelt

Eigenschaften:

- Rutschfestes Rohr
- Hochfersenverstärkung
- Ballenverstärkung
- Nummeriert
- Gerippt
- Geruchshemmend

Specificities:

- Reinforced high-heel
- Ball of the foot reinforcement
- Seamless

Features:

- Antislip tube
- High heel reinforcement
- Ball of the foot reinforcement
- Numbered
- Ribbed
- Anti-odor

Particularités:

- Haut du talon renforcé
- Coussinets plantaires renforcée
- Remmaillée

Caractéristiques:

- Tricot jambe anti-glisserment
- Haut du talon renforcé
- Région du métatarse renforcé
- Numérotée
- À côte
- Anti-odeur

Particolarità:

- Tallone rinforzato di altezza maggiorata
- Estremità del metatarso rinforzate
- Punta rimagliata

Caratteristiche:

- Tubo antiscivolo
- Caviglia rinforzata
- Arco plantare rinforzato
- Numerato
- A coste
- Antiodore

73% Wolle (Merino) / Wool (Merino)
22% Polyamid
5% Elasthan (Lycra®)



Rohner	Europe	US Women
S	35 - 38	4 - 6 1/2
M	39 - 42	7 1/2 - 10

** - solange Vorrat

platin women

30.045/1

bamboo



Season:



crew cut



Numero in coppia • Paarweise nummeriert • Numbered in pairs • numérate în perechi • Numérotes par paire • Numerate in coppia

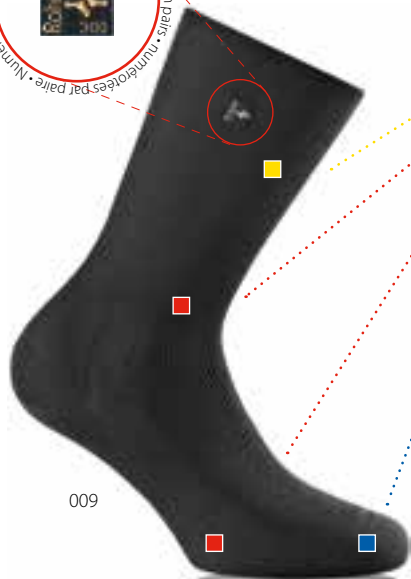

009



008**

- Besonderheiten:**
- Rutschfestes Rohr
 - Verstärkung der Hochferse und des Ballenbereichs
 - Gekettelt

Eigenschaften:

- Antibakteriell
- Geruchshemmend
- Antistatisch
- Rutschfestes Rohr
- Hochferseverstärkung
- Ballenverstärkung
- Nummeriert
- Natürliche Thermoregulierung
- Gerippt

- Specificities:**
- Antislip tube
 - High heel and ball of the foot reinforcement
 - Seamless

Features:

- Antibacterial
- Anti-odor
- Antistatic
- Antislip tube
- High heel reinforcement
- Ball of the foot reinforcement
- Numbered
- Natural thermo control
- Ribbed

- Particularités:**
- Tricot jambe anti-glisement
 - Haut du talon et région du métatarse renforcés
 - Remmaillée

Caractéristiques:

- Antibactérienne
- Anti-odeur
- Antistatique
- Tricot jambe anti-glisement
- Haut du talon renforcé
- Région du métatarse renforcé
- Numérotée
- Régulation thermique naturelle
- À côte

- Particolarità:**
- Tubo antiscivolo
 - Parte alta del tallone ed estremità del metatarso rinforzati
 - Punta rimagliata

Caratteristiche:

- Antibatterico
- Antiodore
- Antistatico
- Tubo antiscivolo
- Caviglia rinforzata
- Arco plantare rinforzato
- Numerato
- Termoregolazione naturale
- A coste

60% Viskose (Bambus)
21% Polyamid
18% Polyamid (Meryl Skinlife®)
1% Elasthan (Lycra®)



Rohner	Europe	US Women
S	35 - 38	4 - 6 1/2
M	39 - 42	7 1/2 - 10

** - solange Vorrat

premium women

30.427/1 *Solange Vorrat*

cashmere | silk

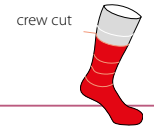

Besonderheiten:

- Gekettelt



Specificities:

- Seamless



Particularités:

- Remmaillée



Particolarità:

- Punta rimagliata

Eigenschaften:

- Natürliche Thermoregulierung
- Glatt

Features:

- Natural thermo control
- Plain

Caractéristiques:

- Régulation thermique naturelle
- Lisse

Caratteristiche:

- Termoregolazione naturale
- Liscio



009

56% Kaschmir / cashmere
24% Seide / silk
20% Polyamid



Rohner	Europe	US Women
S	35 - 38	4 - 6½
M	39 - 42	7½ - 10

diamond women

30.420/1 *Limited Edition*

bamboo

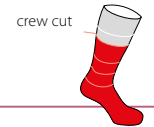

Numero in coppia, pairwise numeriert, numbered in pairs, numératees par paire, numeratees par paire

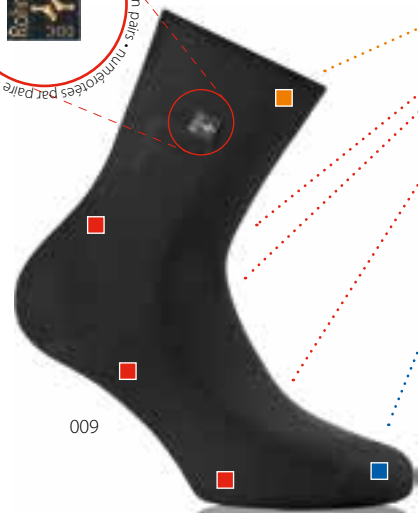

009

Besonderheiten:

- Weicher Abschlussrand
- Verstärkung der Ferse, Hochferse und des Ballenbereichs
- Gekettelt

Specificities:

- Soft border
- High heel, heel and ball of the foot reinforcement
- Seamless

Particularités:

- Bords non comprimants
- Haut du talon, talon et région du métatarse renforcés
- Remmaillée

Particolarità:

- Bordo in tessuto morbido
- Parte alta del tallone, tallone ed estremità del metatarso rinforzati
- Punta rimagliata

Eigenschaften:

- Antibakteriell
- Geruchshemmend
- Antistatisch
- Fersenverstärkung
- Hochferseverstärkung
- Ballenverstärkung
- Nummeriert
- Natürliche Feuchtigkeitsregulierung
- Glatt

Features:

- Antibacterial
- Anti-odor
- Antistatic
- Heel reinforcement
- High heel reinforcement
- Ball of the foot reinforcement
- Numbered
- Natural moisture management
- Plain

Caractéristiques:

- Antibactérienne
- Anti-odeur
- Antistatique
- Talon renforcé
- Haut du talon renforcé
- Région du métatarse renforcé
- Numérotée
- Gestion naturelle de l'humidité
- Lisse

Caratteristiche:

- Antibatterico
- Antiodore
- Antistatico
- Tallone rinforzato
- Caviglia rinforzata
- Arco plantare rinforzato
- Numerato
- Gestione naturale dell'umidità
- Liscio



008

010

65% Viskose (Bambus)
24% Polyamid (Meryl Skinlife®)
10% Polyamid
1% Elasthan (Lycra®)



Rohner	Europe	US Women
S	35 - 38	4 - 6 1/2
M	39 - 42	7 1/2 - 10

london women

30.299/1 *Solange Vorrat*

cashmere

Season:



crew cut



Numero in coppia - paarweise nummeriert - numbered in pairs - numerotés en paires - numerotés par paire

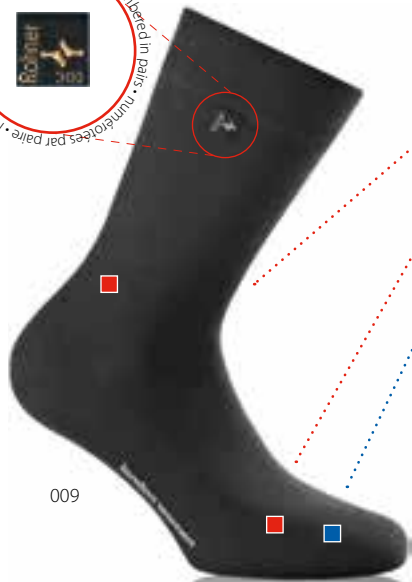

009



135

Besonderheiten:

- Verstärkung der Hochferse und des Zehenbereichs
- Gekettelt

Eigenschaften:

- Hochfersenverstärkung
- Nummeriert
- Natürliche Feuchtigkeitsregulierung
- Glatt

Specificities:

- High heel and toe reinforcement
- Seamless

Features:

- High heel reinforcement
- Numbered
- Natural moisture management
- Plain

Particularités:

- Haut du talon et région des orteils renforcés
- Remmaillée

Caractéristiques:

- Haut du talon renforcé
- Numérotée
- Gestion naturelle de l'humidité
- Lisse

Particolarità:

- Parte alta del tallone e punta rinforzate
- Punta rimagliata

Caratteristiche:

- Caviglia Rinforzata
- Numerato
- Gestione naturale nell'umidità
- Liscio

63% Baumwolle / cotton
24% Polyamid
11% Kaschmir / cashmere
2% Elasthan (Lycra®)



Rohner	Europe	US Women
S	35 - 38	4 - 6 1/2
M	39 - 42	7 1/2 - 10

delémont women

30.347/1 *Solange Vorrat*

micro modal

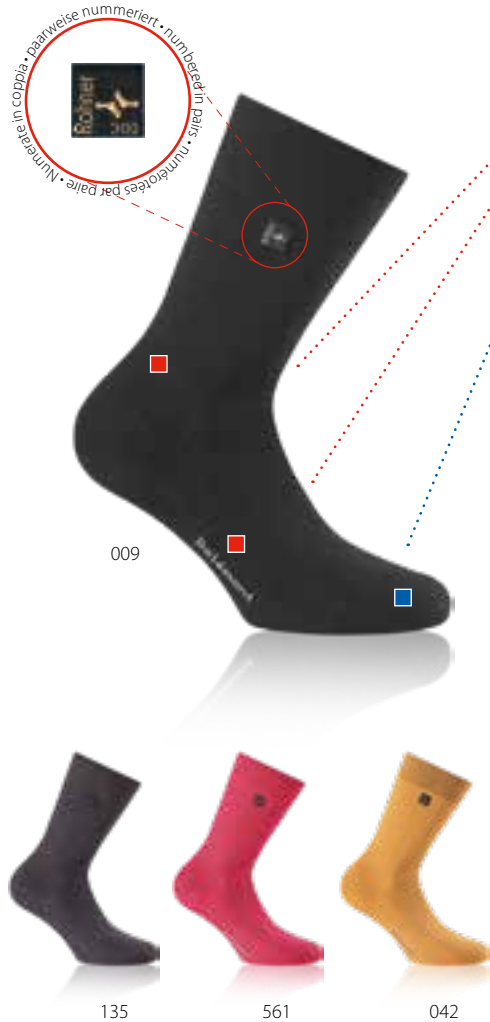
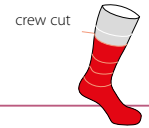
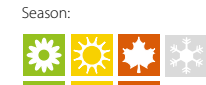

Besonderheiten:

- Verstärkung der Hochferse und des Ballenbereichs
- Gekettelt

Specificities:

- High heel and ball of the foot reinforcement
- Seamless

Particularités:

- Haut du talon et région du métatarse renforcés
- Remmaillée

Particolarità:

- Parte alta del tallone ed estremità del metatarso rinforzate
- Punta rimagliata

Eigenschaften:

- Feuchtigkeitsregulierung
- Glatt
- Nummeriert

Features:

- Moisture Management
- Plain
- Numbered

Caractéristiques:

- Gestion de l'humidité
- Lisse
- Numérotée

Caratteristiche:

- Gestione dell'umidità
- Liscio
- Numerato

68% SwissModal® Micro
30% Polyamid
2% Elasthan (Lycra®)



Rohner	Europe	USWomen
S	35 - 38	4 - 6 1/2
M	39 - 42	7 1/2 - 10

Compression

zu mehr Leistung dank Forschung



**compression
ski light l/r**

62.249/3
Ski / Snowboard

Seite 29



**compression
outdoor light**

60.250/3
Trekking

Seite 46



**compression
r-power l/r**

62.245/3
Running

Seite 56

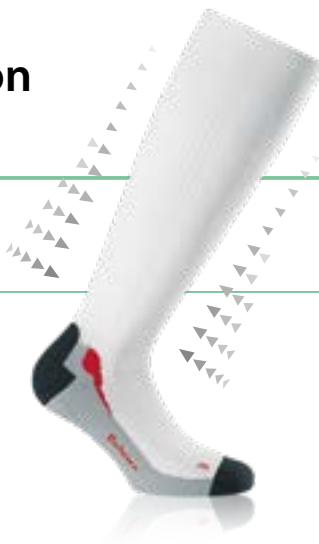

**compression
everyday**

10.290/3
Business Men

Seite 102



Health Care

das Leben problemlos geniessen



diabetic socks

10.421/1



Standard Grösse

Season:



crew cut



diabetic socks

Standard Grösse
standard tube
taille standard
misura standard



009

diabetic socks wide

10.422/1



extra weites Rohr

Season:



crew cut



extra weites Rohr
extra wide tube
tube extra large
misura larga



009



Hauptvorteil:

- Keine Druckstellen

Entwickelt für:

- Diabetiker

Sport / Verwendung:

- Medizinische Zwecke

Eigenschaften:

- Antibakteriell
- Geruchshemmend
- Antistatisch
- Fuss-Wellness
- Weicher Abschlussrand



Main Benefit:

- No pressure points

Designed For:

- Diabetic

Sports / Use:

- Medical intention

Features:

- Antibacterial
- Anti-odor
- Antistatic
- Foot wellness
- Soft border



Principal avantage:

- Chaussettes non comprimantes

Conçue pour:

- Diabétiques

Sports / Utilisations:

- Secteur médical

Caractéristiques:

- Antibactérienne
- Anti-odeur
- Antistatique
- Bien-être du pied
- Bord souple



Vantaggio principale:

- Neutralizzando gli inconvenienti da pressione

Progettato per:

- Diabetici

Sport / Uso:

- Uso medicale

Caratteristiche:

- Antibatterico
- Antiodore
- Antistatico
- Benessere del piede
- Bordo morbido

64% Baumwolle / cotton
13% Polyamid
12% SeaCell®
6% Smartcel® Sensitive
5% Crabyon®



Rohrer	Europe	US Men's	US Women
S	36 - 38	3 - 5 1/2	4 1/2 - 6 1/2
M	39 - 41	6 - 8	7 1/2 - 9 1/2
L	42 - 44	8 1/2 - 10	10 - 11 1/2
XL	45 - 46	10 1/2 - 12	-
XXL	47 - 48	12 1/2 - 13	-

diabetic wool socks

10.424/1 *Solange Vorrat*



Standard Grösse

Season:



crew cut



diabetic socks

Standard Grösse
standard tube
taille standard
misura standard



009

diabetic wool socks wide

10.425/1 *Solange Vorrat*



extra weites Rohr

Season:



crew cut



extra weites Rohr
extra wide tube
tube extra large
misura larga



009



Hauptvorteil:

- Keine Druckstellen

Entwickelt für:

- Diabetiker

Sport / Verwendung:

- Medizinische Zwecke

Eigenschaften:

- Weicher Abschlussrand



Main Benefit:

- No pressure points

Designed For:

- Diabetic

Sports / Use:

- Medical intention

Features:

- Soft border



Principal avantage:

- Chaussettes non comprimantes

Conçue pour:

- Diabétiques

Sports / Utilisations:

- Secteur médical

Caractéristiques:

- Bord souple



Vantaggio principale:

- Assenza di punti di pressione

Progettato per:

- Diabetici

Sport / Uso:

- Usò medicale

Caratteristiche:

- Bordo morbido

68% Wolle (Merino) / Wool (Merino)
30% Polyamid
2% Elasthan (Lycra®)





Rohner	Europe	US Men's	US Women
S	36 - 38	3 - 5½	4½ - 6½
M	39 - 41	6 - 8	7½ - 9½
L	42 - 44	8½ - 10	10 - 11½
XL	45 - 46	10½ - 12	-
XXL	47 - 48	12½ - 13	-



 Die Bambusfaser kann in hohem Masse Feuchtigkeit absorbieren, ohne dass sie sich feucht anfühlt. Die Bambusfaser ist daher erfrischend, atmungsaktiv, temperaturausgleichend und dank ihrer antibakteriellen Wirkung auch geruchshemmend.

 Bamboo fibre can absorb a high level of moisture, without feeling damp. Bamboo fibre is therefore refreshing, breathable, temperature regulating and – thanks to its anti-bacterial properties – also odour-inhibiting.

 Les fibres de bambou peuvent absorber énormément d'humidité sans donner la sensation d'être humides. C'est pourquoi les fibres de bambou sont rafraîchissantes, respirantes, thermocompensatrices et aussi inhibitrices d'odeurs grâce à leur effet antibactérien.

 La fibra di bambù può assorbire umidità in grande quantità, senza che sia umida al tatto. La fibra di bambù è quindi rinfrescante, traspirante, termoregolatrice e, grazie al suo effetto antibatterico, anche antiodore.



 Bio Baumwolle – Sie erkennen die Bio-Socken von Rohner am Bio Baumwolle-Logo. Bei der Herstellung dieser Socken wird hochwertige organische Baumwolle eingesetzt, die nach strengen Umwelt-Vorschriften biologisch angebaut wird. Bio-Socken von Rohner dürfen also mit Recht als «völlig natürlich» bezeichnet werden.

 Bio Baumwolle – Bio Socks from Rohner are recognisable by the Bio Baumwolle logo. These socks are made from high-quality organic cotton, grown in accordance with organic farming concepts and stringent environmental guidelines. Rohner Bio Socks can therefore rightfully be called the «natural option».

 Coton biologique – Vous reconnaîtrez les bio-chaussettes Rohner à leur logo «Coton biologique». Fabriquées à partir de coton organique haut de gamme issu de l'agriculture biologique contrôlée, ces chaussettes respectent les directives environnementales les plus rigoureuses qui soient. Les bio-chaussettes Rohner méritent donc pleinement l'appellation «cent pour cent naturelles!»

 Le calze Rohner in fibra di cotone ecologico sono contrassegnate dal logo Bio Baumwolle. Questa linea propone calze prodotte con cotone ecologico di alta qualità, proveniente da coltivazioni biologiche certificate secondo severi criteri di tutela ambientale. Le calze Rohner in fibra di cotone ecologico possono quindi fregiarsi a buon diritto del predicato di «semplicemente naturali».

BIOKERAMIK



 Biokeramik – Die biokeramische Faser ist in der Lage, Infrarot-Wärme aufzunehmen und gleichmäßig wieder abzugeben. Diese wirkt geruchshemmend und antibakteriell. Bei Erwärmung produziert sie negative Ionen. Negative Ionen werden auch als «Vitamine der Luft» bezeichnet. Man findet sie hauptsächlich an Wasserfällen, in Wäldern oder in den Bergen. Man bezeichnet sie aufgrund Ihrer positiven Auswirkungen auf die Stimmung, die Energie und das Wohlbefinden auch als gute oder glückliche Ionen.

 Bioceramic – The Bioceramic fibers get the capability to absorb and release infrared heat. These fibers also have an anti-odor and anti-bacterial effect and produce negative ions under the effect of heat. Negative ions are also known as «air vitamins» and, as an example, can be found in the vicinity of waterfalls, forests or mountains. Because of their positive influence on mood, vitality and well-being, negative ions are also called good ions or happy ions.

 Biocéramique – La fibre biocéramique est en mesure d'absorber la chaleur infrarouge et de la restituer régulièrement. Elle est désodorisante et antibactérienne. Si elle est chauffée, elle produit des ions négatifs. Les ions négatifs sont aussi appelés les «vitamines de l'air». On les trouve principalement près de cascades, dans des forêts ou en montagne. En raison de leurs effets positifs sur l'humeur, l'énergie et le bien-être, on les appelle aussi les ions heureux ou bons.

 Bioceramica – La fibra bioceramica è in grado di assumere e rilasciare di nuovo, in modo uniforme, calore infrarosso. Ciò ha un effetto antibatterico e antiodore. In caso di riscaldamento produce ioni negativi. Gli ioni negativi sono anche chiamati «vitamine per l'aria». Li si trova principalmente in cascate, boschi o in montagna. Sono anche chiamati ioni buoni o fortunati a causa degli effetti positivi sullo stato d'animo, l'energia e lo stato di benessere.



Kaschmir – Ihr hochwertiges Image verdankt die Faser ihrer Weichheit, ihrem seidigen Glanz und ihrer Geschmeidigkeit, die von keiner anderen Textilfaser übertroffen wird. Ihre Merkmale sind weich, geschmeidig, natürliche Thermoregulations-Eigenschaften, hautsympathisch und natural.



Cashmere – His reputation of high quality is due to the softness, shine and ductility that are unsurpassed by any other textile fiber. The main features are softness, elasticity, natural temperature control and skin compatibility.



Cachemire – L'image prestigieuse de cette fibre se base sur sa qualité de douceur, sa brillance soyeuse, ainsi que sa souplesse, qu'aucune autre fibre ne parvient à égaler. Cette fibre naturelle se caractérise également grâce à ses avantages de régulation thermique et sa forte tolérance pour les peaux sensible.



Cashmere – La sua fama di alta qualità è dovuta alla morbidezza, lucentezza e duttilità che sono insuperabili da qualsiasi altra fibra tessile. Le caratteristiche principali sono morbidezza, elasticità, termoregolazione naturale e dermocompatibilità.

CLIMAYARN®
Combines nature and high-performance

schoeller
the spinning group



Die Synthese aus der innovativen Hochleistungsfaser Polycolon und Wolffaser haben wir in einem Garn vereinigt: Climayarn. Es gleicht Temperaturschwankungen des Körpers wirkungsvoll aus. Die Thermoregulationsfunktion der Wolle wärmt bei Kälte, während der Polycolon-Anteil für einen schnellen Abtransport überschüssiger Feuchtigkeit sorgt. So wird bei hohen Temperaturen eine Hitzestaubildung weitgehend vermieden. Es bietet eine höhere Elastizität und trocknet wesentlich schneller als vergleichbare Baumwollware.



Schoeller Climayarn – Climayarn combines innovative, high-performance Polycolon fibre with natural wool. It regulates fluctuations in body temperature: wool's thermoregulatory effects conserve heat in cold weather, while Polycolon rapidly wicks excess moisture away from the body and largely prevents heat accumulation at high temperatures. It offers greater elasticity and dries much more quickly than comparable cotton products.



Climayarn – Associant les avantages de la fibre novatrice haute performance Polycolon à ceux de la laine vierge, la fibre mélangée Climayarn compense efficacement les fluctuations de la température corporelle. En effet, l'action thermorégulatrice de la laine réchauffe par temps froid, tandis que le Polycolon évacue rapidement l'humidité excédentaire tout en évitant considérablement l'accumulation thermique générée par des températures élevées. Climayarn se distingue par une élasticité accrue et sèche beaucoup plus vite que des produits en coton comparables.



La fibra Climayarn unisce la sintesi della innovativa fibra Polycolon a elevate prestazioni e della lana, consentendo di equilibrare in modo efficace le differenze di temperatura del corpo. La funzione termoregolatrice della lana fornisce calore in condizioni di freddo, mentre la fibra in Polycolon agevola un rapido drenaggio dell'umidità in eccesso. In tal modo è possibile evitare in pressoché qualsiasi circostanza un accumulo di calore alle elevate temperature. La fibra è dotata di una migliore elasticità rispetto agli assimilabili prodotti in cotone, asciugando inoltre in modo assai più veloce.

COOLMAX®
Active Performance



Coolmax® – Diese Hochleistungs-faser bietet höchsten Komfort zu jeder Jahreszeit. Sie ist weich, pflegeleicht und zeichnet sich durch hervorragende Feuchtigkeits-Transporteigenschaften und extrem kurze Trocknungszeiten aus. Aufgrund ihrer Konstruktion quillt die Faser nicht auf. Sie bleibt angenehm weich und hautsympatisch.



Coolmax® – This heavy-duty fibre provides optimal comfort for any time of the year. It is soft, requires minimum care and excels through its outstanding capacity to wick away moisture and its extremely short drying times. The fibre is designed in such a way that it does not swell up. It remains pleasantly soft and still feels good on the skin.





Coolmax® – Cette fibre de haute performance offre un confort maximal au porter en toute saison. Elle est douce, d'un entretien facile et se distingue par ses grandes qualités d'évacuation de l'humidité et un temps de séchage extrêmement réduit. Grâce à sa structure, cette fibre ne gonfle pas et reste agréablement douce au contact de la peau.





Coolmax® – Questa fibra ad alta resistenza offre un comfort ottimale in qualsiasi stagione. È morbida, richiede pochissima cura per conservare le sue caratteristiche ed è dotata di un'eccellente capacità di rimuovere il sudore e per di più asciuga in tempi brevissimi. La fibra è progettata in modo tale da non gonfiarsi. Essa conserva le sue caratteristiche di morbidezza ed è estremamente piacevole nel contatto diretto con la pelle.



 Crabyon-Fasern werden aus einem Chitosan-, Viskose- und Baumwollgemisch hergestellt. Gewonnen wird dieses Material aus dem äusseren Skelett, dem Chitinpanzer von Krabben. Dieser Panzer fällt bei der Verarbeitung als Restprodukt an und erfüllt bei der Herstellung von Crabyon einem nützlichen Zweck, anstatt in den Müll zu wandern. Das Aussergewöhnliche an diesem Material ist seine antibakterielle Wirkung, da damit das Wachstum von Bakterien abgebremst wird. Darüber hinaus ist Crabyon hervorragend feuchtigkeitsabsorbierend und für Allergiker geeignet.

 Crabyon – Crabyon fibres are made from a mixture of chitosan, viscose and cotton. Chitosan is derived from the exoskeletons of crabs and other crustaceans, which are made primarily of chitin. These shells are a residual product that can be put to good use in the manufacture of Crabyon, instead of being thrown away. The special thing about this material is its anti-bacterial properties – it actually inhibits the growth of bacteria. It is also very good at wicking away moisture and is suitable for people with allergies.

 Crabyon – Les fibres de Crabyon sont obtenues à partir d'un mélange de chitosane, de viscose et de coton. Le chitosane est extrait de l'endosquelette des crustacés, autrement dit de leurs carapaces, ces carapaces sont en fait des déchets qui, au lieu d'atterrir à la décharge, sont utilement valorisés par la fabrication de Crabyon. Capable de freiner la croissance bactérienne, ce matériau exerce donc une remarquable action antibactérienne. Anallergique, il maintient en outre les pieds au sec en absorbant l'humidité.

 La fibra composita del tessuto Crabyon è realizzata con una miscela di chitosano, di viscosa e di cotone. Il chitosano è una sostanza derivata dallo esoscheletro dei granchi, la cui corazza esterna è formata da chitina. Invece di essere trattate come scarti in quanto prodotto residuo dell'industria, queste corazze vengono efficacemente riutilizzate grazie alla produzione del tessuto Crabyon. La caratteristica peculiare di questa fibra è rappresentata dalla sua azione antibatterica, che consente di inibire la proliferazione dei batteri. Oltre a ciò, la fibra ha una elevata capacità di assorbimento dell'umidità e può essere normalmente utilizzata anche da soggetti allergici.



 Cupron ist eine Plattform-technologie entwickelt durch die Beschichtung und Imprägnierung von einer Baumwoll-Polymermischung mit Kupferoxid (CuO). Daraus resultieren Fasern, mit einem potentiell breiten Spektrum an antibakteriellen und antimykotischen Eigenschaften. Der Einsatz dieses Garnes in unseren Socken, mindert Geruchs- und Hautprobleme an Füßen. Studien haben eine Verbesserung oder ein Verschwinden der Hautrötung, der Fissuren, der Bläschenbildung, der Schuppen sowie des Brennens und Juckens belegt. Zuverlässig tötet es die meisten Pilze und auch geruchverursachende Bakterien ab, die bei langen Aktivitäten im Fussbereich entstehen.

 Cupron is a technological platform developed through the combination of a cotton/polymer mixture with copper-oxide (CuO). The result is a fibre with a large antibacterial and antifungal function. The use of such yarn in our socks, provides a reduction of odours and skin issues in the foot area. Studies have shown a reduction of skin redness, skin cracks, blister formation, scales and overall irritation. It also kills and reduces the number of fungus in the foot area, that are developing during long sport sessions.

 Cupron est une plate-forme technologique développée par la combinaison d'un mélange coton / polymère avec de l'oxyde de cuivre (CuO). Le résultat est une fibre avec une fonction antibactérienne et antifongique importante. L'utilisation de ce fil dans nos chaussettes permet de réduire les odeurs et les problèmes de peau dans la région des pieds. Des études ont montré une amélioration des rougeurs cutanées, des crevasses cutanées, de la formation de cloques, ainsi que la réduction d'une irritation générale. Celui-ci réduit le nombre de mycoses et de bactéries dans la région du pied, qui peuvent notamment se développer chez un athlète.

 Cupron è una tecnologia sviluppata rivestendo e impregnando una miscela cotone-polimero con ossido di rame (CuO). Questo si traduce in fibre aventi uno spettro potenzialmente ampio di proprietà antibatteriche e antimicotiche. L'uso di questo filato nei nostri calzini riduce i problemi di odore e delle pelli delicate nei piedi. Studi hanno dimostrato un miglioramento nei casi di arrossamento della pelle, screpolature, formazione di vesciche, desquamazione e prurito. Affidabile, uccide la maggior parte dei funghi e dei batteri che causano odore che si manifestano durante le lunghe attività nell'area del piede.

drirelease®

⊕ Dieses Garn, das aus einer einzigartigen Mischung aus synthetischen und natürlichen Fasern besteht, sorgt für einen beschleunigten Feuchtigkeitstransport. Drirelease verteilt nicht nur die Feuchtigkeit im Material und lässt sie langsam verdampfen, sondern transportiert auch (Transpirations-) Feuchtigkeit aktiv aus dem Kleidungsstück heraus. Von hier aus kann die Feuchtigkeit an die Luft abgegeben werden schneller als bei jedem anderen Material. So fühlen sich die Füße trockener und frischer an und bekämpfen Bakterienbildung und Schweißfüße erfolgreich.

⊕ Drirelease – This yarn, made from a unique mix of synthetic and natural fibres, ensures that moisture is wicked away very quickly. While other materials spread the moisture before slowly allowing it to evaporate, drirelease transports perspiration and other moisture to the outside of the textile. From there, it releases that moisture into the air around it more quickly than any other material. As a result, feet feel drier and fresher for longer, bacteria is inhibited, and sweaty feet are no longer an issue.

⊕ Drirelease – Composé d'un mélange unique en son genre de fibres naturelles et synthétiques, ce fil surdoué accélère l'évacuation de l'humidité. Loin de se contenter de disperser l'humidité dans le matériau et de la faire lentement évaporer, Drirelease fait passer la transpiration de l'autre côté du textile – donc à l'extérieur – où elle se dissipe plus rapidement dans l'atmosphère qu'avec aucun autre matériau. Les pieds restent ainsi davantage au sec et les chaussettes leur procurent une plus grande sensation de fraîcheur. Drirelease combat avec succès la formation de bactéries et les inconvénients liés aux pieds transpirants.

⊕ Questo tessuto, costituito da una speciale miscela di fibre sintetiche e naturali, è in grado di provvedere a una più rapida eliminazione dell'umidità. Anziché ripartire l'umidità tra le fibre del materiale per consentire una successiva e lenta evaporazione, i filati drirelease provvedono al drenaggio dell'umidità (altresi dovuta alla traspirazione) verso il lato esterno del tessuto, da dove essa viene rilasciata in aria in modo più veloce rispetto a qualsiasi altro tipo di fibra. Ciò consente di mantenere il piede più asciutto e fresco e di combattere in maniera efficace la proliferazione di batteri e una eccessiva sudorazione.

fresh

⊕ Highway Fresh hat eine antibakterielle, antistatische und geruchshemmende Funktion. Dank ihren therapeutischen Eigenschaften kommt Highway Fresh überall dort zu Einsatz, wo besondere Hautfreundlichkeit und Wohlbefinden gefragt sind.

⊕ Highway Fresh has an antibacterial, antistatic and odour inhibiting function. Thanks to its therapeutic properties, Highway Fresh is used wherever it is necessary to preserve the skin and the epidermis.

⊕ Highway Fresh a une fonction antibactérienne, antistatique et inhibitrice d'odeurs. Grâce à ses propriétés thérapeutiques, Highway Fresh est utilisé partout où il est nécessaire de préserver la peau et l'épiderme.

⊕ Highway Fresh ha una funzione antibatterica, antistatica e anti-odore. Grazie alle sue proprietà terapeutiche, Highway Fresh viene utilizzato ovunque sia richiesto lo speciale benessere della pelle.



⊕ Lycra® ist ein eingetragenes Warenzeichen für die Elastanfaser von INVISTA, unter der Lizenz von ADVANSA. Ihre hohe Elastizität garantiert optimale Passform und Komfort durch faltenfreien Sitz. Die dauerhafte Qualität von Lycra® ist besonders für hoch beanspruchte Sportsocken geeignet.

⊕ Lycra® is a registered trademark for the INVISTA elastane fibre, under the licence of ADVANSA. This material is highly elastic, ensuring maximum wearing comfort due to its close, wrinkle-free fit. The quality and durability of Lycra® make it ideal for use in high-performance sports socks.

⊕ Lycra® est une marque déposée INVISTA, sous la licence d'ADVANSA pour la fibre d'élasthanne. Sa grande élasticité se traduit par une forme parfaitement adaptée à l'anatomie et un grand confort grâce à un port sans plis. La qualité particulièrement résistante du Lycra® en fait une matière tout à fait adéquate pour les chaussettes de sport.

⊕ Lycra® è un marchio registrato per la fibra elastane di INVISTA, con licenza di ADVANSA. Si tratta di un materiale molto elastico, che garantisce il massimo comfort a chi lo indossa grazie alla calzata aderente, priva di grinze. Per la sua qualità e lunga durata, la Lycra® è la fibra ideale per calze da sport ad alte prestazioni.



Merinowolle stammt von den Merinoschafen, die ursprünglich in Spanien heimisch sind. Das Schaf wurden vor etwa 200 Jahren nach Australien exportiert, wo sich die Zuchtanstrengungen immer stärker auf die Verbesserung der Wolle konzentrierten. In Australien gibt es Merinoschafe, die sogar in Höhen bis zu 1800 m leben. Die Wolle schützt die Schafe sowohl gegen extreme Kälte wie auch grosse Hitze. Socken, in denen Merinowolle verarbeitet ist, bieten demnach im Winter wie auch im Sommer höchsten Tragekomfort. Darüber hinaus kratzt diese feinmaschige Wollsorte absolut nicht.

Merino wool - Merino wool is the wool from the Merino sheep, originating in Spain. Approximately 200 years ago, the sheep was exported to Australia, where breeding practices increasingly concentrated on the improvement of the wool. In Australia, Merino sheep live at altitudes of up to 1800 metres. The wool protects the sheep from both extreme cold and extremely hot conditions. That's why socks incorporating Merino wool ensure excellent comfort in both cold and hot conditions. And this fine-fibred wool doesn't itch at all.

La laine mérinos est celle des moutons mérinos originaires d'Espagne. Il y a environ 200 ans, le mouton a été introduit en Australie où les éleveurs n'ont cessé d'apporter tous leurs soins à l'amélioration de la laine. En Australie, on trouve même des moutons mérinos jusqu'à une altitude de 1800 mètres. La laine les protège aussi bien des températures glaciales extrêmes que des chaleurs torrides. Cela explique que les chaussettes comportant de la laine mérinos procurent hiver comme été un exceptionnel sentiment de bien-être. De plus, les fibres très fines de cette qualité de laine haut de gamme ne grattent absolument pas.

La lana merinos è la fibra che viene ricavata dal vello della omonima razza ovina, originaria della Spagna. Circa 200 anni fa la razza fu introdotta in Australia, paese nel quale gli allevatori si sono concentrati in modo sempre maggiore sulle tecniche di miglioramento della lana ottenuta. In Australia le pecore merinos vivono persino ad altezze che raggiungono i 1800 metri. La lana protegge gli animali dalle temperature estreme, siano esse fredde o calde. È per questo motivo che le calze in lana merinos garantiscono sempre un perfetto comfort, durante le stagioni più fredde come nei periodi di maggiore calura. La finezza delle fibre di questo tipo di lana non procura inoltre alcun fastidioso prurito durante l'indossamento.



Meryl Skinlife® ist eine bacteriostatische Faser, welche die natürliche Balance mit der Haut auch bei Aktivität hält. Die menschliche Haut hat ein natürliches Vorkommen von Bakterien. Eine höhere Anzahl als auch kein Vorkommen ergeben unterschiedliche Probleme (Allergien, Geruchsentwicklung, Krankheiten usw.). Meryl Skinlife® ist kein Bakterizid: Es reduziert den Bakterienlevel nicht tiefer als bei normaler Haut.

Meryl Skinlife® is bacteriostatic, a fibre which maintains a natural balance on the skin, regardless of activity level. The human skin normally has a bacteria presence. A high level of bacteria, as well as a complete absence, creates various problems (allergy, odour, illness etc.). Meryl Skinlife® is not a bactericide: it does not decrease the bacterial level lower than that normally present on the skin.

Meryl Skinlife® est une fibre bactériostatique préservant l'équilibre naturel de la peau même en cas d'activité. La peau humaine est naturellement peuplée de bactéries. Un nombre accru de bactéries, tout comme leur absence, peuvent causer différents problèmes (allergies, formation d'odeurs, maladies, etc.). Meryl Skinlife® n'est pas une fibre bactéricide : elle réduit le niveau de bactéries sans le faire passer en-dessous de celui d'une peau saine.

Meryl Skinlife® è una fibra batteriostatica che mantiene l'equilibrio naturale della pelle indipendentemente dal grado di attività di chi la indossa. Sulla nostra epidermide sono normalmente presenti dei batteri. Tanto un livello elevato di batteri quanto la loro completa assenza è causa di vari disturbi (allergie, odori, patologie ecc.). Meryl Skinlife® non agisce come battericida. Infatti, mantiene intatto il naturale equilibrio biologico della pelle.



Outlast®, das temperatur-regulierende PCM (Phase Change Material) Garn sorgt durch das zuverlässige Temperaturmanagement für kontinuierlich hohen Tragekomfort, welches grosse Temperaturschwankungen verhindert. Körperwärme wird aufgenommen wenn zuviel da ist und Wärme abgegeben wenn sie gebraucht wird. Dieser interaktive, zyklische Prozess hält die Temperatur in den Socken konstant auch dann, wenn das sportliche Betätigungsfeld oder die Temperaturen wechseln.

Outlast®, the temperature-regulating PCM (Phase Change Material) yarn, ensures constant comfort through its reliable temperature management, which prevents major fluctuations in temperature. When the conditions in the footwear are too hot, body heat is taken away, and warmth is provided when it is needed. This interactive, cyclical process maintains a constant temperature within the socks, even when there is a change in sports activities or temperature.

Outlast®, le fil thermorégulateur PCM (Phase Change Material), se charge de la gestion thermique pour éviter tout changement brutal de température et garantir un grand confort constant au porter. La chaleur corporelle excessive est emmagasinée et redistribuée en cas de besoin. Ce processus interactif et cyclique maintient une température constante dans la chaussette, même en cas de changement d'activité sportive ou de température.

Outlast®, il filato termoregolatore PCM (Phase Change Material) assicura sempre il comfort gestendo ed ottimizzando il calore corporeo, evitando così grandi sbalzi. Se i piedi si riscaldano troppo, il calore verrà eliminato mentre il filato produrrà calore quando è necessario. Questo processo interattivo, ciclico mantiene costante la temperatura all'interno delle calze, perfino in presenza di un cambiamento nell'attività sportiva o nella temperatura esterna.



Profilen® – Neue hoch technische Faser. Ist nicht brennbar, ist wasser- und schmutzabweisend und physiologisch unbedenklich. Mit Profilen® verstärkte Socken sind widerstandsfähig und schützen den Träger vor Blasen, da das Material keine Reibung verursacht. Ebenso wirkt diese Faser als optimaler Isolator.

Profilen® – A new high-tech fibre. It is non-flammable, repels dirt and water and is physiologically neutral. Socks reinforced with Profilen® are resistant and protect the wearer against blisters, as the material does not cause rubbing. This fibre also has excellent insulating properties.

Profilen® – Cette nouvelle fibre high tech. Elle est ininflammable, hydrofuge, peu salissante et neutre au niveau physiologique. Les chaussettes renforcées de Profilen® sont résistantes et protègent les pieds des ampoules, le matériau ne provoque aucune friction. Cette fibre est également un isolant idéal.

Profilen® – Una nuova fibra altamente tecnologica. Il materiale non è infiammabile, respinge lo sporco e l'acqua ed è fisiologicamente neutro. Le calze rinforzate con Profilen® sono resistenti e proteggono chi le indossa da vesciche perchè il materiale non provoca alcun sfregamento. Questa fibra ha inoltre eccellenti proprietà isolanti.



Dieses neue Garn ist eine Upcycling-Mischung aus postindustriellen Wollschneideabfällen, recycelten PET-Flaschen und Nylon 6.6, die für maximale Festigkeit und Weichheit ausgezeichnet wird.

This new yarn is an upcycled blend of post-industrial wool cutting scraps, recycled PET bottles, and Nylon 6.6, designed for maximum strength and softness.

Cette nouvelle laine est un mélange de chutes de laine industrielle, de bouteilles recyclées PET et de nylon 6.6 créé pour offrir un produit résistant et doux à la fois.

Questo nuovo filato è un prodotto ottenuto dal riciclaggio di una miscela di scarti di taglio della lana post-industriale, bottiglie in PET e nylon 6.6, ed è progettato per la massima resistenza e morbidezza.



 Resistex® Carbon ist ein Garn mit einzigartigen technischen Eigenschaften, die auf der Kombination textiler Fasern mit einem Endlosfilament aus Leitmaterial beruhen, das auf aktivem Kohlenstoff basiert. Durch die hohe Leitfähigkeit optimiert Resistex® Carbon den Feuchtigkeitstransport und begünstigt das Verdunsten von Schweiß. Unser Wohlbefinden ist umso besser, je weniger Feuchtigkeit auf der Haut verbleibt. Ebenfalls steigert es die muskuläre Leistungsfähigkeit.

 Resistex Carbon is a yarn by the unique technical characteristics, obtained by the union of textile fibers with a continuous filament of conductive material based on active carbon. The characteristics of high conductivity Resistex® Carbon also allow to improve the dispersion of moisture favoring sweat evaporation. The least moisture in contact with the skin, the greater is the sensation of wellbeing.

 Resistex® Carbon est un fil qui possède des propriétés techniques uniques reposant sur la combinaison de fibres textiles avec un filament sans fin composé de matière conductrice à base de carbone actif. La conductibilité élevée de Resistex® Carbon optimise aussi le transport d'humidité et favorise l'évaporation de la transpiration. Notre sensation de bien-être est d'autant plus forte que le niveau d'humidité sur la peau est faible. De plus, la performance musculaire est améliorée.

 Resistex® Carbon è un filato con caratteristiche tecniche uniche, fondate sulla combinazione di fibre tessili con un filamento continuo di materiale conduttivo, basato sul carbonio attivo. Grazie alla elevata conducibilità, Resistex® Carbon ottimizza anche il trasporto di umidità e favorisce l'evaporazione del sudore. Il nostro benessere è maggiore, se meno umidità rimane sulla pelle. Inoltre, aumenta la prestazione muscolare.



 SeaCell® ist die neue cellulosische Faser, in der Algen dauerhaft eingearbeitet sind. In den Algen sind wichtige Wirkstoffe wie Spurenelemente, Kohlenhydrate, Proteine und Vitamine enthalten. Durch den Hautkontakt (Temperatur / Feuchtigkeit) gibt Seacell® gezielt diese Wirkstoffe ab. Diese Faser hat nicht nur eine gesundheitsfördernde Wirkung, sie fühlt sich auf der Haut auch angenehm an. Das Produktionsverfahren von SeaCell® ist umweltschonend. Es werden keine Giftstoffe verwendet.

 SeaCell® is the new cellulosic fibre, which has algae incorporated permanently into it. Algae contains vital components such as trace elements, carbohydrates, proteins and vitamins. SeaCell® releases these components specifically upon contact with skin (temperature / humidity). This fibre does not only have health benefits, but also feels comforting to the skin. The method used to manufacture SeaCell® is environmentally friendly; no poisonous chemicals are used.

 SeaCell® est la nouvelle fibre cellulosique dans laquelle des algues sont intégrées de manière durable. Les algues contiennent des substances importantes telles que des oligoéléments, des hydrates de carbone, des protéines et des vitamines. En contact avec la peau (température / humidité), Seacell® dégage ces substances de manière ciblée. Cette fibre a non seulement un effet positif sur la santé, mais elle est aussi agréable sur la peau. Le processus de production de SeaCell® est non polluant, aucune substance toxique n'est utilisée.

 SeaCell® è la nuova fibra cellulosica, nella quale le alghe sono inserite permanentemente. Nelle alghe vi sono importanti sostanze come microelementi, carboidrati, proteine e vitamine. Con il contatto cutaneo (temperatura / umidità) Seacell® rilascia di proposito queste sostanze. Questa fibra non ha solamente un effetto benefico per la salute, è anche molto gradevole al tatto con la pelle. Il processo di produzione di SeaCell® è a basso impatto ambientale, e non vengono impiegate sostanze tossiche.



 Seide ist die stärkste Naturfaser. Welche sehr reiss- und scheuerfest und trotzdem elastisch ist. Ferner zeichnet Sie sich durch ihren Glanz und ihre hohe Festigkeit aus und wirkt isolierend gegen Kälte und Wärme. Zudem kann Sie bis zu einem Drittel ihres Eigengewichtes Feuchtigkeit aufnehmen.

 Silk is the strongest natural fiber. Is very tear and abrasion resistant, keeping a high flexibility. It also stands out for its shine, its high strength and its insulation propriety against cold and heat. In addition, it can absorb moisture up to one third of its own weight.

 La soie est une des fibres naturelles les plus solide. Résistante aux déchirures, ainsi qu'aux abrasions, elle reste cependant très douce et élastique. De plus, cette fibre offre des avantages non négligeables en terme de brillance et d'isolation thermique, agissant contre le froid et la chaleur. Finalement, la soie peut également absorber une humidité allant jusqu'à un tiers de son propre poids.

 La seta è la più forte fibra naturale. E' molto resistente allo strappo e all'abrasione se pur molto flessibile. Si distingue anche per la sua lucentezza, la sua alta resistenza e come isolante contro il freddo e il caldo. Questa fibra inoltre, può assorbire umidità fino a un terzo del proprio peso.



 Silver – Diese natürliche und hautverträgliche Faser ist antibakteriell, antistatisch und geruchshemmend. Dank ihren therapeutischen Eigenschaften kommt Silber überall dort zum Einsatz, wo besondere Hautfreundlichkeit und Wohlbefinden gefragt sind.

 Silver is a natural, skin-friendly fibre with anti-bacterial, anti-static and deodorising properties. Thanks to its inherent therapeutic properties, silver is used wherever skin-friendliness and well-being are required.

 Silver – Cette fibre naturelle et bien tolérée par la peau a une action antibactérienne, antistatique et freine le développement des odeurs. Grâce à ses propriétés thérapeutiques, la fibre d'argent s'utilise partout où une grande douceur pour la peau et du bien-être sont essentiels.

 Silver è una fibra naturale, benefica per la pelle con caratteristiche antibatteriche, antistatiche e deodoranti. Grazie alle sue proprietà terapeutiche, questa fibra setosa viene impiegata per tutte le applicazioni che favoriscono la salute della pelle e il benessere.



 Mit Smartcel Sensitive wird ein Garn bezeichnet, welches das Spurenelement Zink enthält. Dank eines hochwertigen Zinkoxids, dass in die Faser eingebunden ist, entwickelt Smartcel eine antibakterielle Wirkung sowie einen effektiven Schutz vor Umwelteinflüssen.

 Smartcel Sensitive is a yarn containing the trace element zinc. Thanks to the precious zinc oxides held within the fibre, Smartcel possesses antibacterial properties that provide effective protection against environmental elements.

 Smartcel Sensitive est le nom d'un fil qui contient du zinc, un oligoélément. Grâce à un oxyde de zinc de qualité qui est intégré dans la fibre, Smartcel développe un effet antibactérien ainsi qu'une protection efficace contre les impacts environnementaux.

 Con Smartcel Sensitive viene definito un filo, che contiene il microelemento zinco. Grazie ad un ossido di zinco di alta qualità, che è legato nella fibra, Smartcel sviluppa un effetto antibatterico ed anche un'effettiva protezione dagli influssi ambientali.



SwissModal zeichnet sich durch eine hohe Dimensionsstabilität sowohl im nassen als auch im trockenen Zustand aus und überzeugt durch einen angenehmen Griff. Zusätzlich hat SwissModal eine minimale Haarigkeit und verfügt über eine herausragende Anti-Pilling Eigenschaft.

SwissModal is characterised by a high dimensional stability when wet as well as when dry, and is extremely soft to the touch. In addition, SwissModal features minimal hairiness and outstanding anti-pilling properties.

SwissModal se distingue par une forte stabilité des dimensions autant à l'état mouillé qu'à l'état sec et séduit par son toucher agréable. De plus, SwissModal n'a qu'une pilosité minimale et dispose d'une excellente propriété anti-pilling.

SwissModal è caratterizzato da un'alta stabilità dimensionale sia nello stato bagnato, sia in quello asciutto e convince grazie alla sua gradevole presa. Inoltre SwissModal ha una bassa peluria e dispone di un'ottima caratteristica anti-pilling.



Die Polyamidfaser Tactel® sorgt mit ihrer sehr feinen Struktur für bequemen Tragkomfort und erhöht gleichzeitig die Haltbarkeit der Socke. Die Beimischung von Tactel® verlängert die Nutzungsdauer der Socke. Tactel® ist sehr atmungsaktiv und pflegeleicht.

Tactel® is a fine structure polyamide fibre which greatly increases the comfort and durability of socks. This material is also breathable and easy to care for.

La fibre de polyamide Tactel®, dotée d'une très fine structure, garantit un port très confortable tout en augmentant de façon substantielle la solidité de la chaussette. L'apport de Tactel® prolonge la vie utile de la chaussette. Tactel® facilite par ailleurs la respiration et est d'un entretien facile.

Tactel® è una fibra poliammidica a struttura fine che aumenta in maniera decisiva la comodità e la durata delle calze. Il materiale è traspirante e di facile mantenimento.



Tencel ist die erste auf Nanotechnologie basierte Cellulosefaser. Neue funktionelle Eigenschaften können aufgrund der Anordnung der Nanofibrillen in der Tencel Faser erzeugt werden. Die Nanofibrillen sind hydrophil und sorgen für eine optimale Feuchtaufnahme und Klimaeigenschaften. Tencel wird aus Holz aus nachhaltiger Forstwirtschaft gewonnen und ist 100% biologisch abbaubar. Für den umweltfreundlichen Herstellungsprozess wurde es vielfach ausgezeichnet.

Tencel is the first cellulose fibre based on nanotechnology. It is possible to produce new functional properties through the special arrangement of nanofibrils in the Tencel fibre. The nanofibrils are hydrophilic, thus ensuring optimum moisture absorption and climatic properties. Tencel is extracted from wood grown in sustainable forests and is 100% bio-degradable. It has been recognised with many awards for its environmentally-friendly manufacturing process.

Tencel est la première fibre de cellulose basée sur la nanotechnologie. La disposition des nano-fibrilles dans la fibre Tencel permet de générer de nouvelles propriétés fonctionnelles. Les nano-fibrilles hydrophiles assurent une absorption optimale de l'humidité et se distinguent par des propriétés climatisantes. Obtenue à partir de bois issu de l'exploitation forestière contrôlée, Tencel est 100 % biodégradable. Son processus de fabrication respectueux de l'environnement a été maintes fois récompensé.

Tencel è la prima fibra prodotta dalla cellulosa in cui è stata impiegata la nanotecnologia. Grazie all'inserimento e alla disposizione delle nanofibrille all'interno del filato Tencel, il tessuto offre caratteristiche funzionali del tutto nuove. La presenza delle nanofibrille conferisce proprietà idrofile al tessuto e garantisce un assorbimento dell'umidità e condizioni di comfort climatico ottimali. Per la produzione della fibra Tencel, biodegradabile al 100%, viene impiegato soltanto legno proveniente da silvicoltura rinnovabile. Il suo processo di fabbricazione è ecologico ed è stato insignito di numerosi riconoscimenti.



 Thermacool – Die Hohlfaser-technologie bietet maximale Wärme bei sehr geringem Gewicht. Die grössere Oberfläche erlaubt eine raschere Verdunstung durch schnelles Weggleiten der Feuchtigkeit von der Haut an die Oberfläche des Stoffes, wo es zur schnellen Verdunstung kommt.

 Thermacool – Hollow-core fibre technology provides the most warmth at the lightest weight. The larger surface area allows for faster evaporation by speeding moisture away from the skin to the surface of the fabric where it can evaporate more quickly.

 Thermacool – La technologie de fibres creuses offre une chaleur maximale pour un minimum de poids. La taille importante de surface favorise une évaporation plus rapide en accélérant le transport de l'humidité de la peau à la surface du tissu où elle peut s'évaporer plus rapidement.

 La tecnologia delle fibre a nucleo cavo Thermacool garantisce il miglior isolamento termico con il minimo peso. L'ampia superficie creata consente una traspirazione più rapida mediante l'evacuazione dell'umidità dalla pelle verso la superficie del tessuto, dove essa può evaporare velocemente.



 Aus einer ausgeklügelten Kombination aus Wool Blend-Fasern hergestelltes Garn besitzt hervorragende wärmende Eigenschaften. Darüber hinaus ist dieses Material wie kein anderes in der Lage, Feuchtigkeit aufzunehmen und abzuleiten. Deshalb bieten aus Wool Blend-Garnen gefertigte Socken höchsten Wärme- und Tragekomfort selbst unter extrem feuchten Bedingungen. Darüber hinaus ist das Material stabil und elastisch, eine Gewährleistung für ein angenehmes Tragegefühl und hohe Lebensdauer.

 Wool Blend – Yarn made of a clever composition of wool blend fibres has outstanding warming properties. It is also extremely good at wicking away moisture. Socks made from wool blend yarn are therefore always warm and comfortable, even under extremely damp conditions. The material is also strong and elastic, increasing comfort and wearability and extending the useable life.

 Wool Blend – Les fils obtenus à partir de mélanges très étudiés de différentes fibres de laine présentent d'excellentes qualités thermiques. En outre, ils n'ont pas leur pareil pour absorber et évacuer l'humidité. De ce fait, les chaussettes tricotées avec des mélanges de laines sont chaudes et confortables – même en milieux extrêmement humides. Autre atout majeur, ce matériau à toute épreuve est élastique : des qualités qui rendent le port des chaussettes plus agréable tout en prolongeant leur durée de vie.

 I filati costituiti da una varietà sapientemente combinata di fibre misto lana vantano eccezionali proprietà termiche. Un tessuto in misto lana dispone inoltre di straordinarie capacità assorbenti e traspiranti. Ciò consente alle calze prodotte con filati misto lana di mantenere il loro specifico tepore e comfort anche in condizioni di estrema umidità. Oltre a ciò, la fibra è dotata di ottime caratteristiche di resistenza ed elasticità, che le conferiscono elevata comodità nell'indossamento e maggiore durata.

Colour Codes

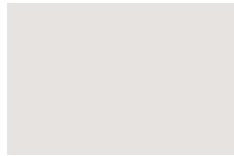

002 ecru



003 beige



008 weiss



009 schwarz



010 marine



011 bordeaux



014 violet



031 lemon



042 orange

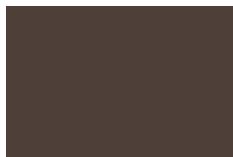

046 mocca



047 d'braun



058 mittelgrau



059 dunkelgrau



060 marengo



064 rost



070 marine dunkel



076 hellgrau



090 royalblau



114 vulkan



115 blue denim



123 schwarz denim



135 anthrazit



141 rosa



143 nature/natural



145 braun mele



157 red



161 ton



174 atlantic



181 khaki



186 bright blue



197 stein



213 marengo

COLOURS



221 tanne



228 limette



255 wüste



276 sandelholz



289 jeansmele



290 beigemele



304 blau



329 ocean



320 asphalt



366 grey



400 petrol



401 grün



404 mint



418 schnee



425 marine farbig gestreift



454 neo mint



455 lemon green



456 baby blue



461 bronze



463 ruby



492 old rose



493 grau



500 hunting



514 aqua



466 khaki/braun
mele gestreift



532 teer



538 teer/anthrazit



561 rot



556 blue



607 pink



623 raspberry



661 türkis

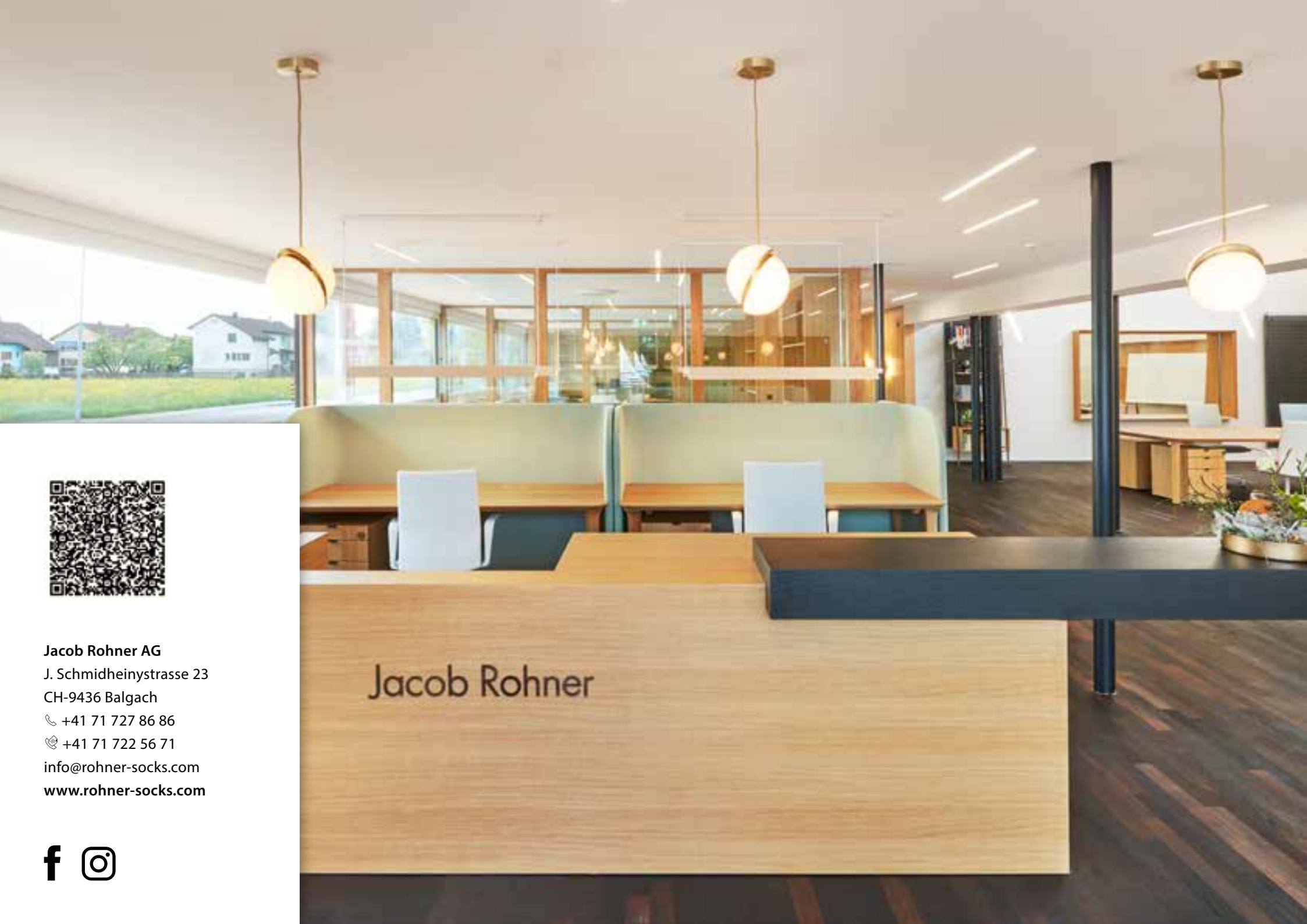

Jacob Rohner AG
J. Schmidheinystrasse 23
CH-9436 Balgach
☎ +41 71 727 86 86
✉ +41 71 722 56 71
info@rohner-socks.com
www.rohner-socks.com

