King 4002-0

20 Gallon Abrasive Blaster



SPECIFICATIONS

| | |
|-------------------------|-------------------------|
| Tank Size..... | 20 gallons |
| Hose Length..... | 8 ft. |
| Working Pressure..... | 60-125 psi |
| Air Consumption..... | 6-25 cfm |
| Overall Dimensions..... | 15.5" x 23" x 36.75" |
| Gross Weight..... | 53 lbs |

WARNING:

The warnings, cautions and instructions discussed in this instruction manual cannot cover all possible conditions or situations that could occur. It must be understood by the operator that common sense and caution are factors which cannot be built into this product, but must be supplied by the operator.

TABLE OF CONTENTS

| Description | Page # |
|-------------------------|---------------|
| Safety rules..... | 1 |
| Assembly..... | 2 |
| Operation..... | 2-3 |
| Maintenance..... | 3 |
| Abrasive Selection..... | 3-4 |
| Warranty..... | 4 |
| Pars List and Diagrams | 5 |

READ THE INSTRUCTIONS BEFORE OPERATING SAVE INSTRUCTION BOOK

Thank you for purchasing your King 4002-0 20 Gallon Abrasive Blaster. Before attempting to operate your new blaster please read these instructions for the safety warnings, precautions, assembly, operation, maintenance procedures, parts list and diagrams. Keep your invoice with these instructions. Write the invoice number on the inside of front cover. Keep the instructions and invoice in a safe, dry place for future reference.

READ ALL SAFETY RULES

- 1.** Do not use any sand or silica based abrasives with this tool. Silica based abrasives have been linked to severe respiratory disease. Always use OSHA recommended abrasives.
- 2.** Know your tool. Read this manual carefully. Learn the tool's applications and limitations, as well as potential hazards specific to it.
- 3.** Do not expose tool to moisture. Don't use this tool in damp or wet locations. Keep out of rain.
- 4.** Keep work area clean and well lit. Cluttered or dark work areas invite accidents.
- 5.** Keep children away. All children should be kept away from the work area. Never let a child handle a tool without strict adult supervision.
- 6.** Do not operate this tool if under the influence of alcohol or drugs. Read warning labels on prescriptions to determine if your judgment or reflexes are impaired while taking drugs. If there is any doubt, do not attempt to operate.
- 7.** Use safety equipment. Eye protection should be worn at all times when operating this tool. Use ANSI approved safety glasses. Everyday eyeglasses are NOT safety glasses. Dust mask, non-skid safety shoes, hard hat, or hearing protection should be used in appropriate conditions.
- 8.** Wear proper apparel. Loose clothing, gloves, neckties, rings, bracelets, or other jewelry may present a potential hazard when operating this tool. Please keep all apparel clear of the tool.
- 9.** Don't overreach. Keep proper footing and balance at all times when operating this product
- 10.** Always disconnect the tool from air supply and release pressure from the tank before making any adjustments, storing, servicing or changing accessories. Such preventative safety measures reduce the risk of starting the tool accidentally.
- 11.** Use clamps or other practical means to secure and support the work piece to a stable platform. Holding the work by hand or against your body may lead to a loss of control.
- 12.** Do not force tool. Use the correct tool for your application. The correct tool will do the job better and safer at the rate for which it was designed.
- 13.** Check for damage. Check your tool regularly. If part of the tool is damaged it should be carefully inspected to make sure that it can perform its intended function correctly. If in

doubt, the part should be repaired. Refer all servicing to a qualified technician. Consult your dealer for advice.

- 14.** Keep away from flammables. Do not attempt to operate this tool near flammable materials or combustibles. Failure to comply may cause serious injury or death.
- 15.** Always check to make sure that the trigger is not on before connection blaster to air supply. Tool may cause damage to property or person if plugged in while on.
- 16.** Store idle tools out of the reach of children and untrained persons. Tools may be dangerous in the hands of untrained users.
- 17.** Drain water trap periodically during use. Do not allow moisture to fill more than $\frac{1}{2}$ the water trap bowl. Do not leave water standing in water trap when done with work.
- 18.** Do not allow abrasive blaster to sit pressurized while unattended or not in use
- 19.** Make sure all equipment is rated to the appropriate capacity. Make sure regulator is set a no higher than 125 psi.
- 20.** Periodically check the abrasive medium delivery equipment. Valves, hoses and nozzles that carry the abrasive medium after it leaves the pressure tank are subjected to the abrasive blasting action so will wear out more quickly than other components.
- 21.** Release the air pressure in the tank before opening. See "Releasing Pressure from the Tank" section. Make sure pressure gauge reads "0" before opening the tank. Do not attempt any maintenance on the abrasive blaster until the pressure gauge reads "0" and it has been disconnected from air supply.
- 22.** Maintain correct air pressure whenever working. Do not allow pressure to exceed 125 psi. If the safety valve does not release excess air pressure, stop all work and release pressure from the tank. (see "Releasing Pressure from the Tank" section).

AIR/ABRASIVE SUPPLY REQUIREMENTS

| Hose ID | Hose L | Nozzle ID | Compressor HP | CFM@ 125 psi | Abrasive Use/Hr |
|---------|--------|-----------|---------------|--------------|-----------------|
| 3/8 | 50 ft | 2 | 2 | 6 | 30 lbs. |
| 3/8 | 25 ft | 2.5 | 4 | 12 | 80 lbs. |
| 1/2 | 50 ft | 3 | 7 | 20 | 120 lbs. |
| 1-1/2 | 15 ft | 3.5 | 10 | 25 | 150 lbs. |

ASSEMBLY INSTRUCTIONS

Note: Use Teflon pipe tape on all threaded joints. Make sure all joints are securely tightened.

Abrasive Safety Trigger Assembly (Figure 1)

1. Slide the two Hose Clamps (24), over each end of the Abrasive Hose (25).
2. Press one end of the hose, over the nipple on the Abrasive Outlet Pipe (23), and the other end over the Abrasive Safety Trigger Hose Adapter (49).
3. Both hose ends should be firmly seated on the nipples. Slide the hose clamps along the hose to each nipple and tighten the clamps very firmly. They have to resist the force of 60 to 125 PSI.

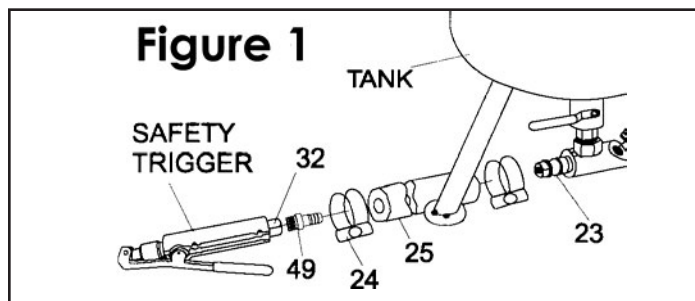

Handlebars, Wheels and Foot Assembly (Figure 2)

1. Lay the Abrasive Blast Tank on a flat level surface (such as a workbench or table top), with the handlebar mounting brackets facing up.
2. Align the 4 holes in the Handlebar (06) with the four holes in the handlebar mounting brackets. Note: Keep the curved end of the handle facing upward.
3. Place a Washer (10) onto each of the four handlebar mounting Screws (08) and insert them through each of the four holes.

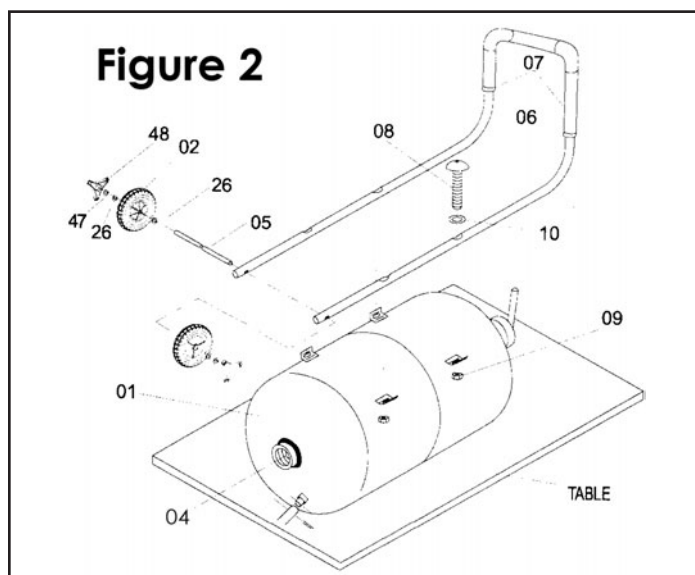

4. Place a nut (09) onto the end of each screw and firmly tighten with a wrench.
5. Locate the Wheel Axle (05) and slide it through the axel holes located at the bottom of the handlebar.
6. Slide a wheel Washer (26) onto each end of the wheel axle.
7. Slide a Wheel (02) onto each end of the wheel axle.
8. Slide a wheel Washer (26) onto each end of the wheel axle.
9. Using snap ring pliers, install a Snap Ring (47) onto each end of the wheel axle. Note: Wheel axle has a groove cut into it – snap ring should rest in this groove so it will not slide off the wheel axle.
10. Firmly snap Wheel Lids (48) into place on wheels.
11. Roll Abrasive Blast Tank over so that handle is now facing down.
12. Align the holes of the Front Foot (04) with the holes in the foot mount on the front side of the Blast Tank.
13. Insert a Cotter Pin (03) through the holes and bend it so the Front Foot cannot slide off the foot mount.

OPERATION

Warning: Always wear your hood, dust masks and heavy duty canvas gloves when operating the abrasive blaster.

Warning: Before operating your abrasive blaster, inspect each connection, double checking to make sure that all are tight and properly sealed.

WARNING: THIS MACHINE IS NOT INTENDED FOR USE WITH SILICA BASED ABRASIVES. SILICA BASED ABRASIVES HAVE BEEN LINKED TO SEVERE RESPIRATORY DISEASE. ALWAYS USE SILICA SUBSTITUTES WHEN ABRASIVE BLASTING!

Loading Abrasive

1. Check to make sure the abrasive is dry and clean so that it does not clog the unit.
2. Close the brass Air Supply Valve (19) by turning it to the vertical position.
3. To release the pressure from the Tank, press Safety Trigger until air stops.
4. Make sure the Pressure Gauge (16) reads "0".

5. Remove the Filler Cap (13).
6. Using the Funnel (27), pour the selected abrasive media into the tank (1). Do not fill the tank more than $\frac{2}{3}$ full. If humidity in your region is 90% or more, only fill the tank half full and check the water trap (18) more frequently.
7. Close the Filler Cap securely, assuring o-ring is in place.

Note: Place your air compressor in another room to prevent damage to it.

To Start Abrasive Blasting

Note: Start with all valves in the closed position. Following the instructions below will help prevent the formation of clogs in the abrasive hose, outlet manifold and the safety trigger.

1. Connect air compressor to the inlet Connector (20).
2. Start compressor and open Air Supply Valve (19).
3. Open Throttling Valve (19A).
4. Check for leaks at the Filler Cap and along all hoses and fittings as the system pressurizes. If leaks are observed, release the pressure from the tank and repair immediately.
5. Point Safety Trigger in a safe direction away from people, pets or anything around you that may be damaged by direct or indirect abrasive spray.
6. Press and hold Safety Trigger until air is flowing through the trigger.
7. With the Safety Trigger open, slowly open the Abrasive Control Valve (19B) until abrasive material begins to flow out of the Safety Trigger
8. Adjust the Abrasive Control Valve (19B) until the desired amount of abrasive material is flowing through the Safety Trigger.
9. Begin blasting.

To Stop Blasting

1. While continuing to press and hold the Safety Trigger, turn the Abrasive Control Valve (19B) to the closed position (this is to prevent any clogging.)
2. When you notice only air (no abrasive) is coming out of the Safety Trigger, you can stop the air flow by releasing the trigger/ By doing this you are insuring a clean and clog-free manifold, hose and safety trigger.

Releasing Pressure from the Tank

1. When finished blasting, point Safety Trigger in a safe direction away from people, pets or anything around you that may be damaged by direct or indirect abrasive spray.
2. Press and hold the Safety trigger to expel any remaining abrasive material from the Abrasive Hose (25).
3. Close the Abrasive Control Valve (19B).
4. Release pressure on the Safety Trigger.
5. Close the Throttling Valve (19A) and the Air Supply Valve (19).
6. Disconnect air supply hose from abrasive blaster.
7. Press the Safety Trigger until air stops flowing and Pressure Gauge (16) reads "0".

MAINTENANCE

1. Keep your abrasive blaster clean, and protect it from damage.
2. Release pressure from the tank after each use.
3. When initially pressurizing, check for leaks at the tank top and at all hoses and fittings. Leaking joints may be repaired by replacing worn or damaged parts and Teflon tape at joints.
4. Check for worn abrasive hose and fittings. The Abrasive Control Valve, manifold and all parts after the abrasive is ejected from the tank are subject to rapid wear due to the flow of abrasive. Watch especially for leaks, blistering, bulging or thinness of the hose. Replace any parts which appear worn

ABRASIVE SELECTION

The kind of abrasive you choose will greatly influence the amount of time needed to clean a given surface area. Abrasive materials include garnet, glass beads and others. **For best results, use 800 grit abrasive or finer. Do not exceed 80 grit media size.**

Abrasive Media Quick Reference Guide

Red Garnet

Hardness: 8

Red Garnet is good for general metal usage. Ideal for general rust, paint and scale removal from metal parts.

Glass Bead

Hardness: 6

Perfect for light deburring or applying satin-like finishes on parts. Round shape of glass bead keeps it from cutting into work surfaces; instead the surface is pounded or "peened."

Make sure that the abrasive you use is thoroughly dry. Damp abrasive you use is cause clogging of your abrasive blaster.

While you may cause reuse abrasive, remember that abrasive becomes smoother and rounder, thus reducing abrasive effectiveness.

Reusing abrasive may also cause clogging due to debris contained in the mixture from prior use.

Abrasive Flow Adjustment

Choose a larger nozzle for a broader spray pattern. Choose a smaller nozzle for more focused abrasive blasting.

Adjust air pressure with the Brass Throttling Valve (19A). Adjust abrasive flow with Abrasive Control Valve (19B).

Watch for abrasive clogging. Release pressure from the tank if necessary and replace the abrasive with drier or cleaner abrasive.

Safety and Health Considerations

WARNING: THIS MACHINE IS NOT INTENDED FOR USE WITH SILICA BASED ABRASIVES. SILICA BASED ABRASIVES HAVE BEEN LINKED TO SEVERE RESPIRATORY DISEASE. ALWAYS USE SILICA SUBSTITUTES (SUCH AS CLARKE AB2531-GLASS BEAD OR AB2532-RED GARNET) WHEN ABRASIVE BLASTING!

Before opening tank make sure that it is not pressurized. Be sure that the gauge reads "0". If the gauge does not read "0", release pressure from the tank (see "Releasing Pressure from the Tank" (see "Releasing Pressure from the Tank" section).

Disconnect the compressor before opening tank.

Protect yourself and those around you from "over-spray". Remember that your portable abrasive blaster is shooting a powerful spray or abrasive material. Do not point it at yourself or anyone around you.

Wear protective clothing including hood (28) safety eye covering, and heavy gloves when using this abrasive blaster.

Wear a filter or mask over your mouth when using this tool. You will create a cloud of abrasive material and debris which is dangerous to inhale. Remove, cover or protect anything around you that might be damaged from direct or indirect contact with abrasive spray or particles. Nothing subject to contamination damage or with a fine surface should be near your abrasive blaster.

Caution

Pay particular attention to the Abrasive Hose (25), the Abrasive Control Valve (19B), and the Nozzles (35) as they will wear out much more quickly than the other pieces.

The Abrasive Hose needs to be replaced immediately if its side walls develop leaks or show blisters in the surface. Do not use if any of these problems are present.

KING ONE YEAR WARRANTY

This product is warranted against defect in material and manufacturing workmanship for a period of one year. Consumable parts such as blades, nozzle tips, motor brushes, bulbs, etc... are not covered under the warranty. We have strict quality control standards and we are proud of the quality of our products. However, sometimes a product may get shipped that does not perform properly in the first 30 days you can take it back to the retail store where you bought it for a refund or replacement. After 30 days it must be shipped to King at the following address. Before you return the product call for an authorization number. If all you need is a part that can be shipped to you at no charge under warranty. If you are making a return or ordering a replacement part need to have proof of the date of purchase will be required.

KING TOOLS & EQUIPMENT

CUSTOMER SERVICE

800-954-5464 or 909-930-6588

SHIP TO:

KING TOOLS & EQUIPMENT

1255 ACACIA ST.

ONTARIO, CA 91761

PRODUCTS RETURNED WILL BE REPAIRED NO CHARGE IF THEY ARE UNDER WARRANTY AND HAVE NOT BEEN MODIFIED OR ABUSED. ONCE REPAIRED THEY WILL BE RETURNED POSTAGE PAID. IF THERE IS A CHARGE FOR ANYTHING YOU WILL BE CONTACTED WITH AN ESTIMATE. REPAIRS MUST BE PAID IN ADVANCE BY CREDIT CARD OR CHECK.

PART LIST & DIAGRAM

| Item# | Descriptions | Qty |
|----------|-----------------------------|-----|
| 4002-01 | Tank | 1 |
| 4002-02 | Wheels | 2 |
| 4002-03 | Cotter Pins | 1 |
| 4002-04 | Front Foot | 1 |
| 4002-05 | Wheel Axle | 1 |
| 4002-06 | Handlebar | 1 |
| 4002-07 | Handle Grip | 1 |
| 4002-08 | Screw | 4 |
| 4002-09 | Hex Nut | 4 |
| 4002-10 | Washer | 4 |
| 4002-11 | Safety Valve | 1 |
| 4002-12 | O-Ring | 1 |
| 4002-13 | Filler Cap | 1 |
| 4002-14 | Joint Pipe | 1 |
| 4002-15 | Intake Mainfold | 1 |
| 4002-16 | Pressure Gauge | 1 |
| 4002-17 | Nipple Connector | 4 |
| 4002-18 | Water Trap Filter | 1 |
| 4002-19 | Brass Air Supply Valve 3/8" | 1 |
| 4002-19A | Brass Throttling Valve 3/8" | 1 |
| 4002-19B | Abrasive Control Valve 3/8" | 1 |
| 4002-20 | Inlet Connector | 1 |
| 4002-21 | Nipple Connector | 1 |
| 4002-22 | Air Hose | 1 |
| 4002-23 | Abrasive Outlet Pipe | 1 |
| 4002-24 | Hose Clamp | 1 |
| 4002-25 | Abrasive Hose | 1 |
| 4002-26 | Wheel Washer | 1 |
| 4002-27 | Funnel | 1 |
| 4002-28 | Hood | 1 |
| 4002-29 | Body Upper | 1 |
| 4002-30 | Body Lower | 1 |
| 4002-31 | Metalyal Pipe | 1 |
| 4002-32 | IntakeConnector | 1 |
| 4002-33 | Adaptor | 1 |
| 4002-34 | Gasket | 1 |
| 4002-35 | Ceramic Nozzle | 4 |
| 4002-36 | Rubber Adaptor | 4 |
| 4002-37 | Nozzle Cap Nut | 1 |
| 4002-38 | Screw ST 4.2 X16 | 4 |
| 4002-39 | Screw ST 4.2 X16 | 2 |
| 4002-40 | On/Off Control Lever | 1 |
| 4002-41 | Spring Pin | 1 |
| 4002-42 | Rubber Pad | 1 |
| 4002-43 | Screw M3 X 25 | 1 |
| 4002-44 | Hard Alloy Pad | 1 |
| 4002-45 | Nut M3 | 1 |
| 4002-46 | Snap Ring | 2 |
| 4002-47 | Ring | 2 |
| 4002-48 | Wheel Lids | 2 |
| 4002-49 | Hose Adaptor | 1 |

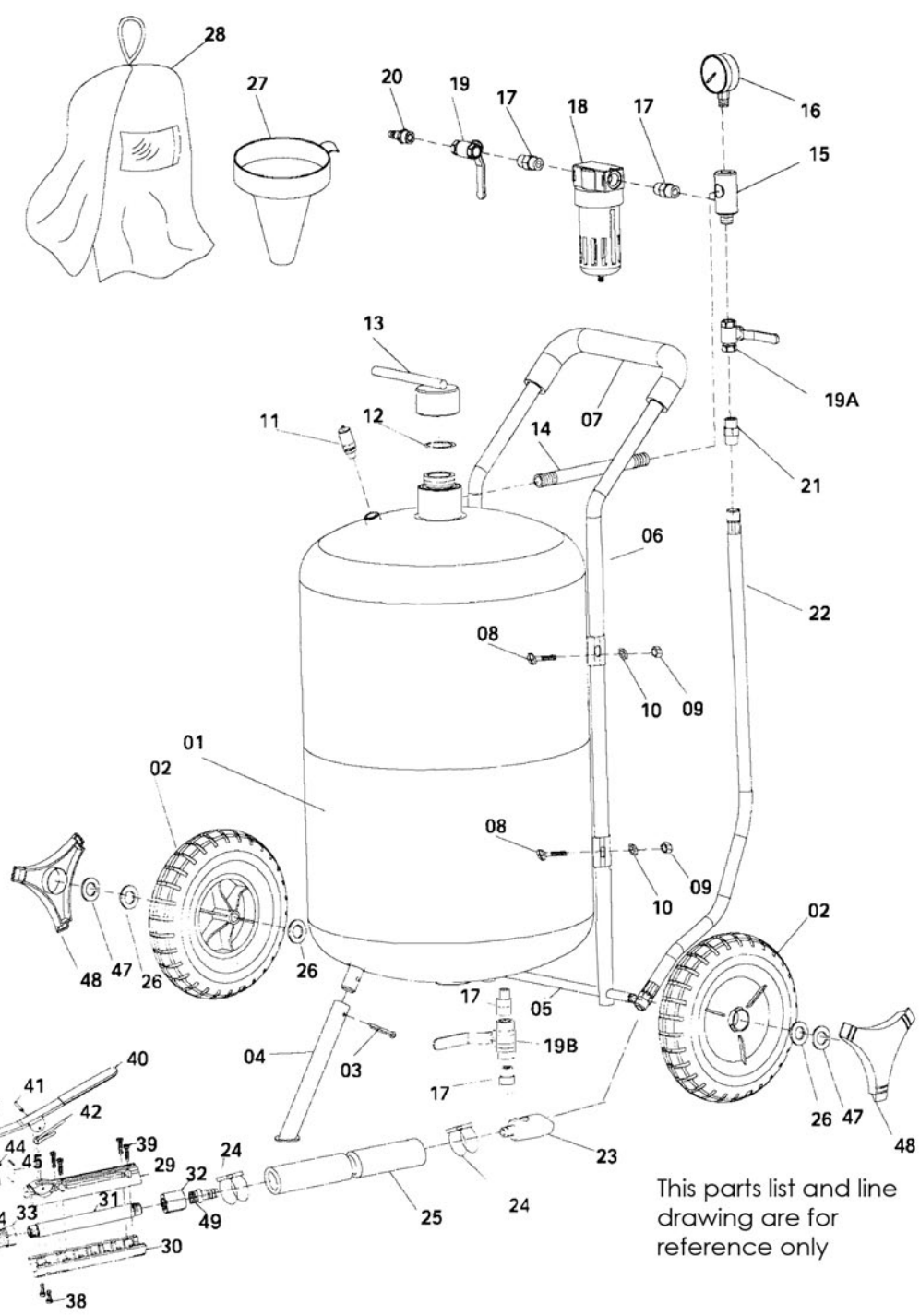

This parts list and line drawing are for reference only