

# **2-STAGE TELESCOPE TRANSMISSION JACK**

**CAPACITY: 0.5 TON  
INSTRUCTION MANUAL**



# WARNING

1. MAINTAIN THE JACK IN GOOD CONDITION. USE A QUALIFIED PERSON TO LUBRICATE AND MAINTAIN THE JACK. KEEP IT CLEAN FOR BEST AND SAFEST PERFORMANCE.
2. THE USE OF THIS JACK IS LIMITED TO THE REMOVAL, INSTALLATION AND TRANSPORTATION IN THE LOWEST POSITION, OF GEARBOXES AND DIFFERENTIALS. IT MAY BE USED WITH APPROPRIATE ADAPTORS MANUFACTURED ESPECIALLY FOR THIS JACK TO HANDLE OTHER COMPONENTS, SUCH AS REAR AXLE UNITS AND TRANSFER CASES WHICH ARE WITHIN THE WEIGHT LIMITATIONS SPECIFIED.
3. BE SURE THAT THE VEHICLE IS APPROPRIATELY SUPPORTED BEFORE STARTING REPAIRS.
4. THE MAXIMUM LOAD IS 0.5TON. DO NOT EXCEED THIS RATED CAPACITY.
5. THIS JACK IS DESIGNED FOR USE ONLY ON HARD LEVEL SURFACES WHICH ARE CAPABLE OF SUSTAINING THE LOAD. USE ON SURFACES OTHER THAN HARD LEVEL SURFACES CAN RESULT IN JACK INSTABILITY AND POSSIBLE LOSS OF LOAD.
6. FAILURE TO HEED THESE WARNINGS MAY RESULT IN LOSS OF LOAD, DAMAGE TO JACK, AND/OR PERSONAL INJURY OR PROPERTY DAMAGE.

## Maintenance

The hydraulic system is a closed system and normally needs no maintenance.

The mechanical parts of the pedal must be frequently lubricated using high-quality lube oil.

When the transmission jack is in its lowest position, the hydraulic oil level should not come up over the filling plug.

The hydraulic system is filled with enough oil if the lifting saddle can be pumped up to the top position.

When the jack is not in use, it must be stowed in the lowest position to minimise ram and piston corrosion.

# EXPLODED DRAWING

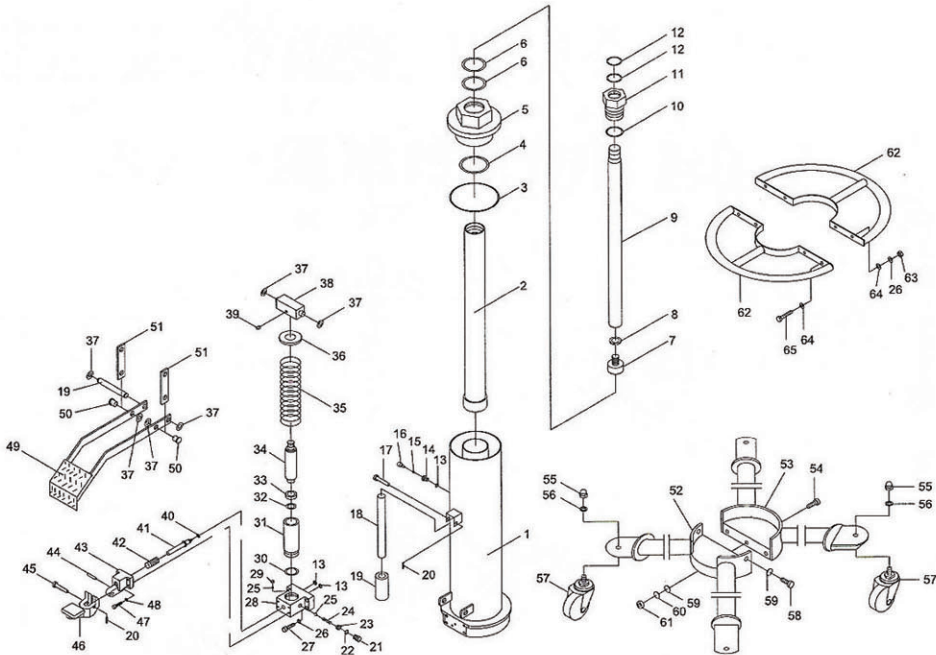

| NO | DESCRIPTION    | Q'TY | NO | DESCRIPTION     | Q'TY | NO | DESCRIPTION         | Q'TY |
|----|----------------|------|----|-----------------|------|----|---------------------|------|
| 1  | CYLINDER       | 1    | 22 | O-RING          | 1    | 43 | RELEASE VALVE BASE  | 1    |
| 2  | RAM 1          | 1    | 23 | SCREW           | 1    | 44 | PIN                 | 1    |
| 3  | O-RING         | 1    | 24 | SPRING          | 1    | 45 | PIN                 | 1    |
| 4  | O-RING         | 1    | 25 | BALL            | 2    | 46 | RELEASE VALVE PEDAL | 1    |
| 5  | TOP NUT 1      | 1    | 26 | LOCK WASHER     | 8    | 47 | SCREW M6*35         | 4    |
| 6  | O-RING         | 2    | 27 | SCREW M8*35     | 4    | 48 | LOCK WASHER         | 4    |
| 7  | RETAINER RAM   | 1    | 28 | PUMP BASE       | 1    | 49 | LIFTING PEDAL       | 1    |
| 8  | LOCK WASHER    | 1    | 29 | SCREW           | 1    | 50 | PIN                 | 2    |
| 9  | RAM 2          | 1    | 30 | NYLON RING      | 1    | 51 | LINK                | 2    |
| 10 | O-RING         | 1    | 31 | PUMP CYLINDER   | 1    | 52 | LEG ASS'Y           | 1    |
| 11 | TOP NUT 2      | 1    | 32 | RETAINING RING  | 1    | 53 | LEG ASS'Y           | 1    |
| 12 | O-RING         | 2    | 33 | SEALING RING    | 1    | 54 | BOLT                | 3    |
| 13 | O-RING         | 3    | 34 | PUMP PISTON     | 1    | 55 | NUT                 | 4    |
| 14 | NUT            | 1    | 35 | SPRING          | 1    | 56 | LOCK WASHER         | 4    |
| 15 | RING           | 1    | 36 | SPRING RETAINER | 1    | 57 | CASTER ASS'Y        | 4    |
| 16 | BREATHER VALVE | 1    | 37 | RETAINER RING   | 6    | 58 | BOLT                | 3    |
| 17 | PIN            | 2    | 38 | CONNECTING ROD  | 1    | 59 | WASHER              | 3    |
| 18 | HANDLE         | 1    | 39 | SET SCREW       | 1    | 60 | LOCK WASHER         | 3    |
| 19 | HANDLE SLEEVE  | 1    | 40 | O-RING          | 1    | 61 | NUT                 | 3    |
| 20 | COTTER PIN     | 2    | 41 | RELEASE VALVE   | 1    |    |                     |      |
| 21 | SCREW          | 1    | 42 | SPRING          | 1    |    |                     |      |

# EXPLODED DRAWING

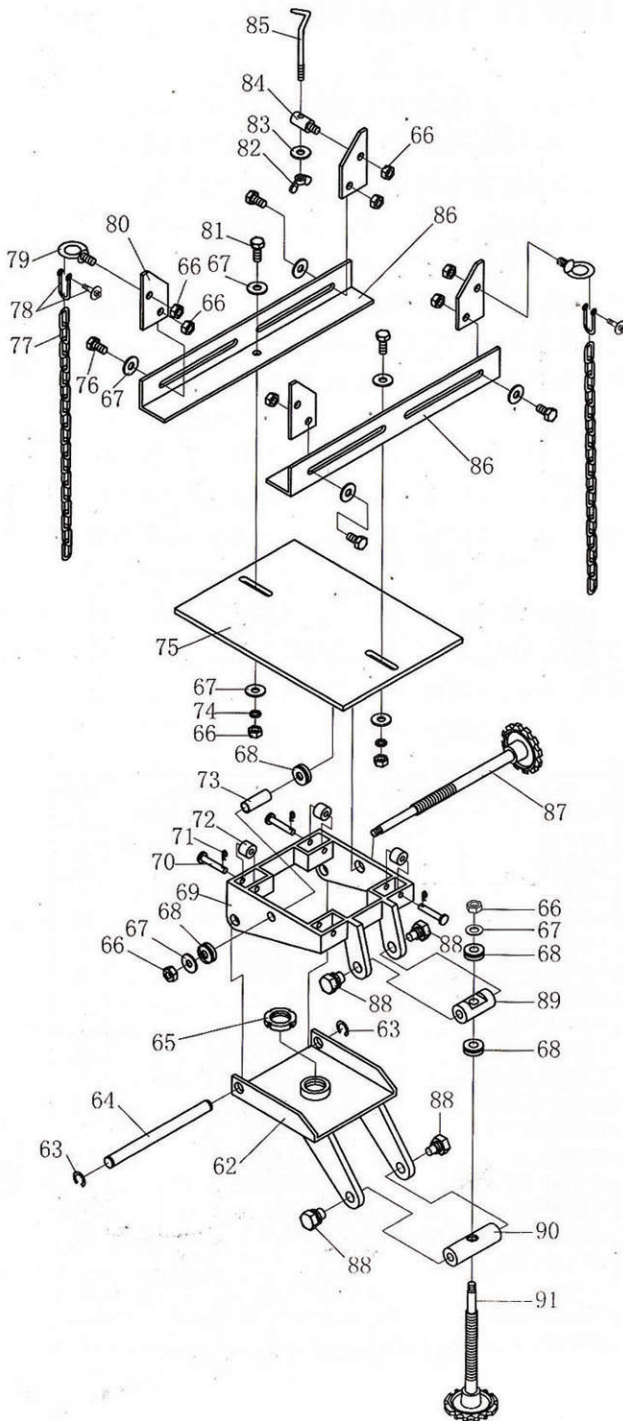

| NO: | DESCRIPTION      | Q' TY |
|-----|------------------|-------|
| 62  | BOTTOM PLATE     | 1     |
| 63  | RETAINING RING16 | 2     |
| 64  | CONNECTING ROD   | 1     |
| 65  | SCREW            | 1     |
| 66  | SCREW            | 12    |
| 67  | WASHER           | 10    |
| 68  | BEARING          | 4     |
| 69  | TILTING SADDLE   | 1     |
| 70  | PIN              | 4     |
| 71  | PIN              | 4     |
| 72  | BUSH             | 4     |
| 73  | BUSH             | 1     |
| 74  | LOCK WASHER      | 2     |
| 75  | SADDLE KIT       | 1     |
| 76  | SCREW            | 4     |
| 77  | CHAIN            | 2     |
| 78  | SHACKLE          | 2     |
| 79  | SCREW            | 2     |
| 80  | PLATE            | 4     |
| 81  | SCREW            | 2     |
| 82  | FLY NUT          | 2     |
| 83  | WASHER           | 2     |
| 84  | BAR              | 2     |
| 85  | SCREW            | 2     |
| 86  | ANGLE            | 2     |
| 87  | AJUSTABLE SCREW  | 1     |
| 88  | SCREW            | 4     |
| 89  | STRATIONARY ROD  | 1     |
| 90  | STRATIONARY ROD  | 1     |
| 91  | AJUSTABLE SCREW  | 1     |