

Equipment Defender

Trimmer Rack Instructions

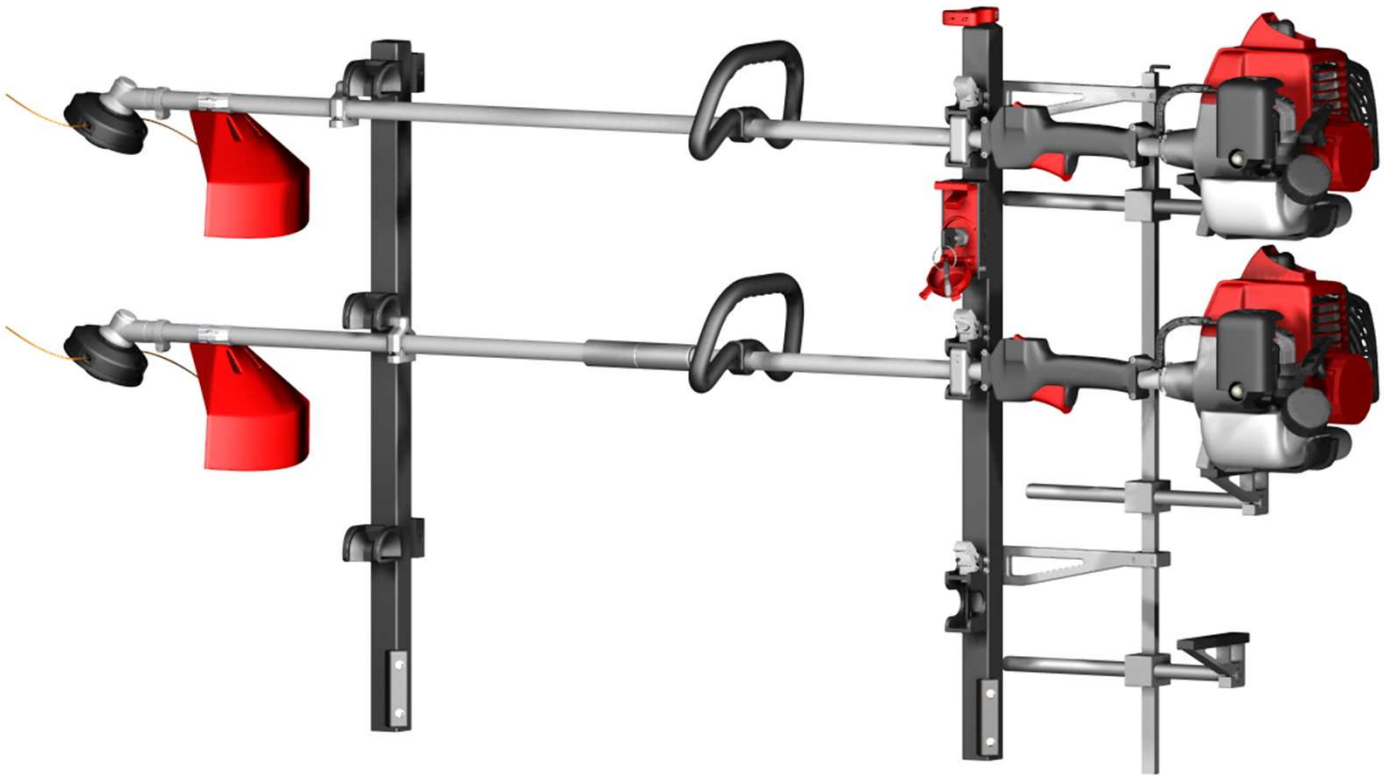

Equipmentdefender.com

1-800-735-3029

Sales@equipmentdefender.com

Mounting on Open Trailers

Step 1: Drill the deck boards for the mounting posts. Hold the posts in position and drill $3/8$ " holes through the deck boards, approximately 36 inches apart center to center, this dimension can be increased or decreased to suit your needs. Keep in mind, if you are setting up multiple trailers this dimension should be the same on all so your equipment can be interchanged. Use the long carriage bolts to secure the posts. **Note: the farther apart they are the better your equipment will be supported.**

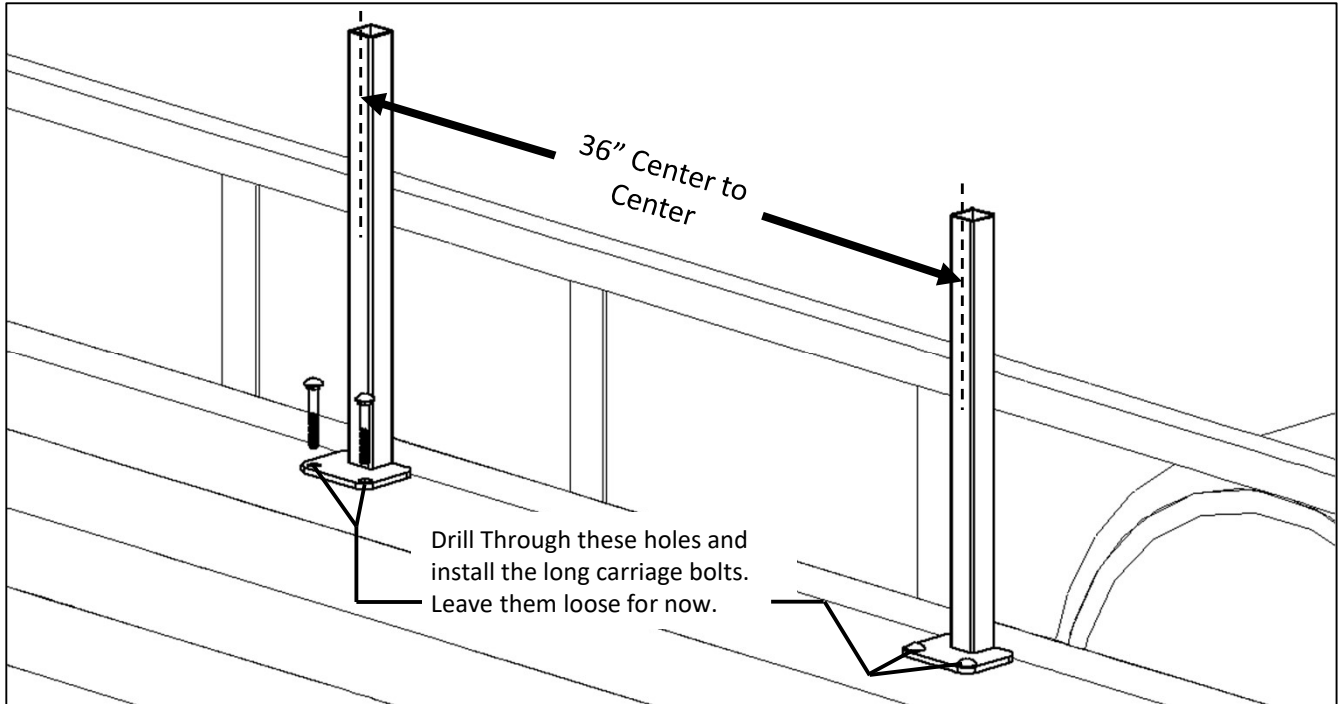

Step 2: Install the "U" brackets. Use a square to hold the post straight and mark the top rail of the trailer then hold the "U" bracket in place and mark the hole location for drilling. Drill $5/16$ " holes and install the "U" brackets tighten all of the bolts. **Note: The mounting posts must be parallel for your trimmer rack to function properly.**

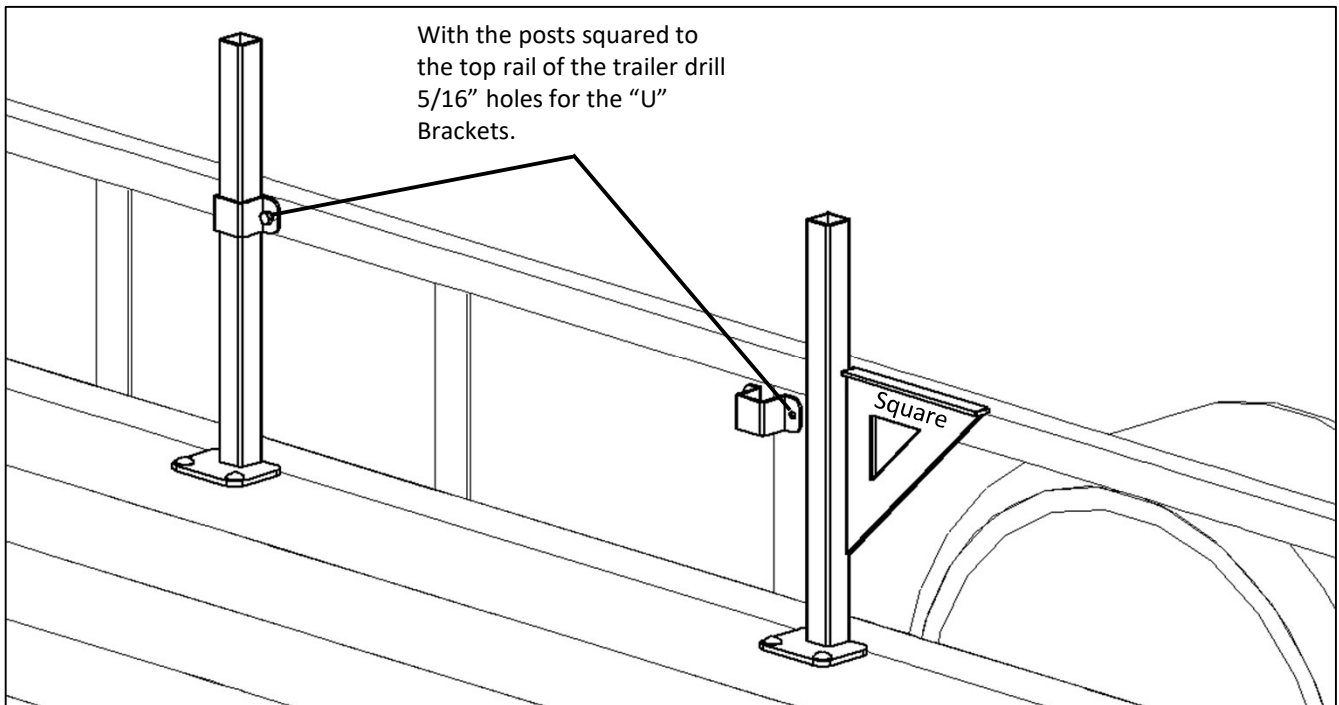

Mounting on Open Trailers (Continued)

Step 3: Cut the mounting posts. Mark the mounting posts at the desired height and cut them off.
Note: They must be a minimum of 6 inches above the rail and they both have to be the same length.

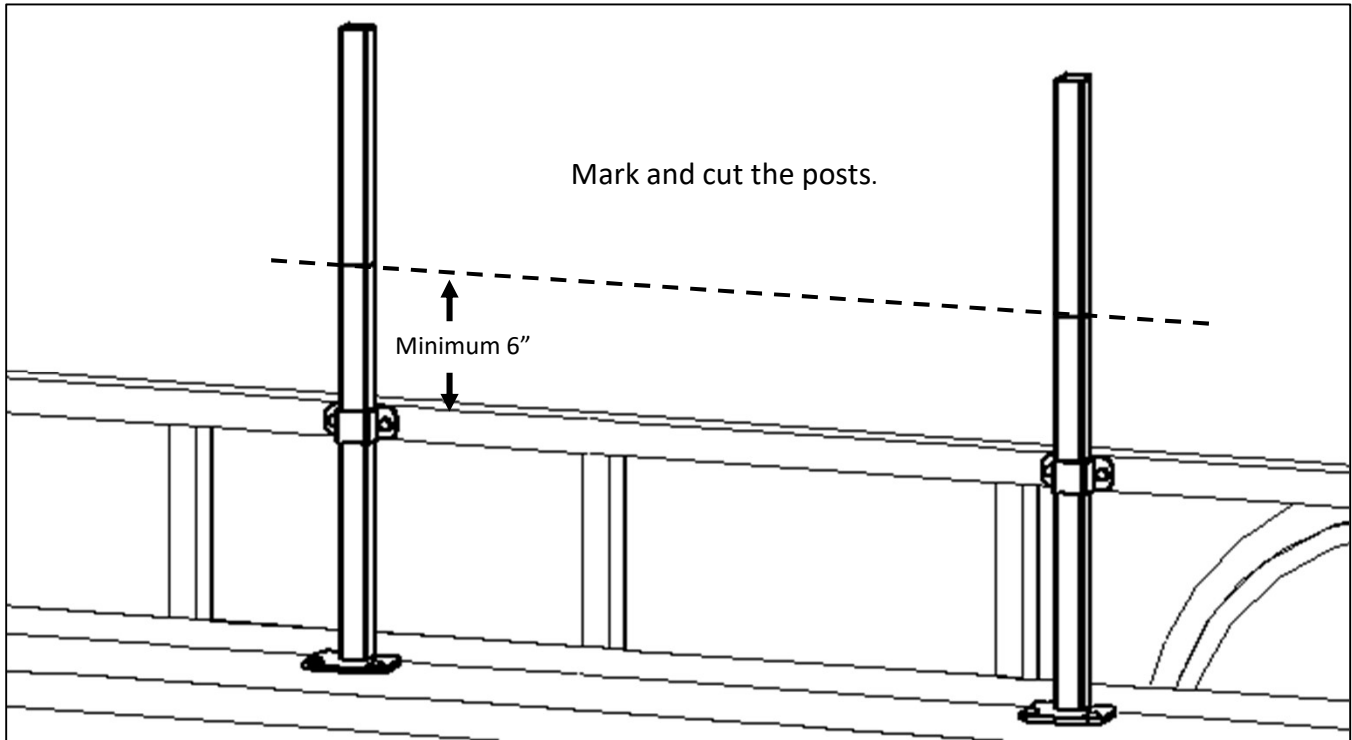

Step 4: Install the trimmer racks onto the mounting posts. Place the trimmer racks onto the mounting posts and tighten the set screws. Make sure they are very tight. The set screws can be filled with epoxy for added security.

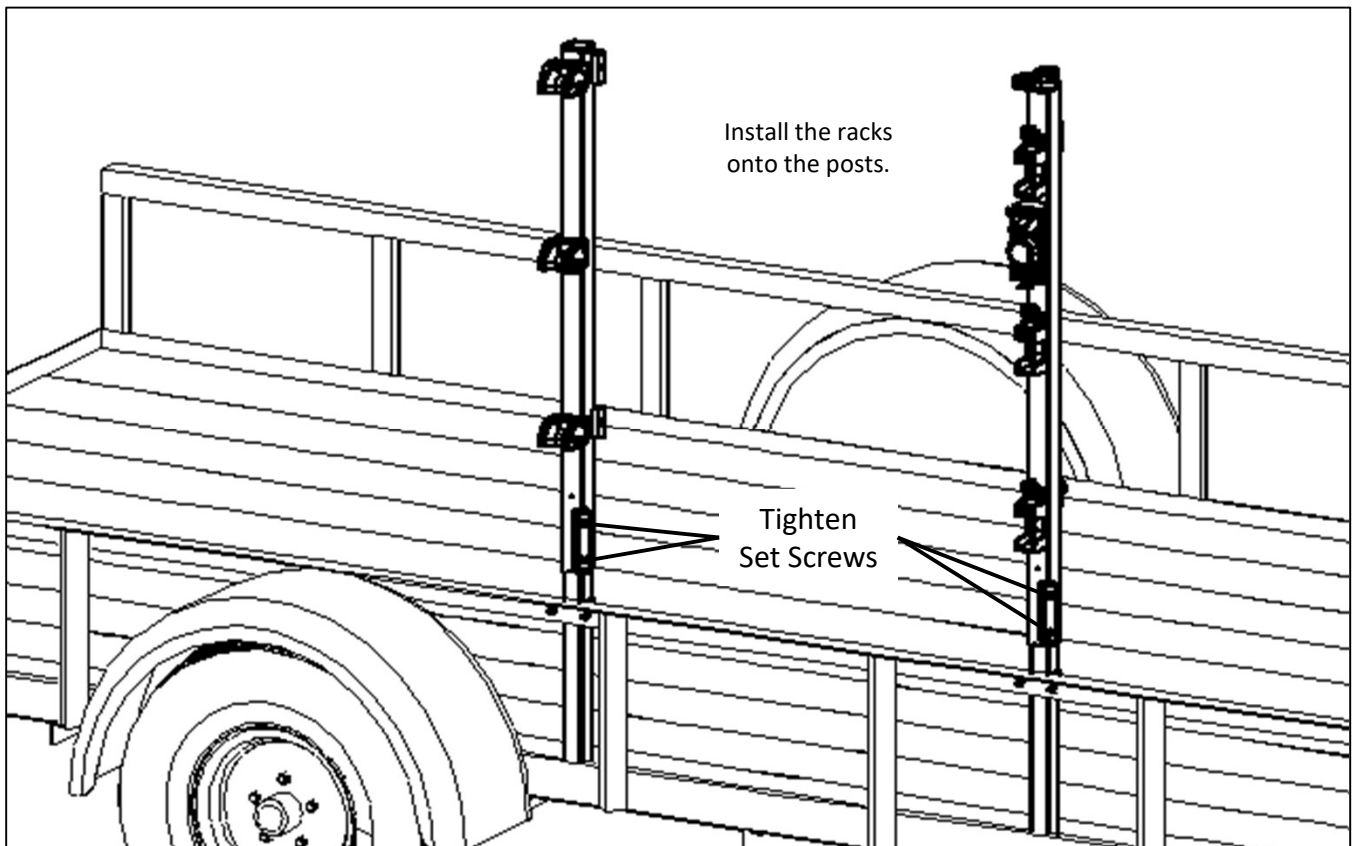

External Mounting Bracket Option (sold separately)

The external mounting bracket option allows racks to be mounted on the outside of the rail which means they can be lowered, this is very useful for 4 position trimmer racks. The exterior mounting bracket option also allows the racks height to be adjusted so you can mount a rack to the outside of your trailer without lowering it if you wish.

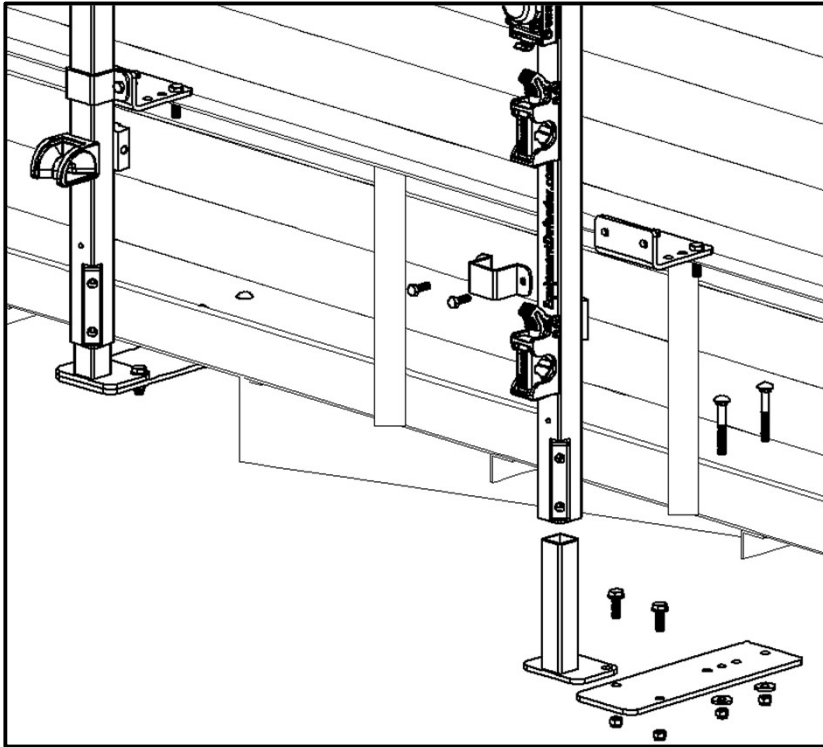

Showing the racks mounted externally and lowered

Showing the racks mounted externally and normal height

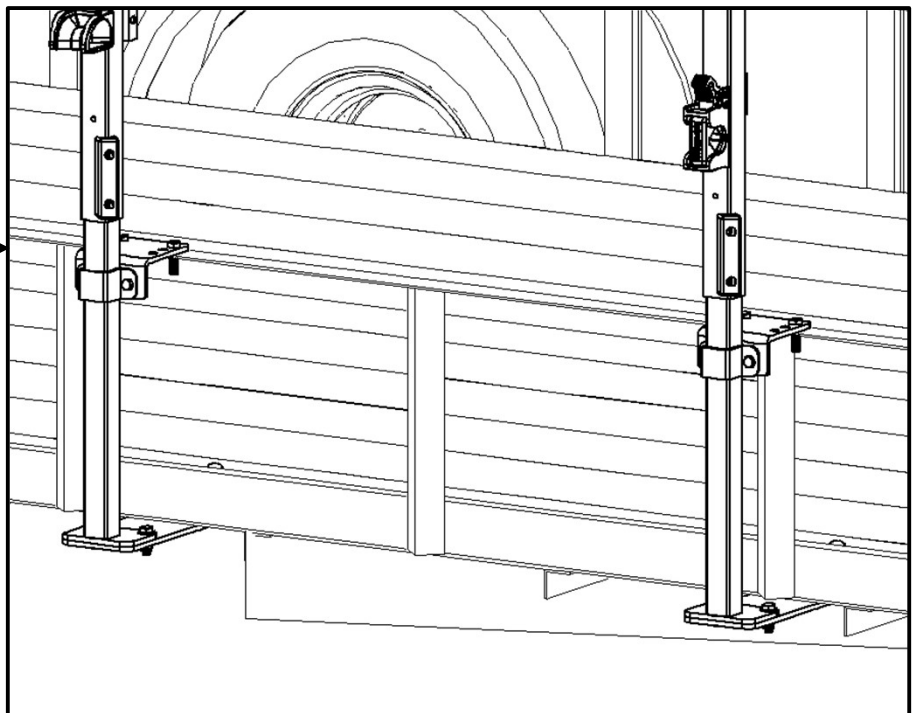

Mounting on Enclosed Trailers

Step 1: Install enclosed trailer brackets onto the trimmer rack.

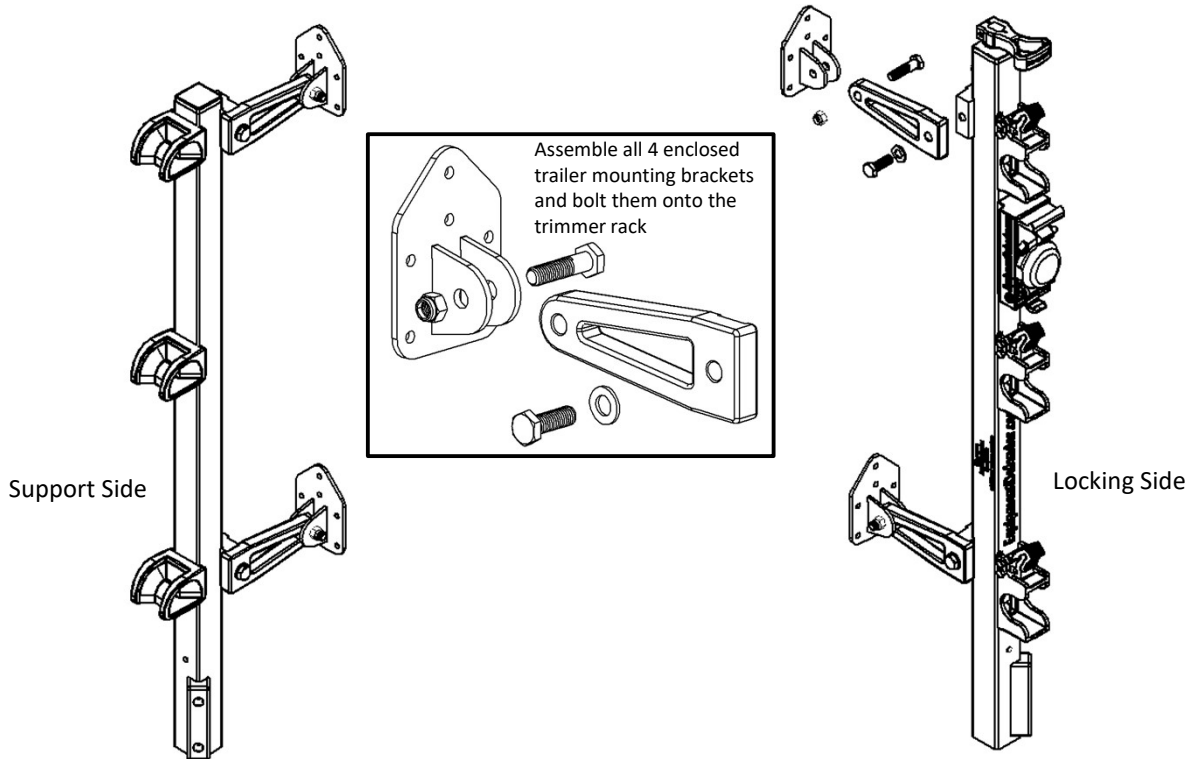

Step 2: Screw the brackets for the locking side onto the wall. Starting with the locking side, screw through the plywood and into the frame of the trailer. **Note: check to make sure the screws aren't going to go through the outside wall of your trailer.** Install as many screws as you can then remove the bracket from the rack and install the rest.

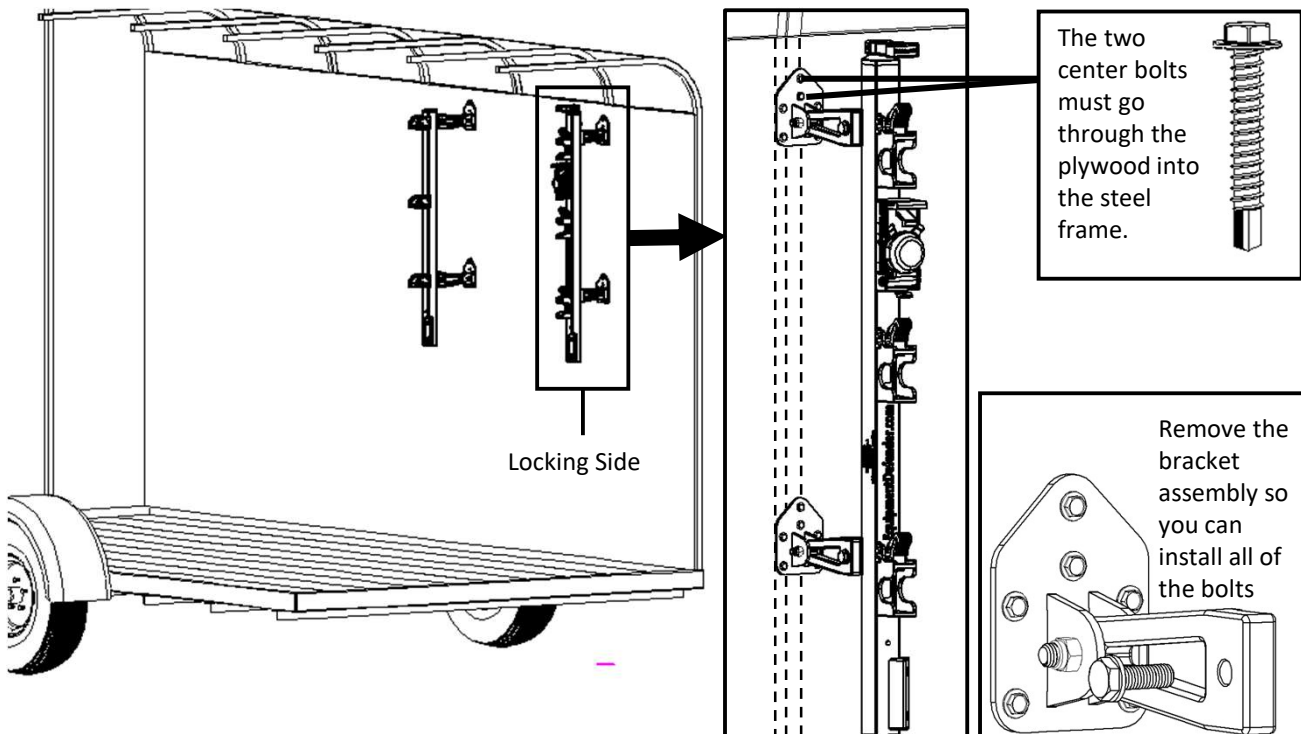

Mounting on Enclosed Trailers (Continued)

Step 3: Screw the brackets for the support side onto the wall approximately 36 inches apart center to center, this dimension can be increased or decreased to suit your needs. Keep in mind, if you are setting up multiple trailers this dimension should be the same on all so your equipment can be interchanged. If you can't screw the support side into the steel frame or if you wish to mount the rack in a location where there is no steel frame it will be okay as long as the plywood is at least $\frac{1}{2}$ " thick and you must use all screw holes.

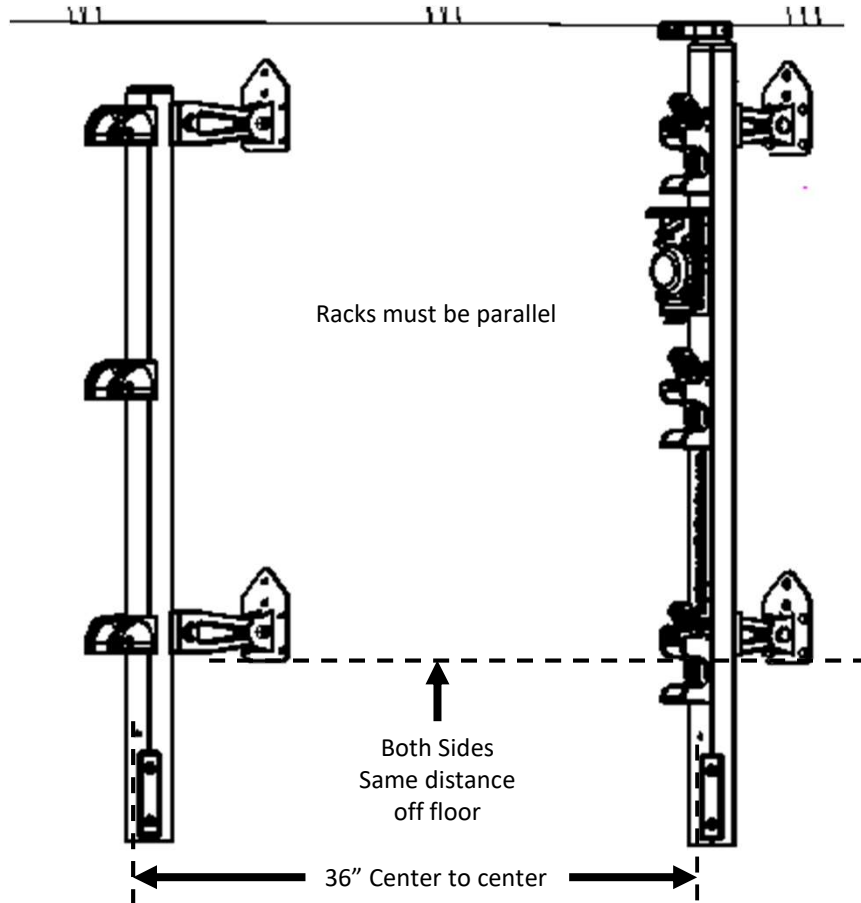

Install Engine Support

Step 1: Assemble the engine support.

Assemble all positions and don't make too tight for now they will be adjusted later

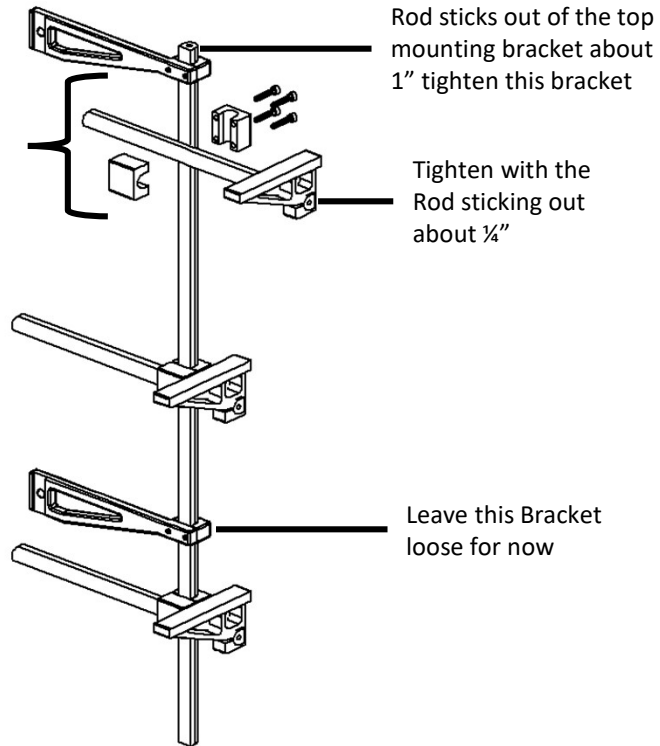

Step 1: Install the engine support onto the locking side. Install the top bolt first then slide the bottom bracket into position and install the bottom bolt. Tighten the bottom bracket so it can't slide.

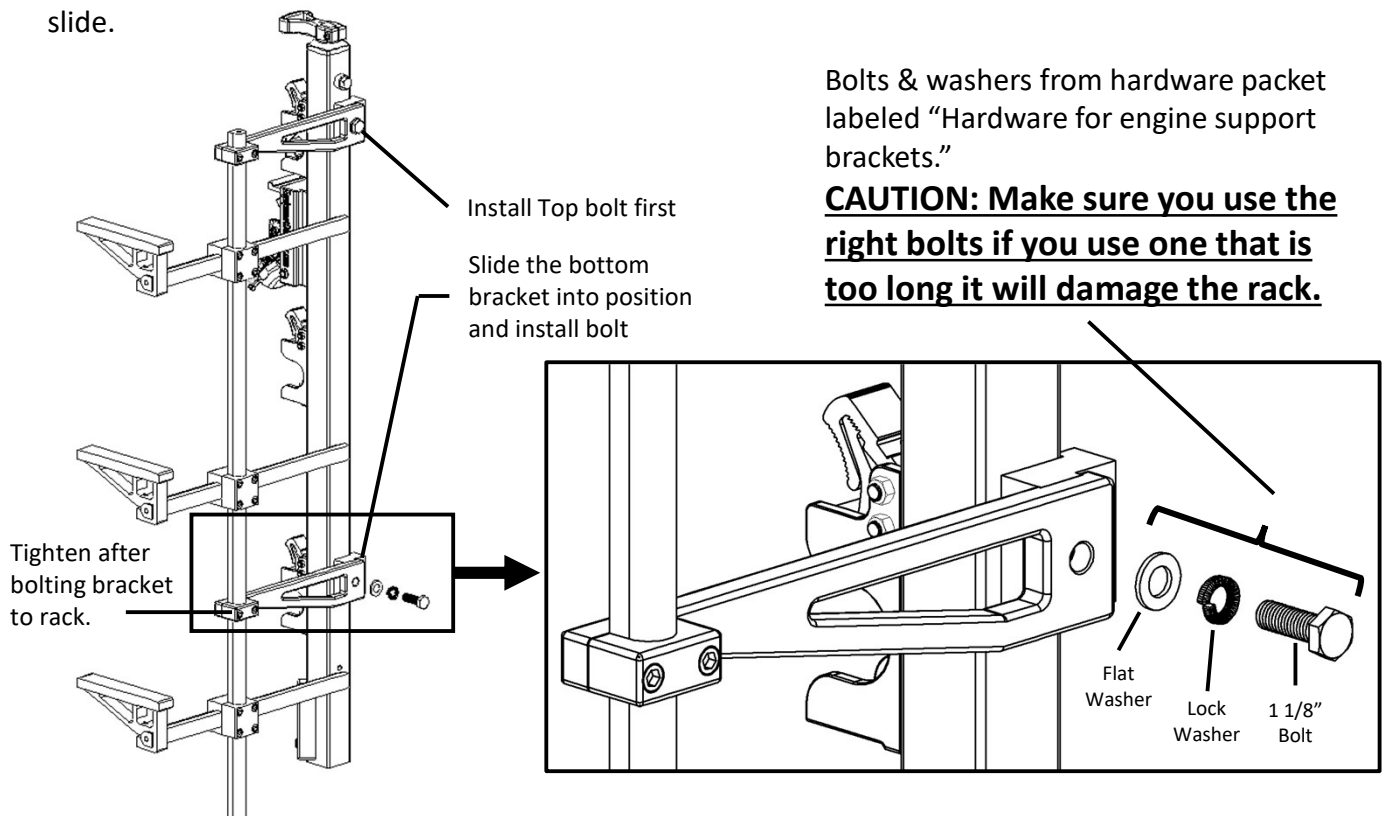

Install Shaft Brackets

Step 1: Install the shaft brackets on your equipment

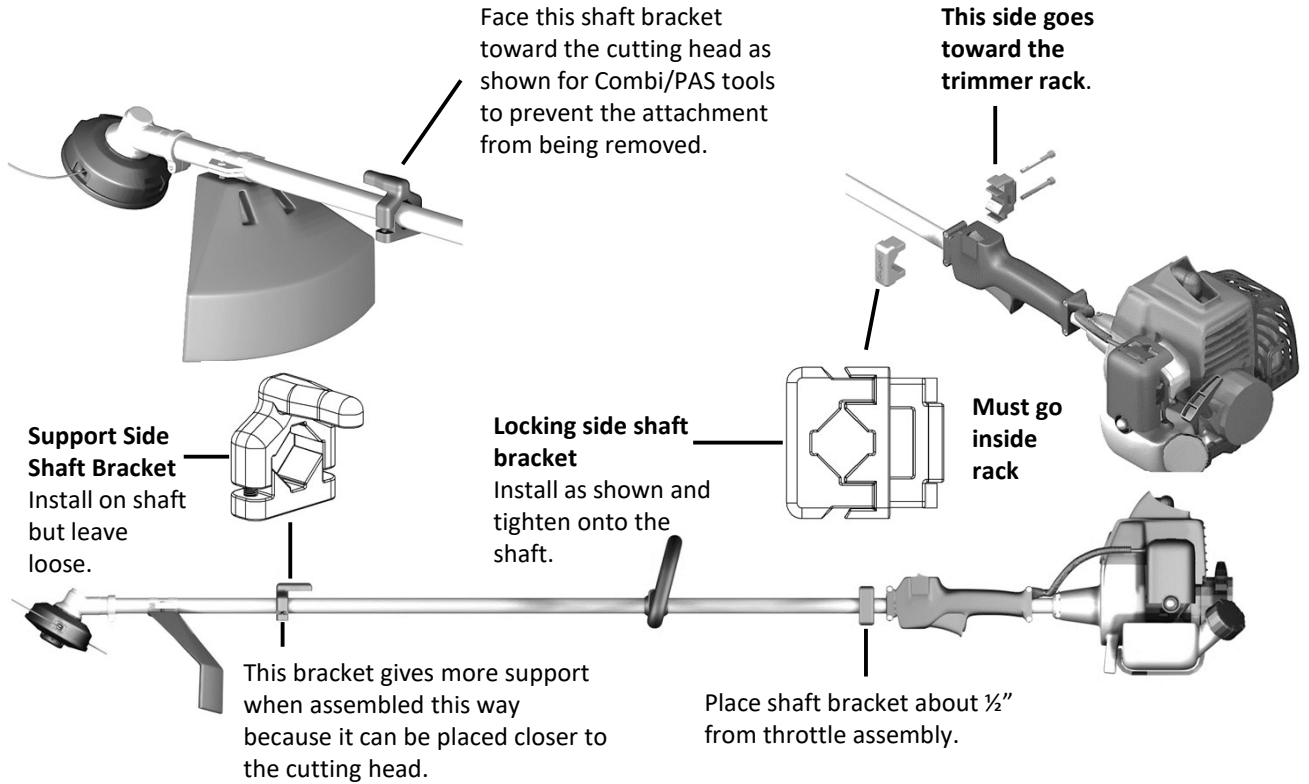

Step 2: Place the trimmer into the rack and adjust the support side shaft bracket

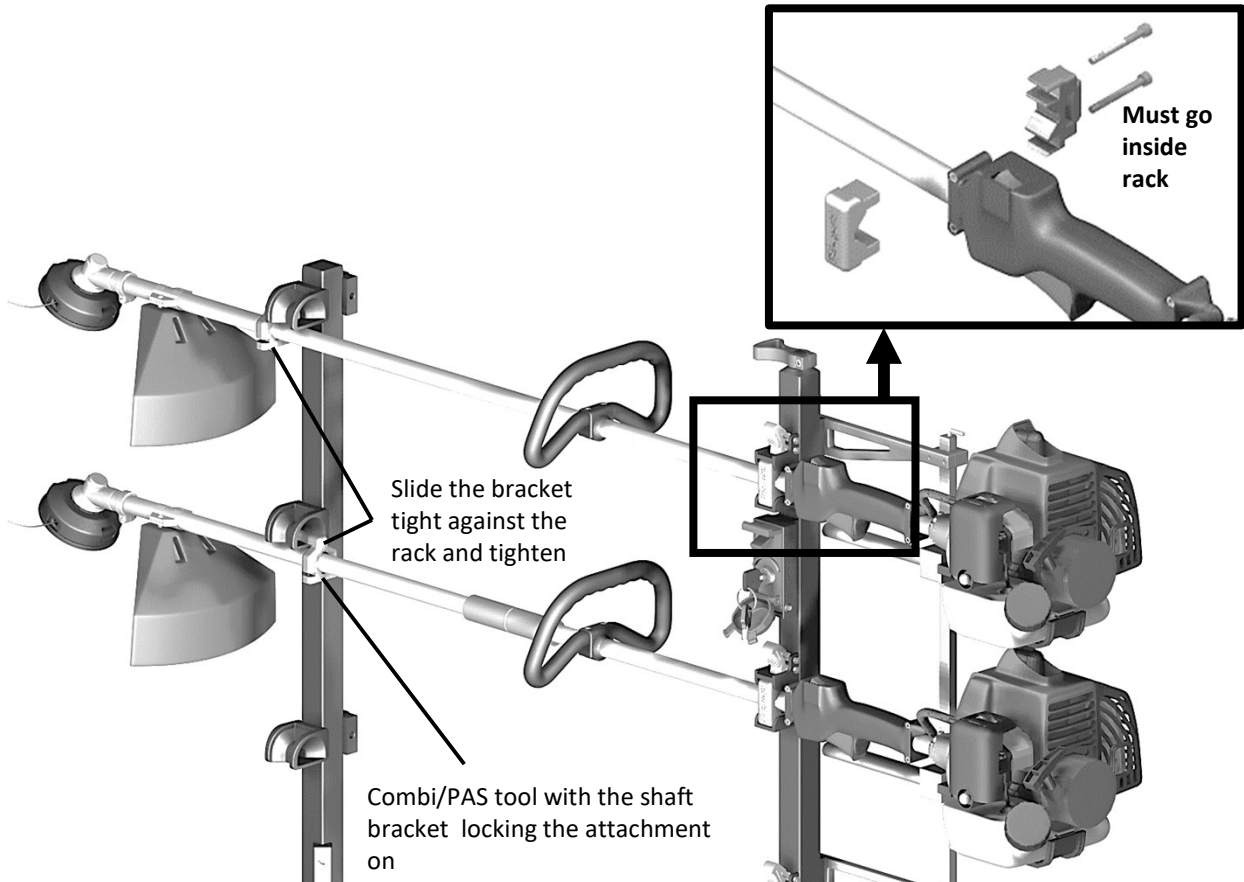

Adjust Engine Support

With the line trimmers secured in the rack, adjust the engine supports so there is no engine weight on the shaft. The support can be placed under any solid component on the engine.

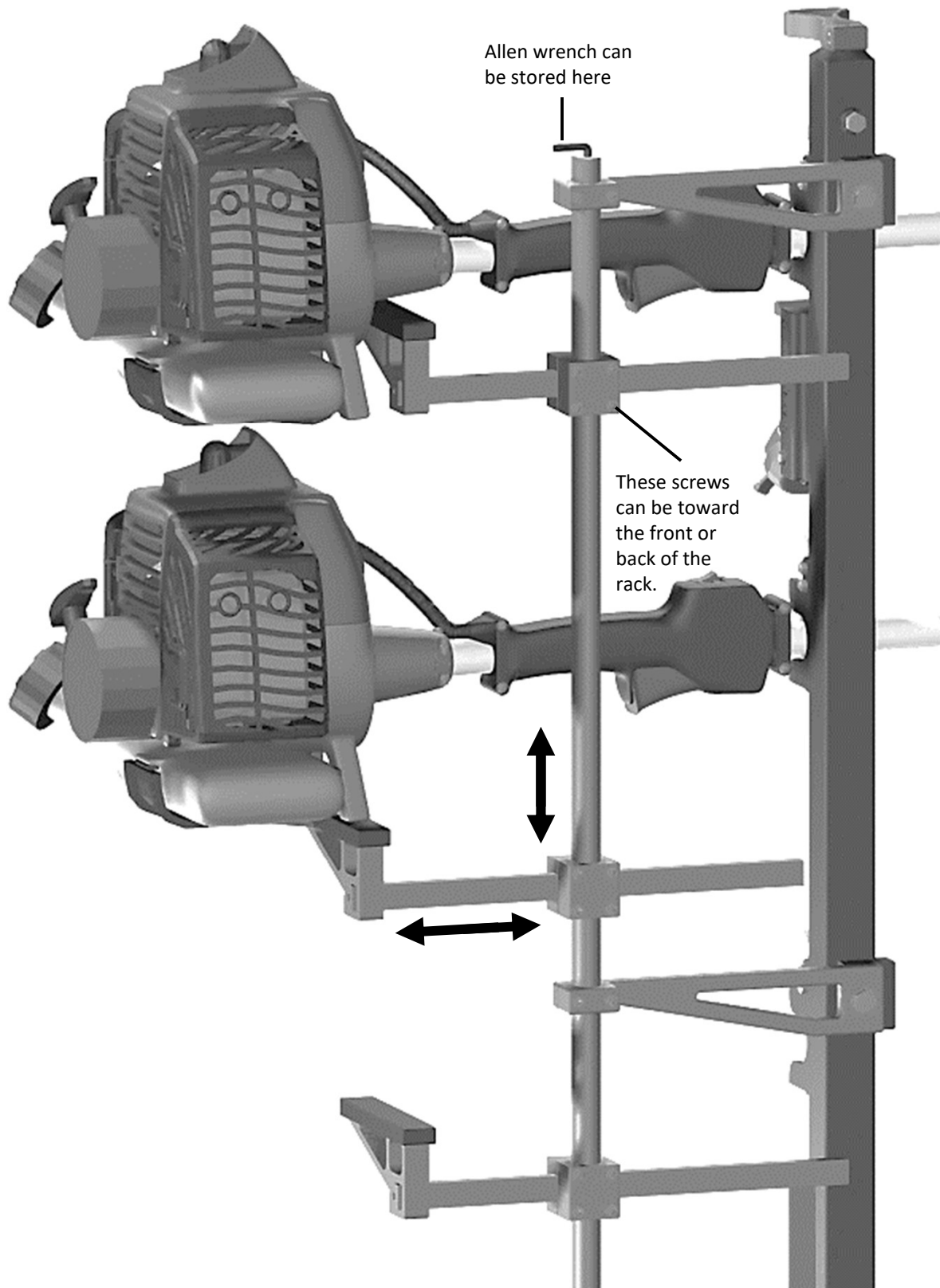

Using the Trimmer Rack

Locking/Unlocking the rack.

- The red handle at the top of the rack locks/unlocks all trimmers at the same time, rotating it to the left unlocks, straight forward locks.
- Before the handle can be rotated unlock the key or (optional combination) lock and open the red door.
- The keyed lock or (optional Combination) lock can be left in the unlocked position and the operator can simply open the door and rotate the handle; this feature provides a good level of security without having to locate keys making it very fast to use.
- **Fully lock the rack by using the Key / combination lock for maximum security.**

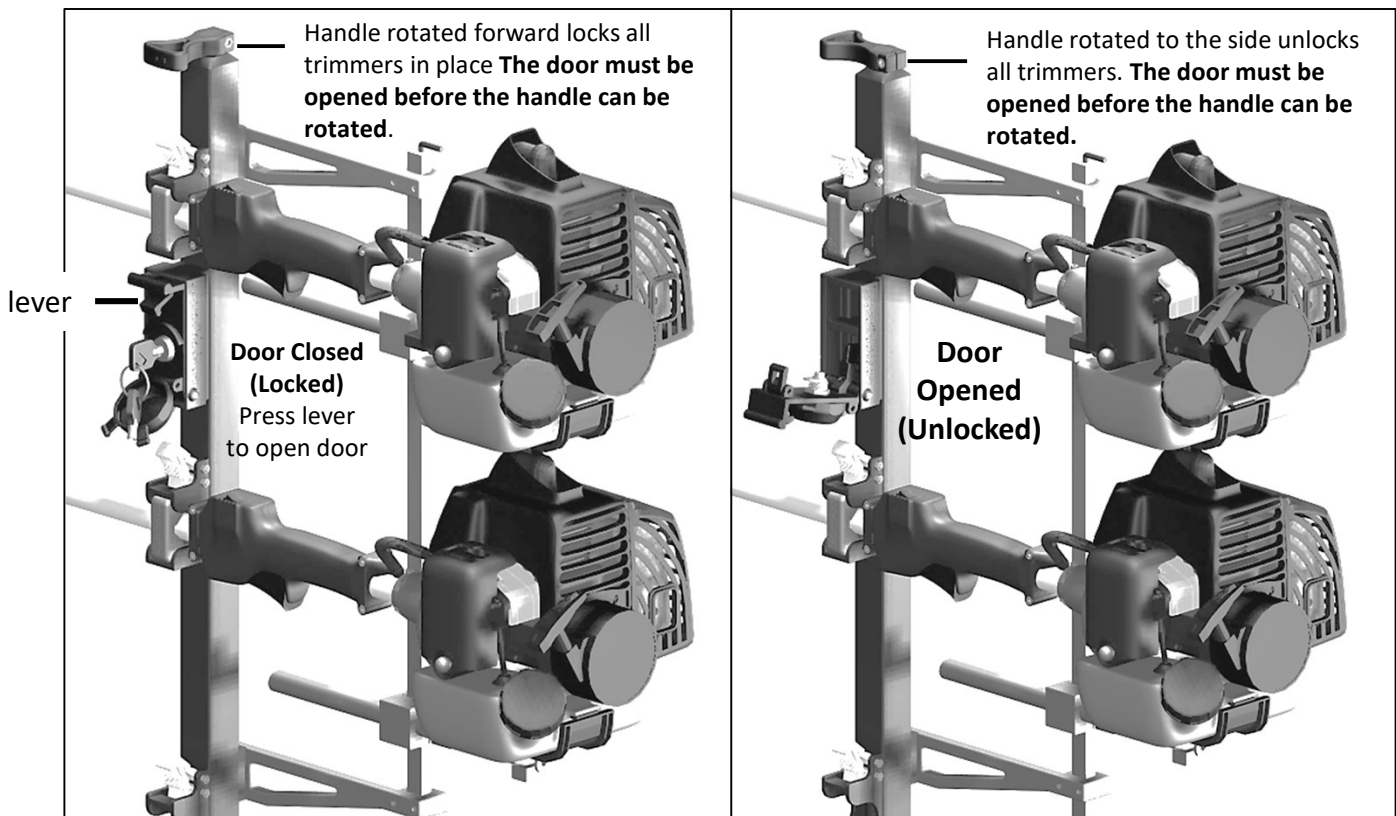

Optional combination lock can be purchased online:
EquipmentDefender.com

Instructions for setting your personal combination:

- The combination is factory set at >>0-0-0-0<<
- Combination must be on opening number prior to resetting
- On the underside outer edge of the lock there is a hole for the code reset button. Rotate the face of cam until the code reset button comes into view.
- Push this pin in with a paper clip and keep it pushed in
- Set your personal combination by turning the dials to the desired combination – starting with the dial marked '1', and moving to '2', '3', and then '4'.
- Release the reset button and your combination is set.
- To lock, rotate lock to "locked" position. Rotate one or more dials after lock is closed. To open the lock, turn dials to your personal combination.