

AFTER-SALE SERVICE

Purchase Date	(Year)	(Month)	(Date)
Warranty Period			
Purchase Store			

Please paste the store's stamp and guarantee barcode here, Please notice the purchase date should be confirmed when you buy the product.

WARRANTY SERVICE

Please follow the below solutions to confirm the defective problems before asking for warranty service.

Phenomenon	Solution
Separate bulb	Light off Defective lamp body: please connect a new lamp body with the original driver, if it works well, then it means the previous lamp body is defective, please cut down the power line of the defective lamp body for warranty.
	Light off Defective driver: please connect another new driver with the original lamp body, if it works well, then it means the previous driver is defective, please cut down the power line of the defective driver for warranty.
	Abnormal light Please connect suitable canbus decoder to solve the canbus problem.
	Flicking Please connect suitable canbus decoder to solve the canbus problem.
ALL in one bulb	Flicking If encounter the situation when lighting up the bulb for some times it do not work suddenly, and then turn off the power start it again work well, please change the dust cover with more space for heat dissipation to solve it.
	Flicking Please connect suitable canbus decoder to solve the canbus problem.
	Light off Please make sure of correct installation, if the lamp body is still not work, please cut down the power line of the defective lamp body for warranty.
	Abnormal light Please connect suitable canbus decoder to solve the canbus problem.
Flicking If encounter the situation when lighting up the bulb for some times it do not work suddenly, and then turn off the power start it again work well, please change the dust cover with more space for heat dissipation to solve it.	

Attention:

The following conditions are beyond warranty scope.

- Canbus problem:** when replace the original halogen bulb with LED bulb, some vehicles may meet with canbus problem like light flickering etc, please connect suitable decoder to solve the canbus problems.
- Man-made reason:** man-made reason lead to broken led chip, chapped wire, user modify or repair the bulb themselves etc.
- Installation problem:** some vehicles may can not install our product because of small installation space or installation position doesn't fit etc.
- Natural disaster:** damage because of irresistible natural disaster like earthquake, flood etc.

WARRANTY SERVICE

Thank you for being the best part of NOVSIIGHT.

Please contact us if there is any problem with headlights, we will response you in 24 hours.



NOVSIIGHT
AUTO LIGHTING

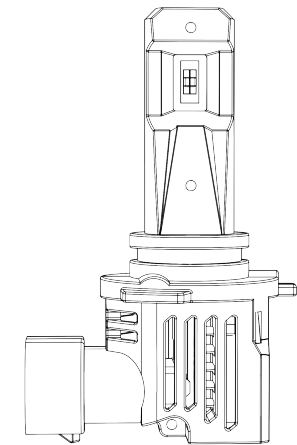

PRODUCT MANUAL

H7

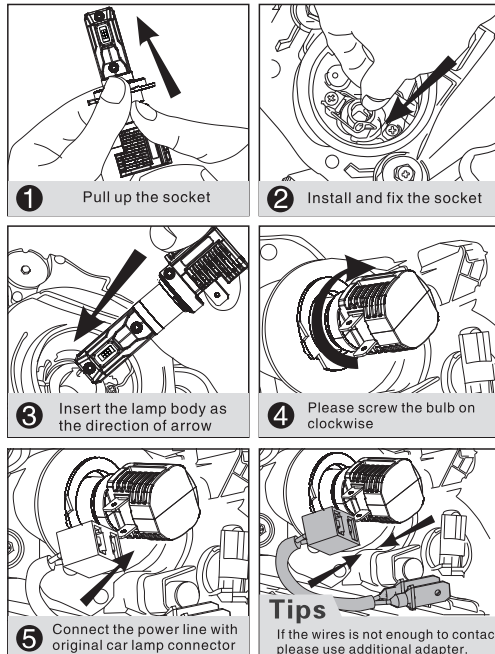

H4/H1/H3

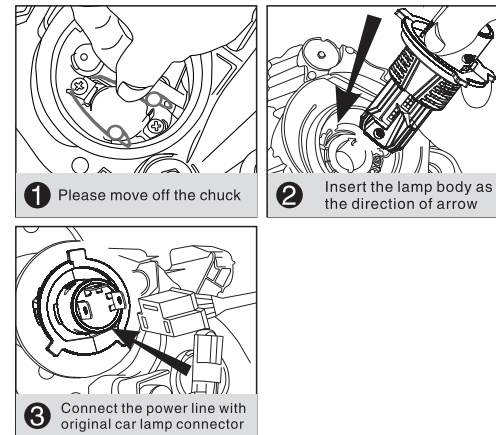

H8/H9/H10/H11/H13/9004/9005/9006/9007/880/881

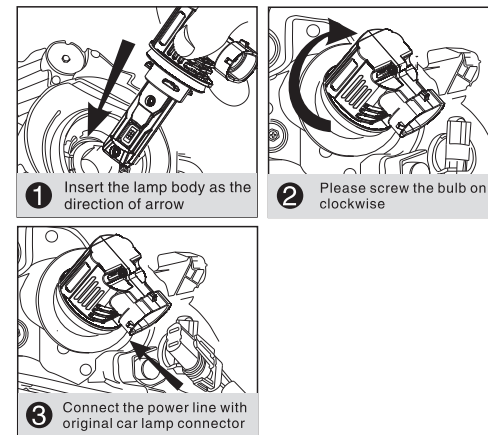

PRODUCT SPECIFICATION

Operating Voltage	DC9-32V
IP Rate	IP68
Color Temperature	6500K
Heat Dissipation Theory	Aviation aluminum ADC12
Operating Life	>100000hrs
Operating Temperature	-40°C~+80°C