

AFTER-SALE SERVICE

Purchase Date	(Year)	(Month)	(Date)
Warranty Period			
Purchase Store			

Please paste the store's stamp and guarantee barcode here, Please notice the purchase date should be confirmed when you buy the product.

WARRANTY SERVICE

Please follow the below solutions to confirm the defective problems before asking for warranty service.

Phenomenon	Solution
Separate bulb	Light off Defective lamp body: please connect a new lamp body with the original driver, if it works well, then it means the previous lamp body is defective, please cut down the power line of the defective lamp body for warranty.
	Light off Defective driver: please connect another new driver with the original lamp body, if it works well, then it means the previous driver is defective, please cut down the power line of the defective driver for warranty.
	Abnormal light Please connect suitable canbus decoder to solve the canbus problem.
	Flicking Please connect suitable canbus decoder to solve the canbus problem.
ALL in one bulb	Flicking If encounter the situation when lighting up the bulb for some times it do not work suddenly, and then turn off the power start it again work well, please change the dust cover with more space for heat dissipation to solve it.
	Flicking Please connect suitable canbus decoder to solve the canbus problem.
	Light off Please make sure of correct installation, if the lamp body is still not work, please cut down the power line of the defective lamp body for warranty.
	Abnormal light Please connect suitable canbus decoder to solve the canbus problem.
Flicking If encounter the situation when lighting up the bulb for some times it do not work suddenly, and then turn off the power start it again work well, please change the dust cover with more space for heat dissipation to solve it.	

Attention:

The following conditions are beyond warranty scope.

1. Canbus problem: when replace the original halogen bulb with LED bulb, some vehicles may meet with canbus problem like light flickering etc, please connect suitable decoder to solve the canbus problems.
2. Man-made reason: man-made reason lead to broken led chip, chapped wire, user modify or repair the bulb themselves etc.
3. Installation problem: some vehicles may can not install our product because of small installation space or installation position doesn't fit etc.
4. Natural disaster: damage because of irresistible natural disaster like earthquake, flood etc.

WARRANTY SERVICE

Thanks for using our products!
If the product is failure, please kindly follow the below steps, so that we could help to solve the problem for you at the shortest time.



Defective lamp body and driver

Please cut down the two sides connect wires, then send back the picture to us. (Picture with barcode is necessary)

NOV'SIGHT

AUTO LIGHTING

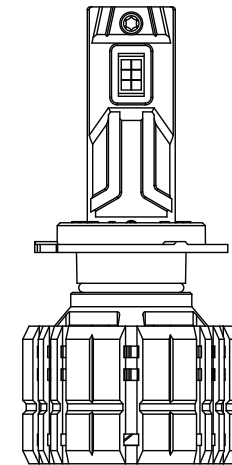

PRODUCT MANUAL

H1/H3/H4/H7/H13/9004/9007

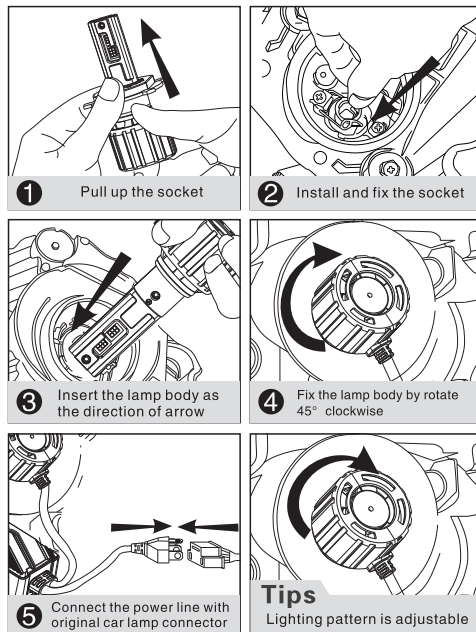

H8/H11/H16JP/P13/9005/9006/9012/PSX26/880/881

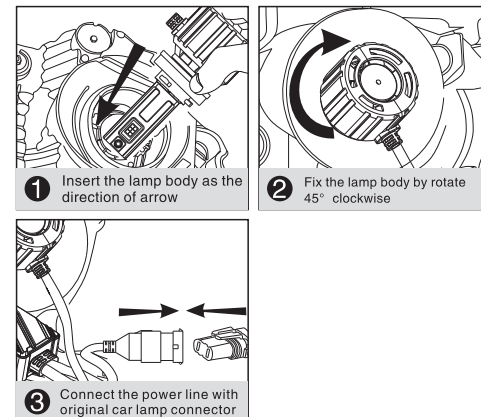

H16EU/PSX24

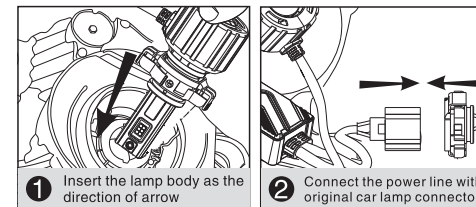

REMIIND

Please keep the led chip symmetry and hood upwards as the photo show. If light pattern is not good, please rotate the body by tool.

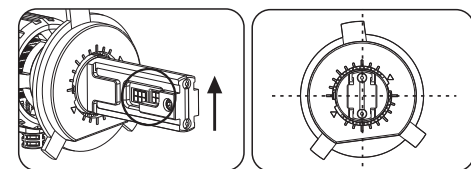

PRODUCT SPECIFICATION

Operating Voltage	DC9-32V
IP Rate	IP68
Light Source Model	7545
Color Temperature	6500K
Heat Dissipation Theory	Aviation aluminum 6063
Operating Life	>100000hrs
Operating Temperature	-40°C ~ +80°C