

BAYSIDE
8 Ft x 3 Ft.
MODEL B83

MODEL SPECIFIC INSTRUCTION MANUAL

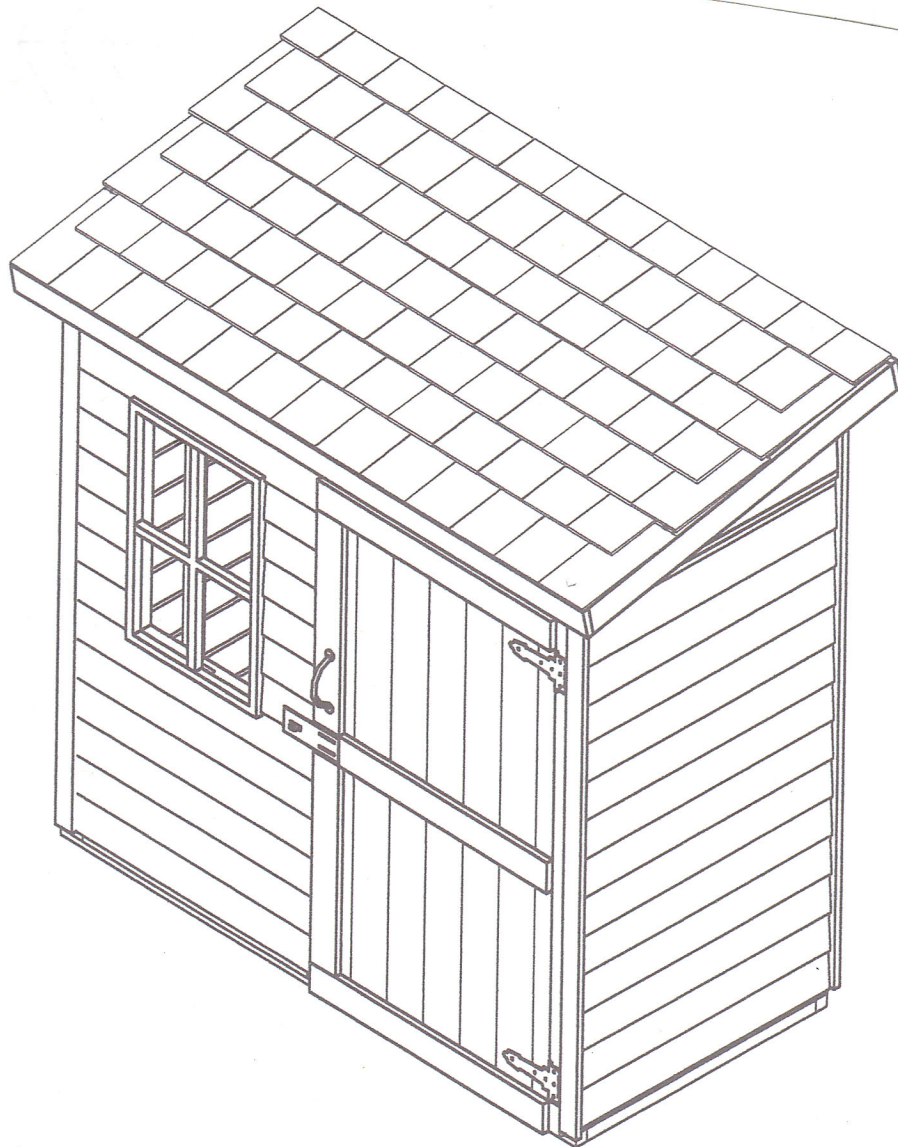

ACCESSORIES AND HARDWARE

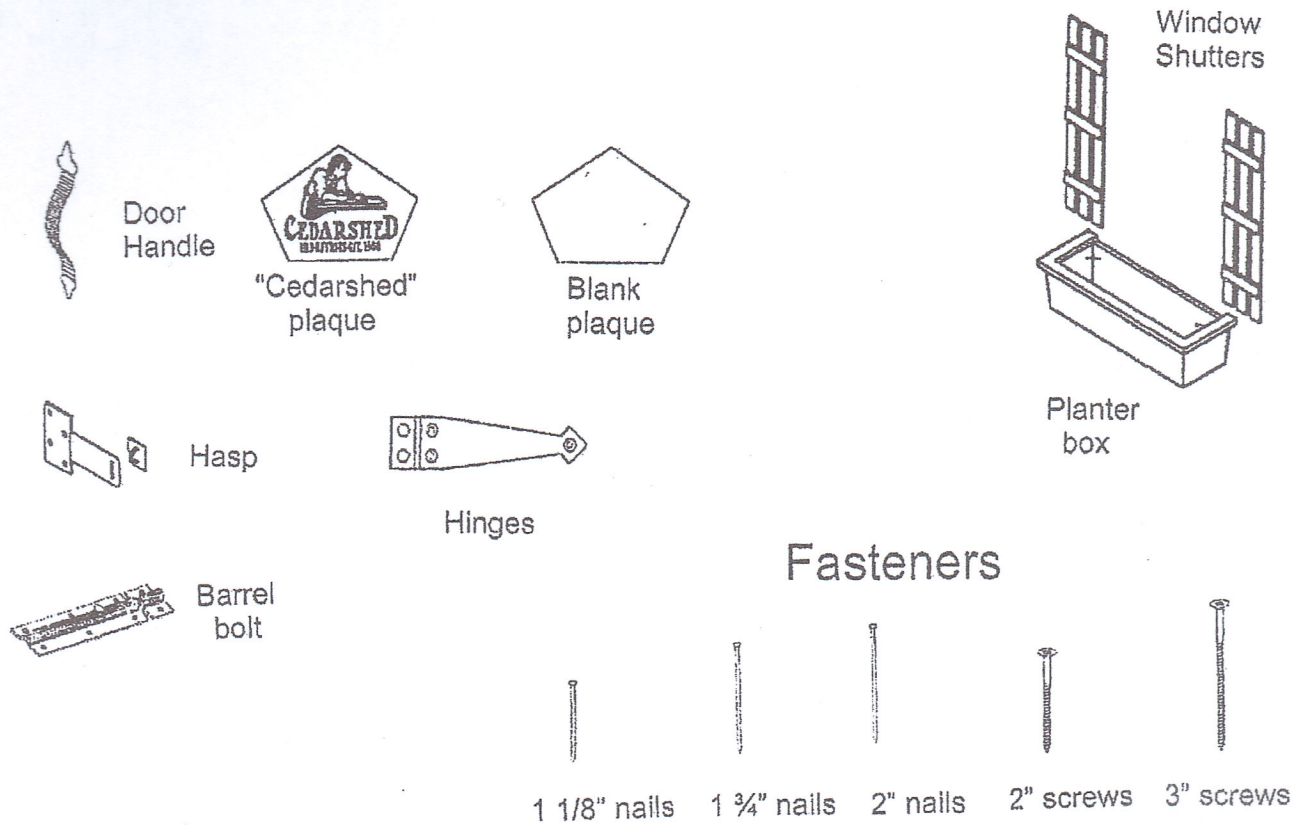

B83

PART #	DESCRIPTION	DIMENSIONS (where app.)	# OF PCS
ACCESSORIES			
P-H-PLAQS	plaque	square CS plaque	1
P-H - MFLASS	Metal roof flashing	3" x 12"	8
FASTENERS			
P-H-NL1.75	1 3/4" nails	1 3/4"	160
P-H-SC3	brown screws	3"	30
P-H-SC3Z	zinc screws	3"	120
P-H-SC2	2" screws	2"	54

DOOR PARTS AND HARDWARE			
DR-006	Dutch door	34 1/2 x 74 3/4	1
P-H-THING4	4" hinges	4" hinges	4
P-BBLT4	barrol bolt	barrol bolt	1
P-H-DHAND	door handle	6"	1
P-H-HASP	hasp	hasp	1
Instruction manual, questionnaire and driver bit			

FOUNDATION PREPARATION

PREPARE THE SITE:

Before you begin assembly, clear the construction area. Remove all organic material such as roots grass, dirt and large rocks that may compromise the ability to level the site. Make sure the ground slopes away from the site at least 10 ft. (3.05 m.) in all directions. If necessary, build up the centre of the site and slope away from the high point to provide drainage. Fill in any low spots within the perimeter of the site. Be sure to use gravel or a good packing material to level the site. Make sure it is packed down before beginning the building process.

FIUNDATION CHOICES:

1. Concrete Patio Stones (not included)

If the ground is stable and has sufficient drainage, you can set patio stones directly on a firm compacted gravel base. Make sure the stones are thick enough to allow air circulation under the structure. This helps to prevent dry rot from setting in on the joist. The bearing points are outlined in the next page of this manual.

2. PRESSURE TREATED WOOD STRINGERS (not included)

A second option is to use 4x4 (90 mm x 90 mm) stringers which can run the full width of the structure. Be sure to use a stringer every 4 ft. For example for an 8x12 floor structure, you will need 4-8 ft. stringers. This reduces the amount of leveling needed as you only need to level each end of the stringer. However, it will increase the height of the shed and you may require a ramp or an additional step at the doorways.

3. CONCRETE SLAB

Typically a slab 3"-4" (75 - 102 mm) thick laid over a subbase of 4" (102 mm) of gravel or crushed rock is sufficient but may vary (consult your local Home Centre). Either mix your own concrete or have it delivered to your site. A 10' x 10' x 4" (3.05 m. x 3.05 m. x 10.2 cm.) slab will require approximately 1 cubic yard (0.764 cubic metre) of concrete. In any case, make sure you excavate the slab area to a depth of 6" (15.2 cm.), use 4" (10.2 cm.) of gravel as your subbase. Welded wire mesh as reinforcing (optional) and 4" (10.2 cm.) of concrete (trowel to allow for drainage away from the centre high point). Still use 1" (2.54 cm.) thick patio stones on the concrete slab to allow adequate air circulation to keep the floor joist dry. This will prevent dry rot from setting in.

4. POURING CONCRETE PIER POINTS USING SAUNA TUBES

Another option would be the pouring of concrete pier points using sauna tubes. Using the next page as a guide, place sauna tubes into the ground at each of the bearing points. Make sure the tops of the sauna tubes are level with the other. You may also wish to inbed metal straps into the concrete. These straps will be nailed to the joist structure.

1. Foundation Preparation

BAYSIDE 8 x 3 (B83)

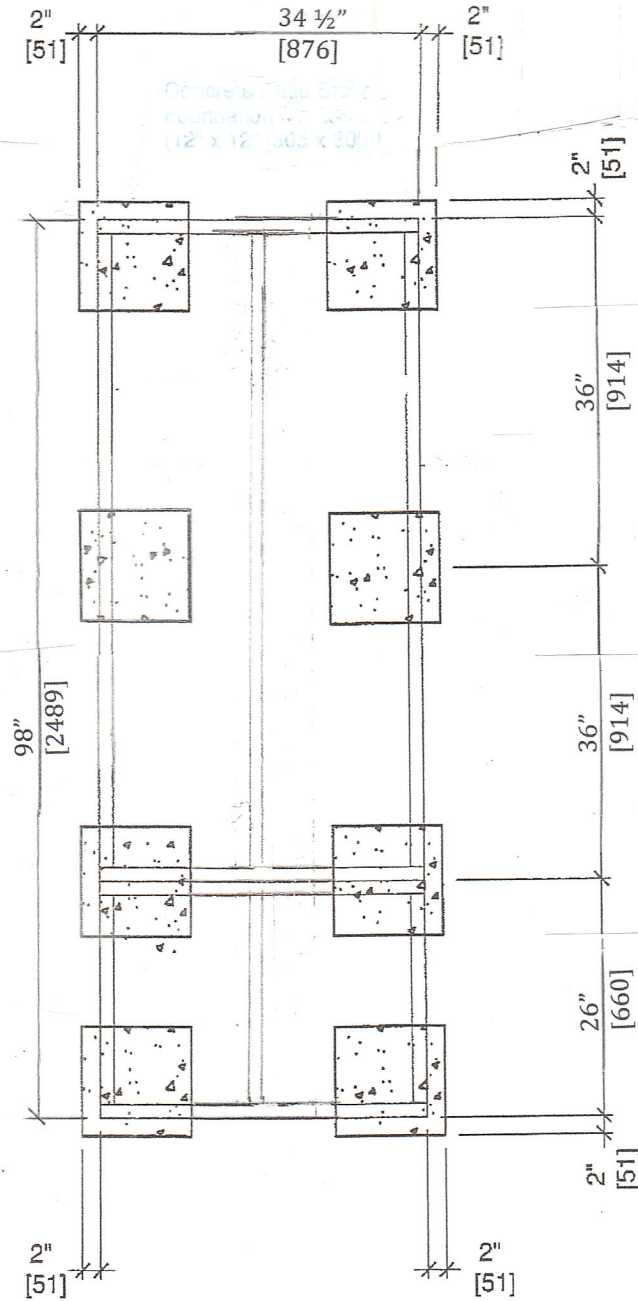

Foundation Plan

[Metric Dimensions shown in brackets]

FOUNDATION PREPARATION

1. Use a 2x3 or 2x4 straight piece of lumber on edge and a carpenter's level to level the perimeter patio stones. Add or remove soil under each stone until it is flush with the bottom of the 2x4 as shown in Fig. 1. Continue this procedure with the stones until you are satisfied all the stones are level with one another.

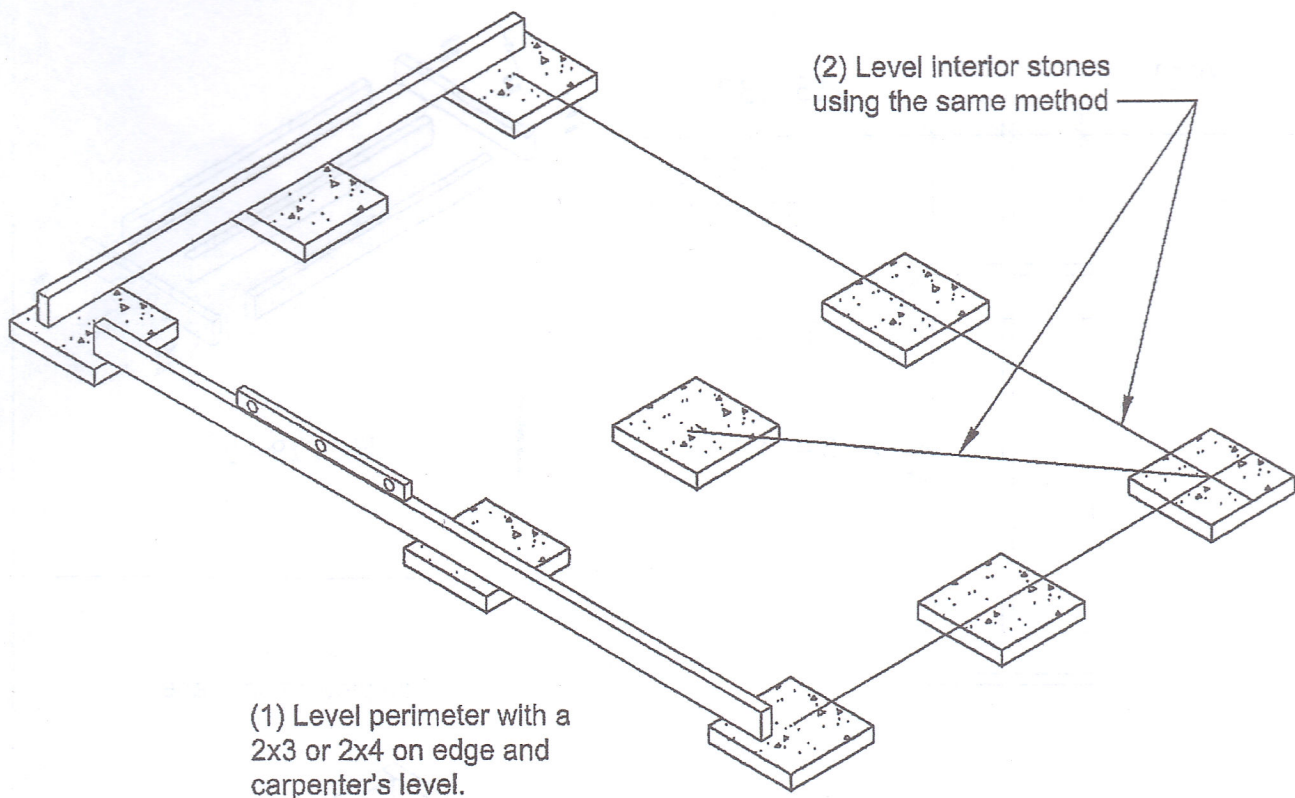

Fig. 1

Bayside 8 x 3

PART #	DESCRIPTION	DIMENSIONS (where app.)	# OF PCS	CODE
FLOOR PARTS				
P-2423	joist	2 x 4 x 23	3	
P-2434G	joist	2 x 4 x 34 1/2	4	
P-2469	joist	2 x 4 x 69	3	
P-PL-I2734G	plywood	5/8 x 27 x 34 1/2	3	
P-PL-I1734G	plywood	5/8 x 17 x 34 1/2	1	

34 1/2" x 26" Joist Box - P17

JOIST BOX ASSEMBLY

Lay the joist parts out as per Fig. P17 - 1. Using 2-3" screws per joint, assemble the joist box together as per Fig P17 - 2. The completed joist box is pictured in Fig. P17 - 3.

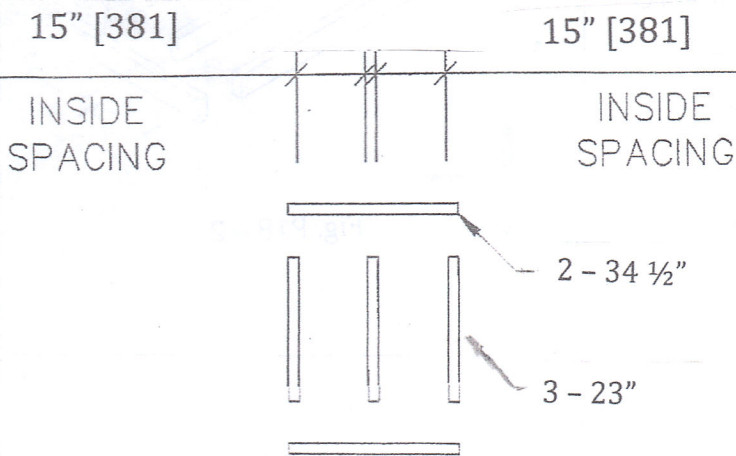

34 1/2" x 26" floor panel layout.
Fig. P17 - 1

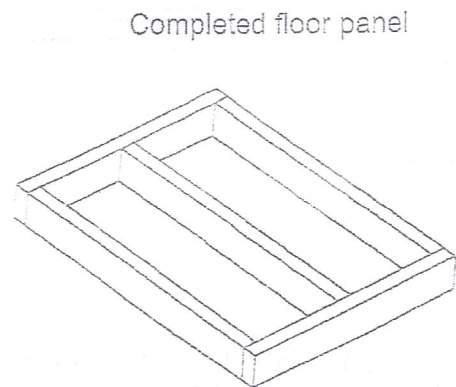
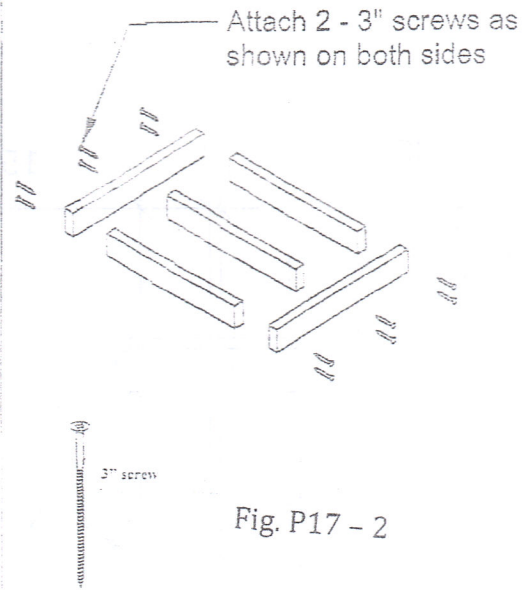
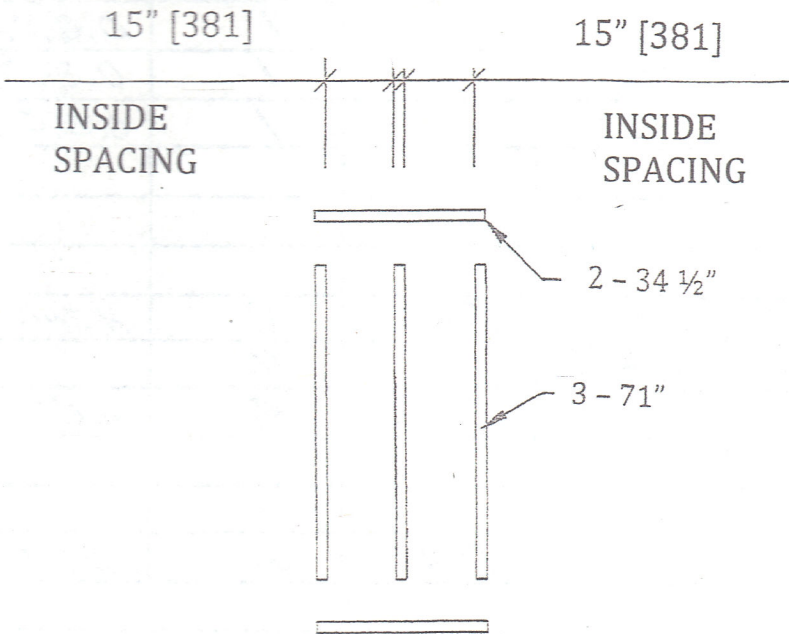

Fig. P17 - 3

34 1/2" x 72" Joist Box - P18

JOIST BOX ASSEMBLY

Lay the joist parts out as per Fig. P18 - 1. Using 2-3" screws per joint, assemble the joist box together as per Fig P18 - 2. The completed joist box is pictured in Fig. P18 - 3.



34 1/2" x 72" floor panel layout.
Fig. P18 - 1

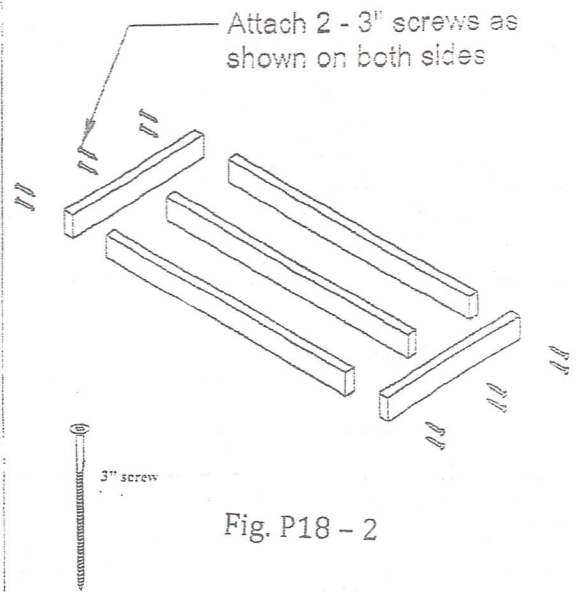

Fig. P18 - 2

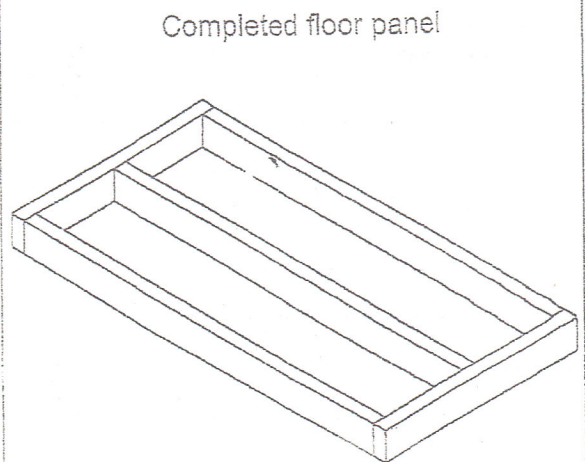

Fig. P18 - 3

FLOOR ASSEMBLY

Attach P-18 and P-17 joist boxes together using 6 - 3" screws. Please refer to Fig-1 and Fig-2 for details.

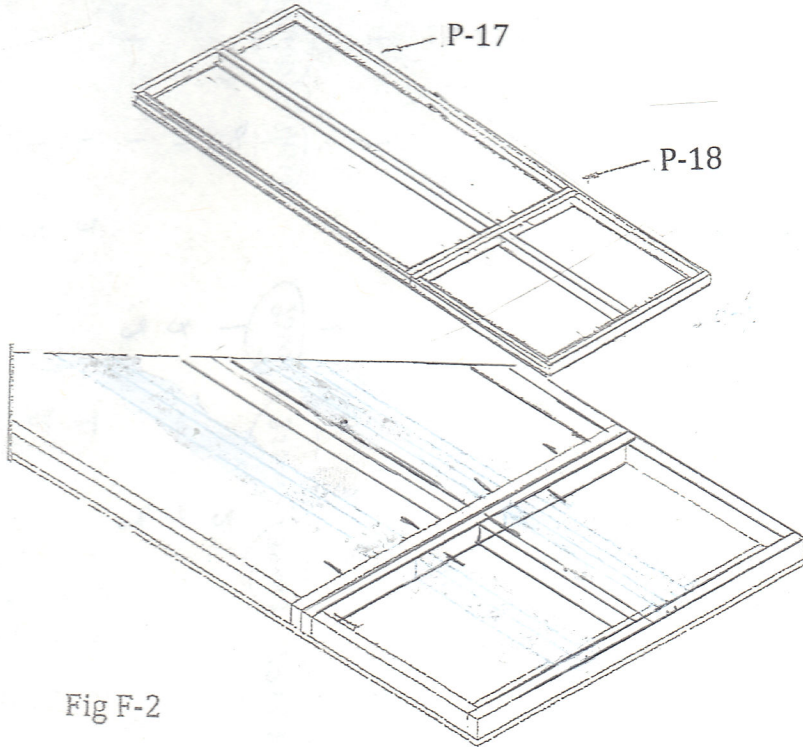

Fig F-2

Affix the plywood panels as per Fig-3 using 2" screws every 12" along each joist. The finished floor is shown in Fig-4.

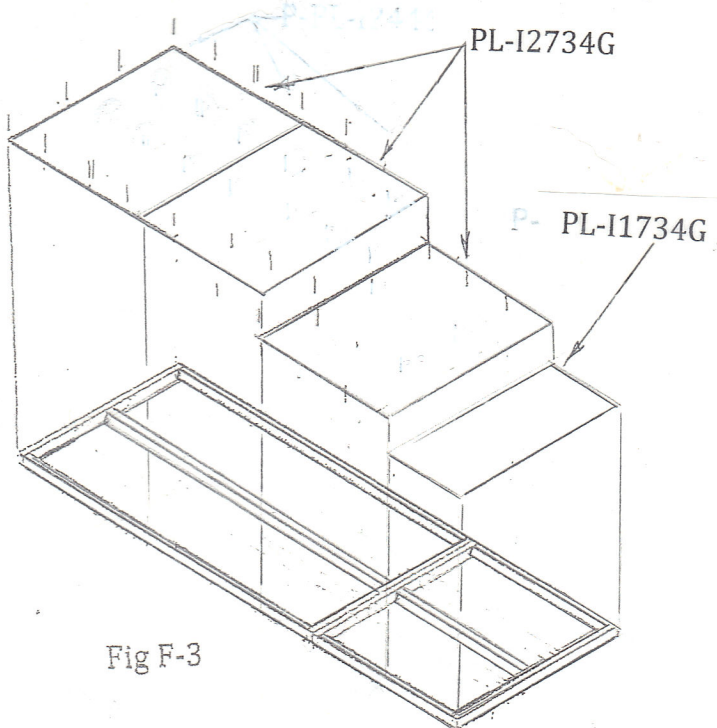

Fig F-3

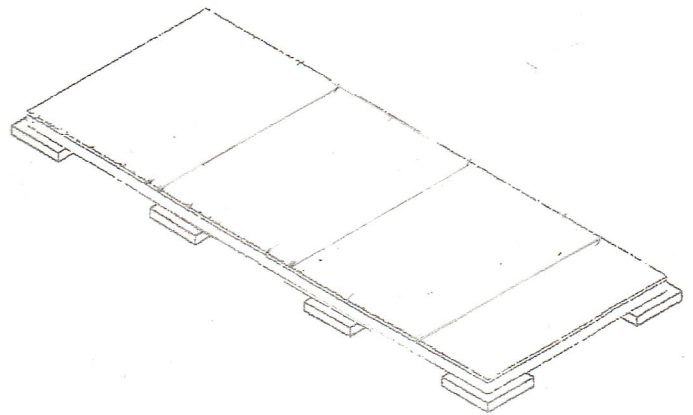
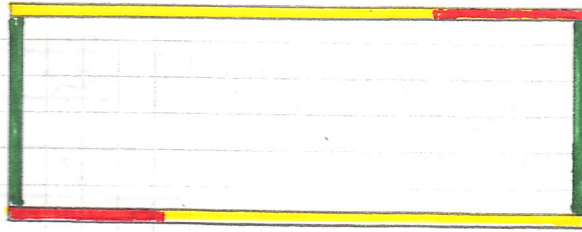

Fig F-4



PART #	DESCRIPTION	DIMENSIONS (where app.)	# OF PCS	CODE
WALL PARTS				
P-2334G	headers	2 x 3 x 34 1/2	2	not shown
P-2346G	headers	2 x 3 x 46 1/2	2	not shown
BW-002	wall panels	34 1/2 x 74 3/4	2	BW-002
BW-003	wall panels	46 1/2 x 74 3/4	2	BW-003
WW-003	window wall	46 1/2 x 74 3/4	1	WW-003
DW-005	door frame	46 1/2 x 74 3/4	1	DW-005



PART #	DESCRIPTION	DIMENSIONS (where app.)	# OF PCS	CODE
TOP PLATES				
P-2329G	top plates	2 x 3 x 29 1/2	2	
P-2371K	top plates	2 x 3 x 71 3/4	2	
P-2326C	top plates	2 x 3 x 26 1/4	2	

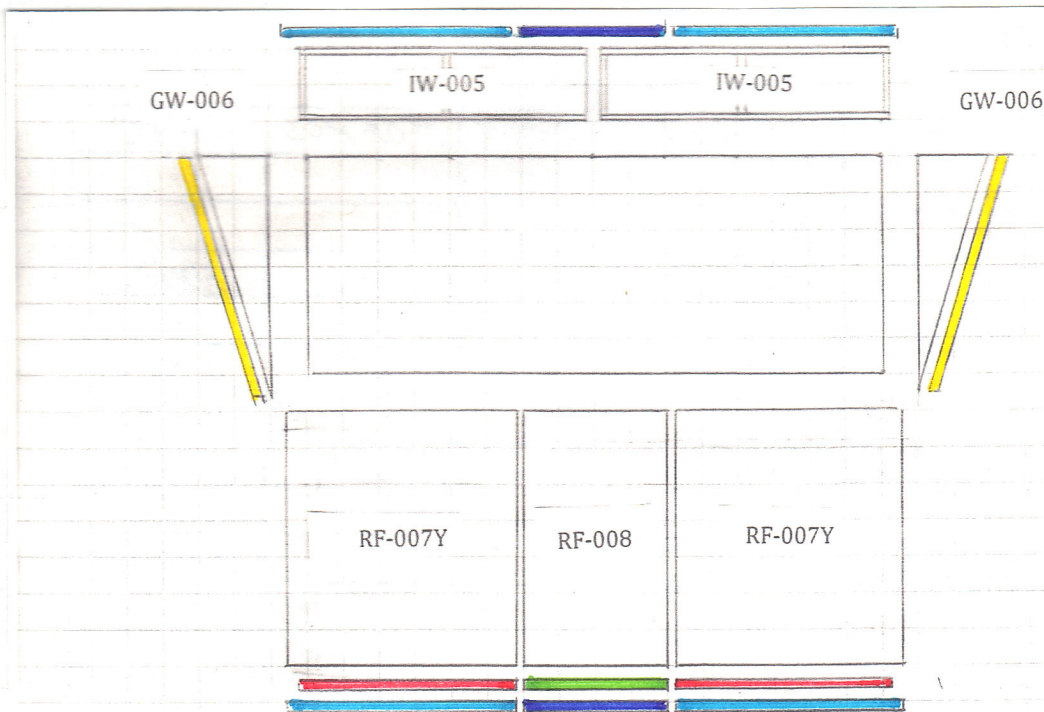



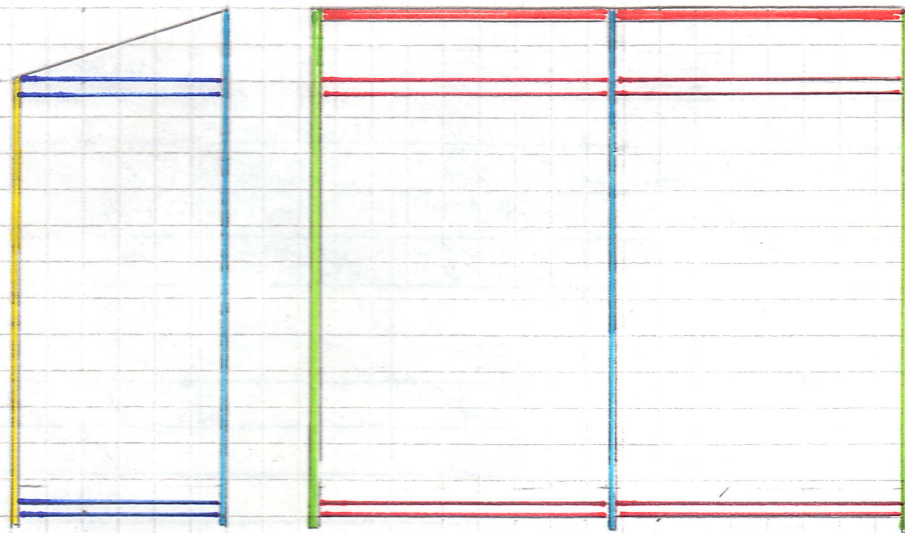



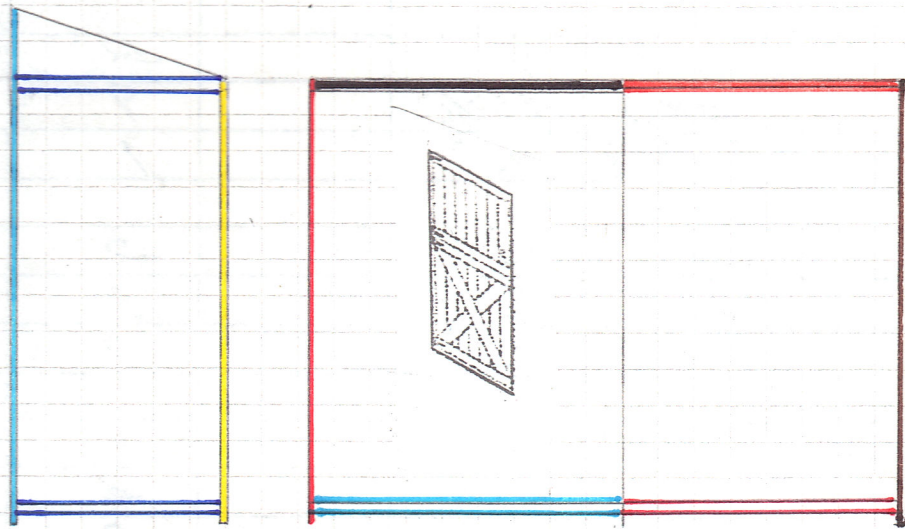

PART #	DESCRIPTION	DIMENSIONS (where app.)	# OF PCS	CODE
ROOF PARTS AND PANELS				
RF-007Y	roof panels (left & right)	42 3/4 x 40	2	RF-007Y
RF-008	roof panel	24 x 40	1	RF-008
GW-006	gable panel (left & right)	10 x 39 /12	2	GW-006
IW-005	infill wall	46 1/2 x 7	2	IW-005
P-G437	soffit	1/2 x 4 x 37	2	
P-G424	soffit	1/2 x 4 x 24	1	
P-1442	fascia	1 x 4 x 42	4	
P-1424	fascia	1 x 4 x 24	2	
P-1442Yg	gable fascia(left & right)	1 x 4 x 42	2	



1 22



PART #	DESCRIPTION	DIMENSIONS (where app.)	# OF PCS	CODE
TRIM PARTS				
P-13C87G	trim	1 x 3 1/4 x 87 1/2	2	
P-13C79C	trim	1 x 3 1/4 x 79 1/4	1	
P-11K79C	trim	1 x 1 3/4 x 79 1/4	1	
P-1287G	trim	1 x 2 x 87 1/2	3	
P-1280G	trim	1 x 2 x 80 1/2	2	
P-B-G645	skirting	1/2 x 6 x 45	5	
P-B-G633	skirting	1/2 x 6 x 33	4	
P-B-G3G45	skirting	1/2 x 4 x 45	3	
P-14B48	bottom door trim	1 x 4 1/8 x 48	1	
P-12FULL48	top door trim	1 x 2Full x 48	1	