



contacta ■

Portable InfoLoop™

Setting up

Place portable InfoLoop™ Unit on the desk or counter top between the hearing aid wearer and the member of staff so that:

- Rear of unit, with in-built microphone, Faces staff
- Front of unit, with 'T' position label, Faces hearing aid wearer

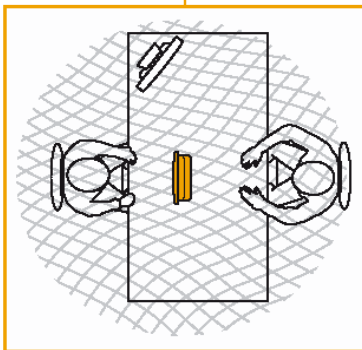

Portable InfoLoop™

Switching 'ON'

Slide the switch on the left hand side of the rear of the Portable InfoLoop™ Unit to the 'ON' position. See below:

If LED flashes red:

- Battery is low and requires charging



To Charge

- Plug in power supply unit
- Connect flexible lead socket marked 'PWR' on the rear of the portable InfoLoop™ Unit
- Unit may be charged while the system is in operation
- When charging, the LED will illuminate constant red

Note: The unit will operate approximately 8 hours on fully charged batteries

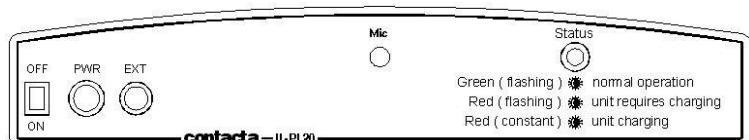



Using the system

During normal operation the LED will flash green when conversation is taking place. This indicates that the system is working.

If hearing aid user does not pick up clear signal:

- Adjust position of portable InfoLoop™ Unit on desk or counter to achieve optimum performance for hearing aid user
- Draw hearing aid user's attention to the induction loop sign, to check their device is in the 'T' position
- Ask the hearing aid user to check the volume setting on their device



Using External Boundary Microphone

If a number of people are speaking together

- Insert microphone plug into socket marked 'EXT' on rear of Portable InfoLoop™ Unit
- Position microphone on desk top in front of those speaking

If several people are speaking together, for example in a round table discussion, place the external microphone in a central position.

Contacta, Inc.
332 E. Lakewood Blvd.
Holland, MI 49424

Phone (616) 392-3400
Email richard@contactainc.com



Technical support

Contacta offers comprehensive technical support for all its systems, including:

- Advice via telephone helpline, fax or email
- On-site visit by a Contacta field service engineer
- Detailed installation and service manuals supplied with every system

Customers have access to continuous help and support, technical or administrative, through the Contacta helpline.

Contacta Inc Helpline

Email
Support@contactainc.com

Telephone: (616) 392-3400

General recommendations

- Put Portable InfoLoop™ Unit on charge after each Use, so that it is fully charged and ready for the Next occasion. alternatively plug the charger in at all times if the unit is to be used on a semi-Permanent basis.
- If not used regularly, the unit should be left on charge constantly so that it is ready when needed.