

- Ⓝ NO Brukerveiledning
- Ⓝ GB Installation manual
- Ⓝ SE Installationsanvisning
- Ⓝ FI Asennusohje
- Ⓝ DE Montageanleitung
- Ⓝ FR Manuel d'installation

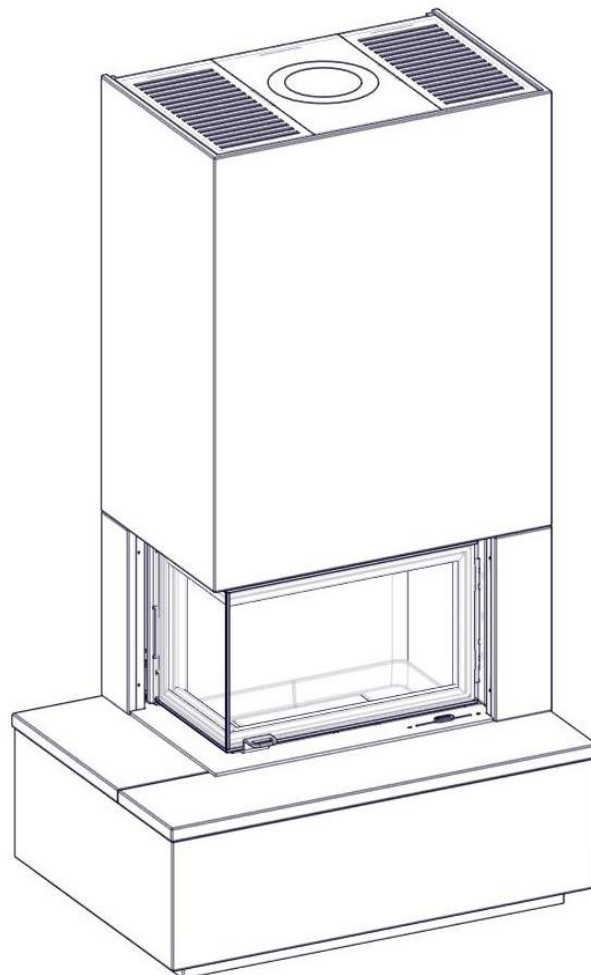

Monaco A Low Base L + Bench

Art.no: FP-MON03-40L
Last updated: 13.02.2020
Test Report No: RRF 40 17 4637

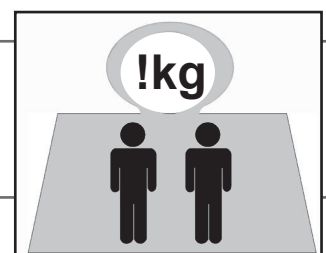

FIG 1 b

Monaco A Low Base + Bench / Q-34 AL = mm

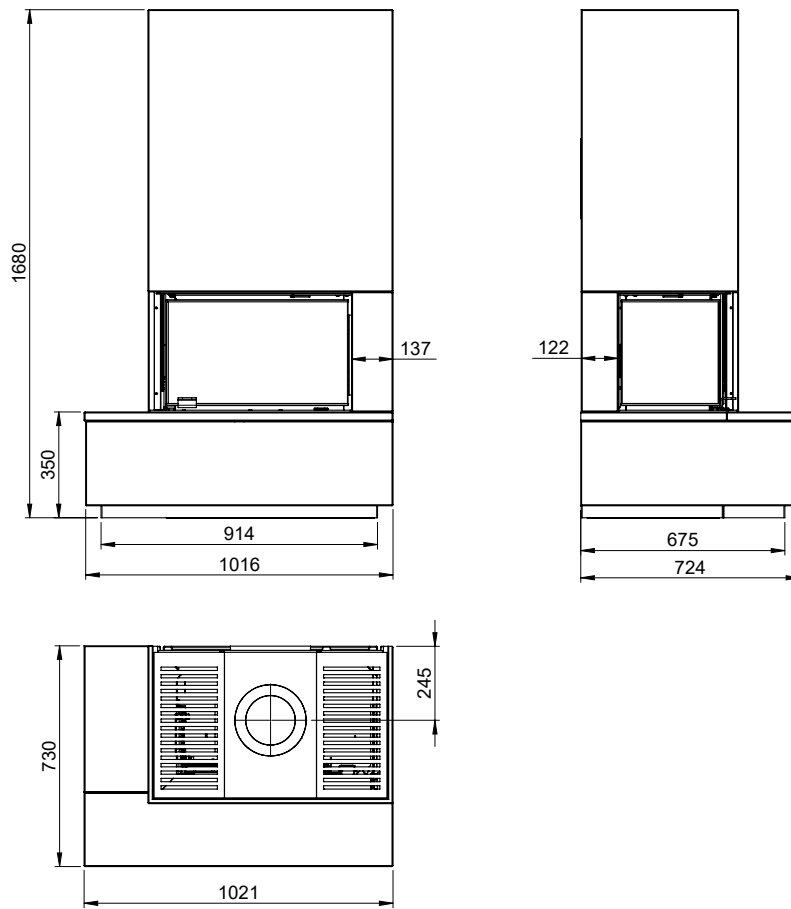

FIG 1 c

Monaco A Low Base + Bench / Q-34 AL = Chimney / AIR mm

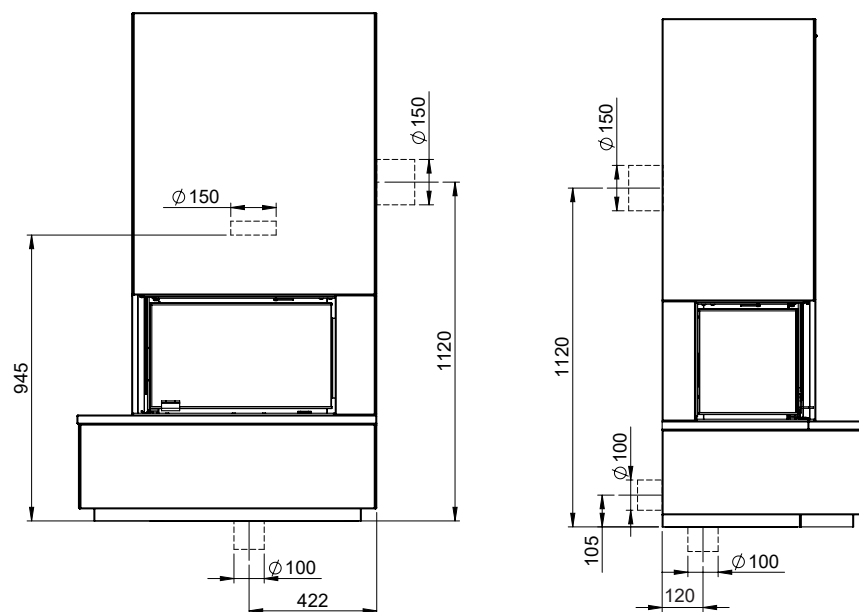
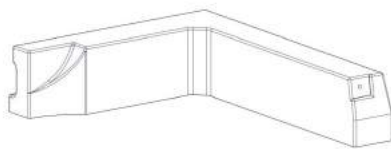
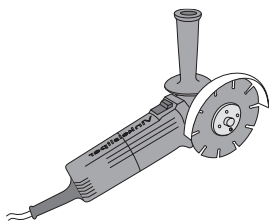
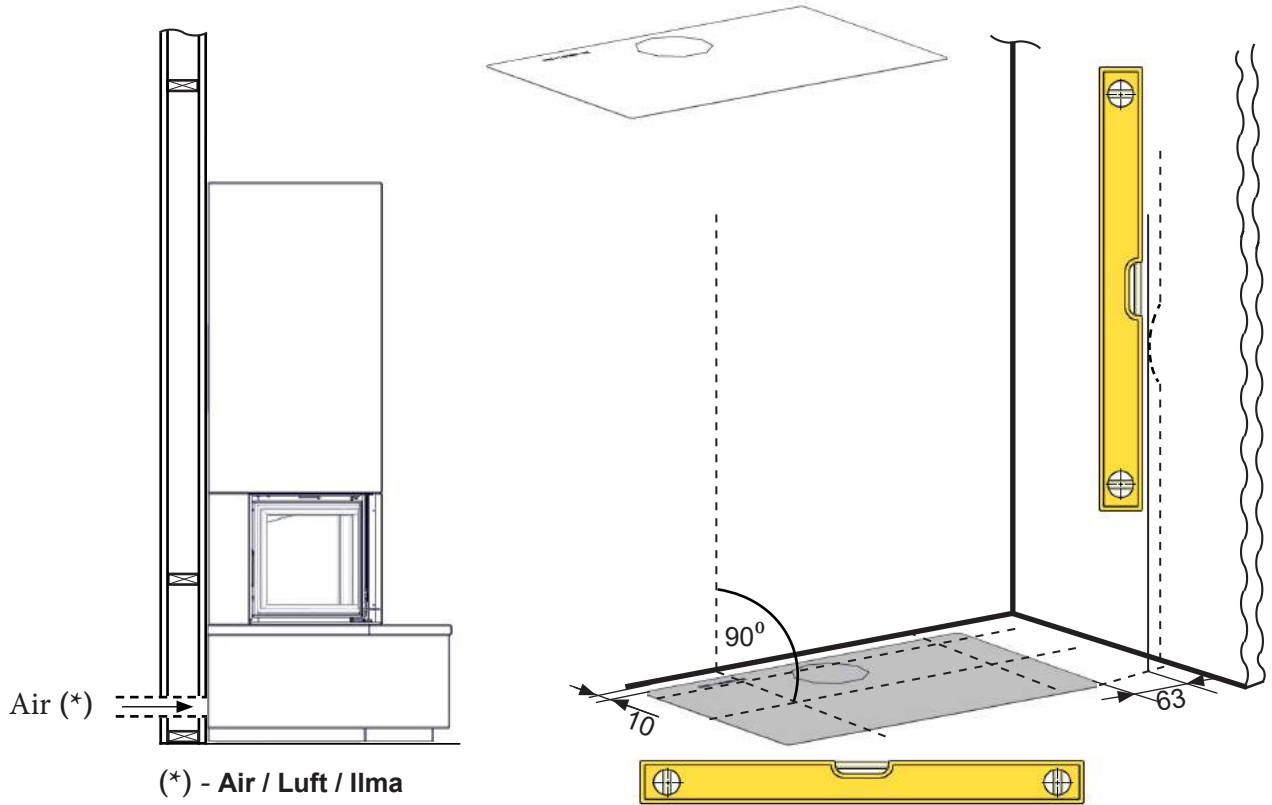

FIG 3 A

Monaco A Low Base_Q-34 AL + Bench

22-MON01-200 x1



CO-MON03-01R

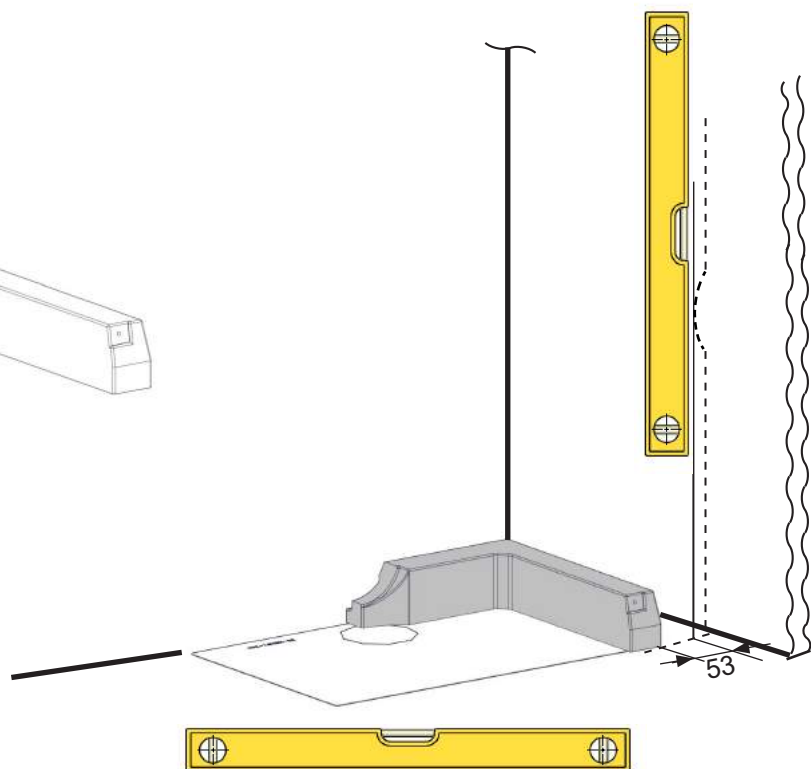

FIG 3 B

Monaco A Low Base_Q-34 AL + Bench

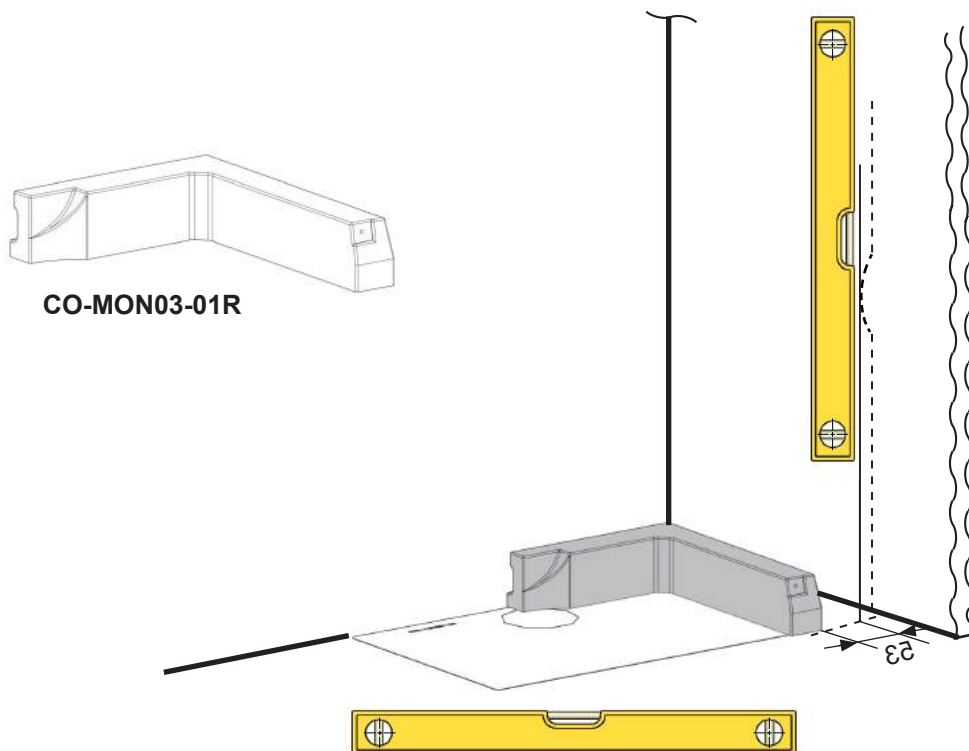
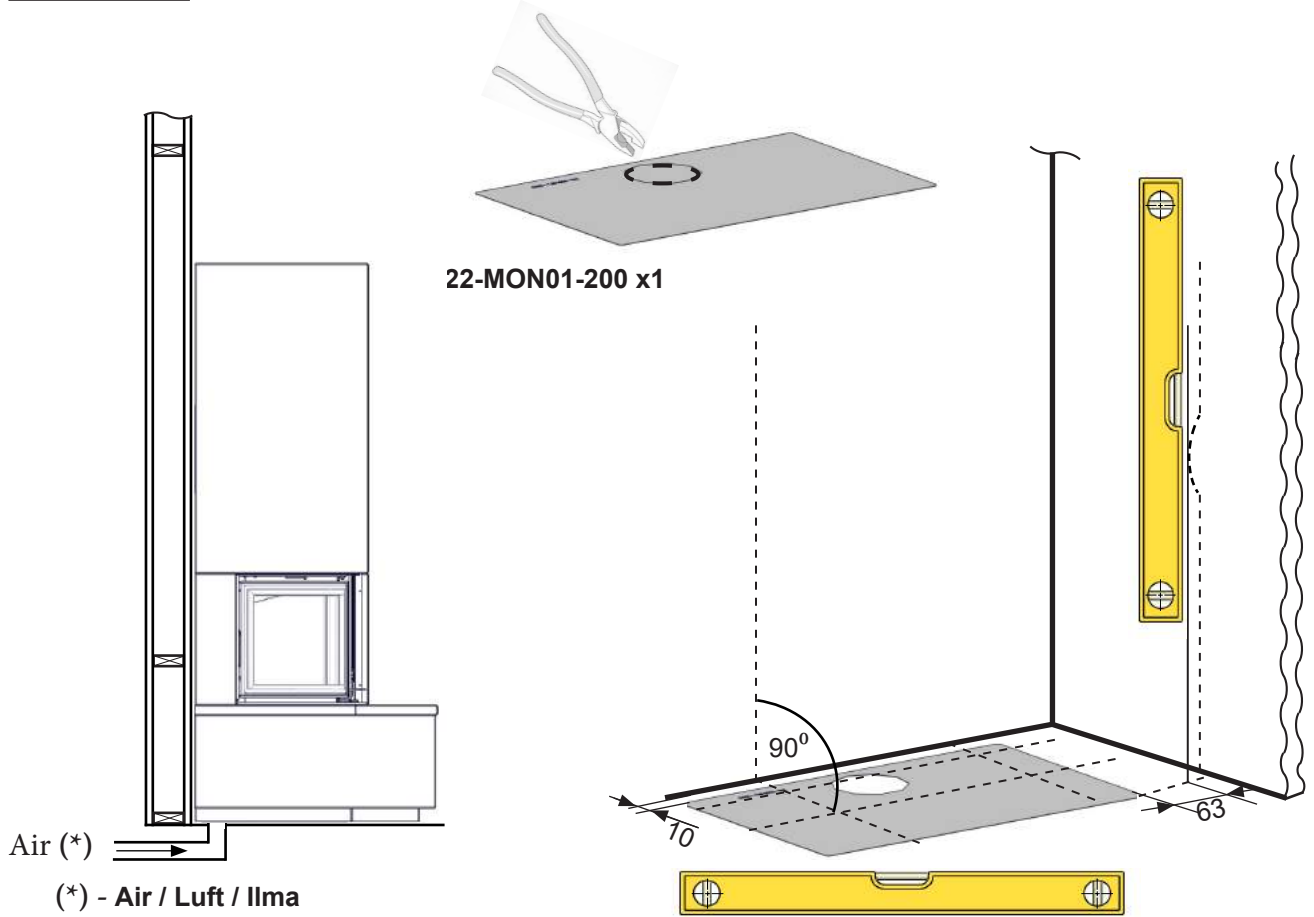

FIG 4 Monaco A Low Base_Q-34 AL + Bench

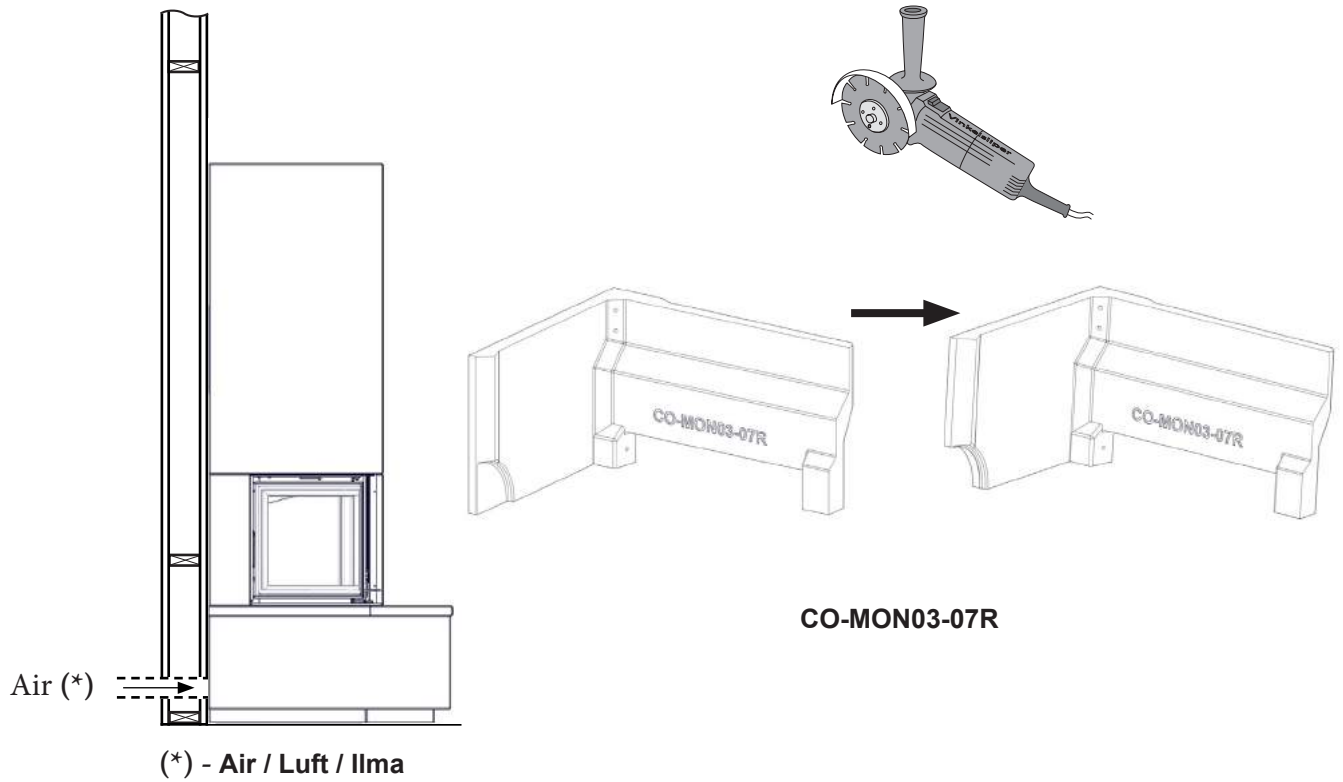

FIG 4 a Monaco A Low Base_Q-34 AL + Bench

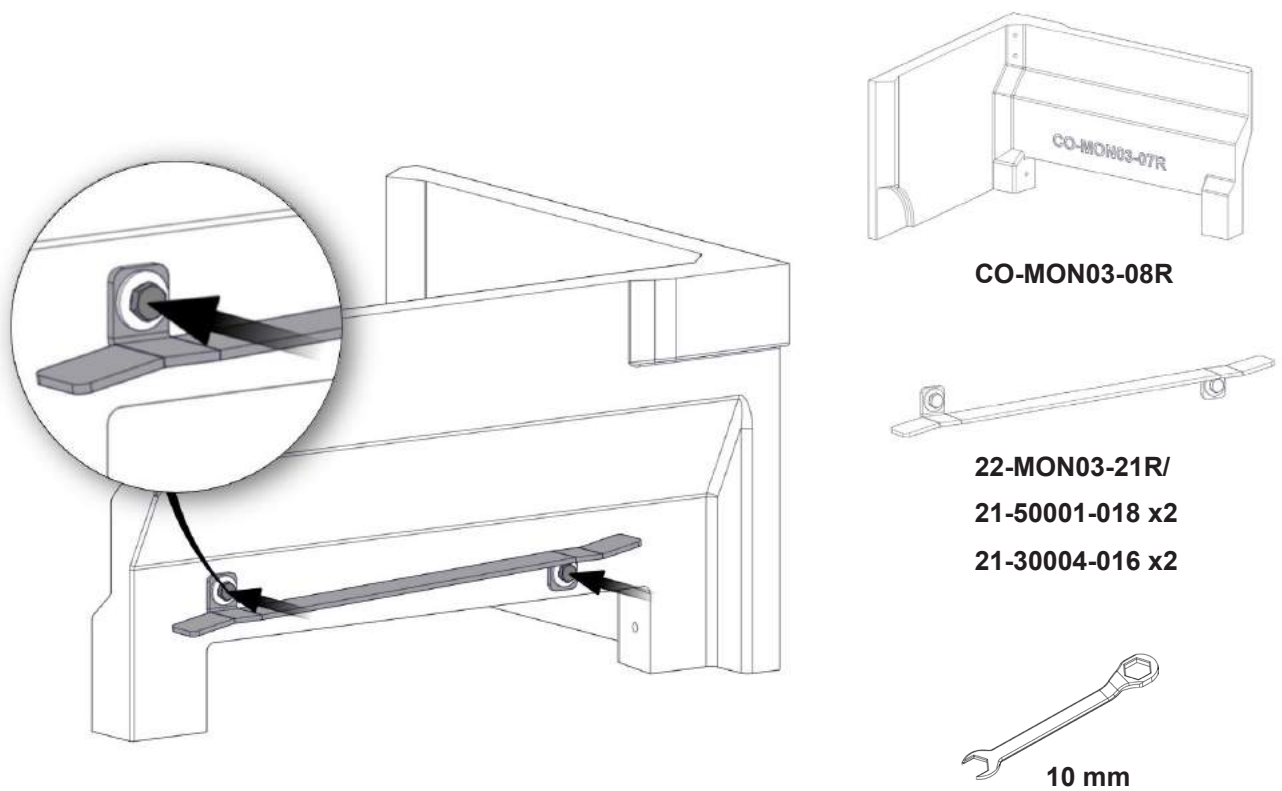
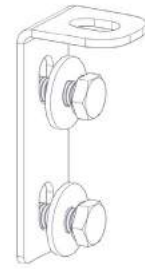
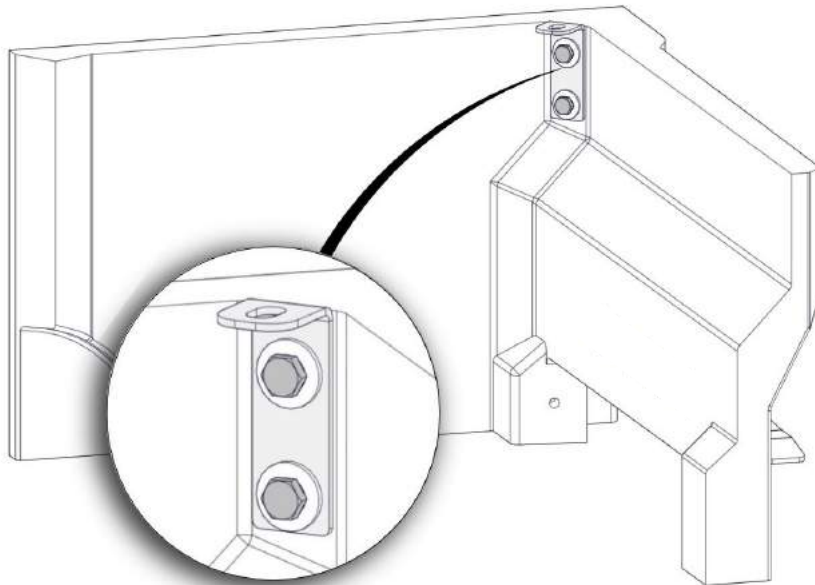
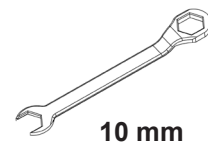

FIG 4 b Monaco A Low Base_Q-34 AL + Bench



- 22-MON03-030**
- 21-50001-018 x2**
- 21-30004-016 x2**



10 mm

FIG 5 Monaco A Low Base_Q-34 AL + Bench

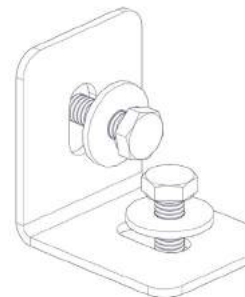
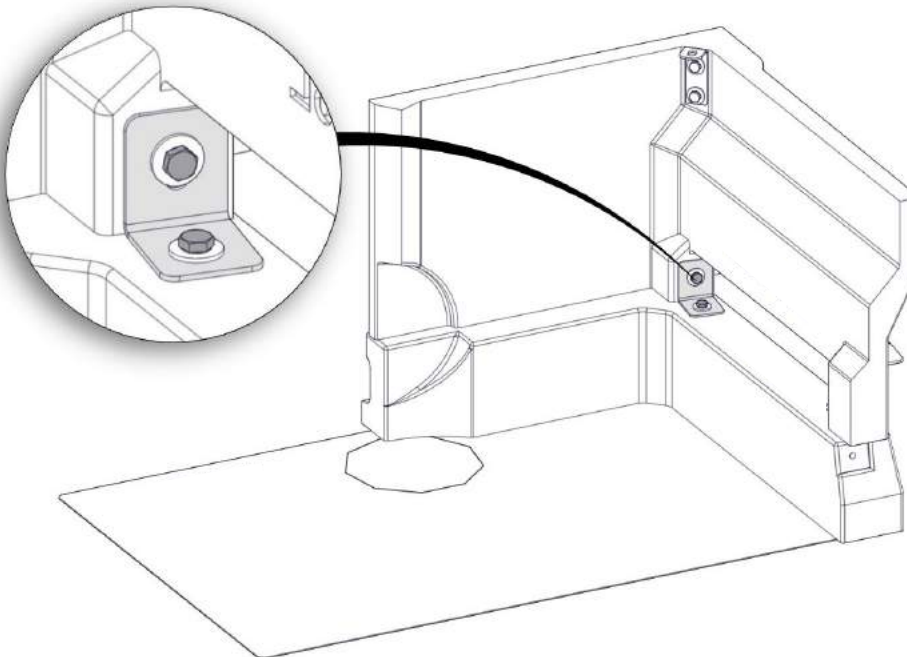

- 22-MON03-020**
- 21-50001-018 x2**
- 21-30004-016 x2**

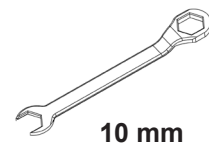

10 mm

FIG 6 Monaco A Low Base_Q-34 AL + Bench

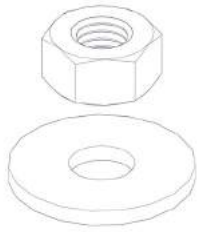

- 22-04032-006
- 21-00000-006 x2
- 21-50001-018 x2

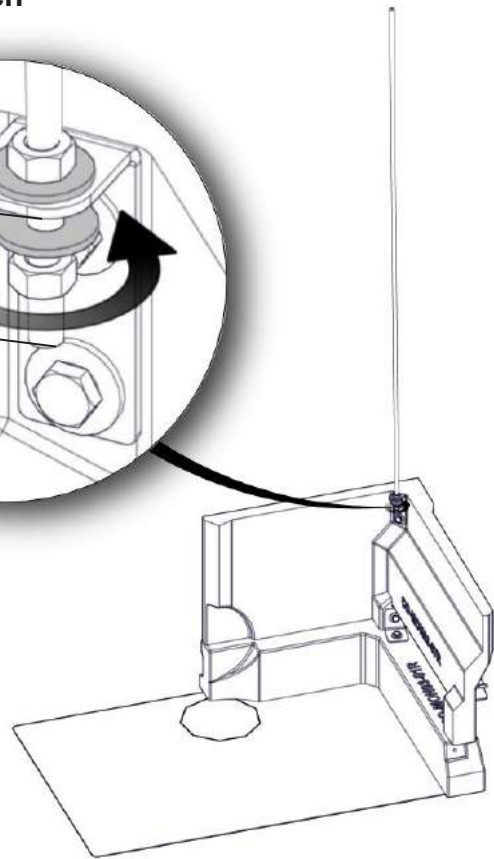
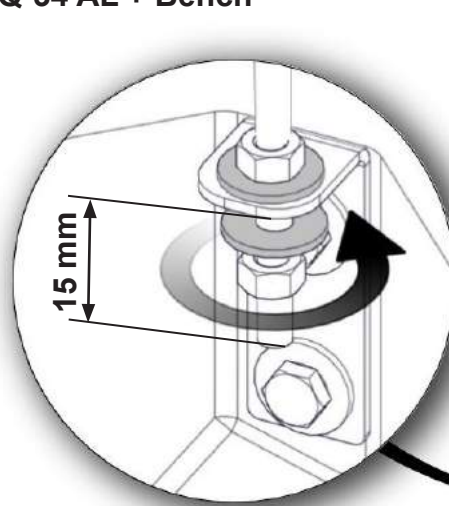
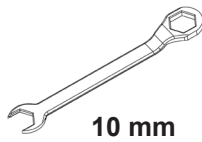

FIG 7 Monaco A Low Base_Q-34 AL + Bench

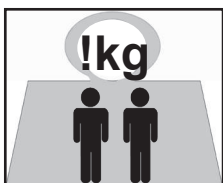
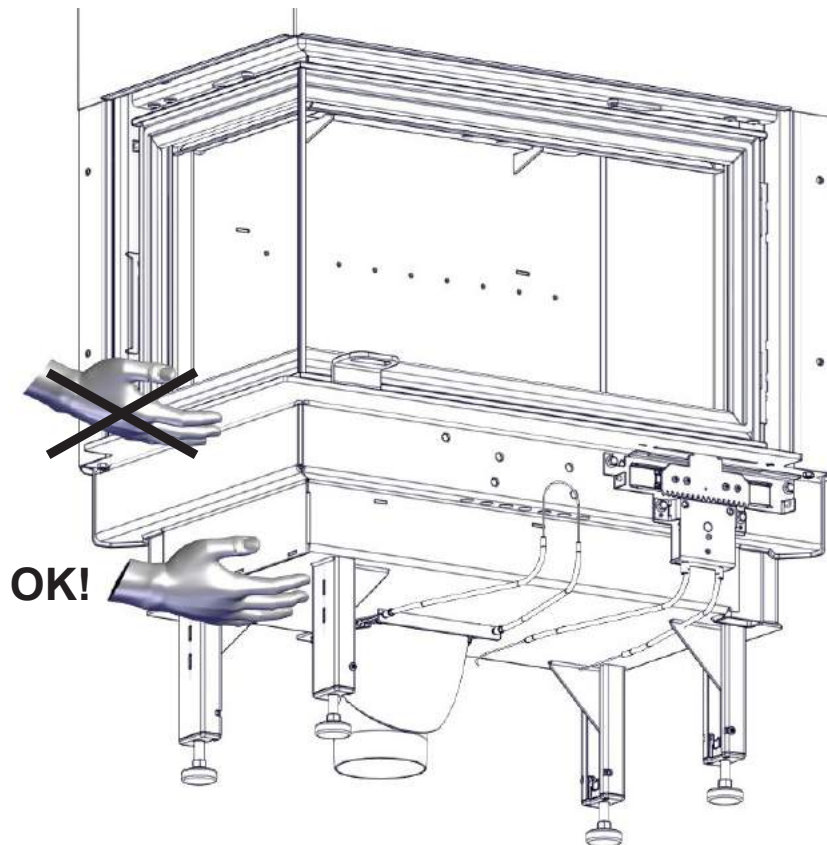

FIG 7 a

Monaco A Low Base_Q-34 AL + Bench

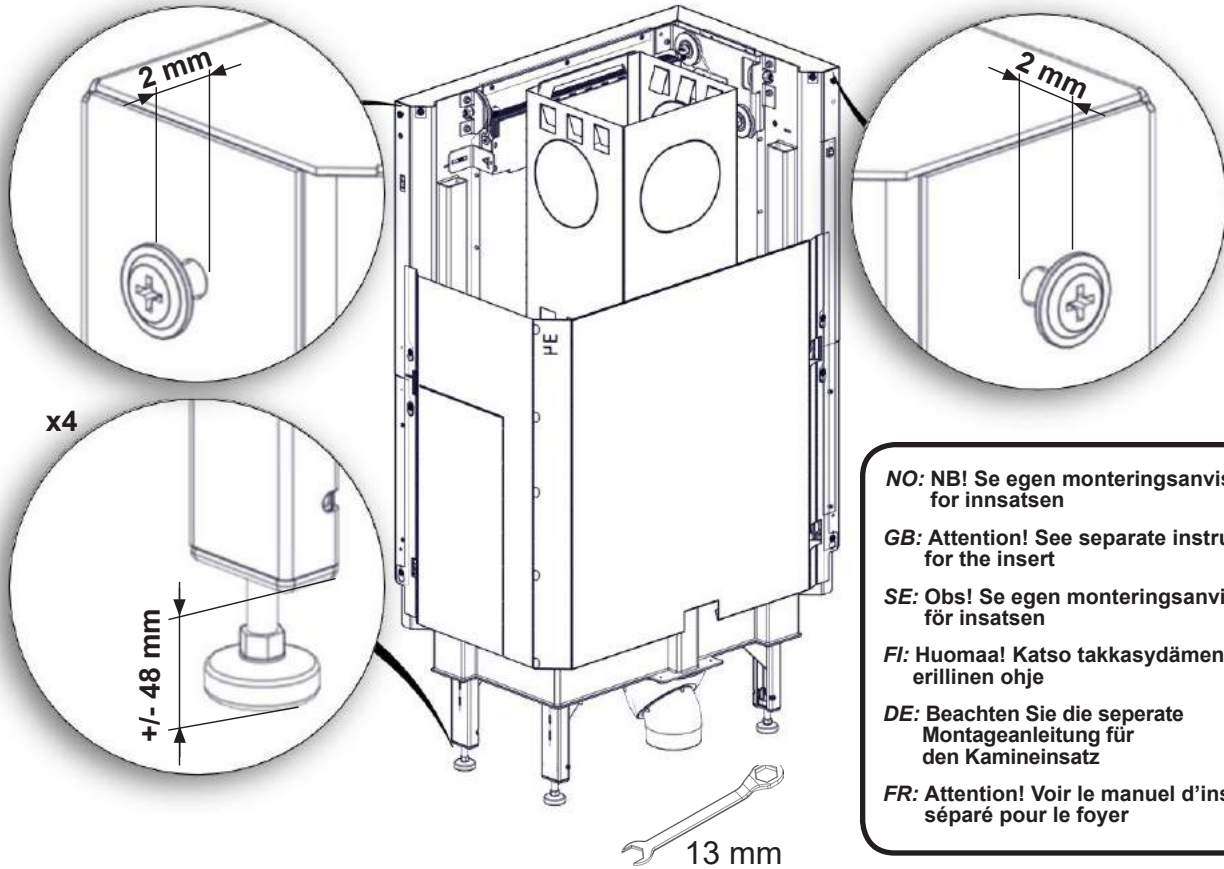

FIG 7 b

Monaco A Low Base_Q-34 AL + Bench

Side- og baktilkobling / Side and rear connection
 Siv- tai takaliitäntä / Anslutning från sidan eller bakifrån
 Raccordement arrière ou latérale / Anschluss hinten/ seitlich

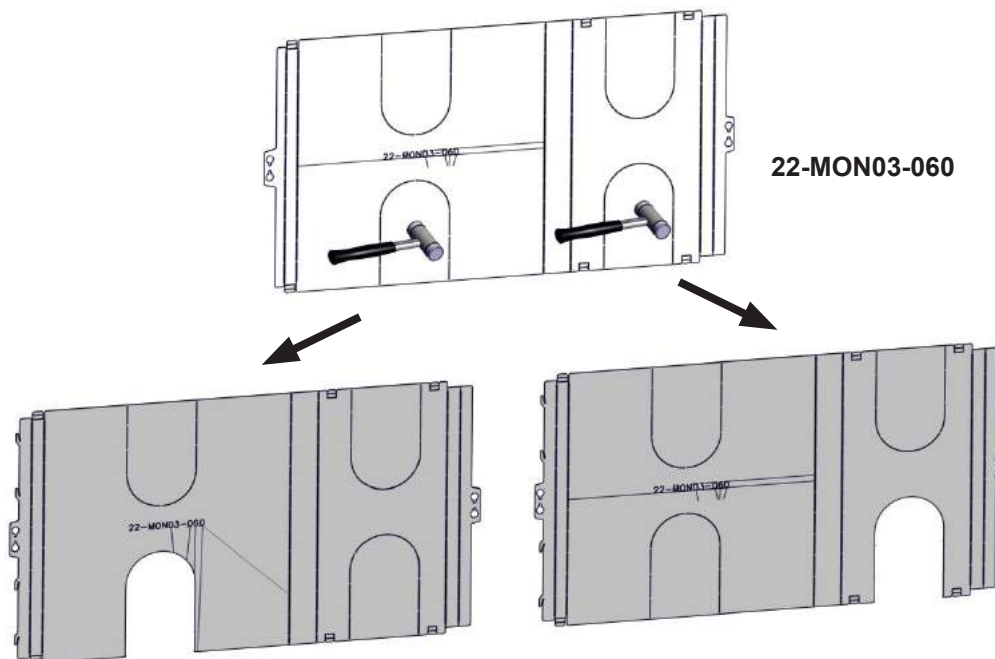

FIG 7 c

Monaco A Low Base_Q-34 AL + Bench

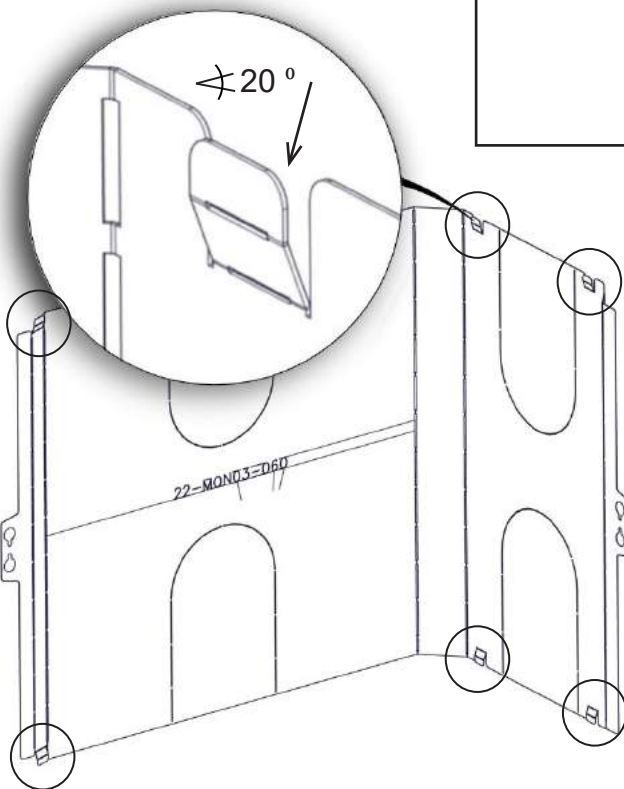
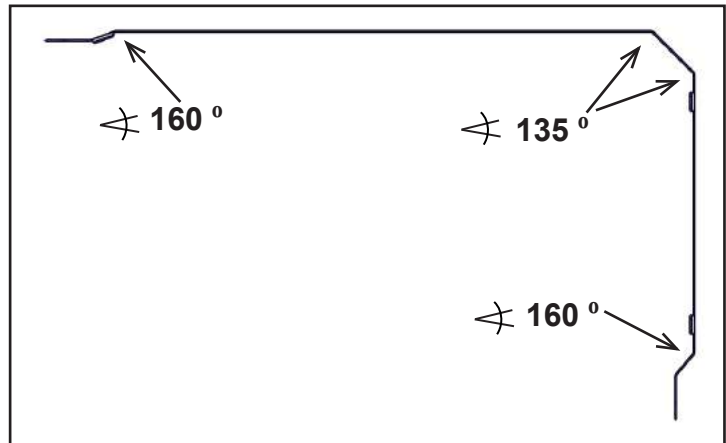
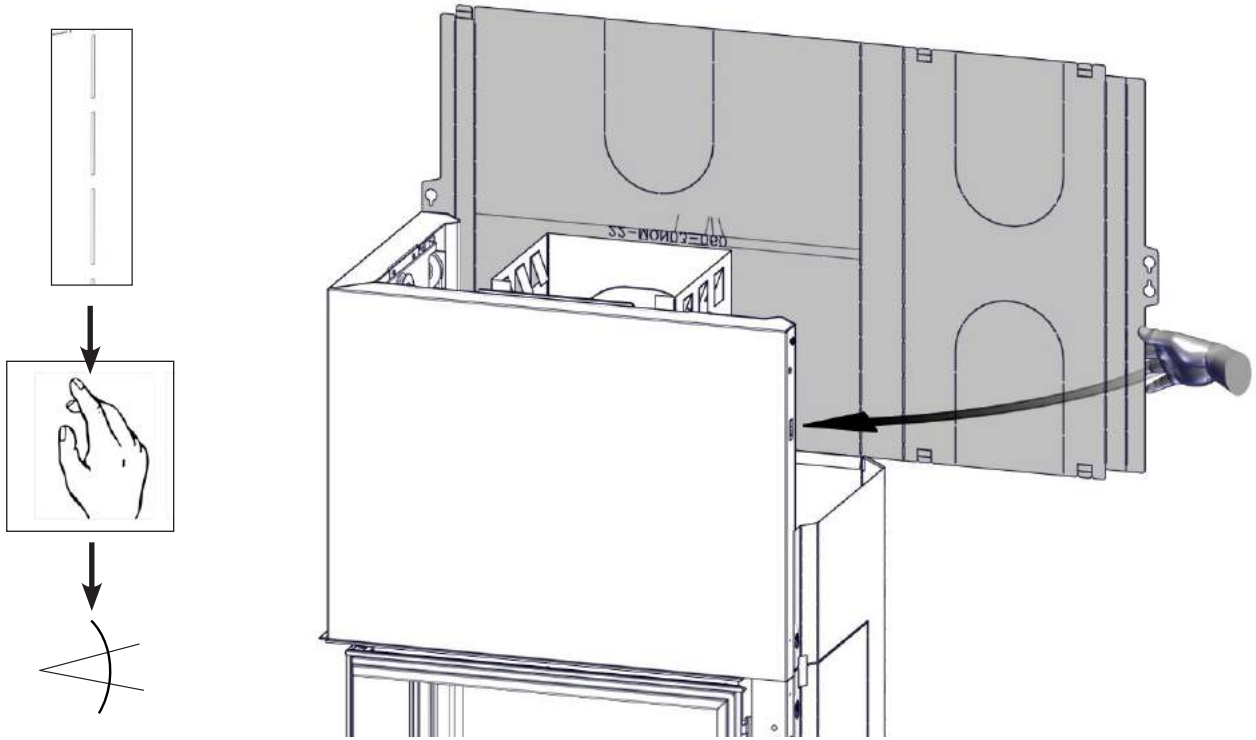

FIG 7 d Monaco A Low Base_Q-34 AL + Bench

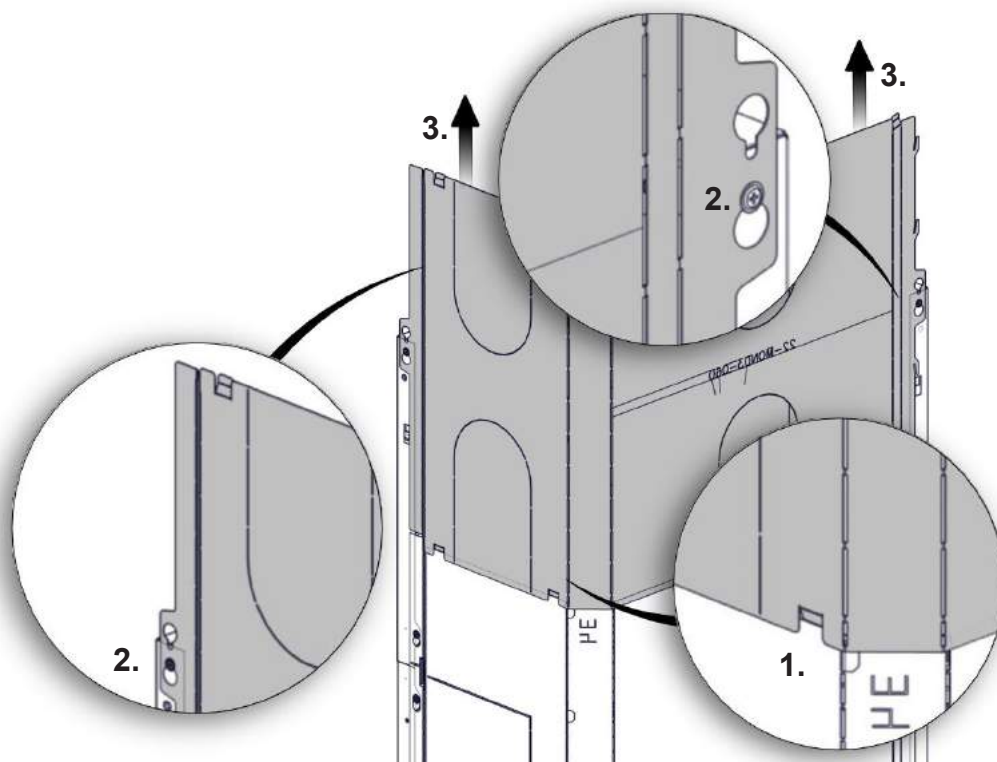

FIG 7 e Monaco A Low Base_Q-34 AL + Bench

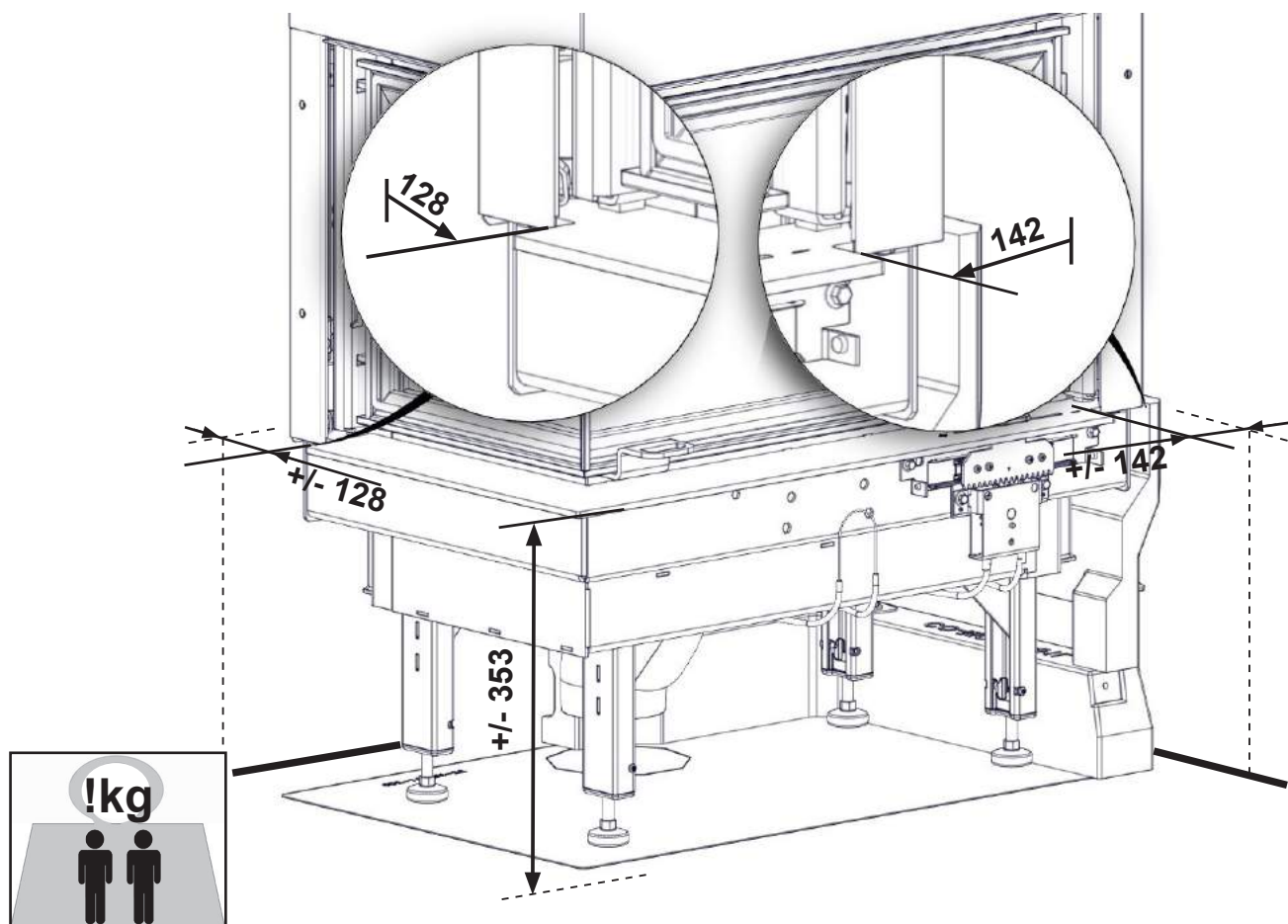

FIG 8 A

Monaco A Low Base_Q-34 AL + Bench

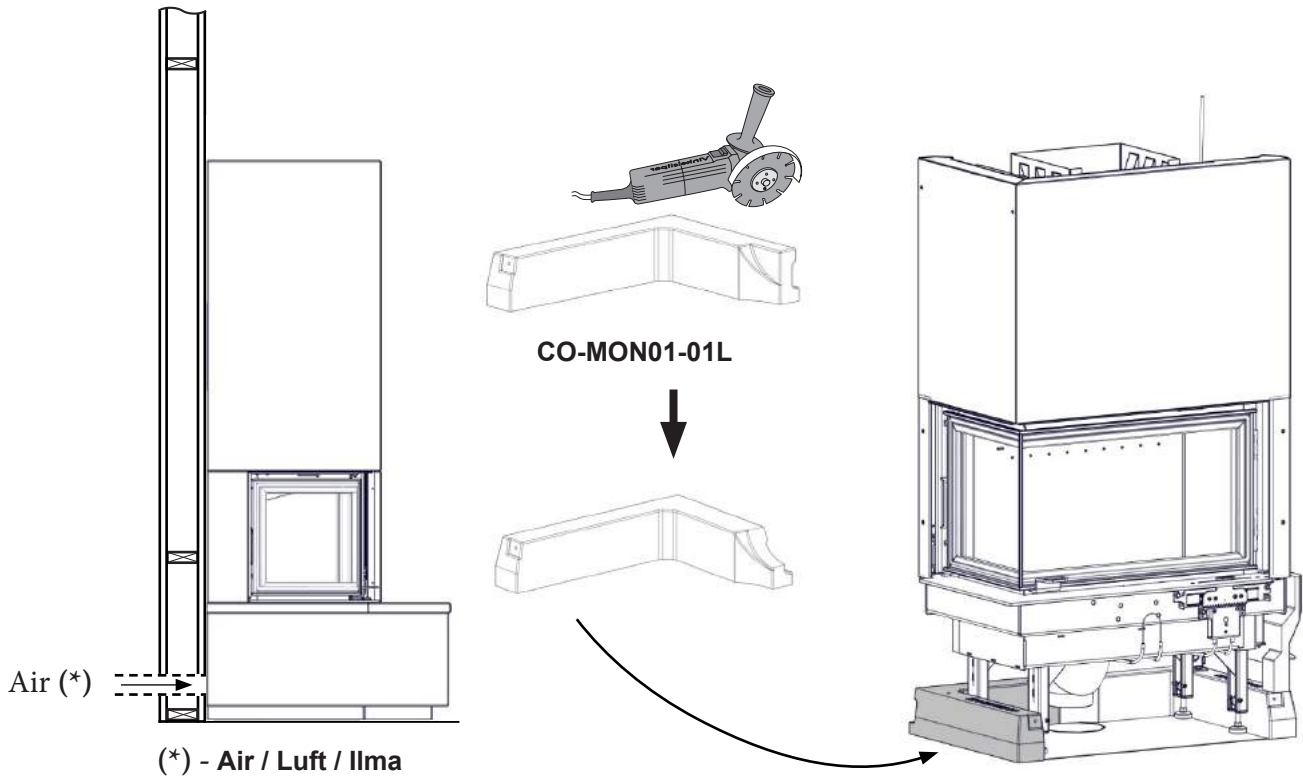

FIG 8 B

Monaco A Low Base_Q-34 AL + Bench

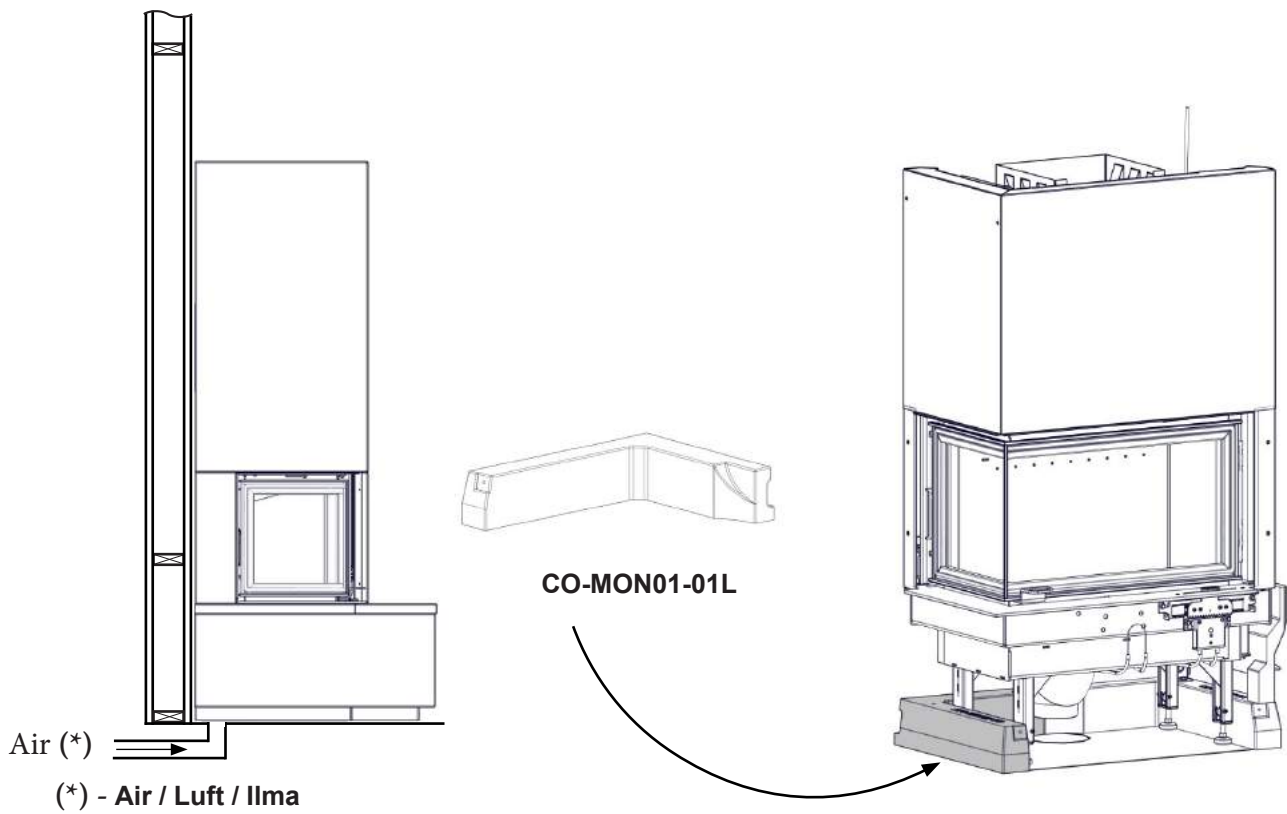

FIG 9

Monaco A Low Base_Q-34 AL + Bench

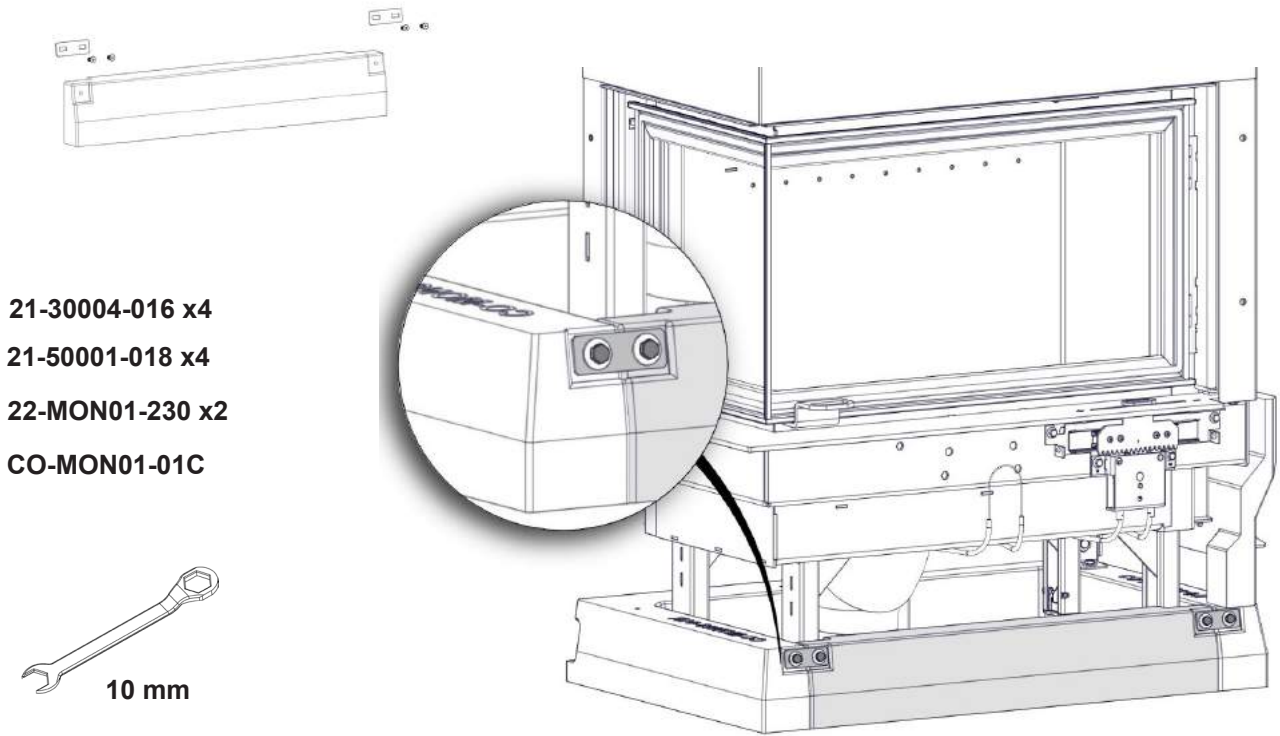

FIG 10

Monaco A Low Base_Q-34 AL + Bench

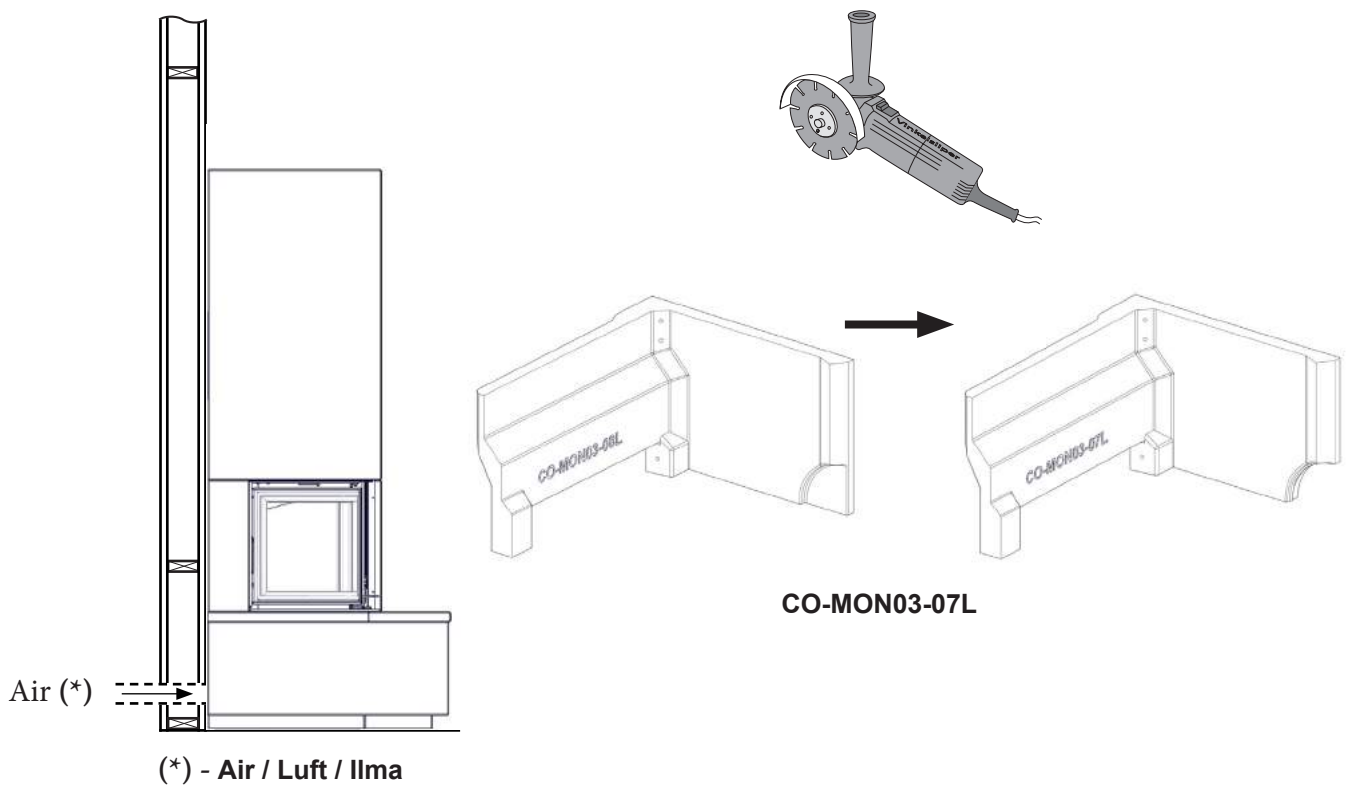

FIG 10 a

Monaco A Low base_Q-34 AL + Bench

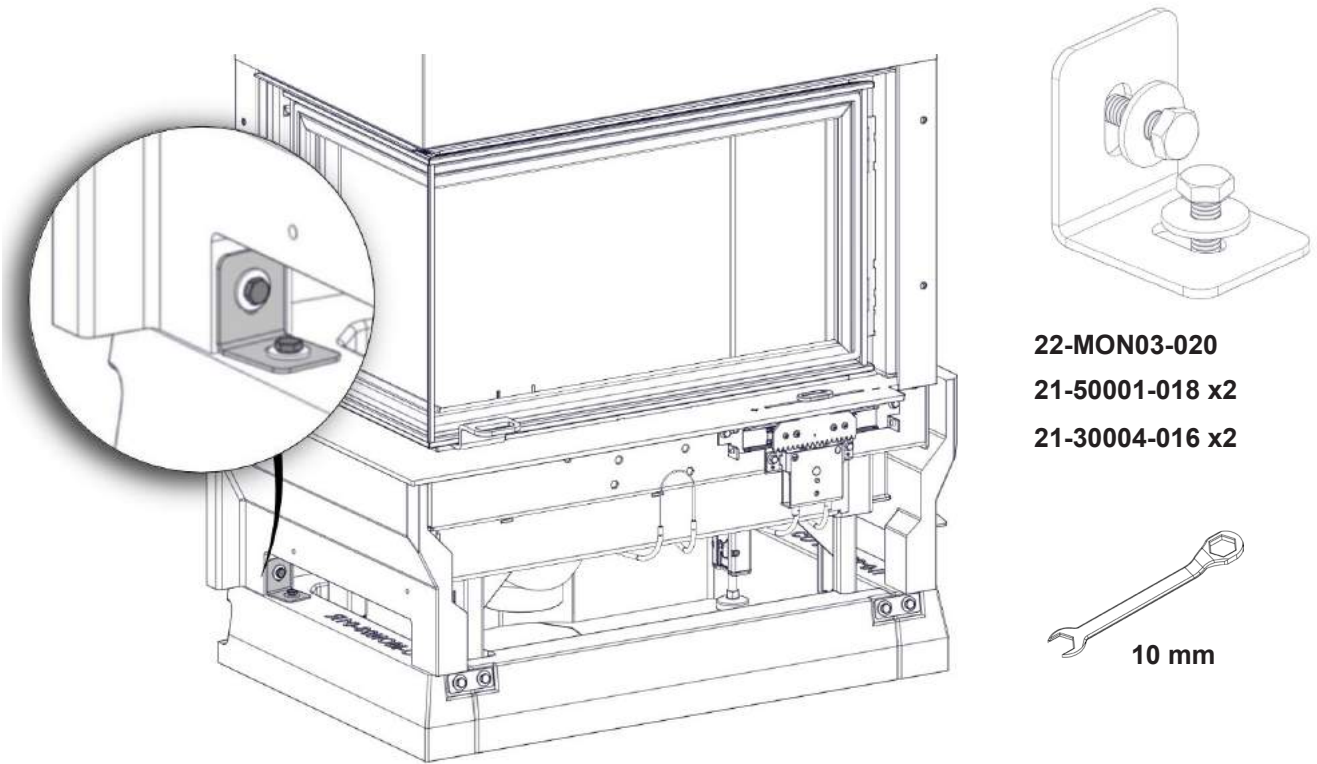

FIG 11

Monaco A Low base_Q-34 AL + Bench

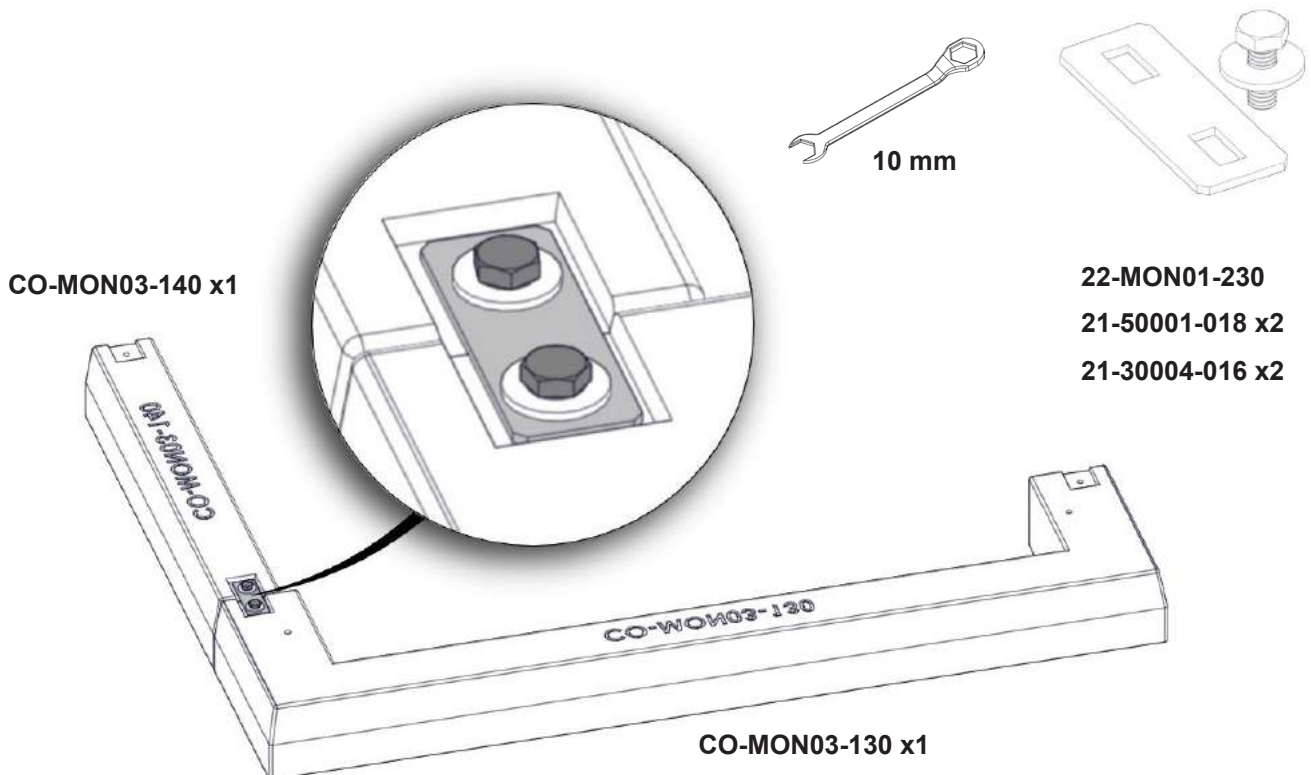

FIG 12

Monaco A Low base_Q-34 AL + Bench

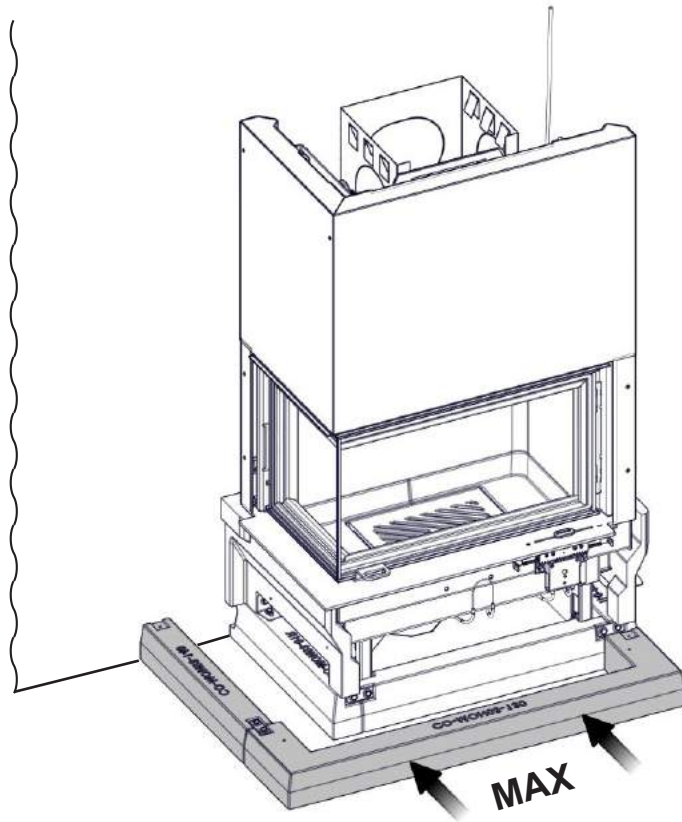
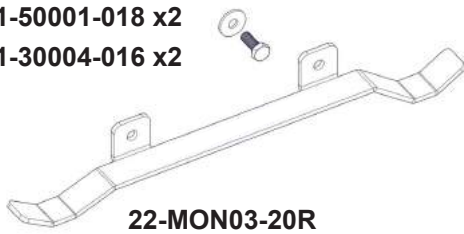

FIG 13

Monaco A Low base_Q-34 AL + Bench

21-50001-018 x2

21-30004-016 x2



22-MON03-20R

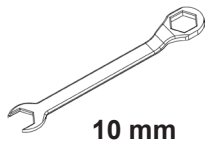

10 mm

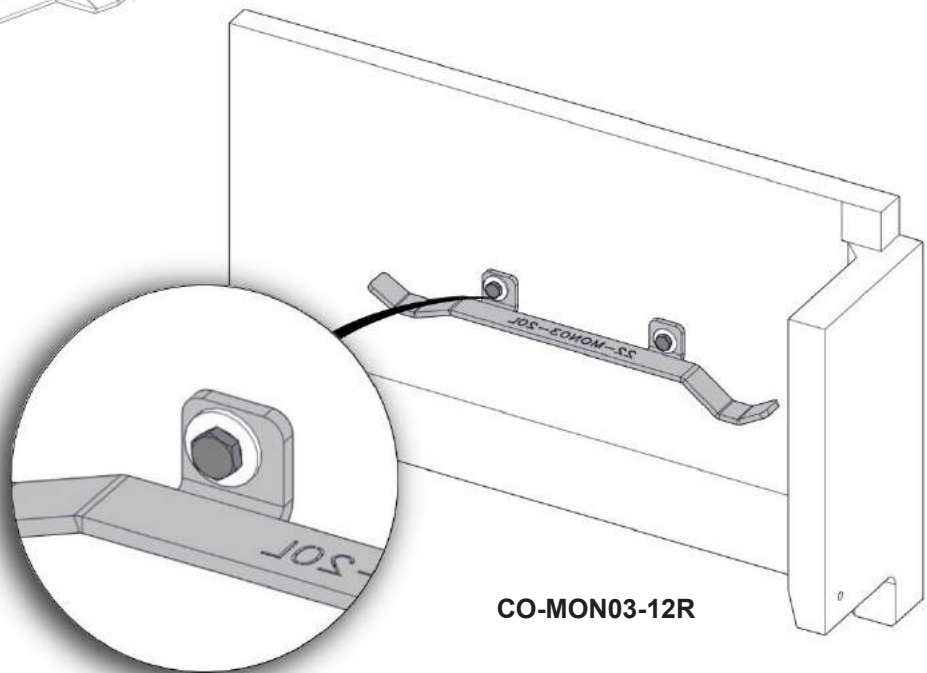

CO-MON03-12R

FIG 13 a

Monaco A Low base_Q-34 AL + Bench

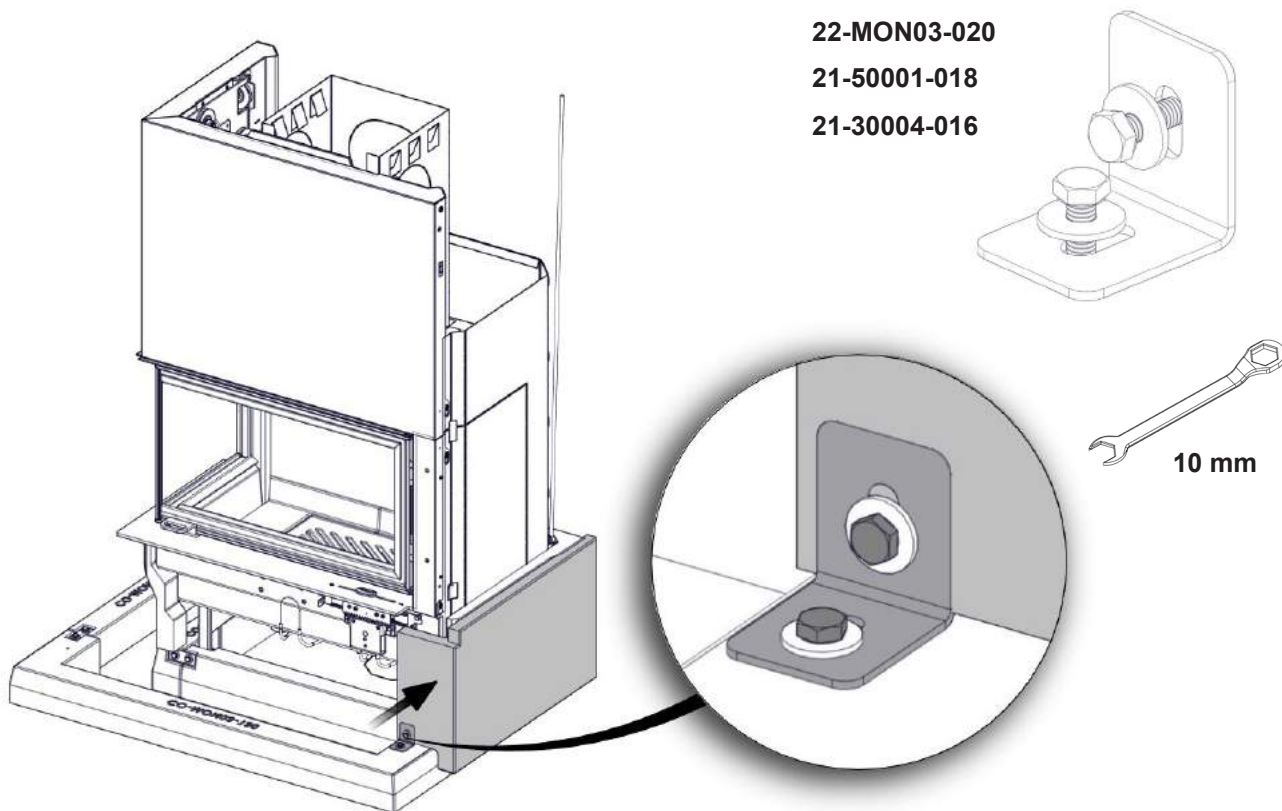

FIG 14

Monaco A Low base_Q-34 AL + Bench

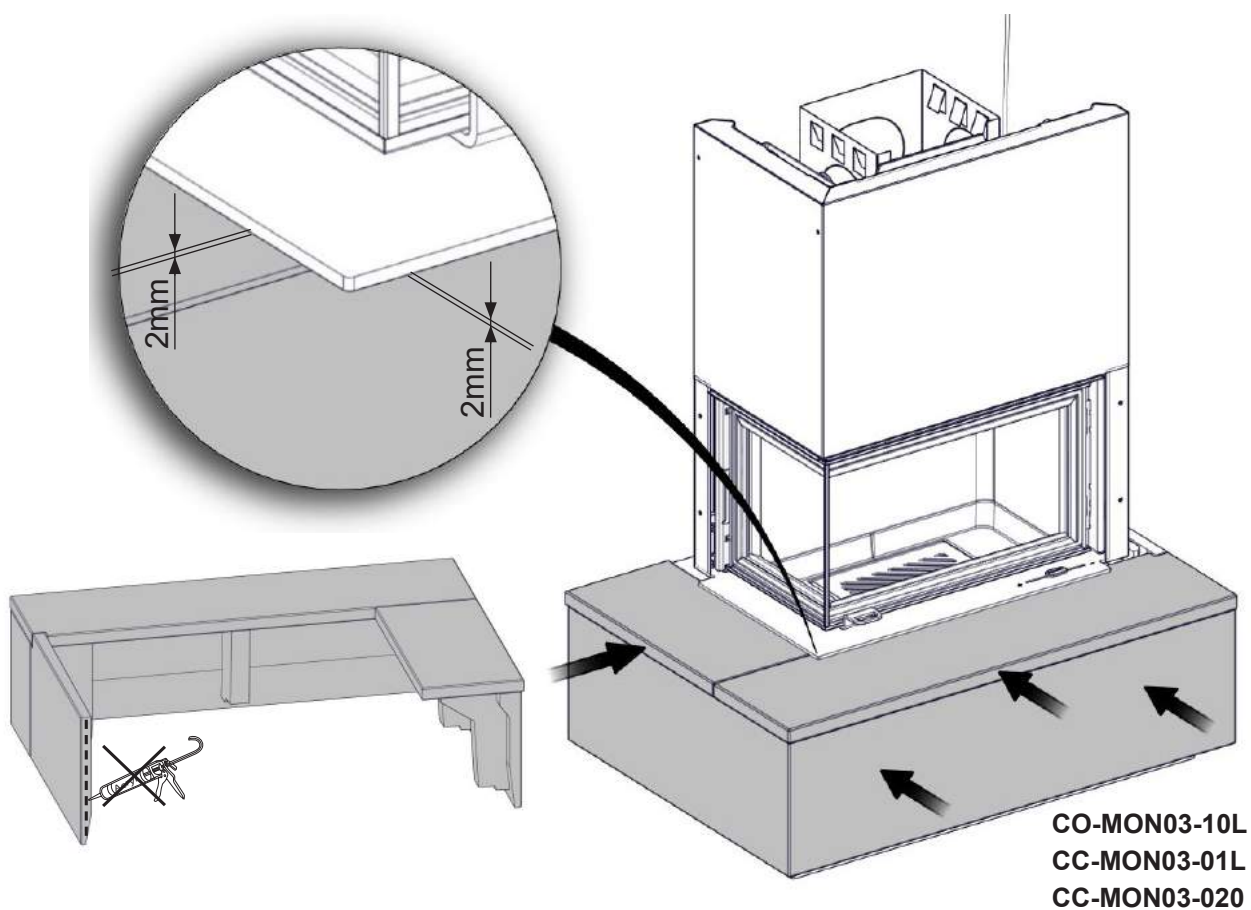

FIG 15

Monaco A Low Base_Q-34 AL + Bench

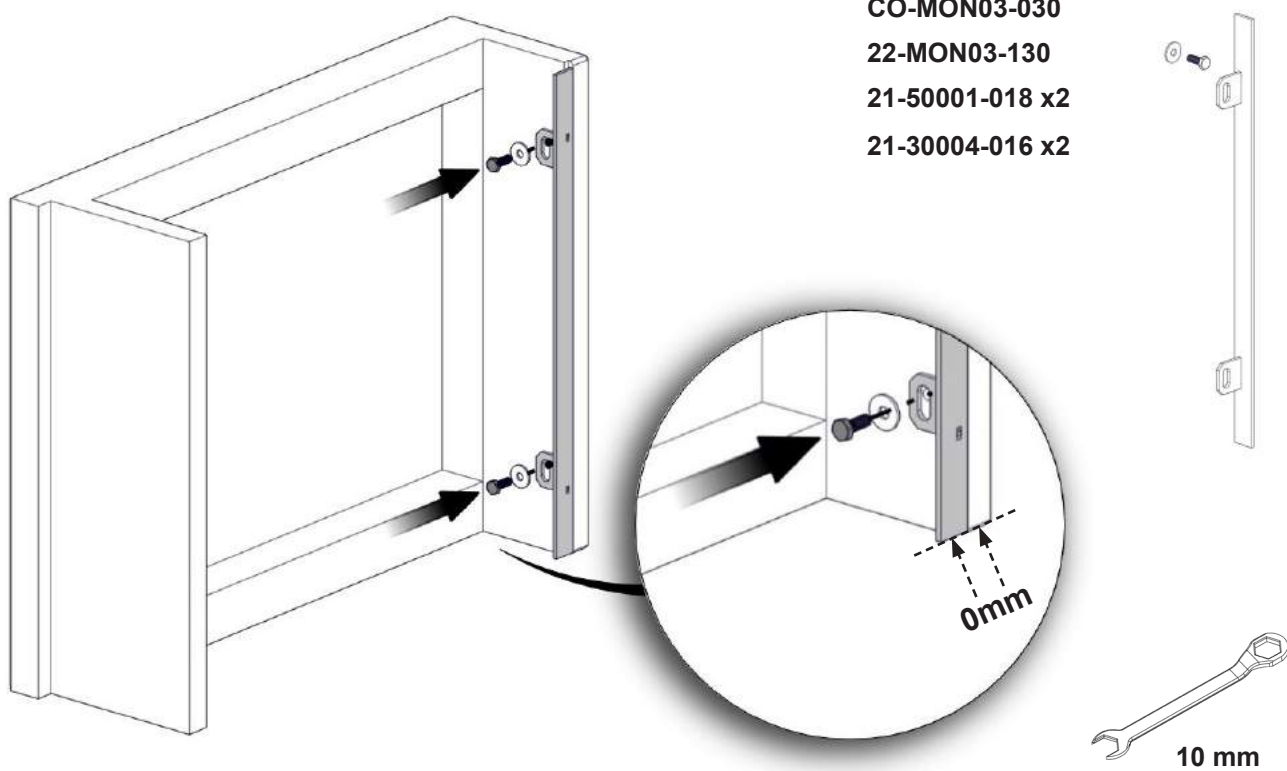

FIG 15 a

Monaco A Low Base_Q-34 AL + Bench

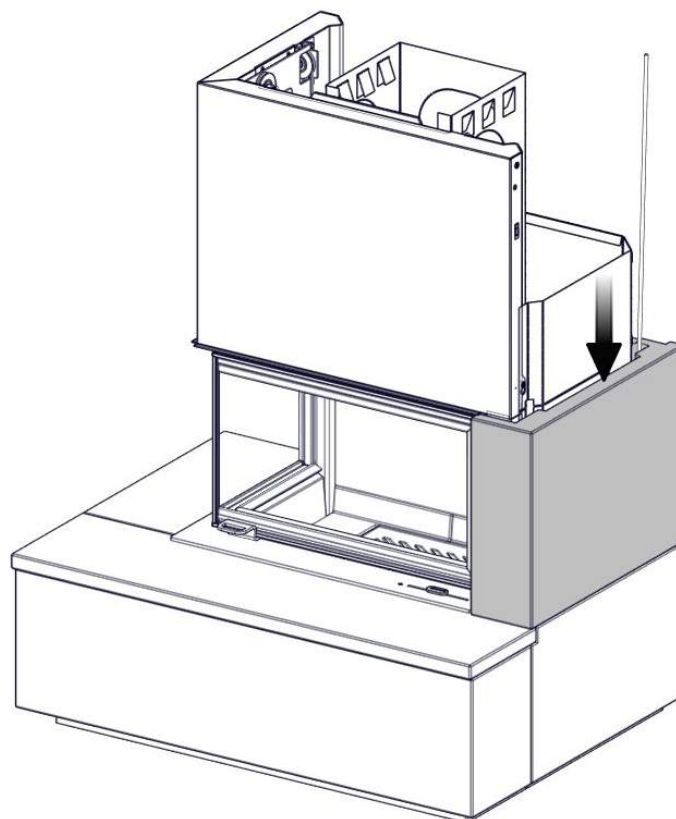

FIG 16

Monaco A Low Base_Q-34 AL + Bench

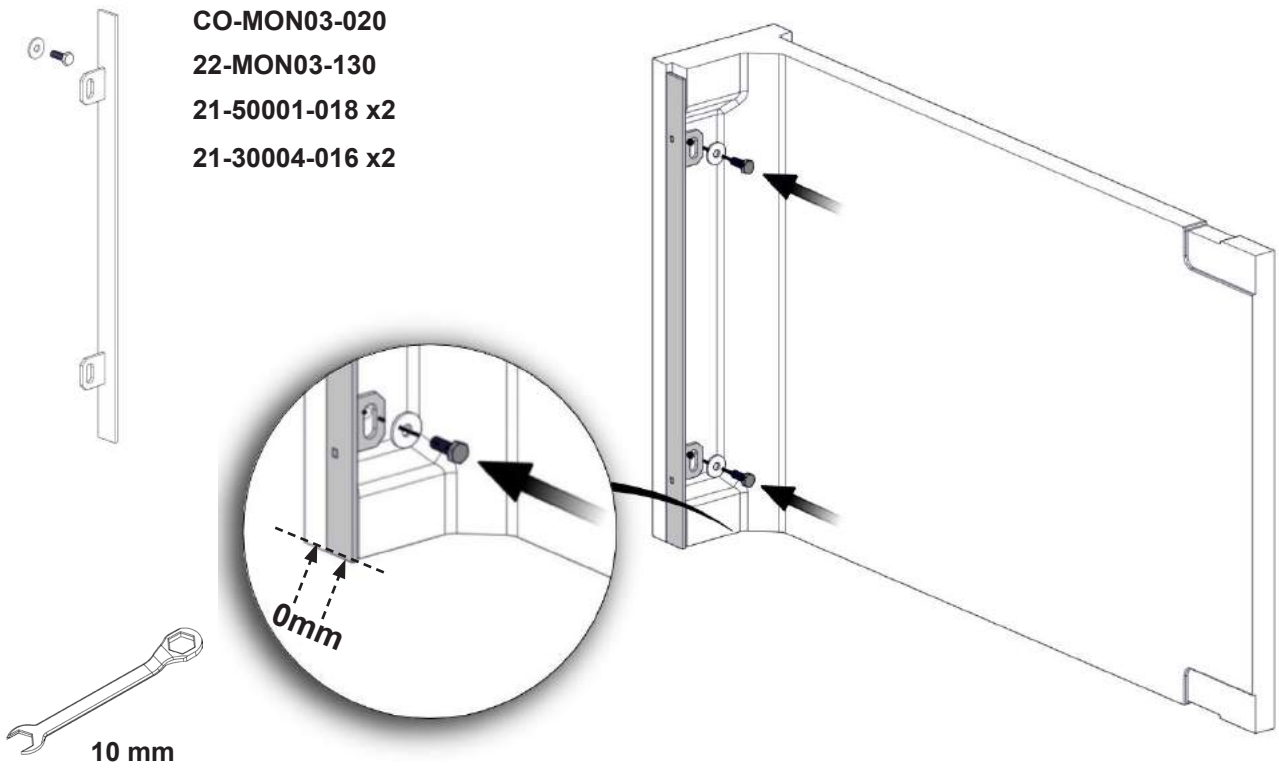

FIG 16 a

Monaco A Low Base_Q-34 AL + Bench

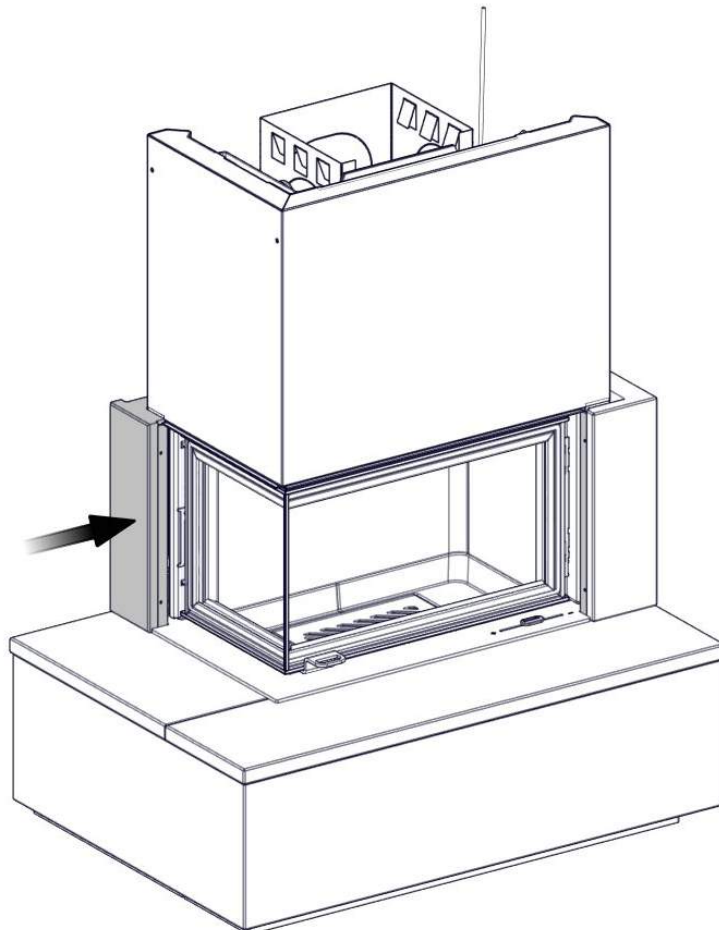

FIG 17

Monaco A Low base_Q-34 AL + Bench

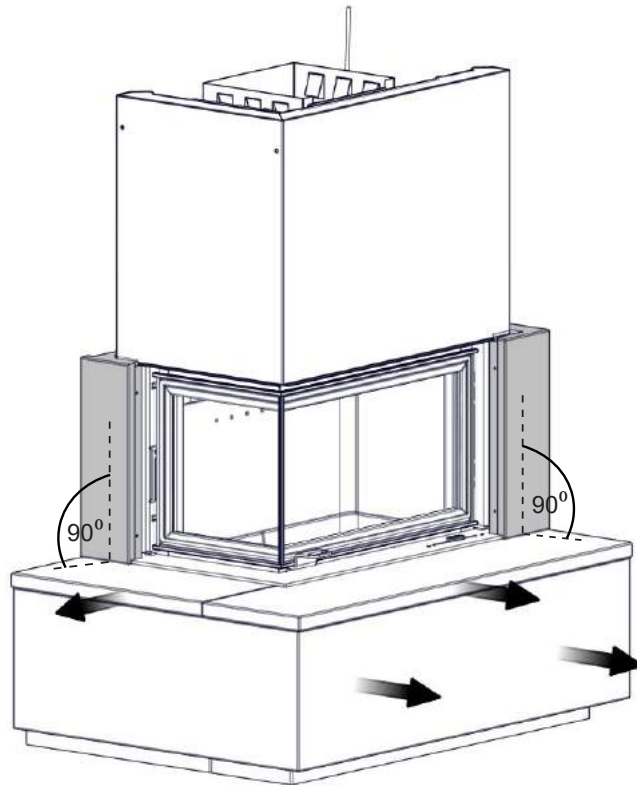

FIG 18

Monaco A Low Base_Q-34 AL + Bench

NO: Om ildstedet skal monteres med tilslutning av pipe bak og tilluftskanal, lag hull etter perforeringen i platen. Betongring monteres mellom platen og veggen, se fig. 18 a. Fest betongringen med akryl.



GB: If you utilize either rear chimney connection and external air duct make a hole cutting out perforation and place a concrete ring between the plate and adjacent wall - see FIG 18a . Use acrylic glue to join the ring with the plate.



SE: Om kaminen ska monteras med bakre rökgasanslutning och luftkanal, måste hål tas upp i bakplattan (hålmarkering finns i plattan) och en betongring monteras mellan plattan och väggen, se fig. 18 a. Fäst betongringen i plattan med akryllim.



FI: Jos käytät takaseinän savuputkiliitäntää ja ulkoa tulevaa palamisilmakanavaa, poista esileikattu pyöreä levy ja asenna betonirengas levyn ja seinän väliin - katso kuva 18 a. Kiinnitä rengas levyyn akryyliimalla.



DE: Wenn Sie den hinteren Schornsteinanschluss oder einen Außenluftkanal nutzen, öffnen Sie die Perforation und setzen Sie in die entstehende Öffnung einen Betonring zwischen der Platte und der angrenzenden Wand ein, siehe Abb. 18 a. Verwenden Sie Acrylkleber, um den Ring mit der Platte zu verbinden.



FR: Si vous utilisez un raccordement de cheminée arrière et un conduit d'air extérieur, effectuer une découpe et placer un anneau en béton entre la plaque et le mur adjacent - voir Fig. 18 a. Utiliser de la colle acrylique pour fixer l'anneau sur la plaque.



CO-MON03-090



FIG 18 a Monaco A Low Base_Q-34 AL + Bench

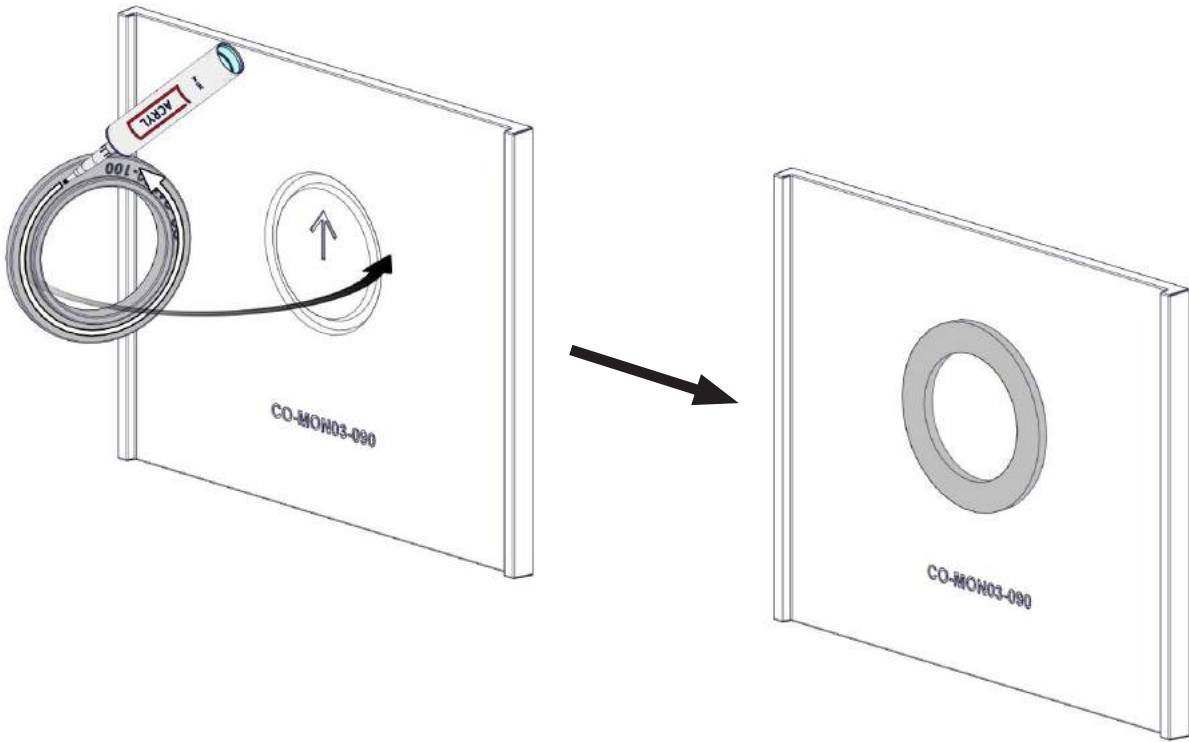

FIG 19 Monaco A Low Base_Q-34 AL + Bench

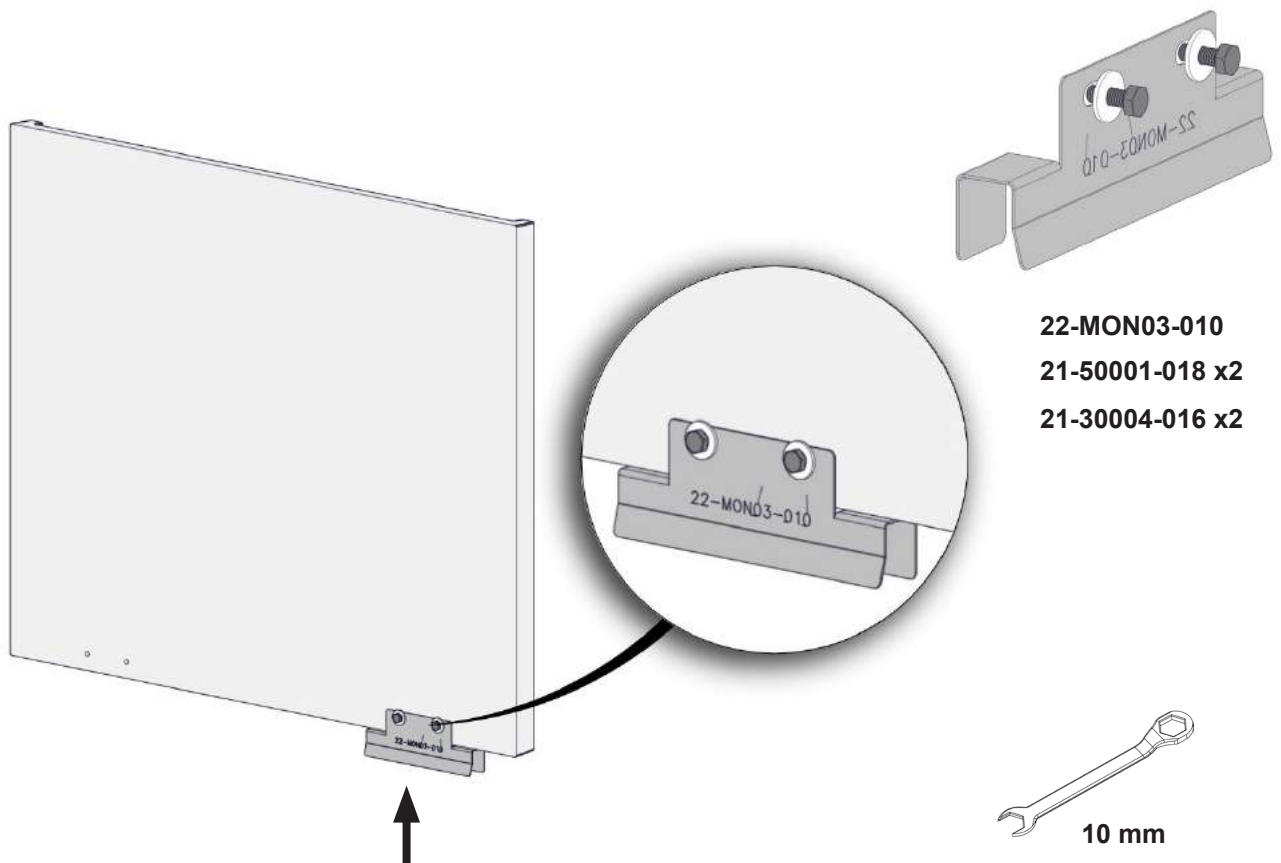

FIG 19 a

Monaco A Low Base_Q-34 AL + Bench

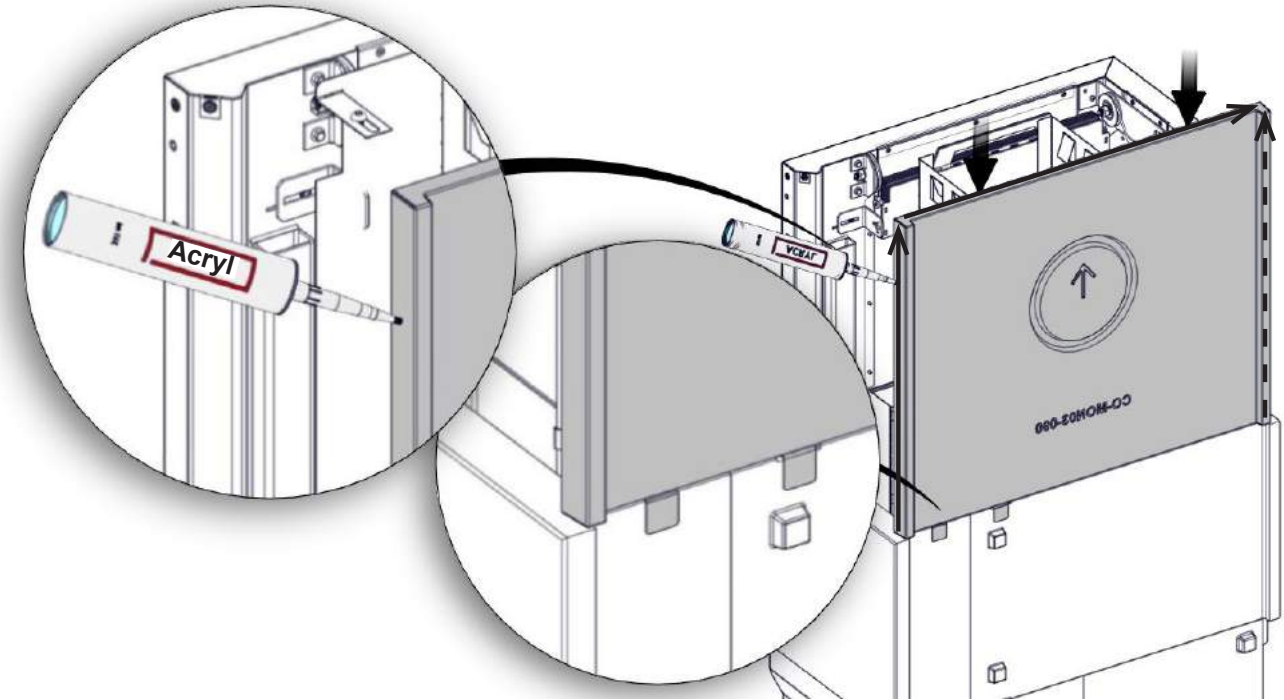
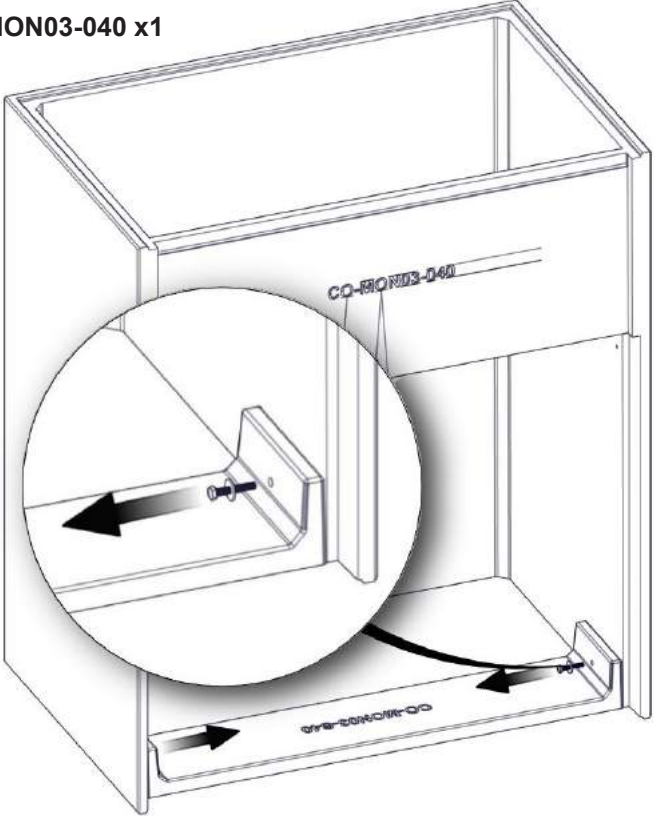

FIG 20

Monaco A Low Base_Q-34 AL + Bench

CO-MON03-040 x1



- CO-MON03-S40 x1
- 21-50001-018 x2
- 21-30004-035 x2

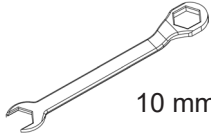

10 mm

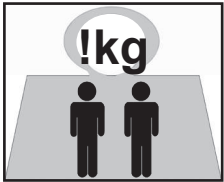

FIG 20 a

Monaco A Low Base_Q-34 AL + Bench

Side tilkobling / Anslutning från sidan / Side connection
Sivuliitäntä / Anschluss seitlich / Raccordement latérale

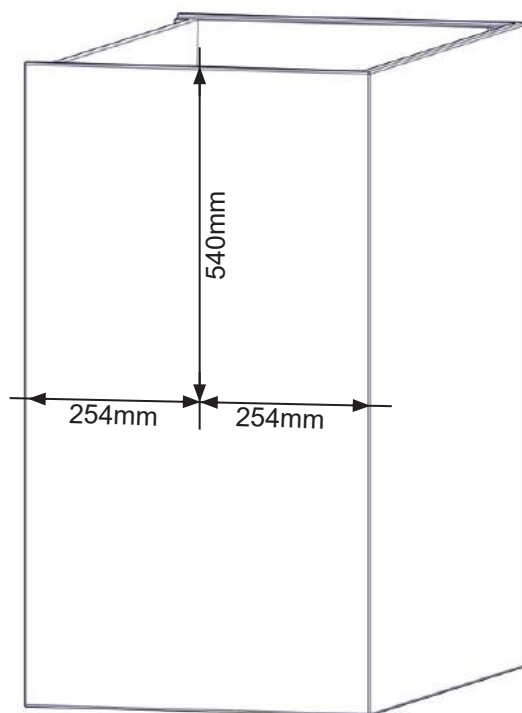

FIG 20 b

Monaco A Low Base_Q-34 AL + Bench

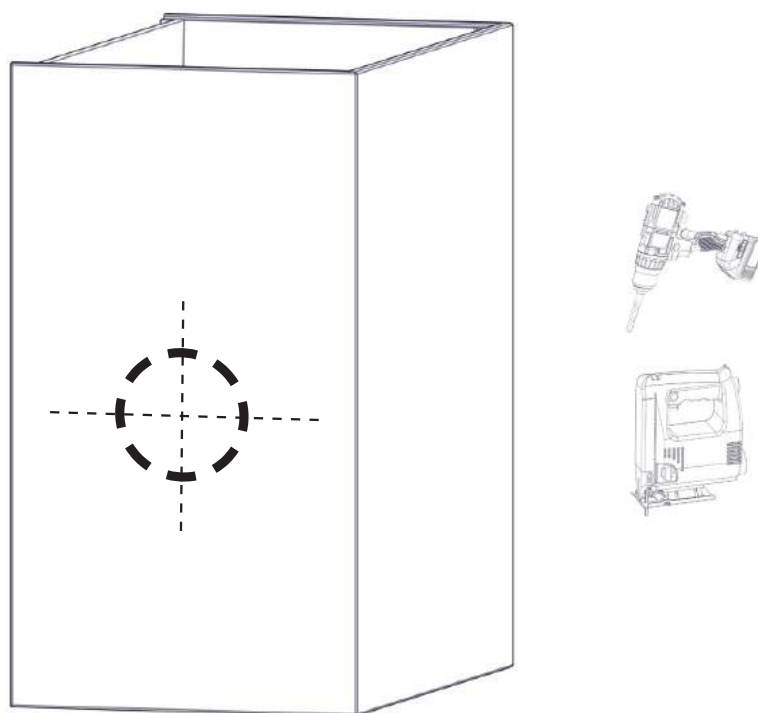

FIG 20 c Monaco A Low Base_Q-34 AL + Bench

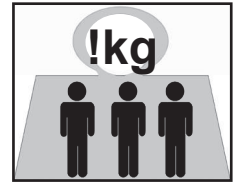
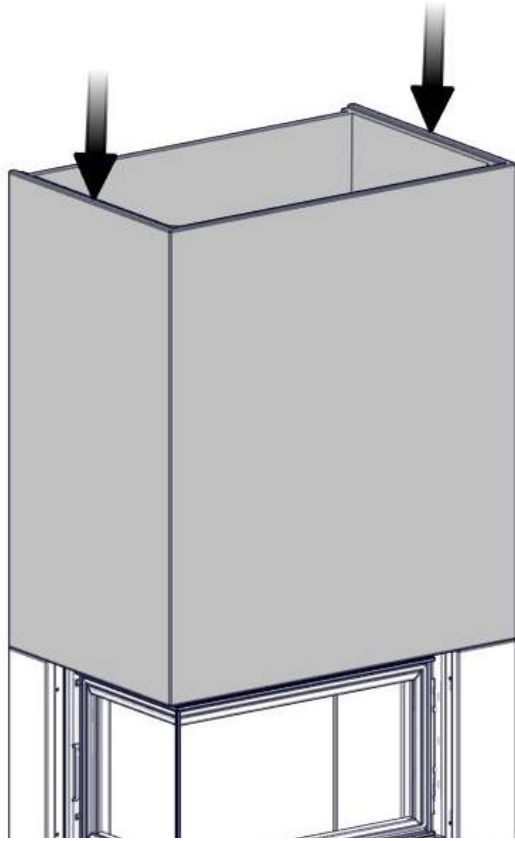
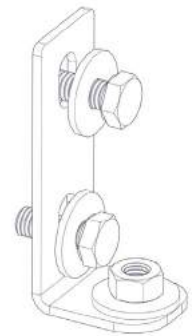
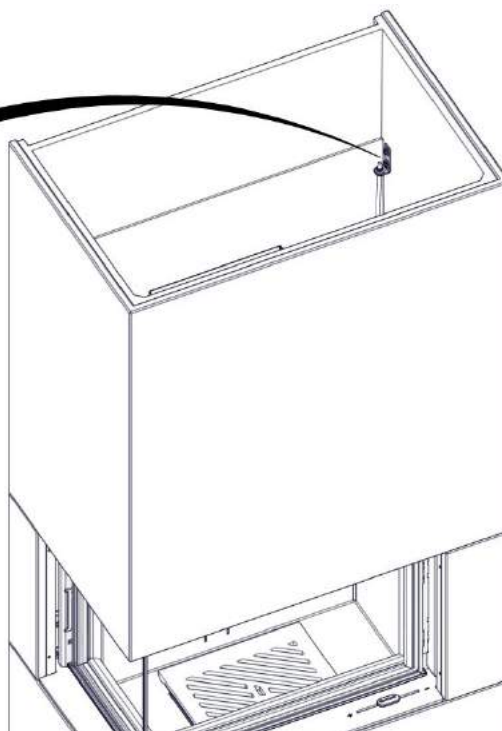
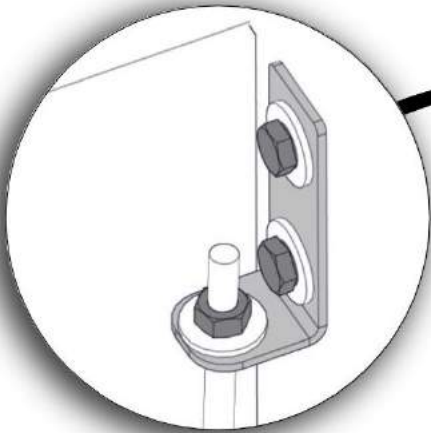
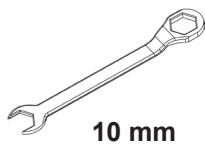

FIG 20 d Monaco A Low Base_Q-34 AL + Bench



- 22-MON03-030
- 21-50001-018 x3
- 21-30004-016 x2
- 21-00000-006 x1



10 mm

FIG 21 Monaco A Low Base_Q-34 AL + Bench

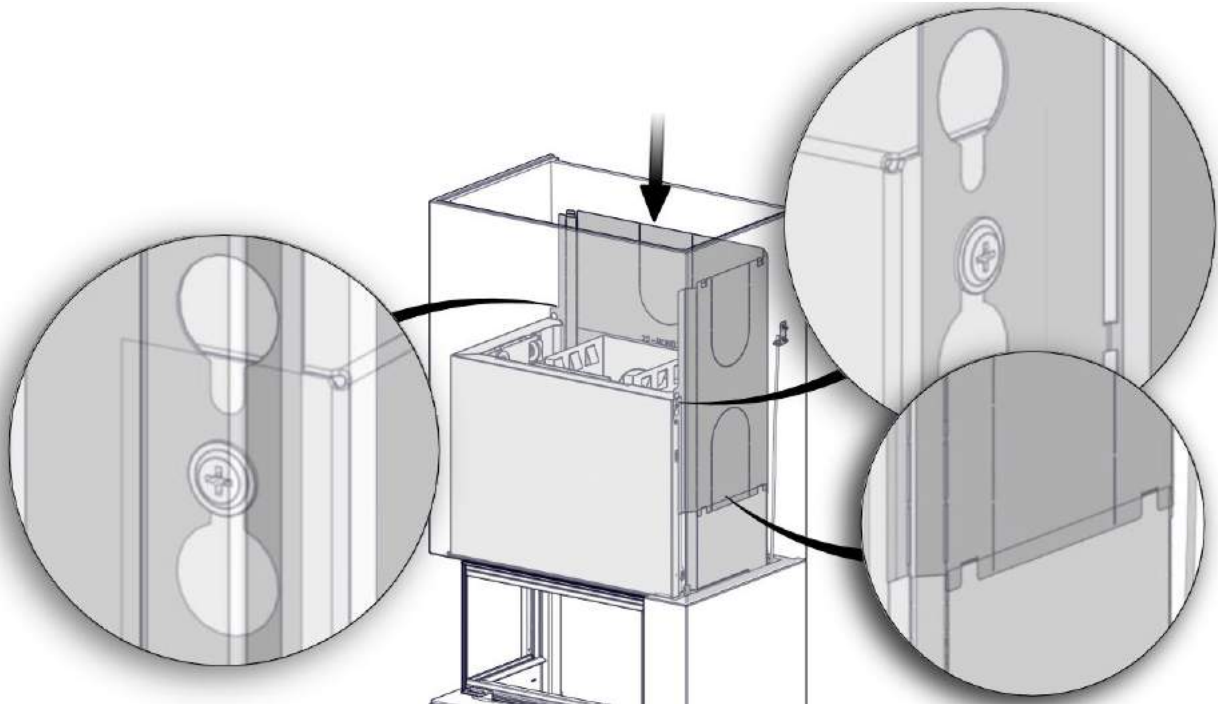

FIG 22 Monaco A Low Base_Q-34 AL + Bench

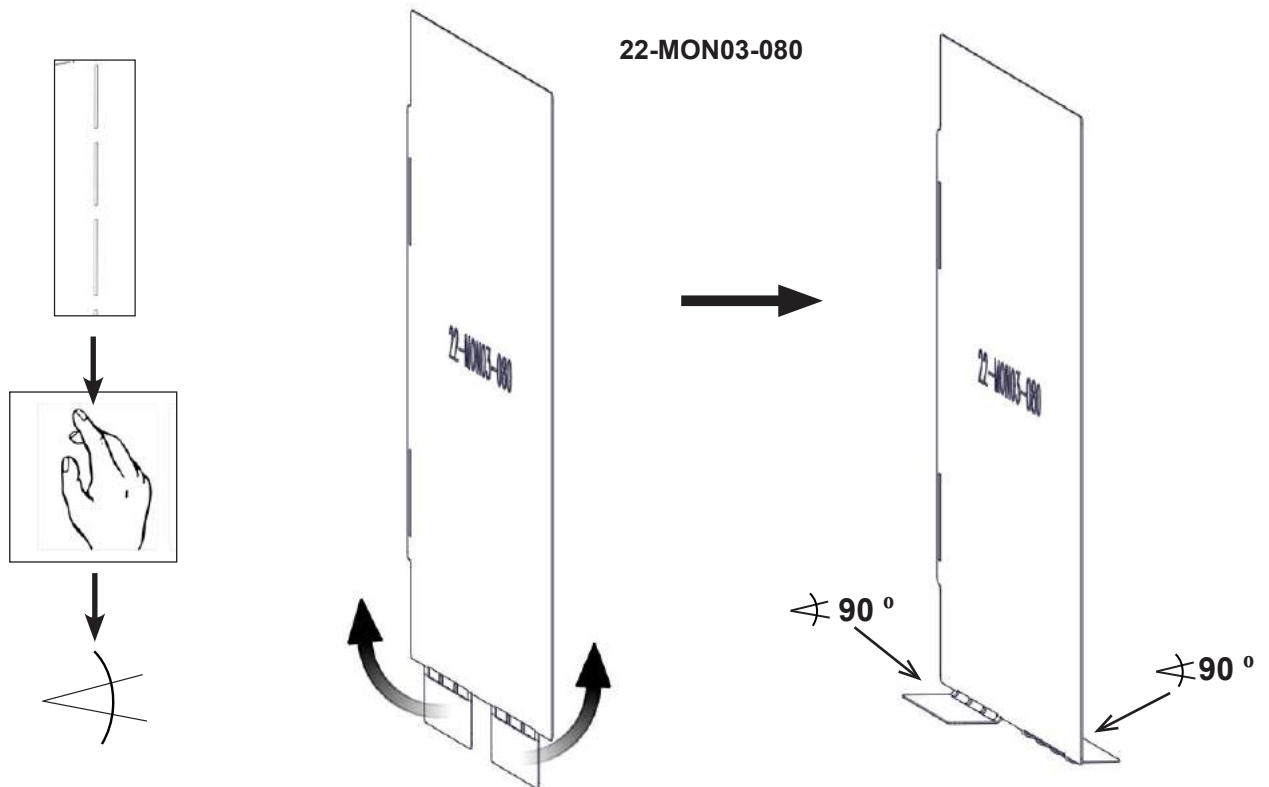

FIG 22 a Monaco A Low Base_Q-34 AL + Bench

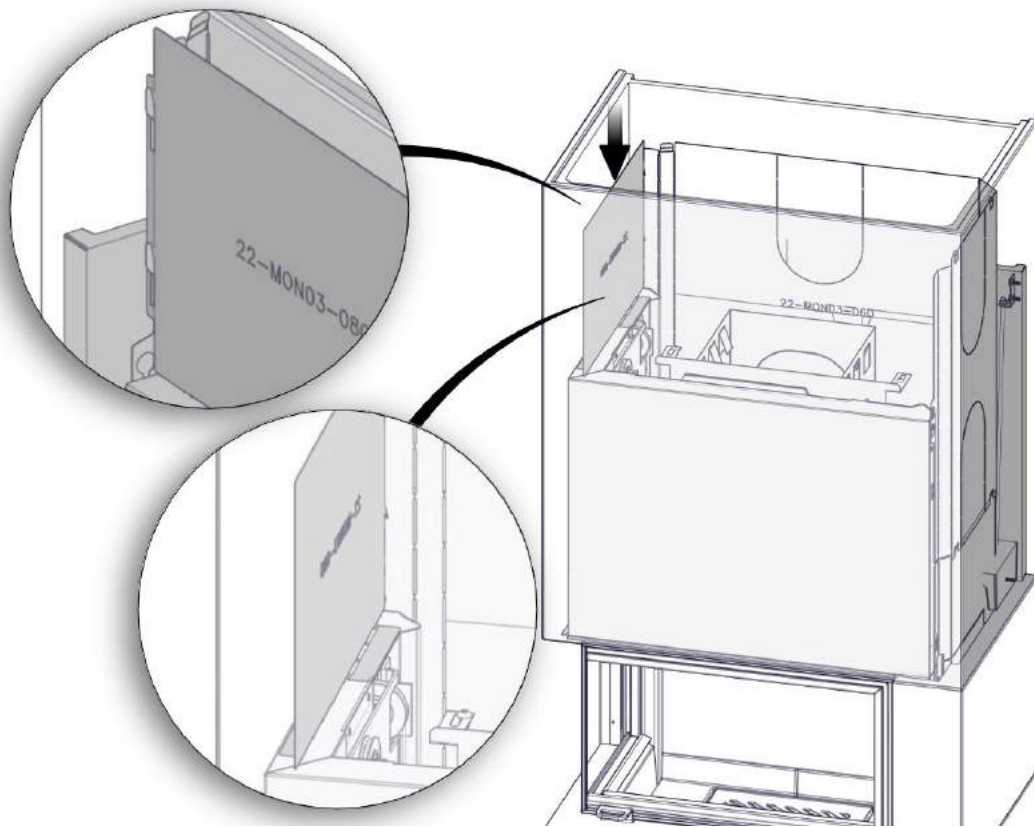

FIG 23 Monaco A Low Base_Q-34 AL + Bench

Top chimney connection

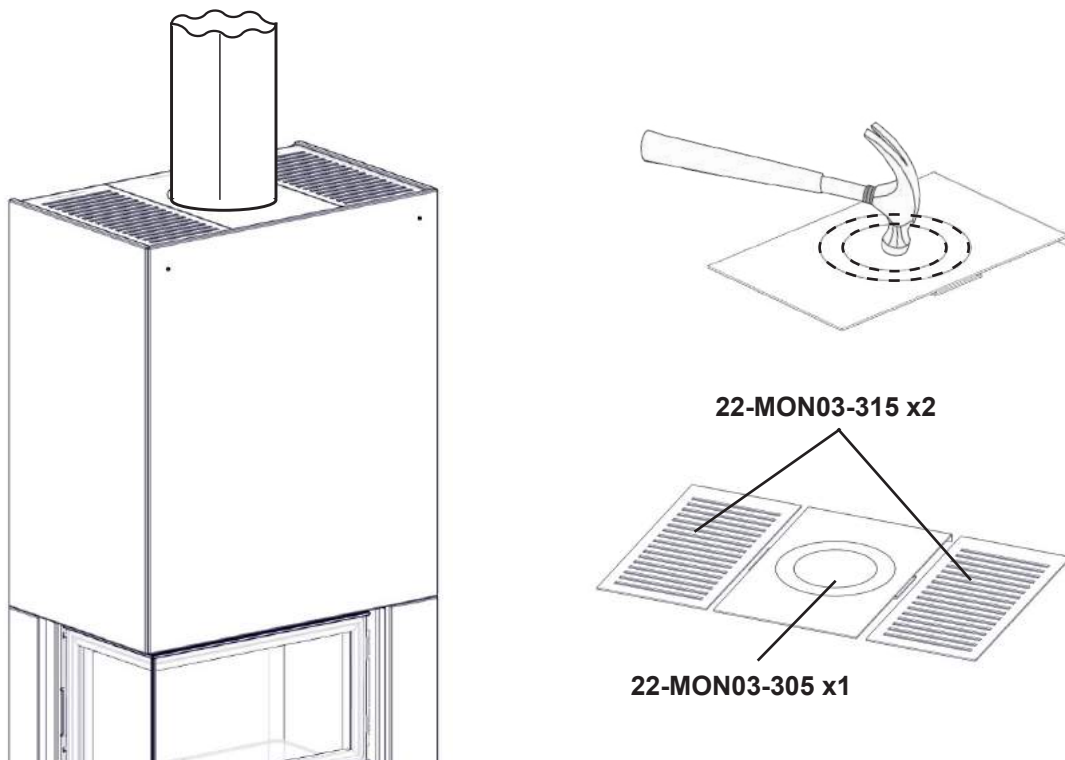

FIG 23 a

Monaco A Low Base_Q-34 AL + Bench

Rear chimney connection

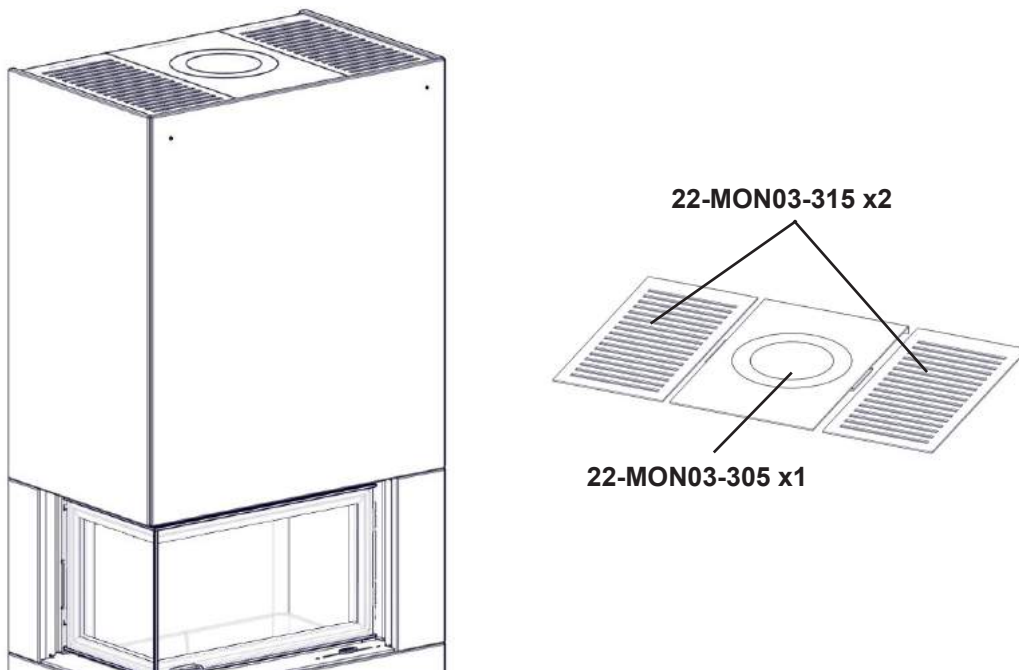

FIG 24

Monaco A Low base_Q-34 AL + Bench

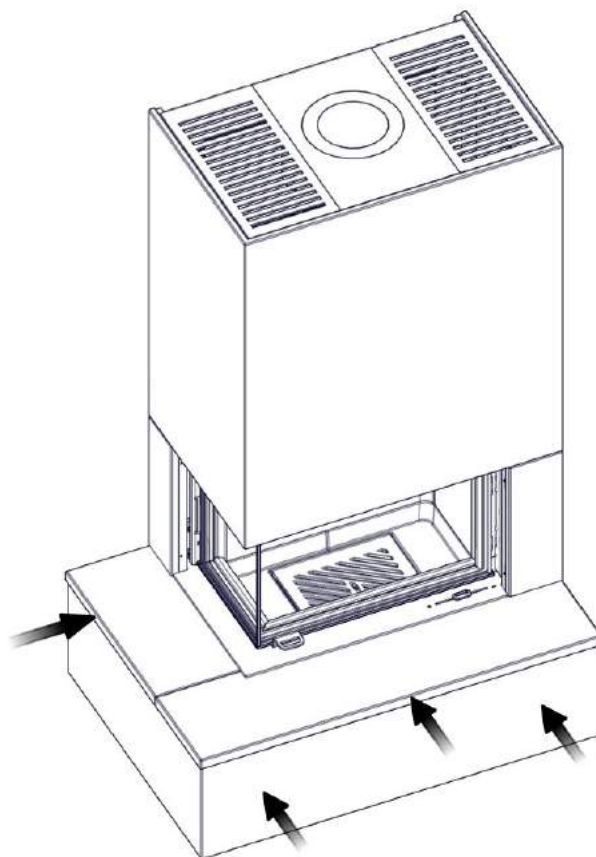
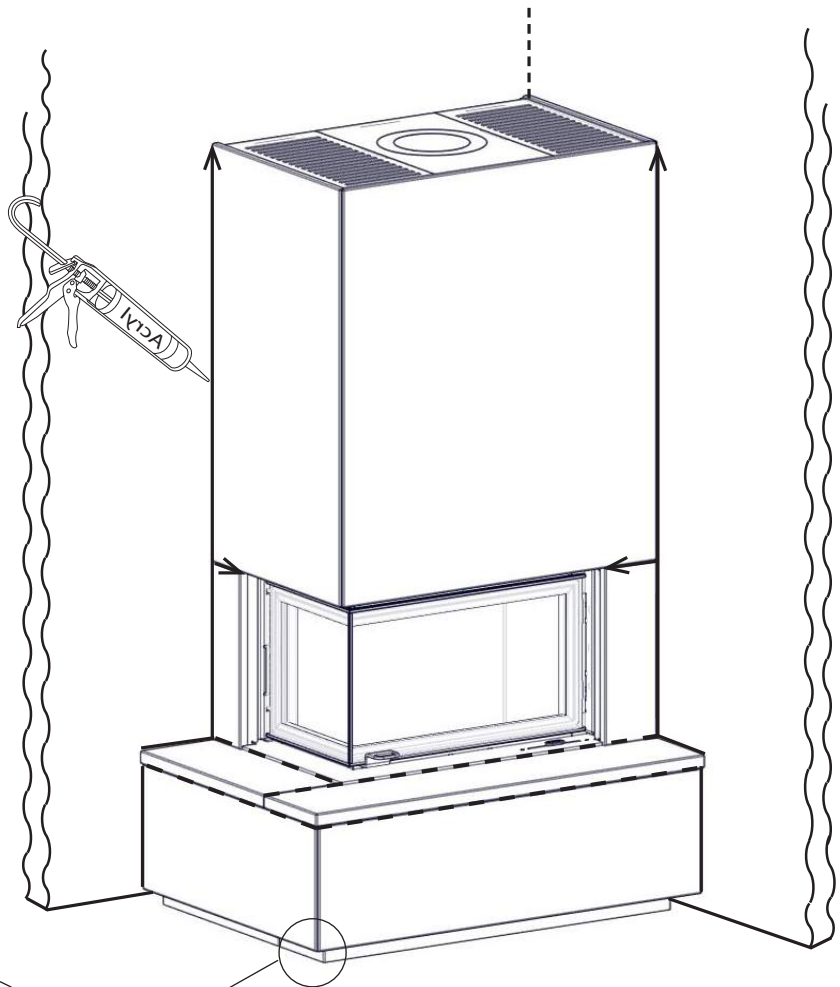
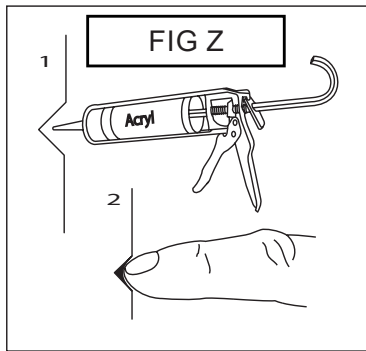

FIG 25

Monaco A Low base_Q-34 AL + Bench



NO: Advarsel! Hold alle luftinntak fri for forbrenningen fri for tildekking.

GB: Warning! Keep the air intakes, supplying combustion air, free from blockage.

SE: Varning! Håll luftintag, som tillför förbränningsluft, fria från blockeringar.

FI: Varoitus! Pidä huoli että kiertoilma-aukot eivät tukkeudu missään tapauksessa.

DE: Warnung! Lufteinlässe, durch die Verbrennungs-luft strömt, dürfen nicht blockiert werden.

FR: Avertissement ! Ne pas obstruer les prises d'air comburant

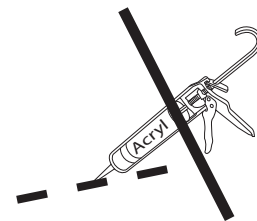
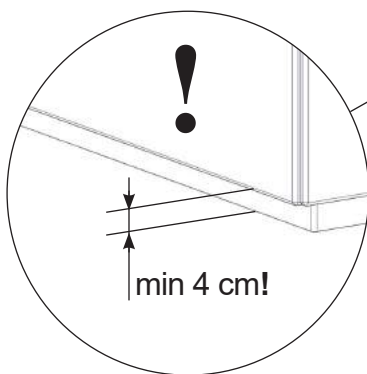

NO: Viktig! For å sikre nødvendig konveksjonsluft, kan kun originale gulv plater fra Nordpeis benyttes.

GB: Attention! In order to secure required convection opening, only original Nordpeis Floor plates should be used.

SE: Obs! För att säkerställa erforderlig konvektionsöppning ska endast Nordpeis originalgolvlattor användas.

FI: Huom! Käytä vain alkuperäisiä Nordpeis-lattialevyjä vaaditun konvektioaukon (ilmankierron) varmistamiseksi.

DE: Achtung! Um die erforderliche Konvektionsöffnung sicherzustellen, dürfen nur Original-Brandschutzplatten von Nordpeis verwendet werden.

FR: Attention! Afin de garantir l'ouverture de convection requise, seules des plaques de sol Nordpeis d'origine doivent être utilisées.

! Service access

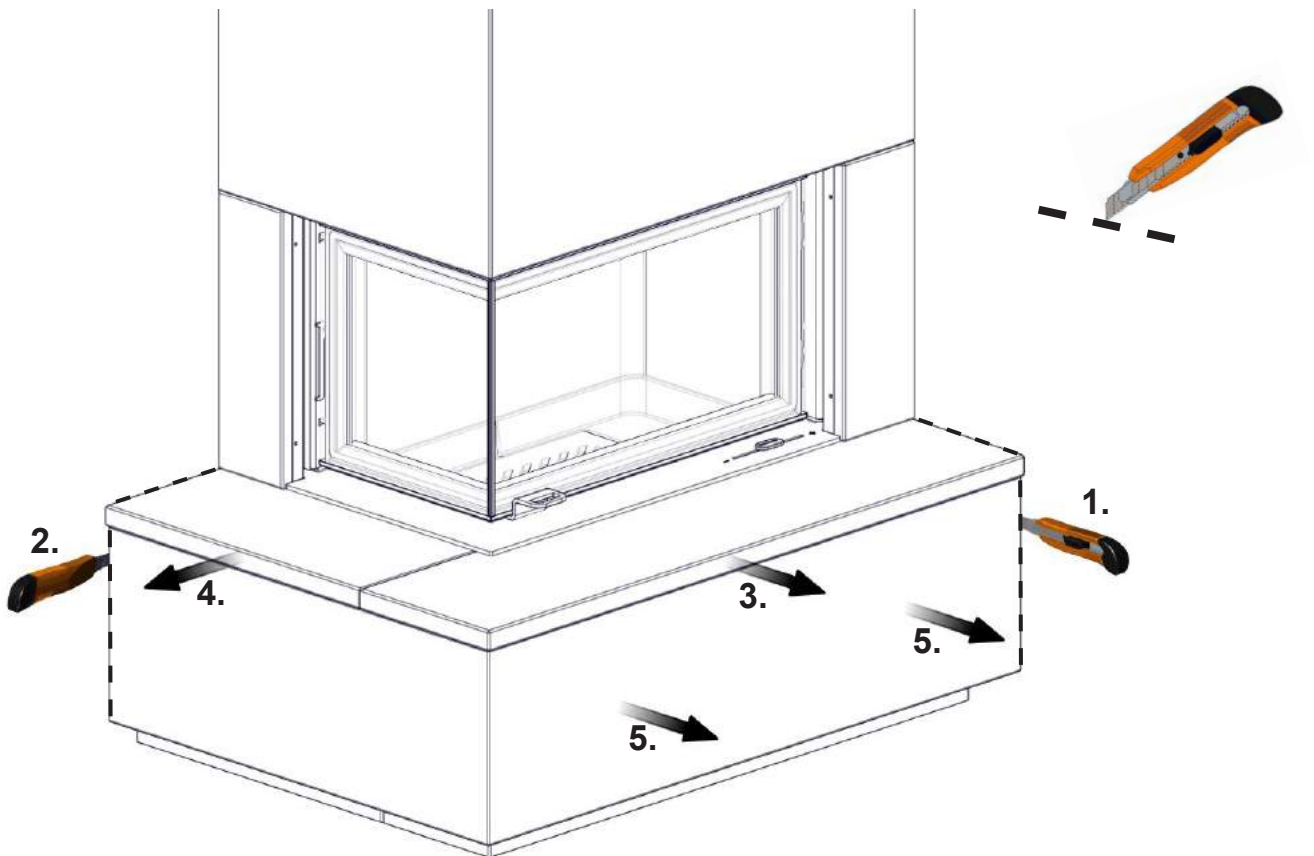

Nordpeis AS
Gjellebekkstubben 11
3420 Lierskogen, Norway
MonacoA-CPR-2019/10/16



EN 13240:2001 / A2:2004 / AC:2007

Monaco A Low / High

Year of Approval / Zulassungsjahr 2017

Heating of living accomodation / Kamin zum Heizen mit festen Brennstoffen

Fire safety:	Feuersicherheit :	
Reaction to fire:	Brandverhalten:	A1 WT
Distance to combustible:	Abstand zu brennbaren Materialien:	
Behind:	Hinten:	0 mm
Beside:	Seitlich:	200/0 mm(*)
Emission of combustion	Emissionwerte:	CO: 0,07% vol
		NOx: 91 mg/m ³
		OGC: 59 mg/m ³
		PM: 17 mg/m ³
Surface temperature:	Oberflächentemperatur:	Pass / Bestanden
Machanical resistance:	Mechanischer Widerstand:	Pass / Bestanden
Cleanability:	Reinigungsfähigkeit:	Pass / Bestanden
Thermal Output	Nennwärmeleistung - NWL	7,0kW
Energy efficiency:	Wirkungsgrad:	81 %
Flue gas temperature:	Abgastemperatur:	273 °C
Fuel types:	Brennstoff:	Wood logs / Scheitholz

Intermittent burning / Zeitbrandfeuerstätte

(*) Read and follow the manual / Lesen und befolgen Sie die Bedienungsanleitung
Double allocation is acceptable / Mehrfachbelegung des Schornsteins ist zulässig

Complies with / Entspricht folgenden Standards:	Test report / Prüfbericht Nr :
Art 15a B-VG; LRV of Switzerland BlmSchV 1, 2; NS 3058/59 Flamme Verte 7*****	RRF - 40 17 4637
	SN:

Nordpeis

Nordpeis AS, Gjellebekkstubben 11, N-3420 LIERSKOGEN, Norway
www.nordpeis.no