

2021+ Ford F-150
Side Exit



IMPORTANT! WARRANTY AND INSTALLATION INSTRUCTIONS

Please Forward All Information to End Consumer

Be sure to review the enclosed instructions prior to beginning the installation process. If you have any questions about the enclosed parts or instructions, or if you encounter a problem during installation:

CALL TECHNICAL SUPPORT: 440.891.0999 or 800.486.0999

TO ACTIVATE YOUR WARRANTY, GO TO:
corsaperformance.com/warranty

COLOR INSTRUCTIONS ARE AVAILABLE BY PART NUMBER ON:
corsaperformance.com



NEVER work on a hot exhaust system.
Allow time for the vehicle to cool.

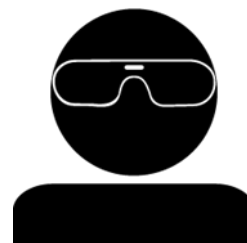

**Always wear eye protection
when working under a vehicle.**

INSTALL DIFFICULTY



Recommended Tools & Supplies

- 10mm Socket & Ratchet or Wrench
- 13mm Socket & Ratchet or Wrench
- 15mm Socket & Ratchet or Wrench
- Grommet Pulling Pliers or Similar
- Torque Wrench
- Extension for Socket & Ratchet
- Soap and Water Solution (for removing and installing Factory Grommets)

Please take time to read and understand these installation instructions.

CORSA recommends that the installation of this system be performed by a qualified service center or professional installer who has the necessary equipment, tools, and experienced personnel. However, if you decide to perform this installation yourself, the use of an additional person may be required.

WARNING: Never work on a hot exhaust system. Allow time for the vehicle to cool.
Always wear eye protection when working under a vehicle.

This warranty does not extend to damaged or defect in the finish of a product or to any product, that in the opinion of CORSA Performance, has been misused, damaged by accident or negligence, altered, or modified in any way, faulty installation or installed contrary to CORSA installation instructions, or repaired by an unauthorized service facility. Full warranty available on www.corsaperformance.com

Please confirm that all parts are present according to the bill of materials before beginning the installation.

If something is missing, call CORSA Tech Support at 440.891.0999 or Toll Free: 1.800.486.0999

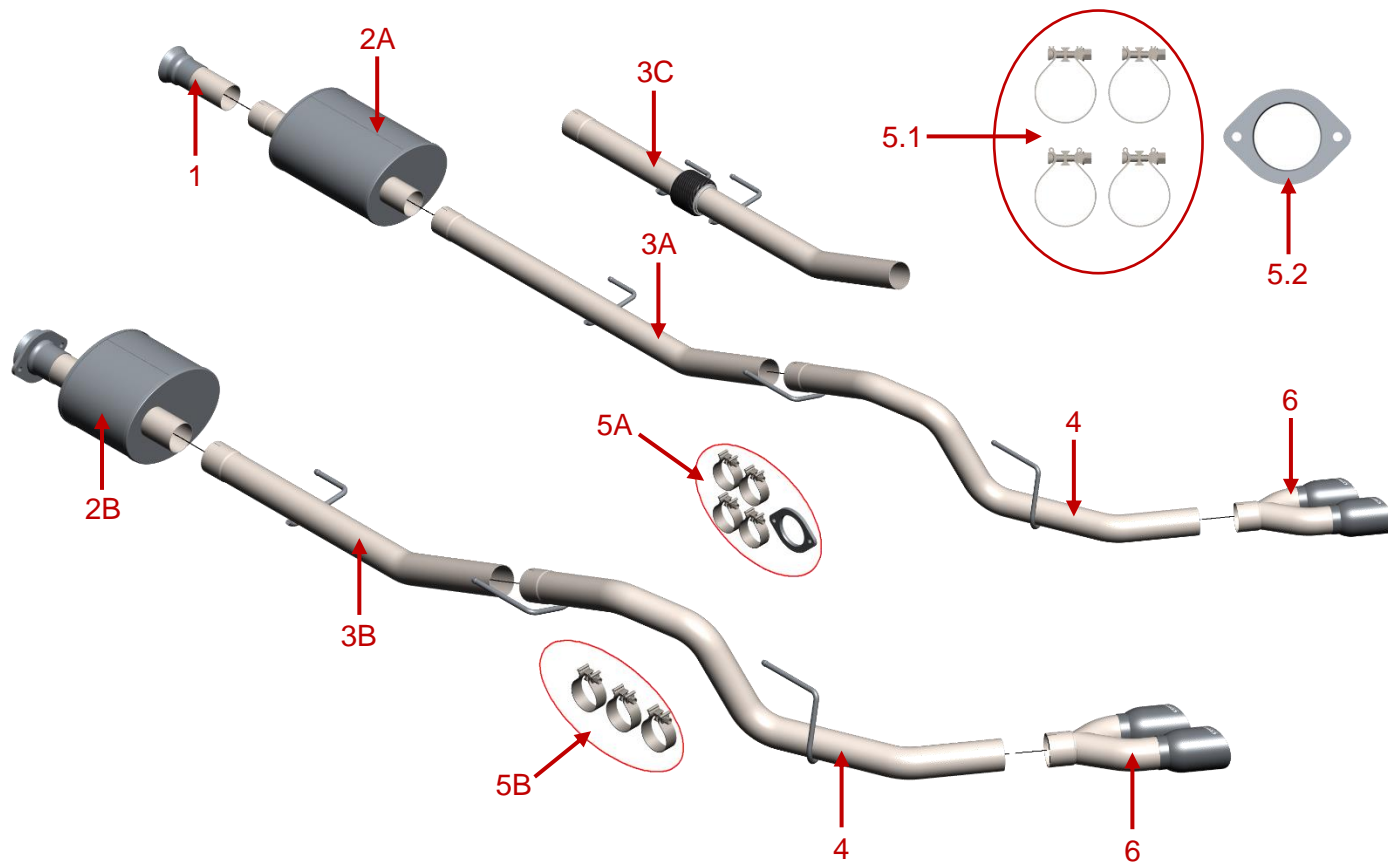

Bill of Materials

1. Head Pipe**	SPORT - 20FF4214 - 145in, 20FF4215 - 157in XTREME - 20FF4211 - 141in, 20FF4212 - 145in, 20FF4213 - 157in	
2. Muffler	(A) 20FF2038 - SPORT 3.5L 145in+ WB, 20FF2039 - XTREME 5.0L 141in+ WB 20FF2044 - SPORT 5.0L 145in+ WB (B) 20FF2037 - SPORT 3.5L 141in WB, 20FF2040 - XTREME 5.0L 122in WB 20FF2043 - SPORT 5.0L 141in WB	
3. Mid Pipe	(A) 20FF4193 – 5.0L141in+ WB, (B) 20FF4189 – 5.0L 122in WB (C) 20FF4232 – 3.5L 141in+ WB	
4. Tail Pipe	20FF4199	
5. Hardware Kit	Contents: 5.1 16CF7001 - 3in Clamp (QTY 4) 5.2 20FF5008 - Head Pipe Flange	Contents: 5.1 16CF7001 - 3in Clamp (QTY 3)
6. Tip Assembly	16TA3000 or 16TA3000BLK	
7. Instructions	INS5427 (This Document)	

** A Head Pipe is not required and the Head Pipe Flange is preassembled on the Muffler inlet in Kits:
21142, 21142BLK, 21154, 21154BLK 21163, 21163BLK

If something is missing, call CORSA Tech Support at 440.891.099 or Toll Free: 1.800.486.0999

Removal Instructions

Factory Exhaust

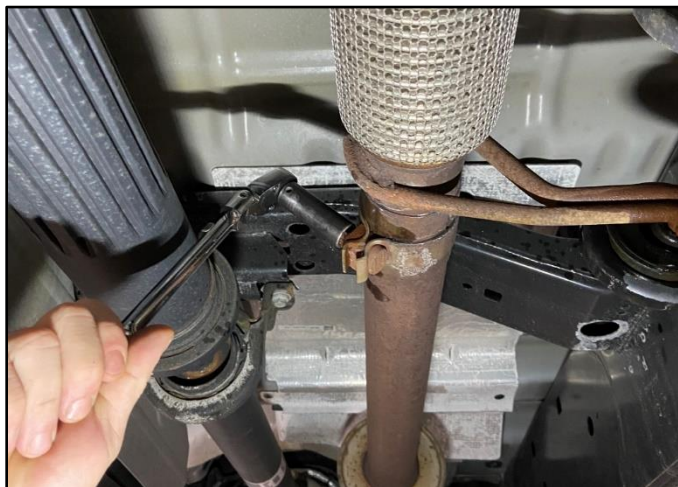

1. Use a 15mm Socket & Ratchet or Wrench to loosen the Stock Clamp, connecting the Front Section and Rear Section of the Stock exhaust.

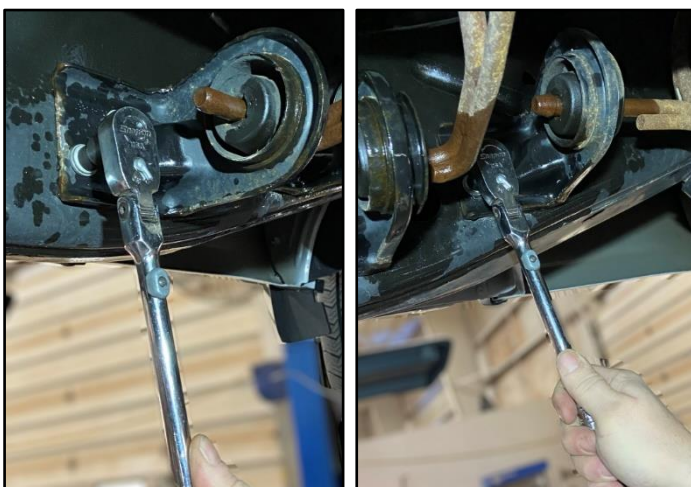

2. Use a 10mm Socket & Ratchet or Wrench to remove the 2 Bolts on each of the Factory Grommets. If the Factory Exhaust has a Flex Section, there are two Grommets. If the Factory Exhaust does not have a Flex Section, there is one Grommet and may look different than shown.

Keep the Bolts in a safe place. They will be reinstalled on Installation Step 10.

Keep the Factory Grommet(s) on the Stock Exhaust. They will be installed on the CORSA Exhaust in Installation Step 1.

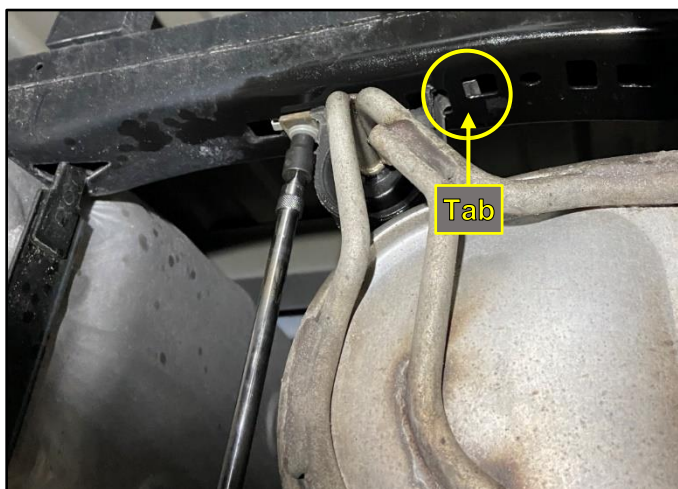

3. Locate the Middle Factory Grommets and use a 10mm Socket & Ratchet with an Extension or Wrench to remove the Bolt that attaches it to the Frame. Pull the Factory Grommet toward where the Bolt was attached. This releases a tab from a hole in the Frame.

Continued on Next Page...

Removal Instructions

Factory Exhaust



4. Above the Rear Axle, locate the Rear Factory Grommet and use a 10mm Socket & Ratchet with an Extension or Wrench to remove 1 the of bolts that attaches it to the Frame. One Bolt is vertical, on the bottom of the Frame. The other is on the inside of the Frame and is horizontal.
5. Once the first bolt is removed, support the Rear Section of the Factory Exhaust. A second person may be needed to assist with this step. Remove the second Bolt using a 10mm Socket & Ratchet with an Extension or Wrench and gently lower the Rear Section of the Factory Exhaust until it rests on the Rear axle.

6. To begin removing the Rear Section of the Factory Exhaust, rotate the entire Rear Section so the Stock Tip moves up toward the cavity behind the rear tire. This unlocks the key in the joint where the two Factory Exhaust sections connect. The key is on top of the Factory Exhaust (see image below for location). Once the key is unlocked, the Rear Section can be pulled toward the rear of the vehicle to disconnect from the Front Section. Once disconnected, the Rear Section is removed by moving it forward, over the Rear Axle, and then out from under the vehicle. A second person may be needed to assist with this step.



Continued on Next Page...

Removal Instructions

Factory Exhaust

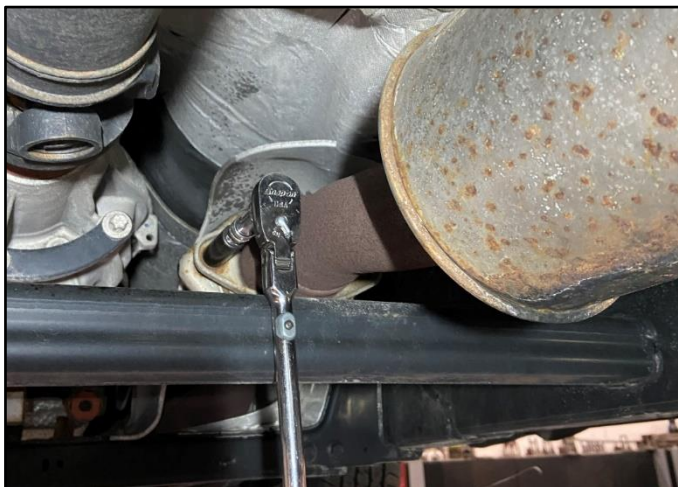

- Use a 13mm Socket & Ratchet or Wrench to loosen the bolts from Stock Flange connection on the Front Section of the Stock exhaust. A second person may be needed to support the Front Section of the Stock exhaust.

After removing the bolts, the Front Section of the Stock exhaust can be removed from under the vehicle.

Keep the Bolts in a safe place. They will be reinstalled on Installation Step 6 or 8.

This concludes the removal of the factory exhaust.

WARNING!!

DO NOT SKIP THIS STEP

WARNING!!

Apply the supplied Anti-Seize Lubricant to **ONLY** the threads of the clamps and flange bolts. Failure to follow this procedure can cause nuts to seize on clamps and potentially destroy the threads.

After applying anti-seize lubricant, be sure to thoroughly clean your hands. The Anti-Seize lubricant will tarnish stainless steel.

All clamps should be tightened using a properly calibrated Torque Wrench. Using an impact gun will damage the clamp and reduce its ability to effectively seal the joint. It may also cause the joint to separate, thereby causing damage to your exhaust system and to your vehicle.

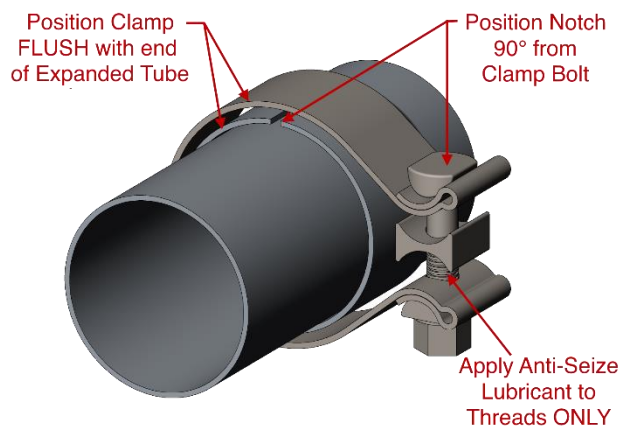

PRO TIP

Before installing, make a line from the end of non-expanded side of the pipes and muffler that is $1\frac{5}{8}$ in on $2\frac{3}{4}$ in tubing and $1\frac{3}{4}$ in on 3in tubing. These are CORSA's nominal joint overlaps. This will help during final adjustment. Do not be alarmed if the overlap varies slightly when the installation is complete. Any differences are caused by manufacturing variances from vehicle to vehicle and exhaust to exhaust.

Install Instruction

CORSA Exhaust



1. Remove the Factory Grommet(s) using Grommet Pulling Pliers or similar from the Factory Muffler and Head Pipe (if equipped with Flex).

Note the orientation of the grommet(s) for the next step.

The use of a soap and water solution will aid in the removal of the hangers from the Factory Grommets.



2. Locate the CORSA Mid Pipe. Install the Factory Grommet(s) from Step 1 on to the Mid Pipe.

Make sure to orient the Factory Grommet(s) as indicated on the Factory exhaust.



3. Remove the Factory Grommet(s) using Grommet Pulling Pliers or similar from the rear of the Factory Muffler and Tail Pipe.

Note the orientation of the grommet(s) for the next step.



4. Locate the CORSA Side Exit Tail Pipe. Install the Factory Grommets from Step 3 on to the Tail Pipe.

Make sure to orient the Factory Grommets as indicated on the Factory exhaust.

Continued on Next Page...

Install Instruction

CORSA Exhaust



- 5.** If installing a CORSA exhaust with a preassembled Head Pipe Flange on the muffler, skip to Step 8.

If installing a CORSA exhaust with a Head Pipe Flange in the Hardware Kit, locate the Head Pipe. Assemble the Head Pipe Flange onto the Head Pipe, with the chamfer side toward the Flare.

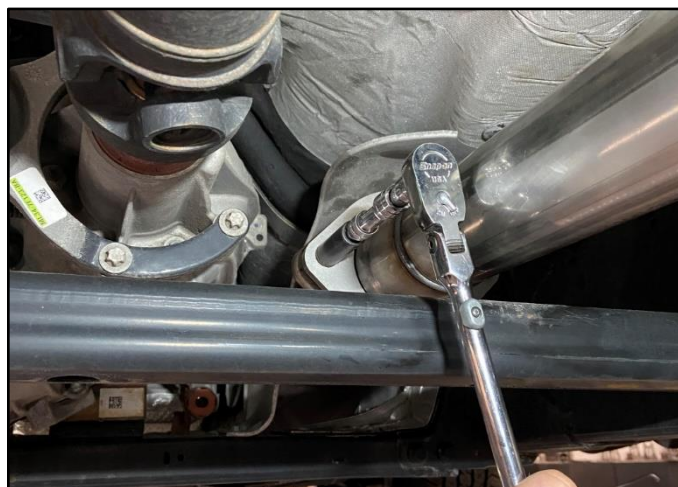

- 6.** Locate the Head Flange Bolts from Removal Step 7. A second person may be needed to assist with this step.

Lift the CORSA Head Pipe with assembled Flange into position. Then, carefully start threading the Head Flange Bolts into the Factory Connection.

Then lightly **SNUG** the Bolts with a 13mm Socket & Ratchet with Extension or Wrench. This joint needs to be loose enough for alignment later but snug enough to support the CORSA Head Pipe and Muffler.

DO NOT FULLY TIGHTEN at this time!



- 7.** Locate 1 – 3in Clamp from the Hardware Kit and slide it over the Head Pipe. A second person may be needed to assist with this step.

Lift the CORSA Muffler into position and slide the expanded inlet over the Head Pipe outlet. While supporting the CORSA Muffler, confirm the joint overlap and clearances to the vehicle, then **SNUG** the Clamp with a 15mm Socket & Ratchet or Wrench.

DO NOT FULLY TIGHTEN at this time!

Skip to Step 9.

Continued on Next Page...

Install Instruction

CORSA Exhaust



- 8.** Locate the Head Flange Bolts from Removal Step 7. A second person may be needed to assist with this step.

Lift the CORSA Muffler with preassembled Flange into position. While supporting the CORSA Muffler, carefully start threading the Head Flange Bolts into the Factory Connection.

Then lightly **SNUG** the Bolts with a 13mm Socket & Ratchet with Extension or Wrench. This joint needs to be loose enough for alignment later but snug enough to support the CORSA Muffler.

DO NOT FULLY TIGHTEN at this time!

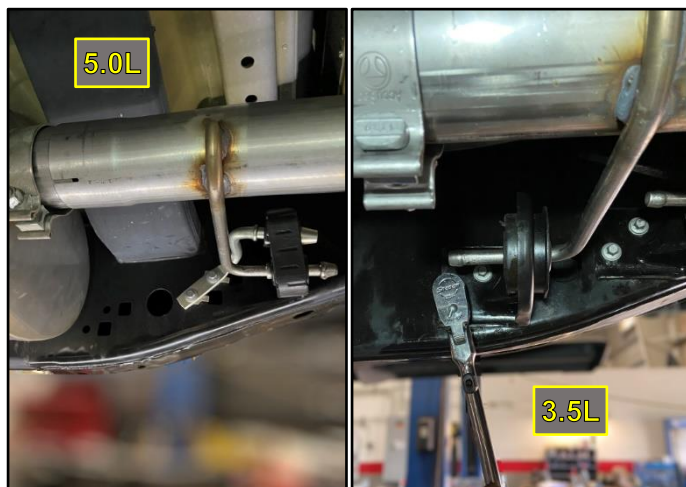

- 9.** Locate 1 – 3in Clamp from the Hardware Kit and slide onto the CORSA Muffler Outlet.
- 10.** Locate the Bolts from the Factory Grommet(s) from Removal Step 2. A second person may be needed to assist with this step.

Lift the CORSA Mid Pipe into position and slide the expanded inlet over the Muffler outlet. While supporting the Mid Pipe, carefully thread the Bolts thru the Factory Grommet(s) and into the Factory Clip Nuts in the Frame. Use a 10mm Socket & Ratchet or Wrench to **SNUG** the Bolts.

DO NOT FULLY TIGHTEN at this time!

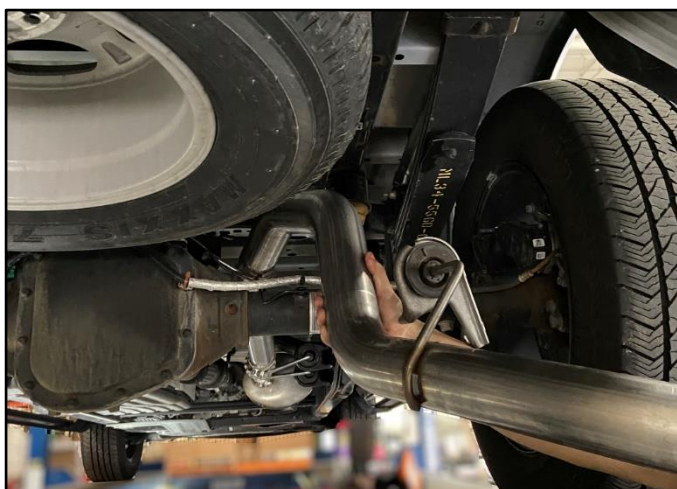

- 11.** Locate 1 – 3in Clamp from the Hardware Kit and slide onto the CORSA Mid Pipe Outlet.
- 12.** Locate the CORSA Side Exit Tail Pipe with the Factory Grommets installed. A second person may be needed to assist with this step.

Lift the Tail Pipe over the Rear Axle from the back of the vehicle and slide the expanded inlet over the Mid Pipe outlet.

Continued on Next Page...

Install Instruction

CORSA Exhaust

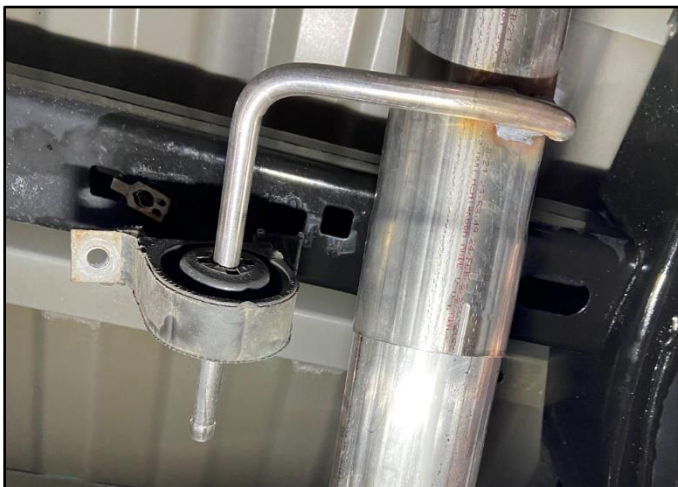

- 13.** Locate the bolt for the Middle Factory Grommet from Removal Step 3. A second person may be needed to assist with this step.

While supporting the Mid Pipe and Tail Pipe, insert the tab on the Grommet into the hole in the vehicle frame and carefully thread the Bolt thru the Factory Grommet and into the Factory Clip Nut in the frame. Use a 10mm Socket & Ratchet or Wrench to **SNUG** the bolt.

DO NOT FULLY TIGHTEN at this time!



- 14.** Locate the bolts for the Rear Factory Grommet from Removal Step 4 and 5. A second person may be needed to assist with this step.

While supporting the Tail Pipe, carefully thread the top Bolt thru the Factory Grommet and into the Factory Clip Nut in the frame and repeat for the bottom Bolt. Use a 10mm Socket & Ratchet or Wrench to **SNUG** the bolts.

DO NOT FULLY TIGHTEN at this time!



- 15.** Use a 15mm Socket & Ratchet or Wrench to **SNUG** the Clamps connecting the CORSA Muffler to the Mid Pipe and the Mid Pipe to the Tail Pipe.

DO NOT FULLY TIGHTEN at this time!

Continued on Next Page...

Install Instruction

CORSA Exhaust



- 16.** Locate 1 – 3in Clamp from the Hardware Kit and slide it over the outlet of the Tail Pipe

Lift the CORSA Tip Assembly into position and slide the expanded inlet over the Tail Pipe outlet, while supporting the Tail Pipe. Align the CORSA Tip Assembly with the vehicle body line, leaving an even clearance between the tips and vehicle body.

- 17.** Use a 15mm Socket & Ratchet or Wrench to **SNUG** the Clamp connecting the CORSA Tip Assembly and Tail Pipe.

DO NOT FULLY TIGHTEN at this time!

- 18.** Starting at the Flare Connection, verify the Hangers are properly in the Grommets, the Muffler is close to level, all connections are straight and there is proper clearance around the entire CORSA Exhaust and the Vehicle. Then starting at the Flange Connection, use a Torque Wrench to tighten the clamps to 45ft-lbs and the Factory Hanger Bolts and Flare Connection to Factory specifications.

A second person may be needed to hold the components in the correct position while the clamps are being torqued.

This concludes the installation of the CORSA Exhaust.

Before Road Testing

- 1.** Start engine, leaving the transmission in park and/or securing the parking brake.
- 2.** Make sure to look and listen for any unusual noises. Repair problems if needed.
- 3.** Immediately following the installation of your exhaust system, you may experience a trace of smoke after initial start-up. Do not be alarmed. The smoke is caused by the burning of a small amount of forming oil residue used in the manufacturing process.
- 4.** It is strongly suggested that the alignment of the components be checked and all clamps re-torqued after road testing the vehicle and allowing the system has fully cooled.
- 5.** During cold weather start-ups, you may experience an exhaust sound that is deeper and louder in tone than usual. This is temporary and will diminish to normal levels once your engine has reached its normal operating temperature.