

2019+
Chevrolet Silverado/GMC Sierra



IMPORTANT! WARRANTY AND INSTALLATION INSTRUCTIONS

Please Forward All Information to End Consumer

Be sure to review the enclosed instructions prior to beginning the installation process. If you have any questions about the enclosed parts or instructions, or if you encounter a problem during installation:

CALL TECHNICAL SUPPORT: 440.891.0999 or 800.486.0999

TO ACTIVATE YOUR WARRANTY, GO TO:
corsaperformance.com/warranty

COLOR INSTRUCTIONS ARE AVAILABLE BY PART NUMBER ON:
corsaperformance.com



NEVER work on a hot exhaust system.
Allow time for the vehicle to cool.

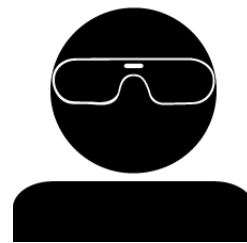

Always wear eye protection
when working under a vehicle.

INSTALL DIFFICULTY 

Recommended Tools & Supplies

- 13mm Socket & Ratchet or Wrench
- 15mm Socket & Ratchet or Wrench
- Torque Wrench
- Marking Pen or Marker
- Grommet Pulling Pliers or Similar
- Soap and Water Solution
- Chain Style Pipe Cutter or Similar
- Tape measure

Please take time to read and understand these installation instructions.

CORSA recommends that the installation of this system be performed by a qualified service center or professional installer who has the necessary equipment, tools, and experienced personnel. However, if you decide to perform this installation yourself, the use of an additional person may be required.

WARNING: Never work on a hot exhaust system. Allow time for the vehicle to cool.
Always wear eye protection when working under a vehicle.

This warranty does not extend to damaged or defect in the finish of a product or to any product, that in the opinion of CORSA Performance, has been misused, damaged by accident or negligence, altered, or modified in any way, faulty installation or installed contrary to CORSA installation instructions, or repaired by an unauthorized service facility. Full warranty available on www.corsaperformance.com

Please confirm that all parts are present according to the bill of materials before beginning the installation.

2019+ Chevrolet Silverado/GMC Sierra

Cat-Back Exhaust Dual Rear Exit

Kits: 21028, 21033, 21034, 21043,
21199, 21200, 21201, 21202, 21211,
21238, 21239

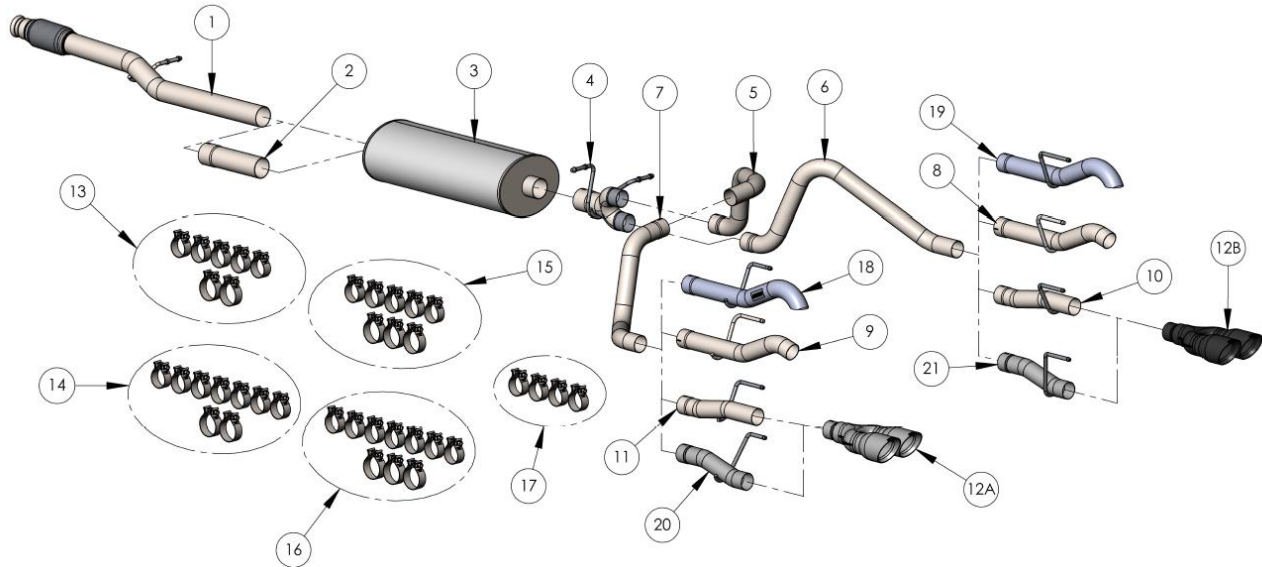

Bill of Materials

1.	Head Pipe (5.3L - 16SE4542 or 6.2L - 16SE4562)	2.	157in WB Extension (Used on 21034, 21043, 21201 and 21202)
3.	Muffler (16TA2019)	4.	Wye Assembly (16SE4551)
5.	Driver Front Axle Pipe (16SE4582)	6.	Passenger Axle Pipe (16SE4557)
7.	Driver Rear Axle Pipe (16SE4583)	8.	Passenger Tail Pipe for Bezels (16SE4553)
9.	Driver Tail Pipe for Bezels (16SE4554)	10.	Passenger Tail Pipe for Tips (16SE4585)
11.	Driver Tail Pipe for Tips (16SE4584)	12.	Tip Assembly (A – 16SE3042 / B – 16SE3042BPC)
13.	Hardware Kit (16SE7118 for 21028 and 21033)	14.	Hardware Kit (16SE7118 for 21028 and 21033)
15.	Hardware Kit (16SE7122 for 21199 and 21200)	16.	Hardware Kit (16SE7123 for 21201 and 21202)
17.	Hardware Kit (16CS7004 for 21211)	18.	Driver Tail Pipe Turndown (16SE4595)
19.	Passenger Tail Pipe Turndown (16SE4596)	20.	Driver Tail Pipe for Tips ZR2 (16SE4593)
21.	Passenger Tail Pipe for Tips ZR2 (16SE4592)		

If something is missing, call CORSA Tech Support at 440.891.099 or Toll Free: 1.800.486.0999

Removal Instructions

Factory Exhaust

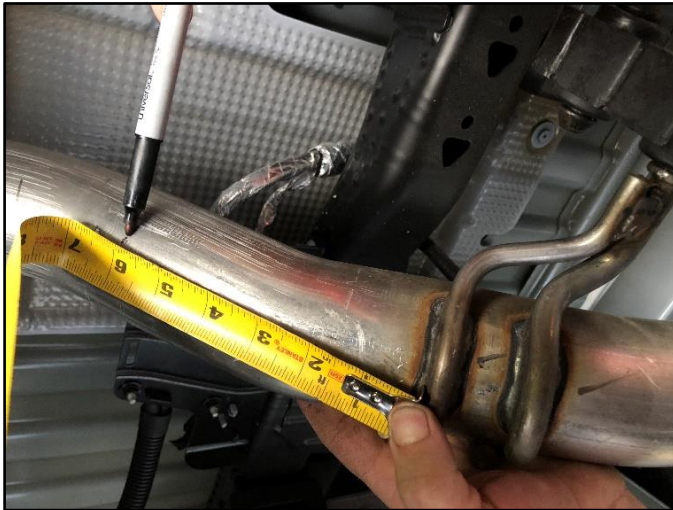

1. Mark a line 6" from the Hanger next to the muffler closest to the rear of the vehicle.



2. Place a Chain Style Cutter or similar around the exhaust pipe at the marked line location and cut the exhaust pipe.



3. Use a 13mm Socket & Ratchet or Wrench to loosen the spherical clamp on the factory Head Pipe.

Keep the factory Spherical Clamp in place for now.



4. Remove the Grommets from the factory Head Pipe hangers at in the front of the muffler/behind the flex pipe, using Grommet Pulling Pliers or similar.

The soap and water solution will aid in the removal of the hangers from the factory grommets.

Continued on Next Page...

Removal Instructions

Factory Exhaust



- 5.** Remove the Grommet from the Driver Tail pipe Hanger behind the Muffler, using Grommet Pulling Pliers or similar.

The soap and water solution will aid in the removal of the hangers from the factory grommets.



- 6.** Remove the Grommet from the Passenger Tail Pipe Hanger behind the Muffler, using Grommet Pulling Pliers or similar.

The soap and water solution will aid in the removal of the hangers from the factory grommets.



- 7.** Remove the front section of the factory exhaust system and set it in a safe place. You will remove the Spherical Clamp in Install Step 1.



- 8.** Loosen the factory flange on the Driver Tail Pipe using a 13mm Socket & Ratchet or Wrench.

A second person may be needed to assist with this step to support the remaining exhaust components or by using a jack stand or similar device.

Continued on Next Page...

Removal Instructions

Factory Exhaust



- 9.** Using a 13mm Socket & Ratchet or Wrench, remove the 2 bolts attaching the factory Grommet to the Driver Rear Frame Rail.



- 10.** Remove the factory Driver Tail Pipe section.



- 11.** Using a 13mm Socket & Ratchet or Wrench, remove the 2 bolts attaching the factory Grommet to the Passenger Rear Frame Rail.



- 12.** Remove the factory Passenger Tail Pipe and Wye section.

Continued on Next Page...

Removal Instructions

Factory Exhaust



13. Remove the factory Grommet from factory Driver Tail Pipe Hanger and reattach it to the Frame using a 13mm Socket & Ratchet or Wrench.

14. Remove the factory Grommet from factory Passenger Tail Pipe Hanger and reattach it to the Frame using a 13mm Socket & Ratchet or Wrench.

The soap and water solution will aid in the removal of the Factory Grommets.

This concludes the removal of the factory exhaust.

Removal Instructions

Factory Exhaust

If installing a kit that retains the Factory Bezels or for a ZR2/AT4, skip to the next page.

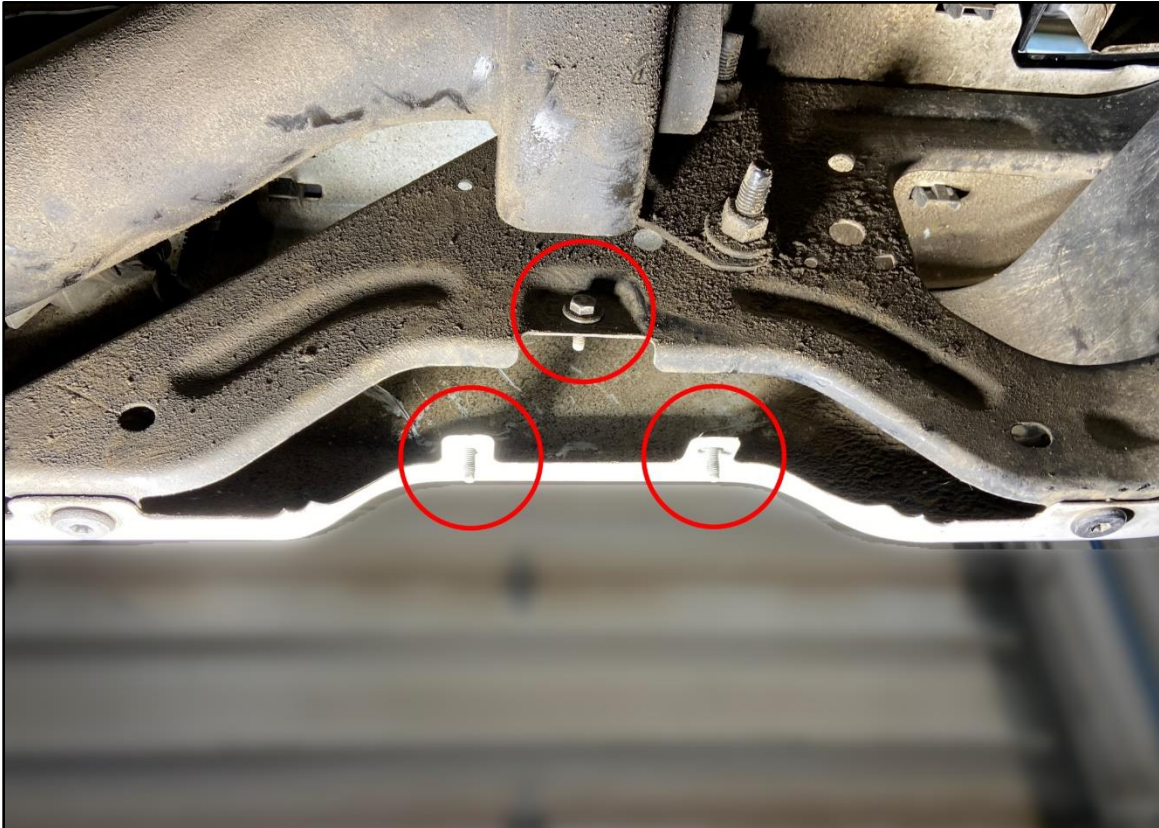

For clarity, the Factory Bezel is removed to show bolt locations.

The factory bezels are attached to the Bumper using 2 vertical bolts and to the Bumper Support Bracket using 1 horizontal bolt. Using a 10mm Socket & Ratchet or Wrench, remove these 3 screws from each bezel. The vertical bolt is behind the inlet opening, while the 2 vertical bolts are visible when looking into the exit of the bezel. These are removed by reaching into the Bumper cavity and above the bezel.

The hardware and bezels will not be used during the install process.

This concludes the removal of the Factory Bezels.

WARNING!!

It is recommended to apply anti-seize lubricant to the threads **ONLY** of the clamps and flange bolts. Failure to follow this procedure can cause nuts to seize on clamps and potentially destroy threads.

After applying anti-seize lubricant, be sure to thoroughly clean your hands. Anti-Seize lubricant may tarnish stainless steel.

All clamps should be tightened using a properly calibrated Torque Wrench. Using an impact gun will damage the clamp and reduce its ability to effectively seal the joint. It may also cause the joint to separate, thereby causing damage to your exhaust system and to your vehicle.

DO NOT SKIP THIS STEP

WARNING!!

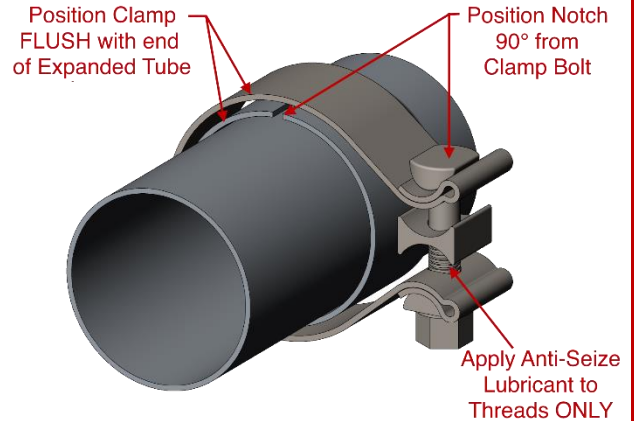

PRO TIP

Before installing, make a line from the end of non-expanded side of the pipes and muffler that is $1\frac{3}{8}$ in on $2\frac{1}{2}$ in tubing, and $1\frac{3}{4}$ in on 3 in tubing. These are CORSA's nominal joint overlaps. This will help during final adjustment. Do not be alarmed if the overlap varies slightly when the installation is complete. Any differences are caused by manufacturing variances from vehicle to vehicle and exhaust to exhaust.

Install Instruction

CORSA Exhaust

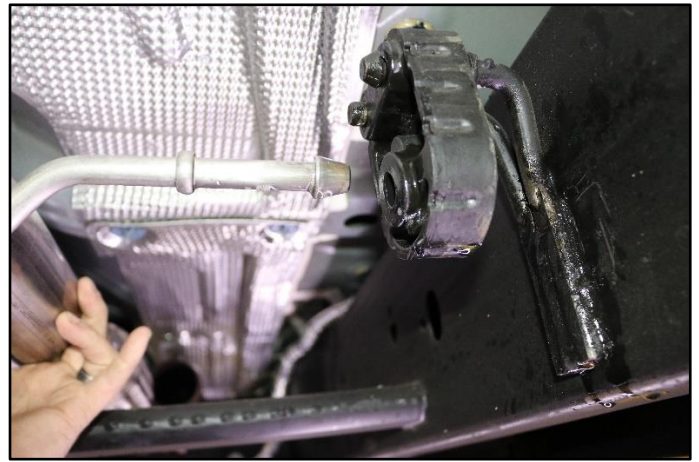

1. Locate the front section of the factory exhaust, and remove the Spherical Clamp by using a small flat screwdriver or similar and release the locking tab. Next, insert the Spherical Clamp onto the Head Pipe flare. Orient the Locking Tab facing the Flex Section.

2. Insert the CORSA Head Pipe Hanger into the factory Head Pipe hanger grommet.

The soap and water solution will aid with installing the hangers into the factory grommets.

Continued on Next Page...

Install Instruction

CORSA Exhaust

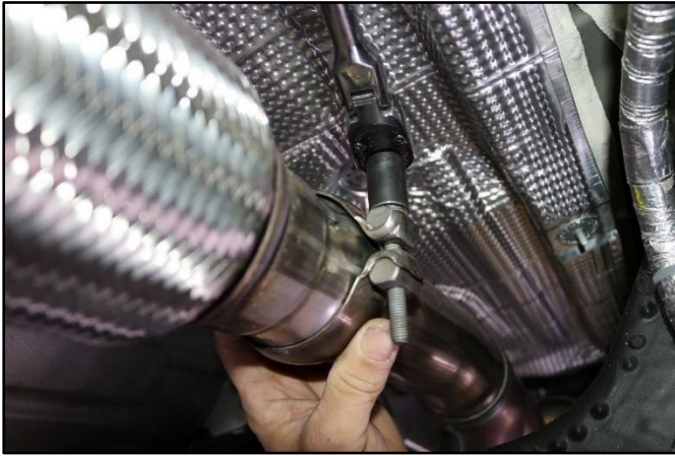

3. Insert the Spherical Flare on the CORSA Head Pipe onto the factory connection and ensure the connection is fully seated.

Using a 13mm Socket & Ratchet or Wrench, **SNUG** the spherical clamp.

DO NOT FULLY TIGHTEN at this time!

If installing Kits 21034 or 21043 (157in WB), slide the expanded end of the 157in WB Extension over the outlet of the CORSA Head Pipe. Next, slide a 3in Clamp over the joint and use a 15mm Socket & Ratchet or Wrench to snug the clamp. A second person may be needed to assist with this step.

DO NOT FULLY TIGHTEN at this time!



4. Slide a supplied 3.0in Clamp over the CORSA Head Pipe (or 157in WB Extension). Then slide the Expanded end of the CORSA Muffler over the outlet of the Head Pipe (or 157in WB Extension).
5. Support the rear of the CORSA Muffler with a Jack Stand or similar.

A second person may be needed to assist with this step.

Continued on Next Page...

Install Instruction

CORSA Exhaust

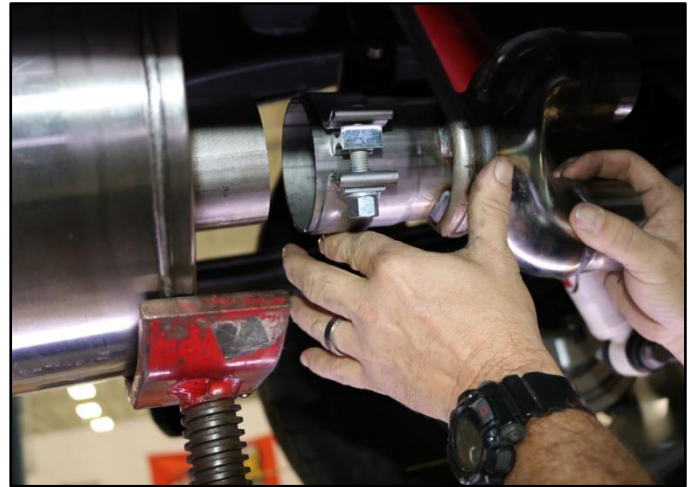

- 6.** Using a 15mm socket & ratchet or wrench, **SNUG** the 3in Clamp. **7.** Slide a supplied 3in Clamp over the CORSA Wye Assembly, as shown.

DO NOT FULLY TIGHTEN at this time!

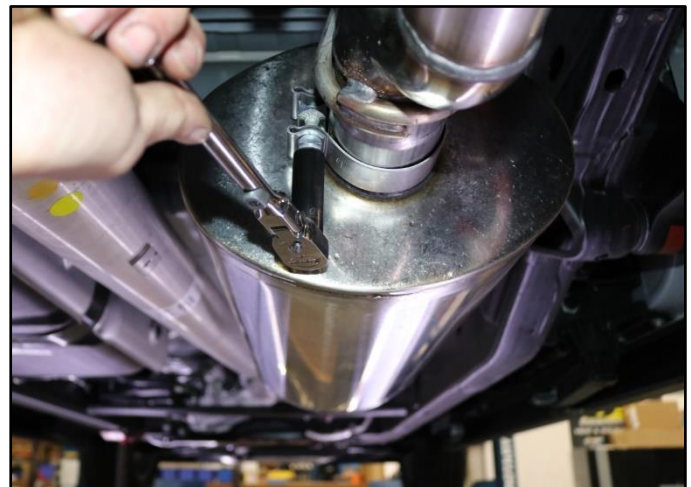

- 8.** Insert the hangers on the Wye Assembly into the Grommets and then rotate and slide the expanded end of the Wye Assembly over the Muffler outlet. **9.** Using a 15mm socket & ratchet or wrench, **SNUG** the 3in Clamp.

DO NOT FULLY TIGHTEN at this time!

The use of a soap and water solution will aid in the installation of the hangers and the grommets.

Continued on Next Page...

Install Instruction

CORSA Exhaust



- 10.** Lift the CORSA Driver Front Axle Pipe over the vehicle's rear axle and slide a supplied 2.5in clamp over the front Axle Pipe. Next, slide the Axle Pipe over the **TOP** Wye Assembly outlet.

Using a 15mm Socket & Ratchet or Wrench, **SNUG** the 2.5in Clamp.

DO NOT FULLY TIGHTEN at this time!

- 11.** Slide a supplied 2.5in clamp over the outlet of the CORSA Driver Front Axle Pipe. Next, lift the CORSA Driver Rear Axle Pipe into place and slide the expanded end over the Front Axle Pipe.

Using a 15mm Socket & Ratchet or Wrench, **SNUG** the 2.5in Clamp.

DO NOT FULLY TIGHTEN at this time!

A second person may be needed to assist with this step.



- 12.** Lift the CORSA Passenger Axle Pipe over the vehicle's rear Axle and slide a supplied 2.5in Clamp over the Axle Pipe. Next, slide the Axle Pipe over the **BOTTOM** Wye Assembly outlet.

Using a 15mm Socket & Ratchet or Wrench, **SNUG** the 2.5in Clamp.

DO NOT FULLY TIGHTEN at this time!

Continued on Next Page...

Install Instruction

CORSA Exhaust

The following steps show the Tail Pipes for Bezels and Turndown kits. The installation for the Tail Pipe for Tips follows the same process, except where the Tail Pipe is inserted into the Bezels.



- 13.** Insert the hanger on the CORSA Passenger Tail Pipe into the Grommet and insert the Tail Pipe outlet into the Factory Bezel opening.

The use of a soap and water solution will aid in the installation of the hangers and the grommets.



- 14.** Slide a supplied 2.5in Clamp over the Passenger Tail Pipe. Next, rotate the Tail Pipe into position and slide the Expanded end of the Tail Pipe over the Axle Pipe.

SNUG the Clamp with a 15mm Socket & Ratchet or Wrench.

DO NOT FULLY TIGHTEN at this time!



- 15.** Repeat the process for the Driver Tail Pipe.

If installing kits that retain the Factory Bezels or ZR2 Turndown Kit, skip ahead to Step 19.

Continued on Next Page...

Install Instruction

CORSA Exhaust

Continue with below installation steps if installing kits containing Tip Assemblies.

- 16.** Locate the CORSA Tip Assemblies and slide a supplied 2.5in Clamp over the Tip Assembly. Next slide the Tip assemblies over the Tail Pipes, with the CORSA etch on top.
- 17. SNUG** each Clamp with a 15mm Socket & Ratchet or Wrench.

DO NOT FULLY TIGHTEN at this time!



- 18.** Verify the Tips are straight across and even. There should be approximately the same 1/2in gap all the around the Tips and Bezel openings. To adjust, you may need to loosen the Tail Pipe Clamps from Steps 14 and 15.

A second person may be needed to hold the Tips in the correct position while the clamps are being snugged.

- 19.** Starting at the front, verify the Hanger sections are centered in the Grommets and parallel with the ground. Verify the Muffler is close to level and all connections are straight. Verify the clearance around the Tips or Bezels. Next, starting at the Spherical Clamp and using a torque wrench, tighten all clamps to 45ft-lbs. Torque the Frame Mounted Hangers to manufacturer specifications.

A second person may be needed to hold the components in the correct position while the clamps are being torqued.

This concludes the installation of the CORSA Exhaust.

Before Road Testing

1. Start engine, leaving the transmission in park and/or securing the parking brake.
2. Make sure to look and listen for any unusual noises. Repair problems if needed.
3. Immediately following the installation of your exhaust system, you may experience a trace of smoke after initial start-up. Do not be alarmed. The smoke is caused by the burning of a small amount of forming oil residue used in the manufacturing process.
4. It is strongly suggested that the alignment of the components and all clamps be checked and re-torqued after road testing the vehicle and once the system has fully cooled.
5. During cold weather start-ups, you may experience an exhaust sound that is deeper and louder in tone than usual. This is temporary and will diminish to normal levels once your engine has reached its normal operating temperature.