



dB Performance Exhaust System Installation
Cat-Back Exhaust System
Single Side Exit w/ 4" Slash Cut Tip
2005-06 GMC Sierra Denali 6.0L CCSB
Part # 24240

Please take time to read and understand these installation instructions.

We recommend that the installation of this system be performed by a qualified service center or professional muffler installer who has the necessary equipment, tools and experienced personnel. However, if you decide to perform this install, the use of a hoist and an additional person will be required.

CAUTION: Never work on a hot exhaust system. Allow time for the vehicle to cool. Always wear eye protection when working under a vehicle.

Please confirm that all parts are present before beginning the factory exhaust system removal and dB Performance Exhaust system installation.

Recommended Tools:

- Safety Glasses
- 15mm Wrench & Deep Socket
- Torque Wrench
- Soap & Water Solution
- Saw or Chain-Style Pipe Cutter

Part #24240

Bill of Materials:

- 1- Muffler Assembly (16SE2025)
- 2- dB Slash Cut Tip (16SE3023)
- 3- Intermediate Pipe Assembly (16SE4296)
- 4- Tailpipe Assembly (16SE4300)
- 5- Hardware Kit (24TI7201)

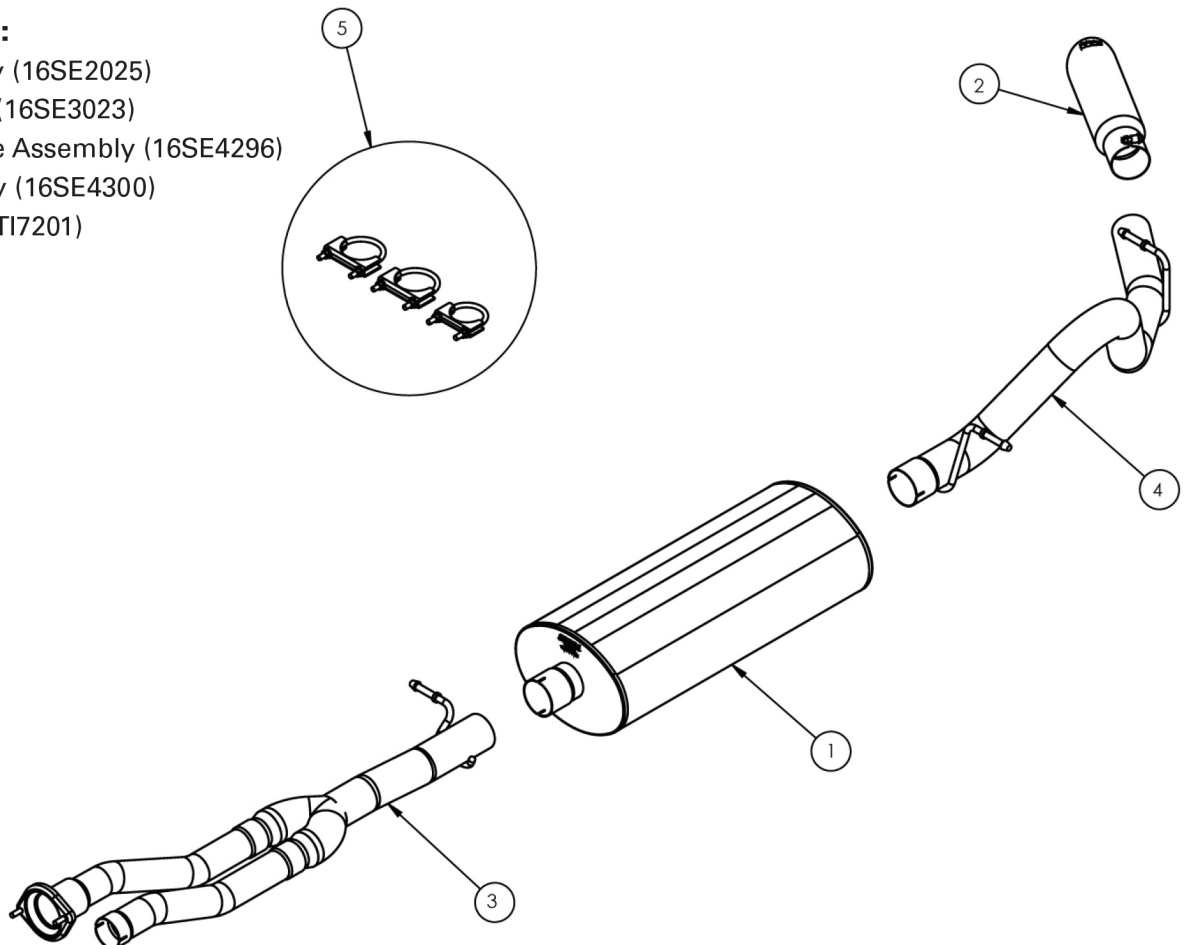

Stock Removal Instructions:

- 1) Locate the Y after the muffler. Use a saw or chain-style pipe cutter to cut the pipe (**See Fig. A**).
- 2) Unbolt intermediate-to-header pipe flange using 15mm socket (**See Fig. B**) and remove both bolts. Now remove clamp from other pipe with a 15mm wrench. (**See Fig. C**). Be sure to support muffler to prevent injury. Use lubricant to loosen bolts if necessary.
- 3) Next, remove hanger from rubber isolator located on the Tail Pipe and remove the Tail Pipe from the vehicle (**See Fig. D**).

NOTE: Use soap/water solution on all hangers and rubber isolators to facilitate removal.

- 4) Remove Muffler Extension Pipe and Muffler hangers from rubber isolators (**See Fig. E**). Be sure to keep the rubber isolators.



FIG. A



FIG. B



FIG. C



FIG. D



FIG. E

Installation of dB Performance Exhaust System:

NOTE: The supplied double edge clamps in this system will crush and permanently deform the exhaust piping as they are tightened. DO NOT tighten these clamps any more than is necessary to lightly hold the exhaust components in place, until the very end of this installation process. It will be difficult or impossible to make any positional or rotational adjustments to the exhaust system after these clamps have been tightened down.

VERY IMPORTANT: Align all clamps so that the open edge of the clamp bracket is parallel and aligned with the notch in the pipe, and the outside edge of the clamp bracket is approximately 1/8" from the end of the pipe expansion. (See Fig. 1) Failure to properly position or orient the clamps could result in a weak clamping load, or even a potential leak at the clamp joints.

IMPORTANT: Make sure that the small drain holes in the muffler are facing down when the muffler is installed. (See Fig. 2)

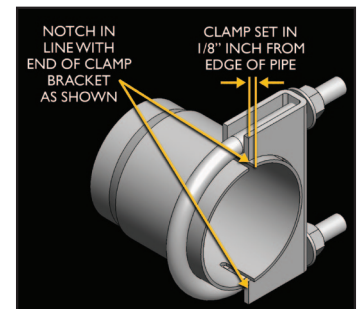

FIG. 1



FIG. 2

Installation of dB Performance Exhaust System:

- 1) Locate Intermediate "Y" Pipe (Dual into one pipe) (See Fig. F). Position Intermediate Pipe to the factory flange and snug-fit flange bolts. Slide a supplied 2.5" clamp over the expanded or "slotted" end of the pipe and snug-fit the clamp.
- 2) Next, slide Intermediate Pipe into muffler and slide a clamp over muffler inlet (expanded or "slotted" side). Snug-fit the clamp (See Fig. G). Do not tighten clamp at this time.
- 3) Locate the Tail Pipe (See Fig. H) and slide the Tail Pipe inlet over the Muffler outlet (See Fig. I). Slide a clamp over the Tail Pipe inlet. Snug-fit the clamp but do not tighten clamp at this time.



FIG. F



FIG. G

IMPORTANT NOTE: When tightening flange bolts, alternately tighten each bolt so the spacing is even all the way around the flange connection. Uneven tightening may result in an exhaust leak.

- 4) Locate the dB Performance slash cut tip, which has a clamp built into it. Slide the clamp end of the tip onto the end of the tailpipe. (See Fig. J) Rotate the tip until the dB Performance logo is centered on the top side of the tip. (See Fig. K) Snugly tighten the clamp as shown using a 15mm socket and ratchet, making sure to only tighten the clamp enough to hold the tip in place on the tailpipe. (See Fig. L)



FIG. H



FIG. I



FIG. J



FIG. K

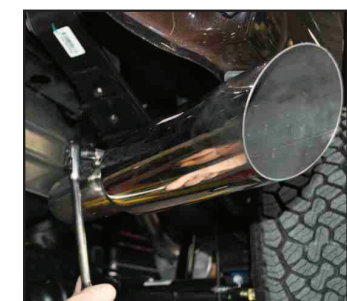

FIG. L

- 5) Visually inspect the exhaust system position, tip alignment, clamp orientation and position, and exhaust pipe clearance. Make any necessary adjustments at the slip joints.



dB Performance Exhaust System Installation
Cat-Back Exhaust System
Single Side Exit w/ 4" Slash Cut Tip
2005-06 GMC Sierra Denali 6.0L CCSB
Part # 24240

- 6) It is **STRONGLY SUGGESTED** that all clamps be checked and re-tightened (if necessary) to the recommended torque after initial road testing of the vehicle, as thermal cycling has occurred on the system. Please wait until system has fully cooled to conduct this process.

NOTE: During cold weather start-ups, you may experience an exhaust sound that is deeper and louder in tone than usual. This is temporary and will diminish to normal levels once your engine has reached its normal operating temperature. **NOTE:** Immediately following the installation of your exhaust system, you may experience a trace of smoke after initial start-up. **DO NOT** be alarmed. The smoke is caused by the burning of a small amount of forming oil residue used in the manufacturing process.