

Continental™

660L



A popular sized container, the Continental™ 660 litre has a deceptively large capacity in a small footprint. Its slim configuration allows it to fit through a standard doorway, making it ideal for indoor storage or secure collection areas.



Part of

Egbert Taylor

Continental™ 660L

Internally welded seams prevent internal corrosion, whilst the hard wearing galvanised steel body and base make for a durable, long lasting container that delivers exceptional lifetime value when compared to plastic or alternative steel containers.

The Continental™ 660 litre waste container is also available with a number of body, handling and lifting options as well as a wide range of body and lid colours - increasing the versatility of your container.



Features

Featured as standard on all Continental™ 660's:

- EN840 compliant
- Internally seam welded
- Hot dip galvanised body
- Welded comb bar
- Side handles
- 20mm top frame
- 2 x swivel castors & 2 x braked castors
- Roto moulded lid

Options

- DIN points
- Custom embossing
- Drop front / drop back panel
- Tag safe
- Drain plug options
- Different handle options
- Different lid types & apertures
- Variety of lid colours
- Powder coated body colour options
- Locking options
- Security solutions
- Sound deadening

Technical Details

Height:	1320mm	Capacity:	660 litres
Width:	1250mm	Empty Weight:	81kg
Depth:	720mm	Castors:	160mm

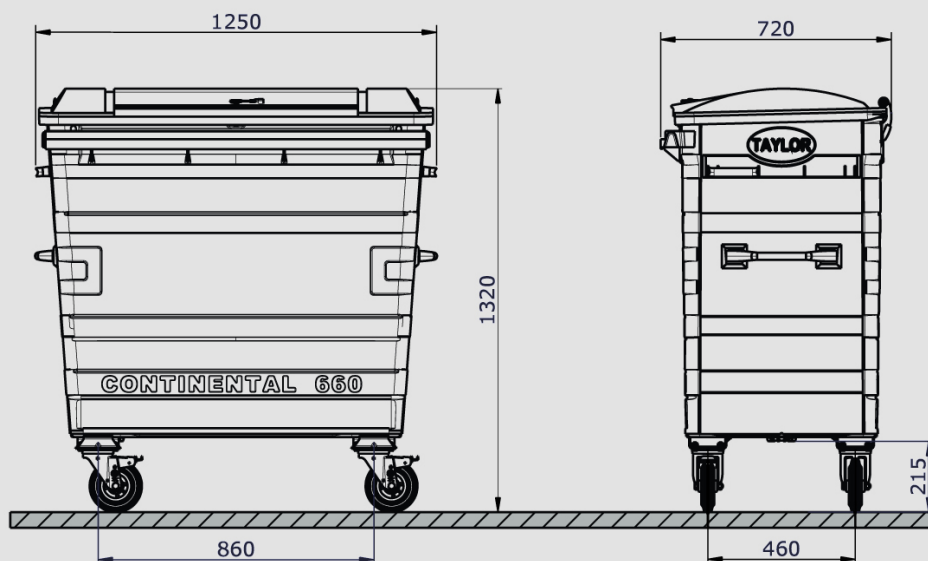

Continental™ 660L Datasheet / UK EN

Talk to us

+44 (0)1299 251 333

Email us

info@egberttaylor.com

Visit us online

www.egberttaylor.com

Egbert H. Taylor & Co Ltd, Oak Park, Ryelands Lane, Elmley Lovett, Droitwich, Worcestershire, WR9 0QZ, UK

Egbert H. Taylor & Co Ltd is a limited company registered in England and Wales. No. 00718441. Registered Office as above.