

RETROAKTIV

HLFO

UTILITY MODULATION SOURCE

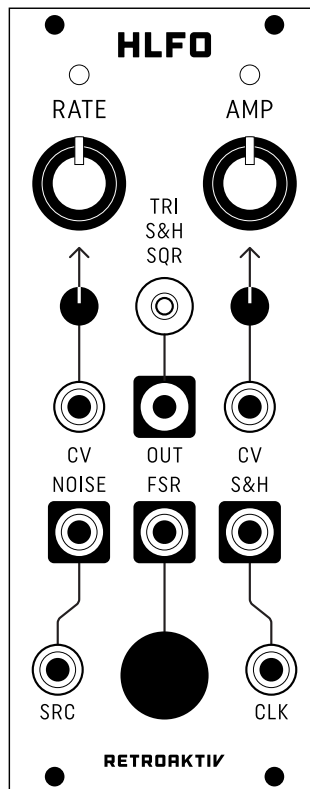

OPERATION MANUAL

FRONT PANEL CONTROLS

RATE (Large Dial) - This adjusts the rate of the triangle and square LFO.

RATE LED - Indicates the rate of the triangle/square LFO.

RATE (Trimmer) - This adjusts the RATE CV amount. When no plug is inserted into the RATE jack, this controls the amount that the FSR will control the rate of the LFO. With a plug inserted, this controls how much the external CV affects the LFO rate.

TRI/S&H/SQR - This switch selects the output waveform of the HLFO. In the center position, the Sample & Hold output will be routed through the LFO VCA and inverted.

NOISE - This output provides a noise source. The noise output is +5V to -5V.

SRC - Sample & Hold source input. The internal sample and hold circuit is normally sampling the internal noise source when nothing is plugged into the SRC jack. Plugging into SRC will disconnect the noise, and the external signal will be used as the sample source.

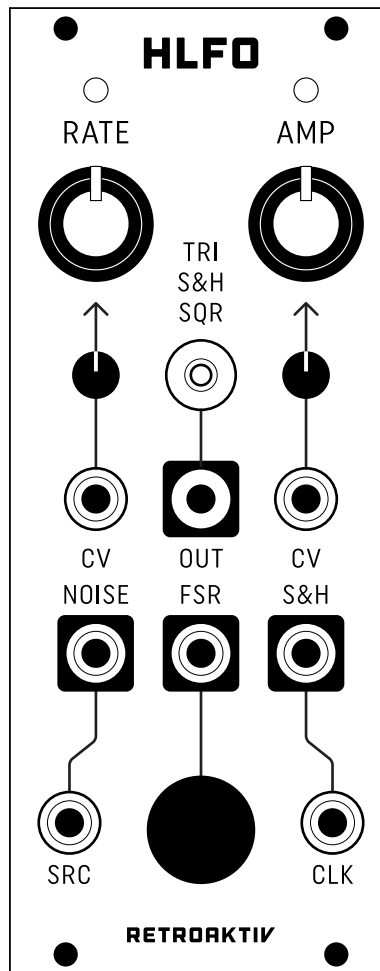

AMP (Large Dial) - This adjusts the output amplitude of the LFO signal at the OUT jack.

AMP LED - Indicates the amplitude of the LFO OUT signal.

AMP (Trimmer) - This adjusts the AMP CV amount. When no plug is inserted into the AMP jack, this controls the amount that the FSR will control the amplitude of the LFO. With a plug inserted, this controls how much the external CV affects the LFO amplitude.

S&H - This is the output of the internal sample & hold circuit. The S&H signal can be accessed here, even when other output waveforms are selected at LFO OUT.

FSR - FSR Output. Pressing on the FSR will generate a voltage from 0 to 5V, based on how much force is being used on the sensor pad.

CLK - Sample & hold clock. Use this input to clock the S&H circuit. Incoming clocks should be a square wave with an amplitude of at least 3Vpp.

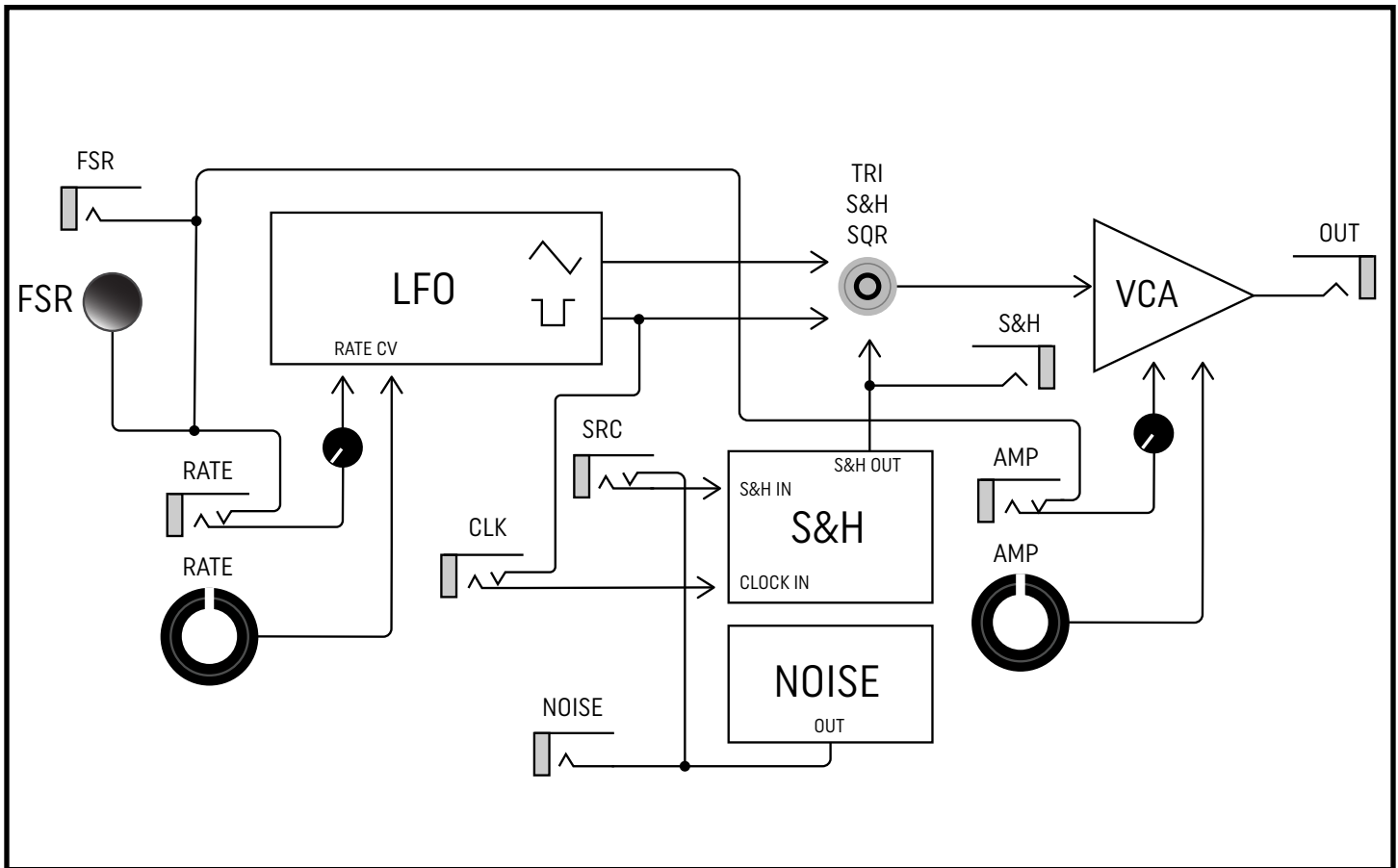

Figure 2 - HLFO Block Diagram

POWER REQUIREMENTS

HLFO is powered by +/- 12VDC and uses a 10 pin (2x5) IDC power cable. The **+12V** rail consumes **24mA** of current. The **-12V** rail consumes **8mA** of current.

REAR PANEL CONNECTIONS

The HLFO module PCB contains additional inputs and outputs, allowing for bussing signals between modules from the rear panel. This can be useful for normalizing modules in a rack, or creating auxilliary inputs and outputs. J10 connections are as follows:

- Pin 1 - Force sensor output (0 to 5V)
- Pin 2 - CLK Out - (10V to -10V)
- Pin 3 - Sample & hold output (-5V to +5V)
- Pin 4 - LFO Output (Post VCA)
- Pin 5 - External S&H source input (-10V to +10V) [Use jumper J11 to activate]
- Pin 6 - Noise output

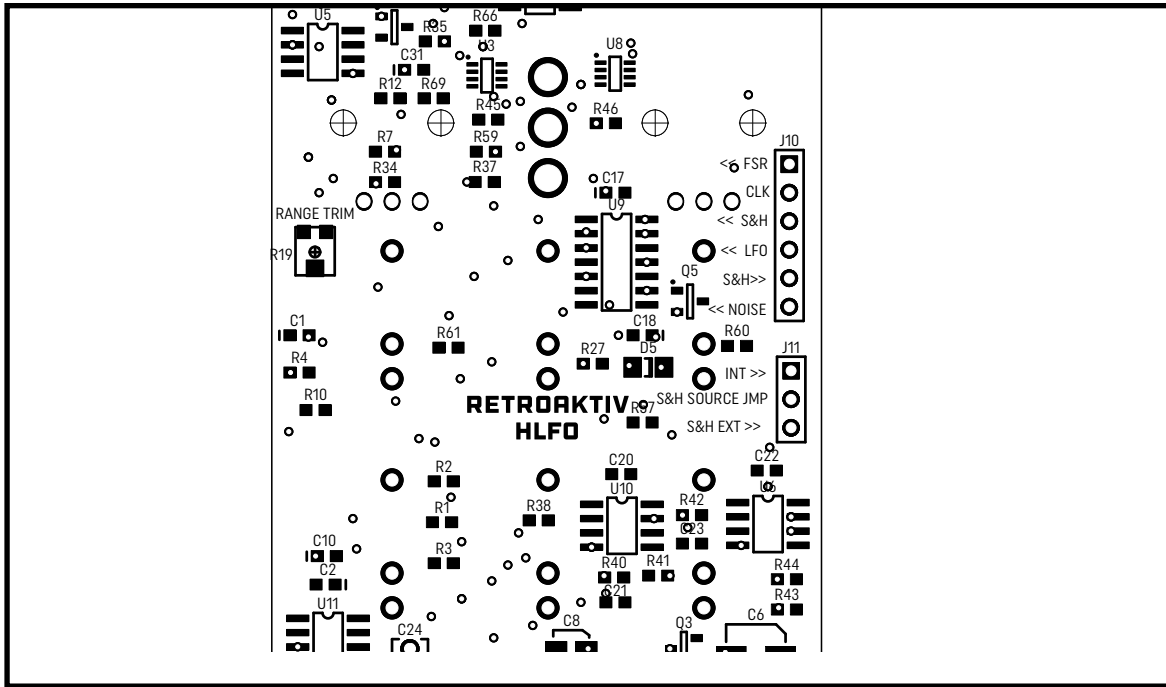

Figure 3 - Aux Connections & S&H Source Jumper

S&H SOURCE JUMPER (J1) - The HLFO produces the default S&H waveform by sampling the module's internal noise source. The S&H input signal can be normalized to an external signal instead. To do this, the external signal must be connected to J10, pin 5 (S&H EXT INPUT), and J11, pins 2 & 3 must be jumpered. For normal operation, jump J11 pins 1 & 2.

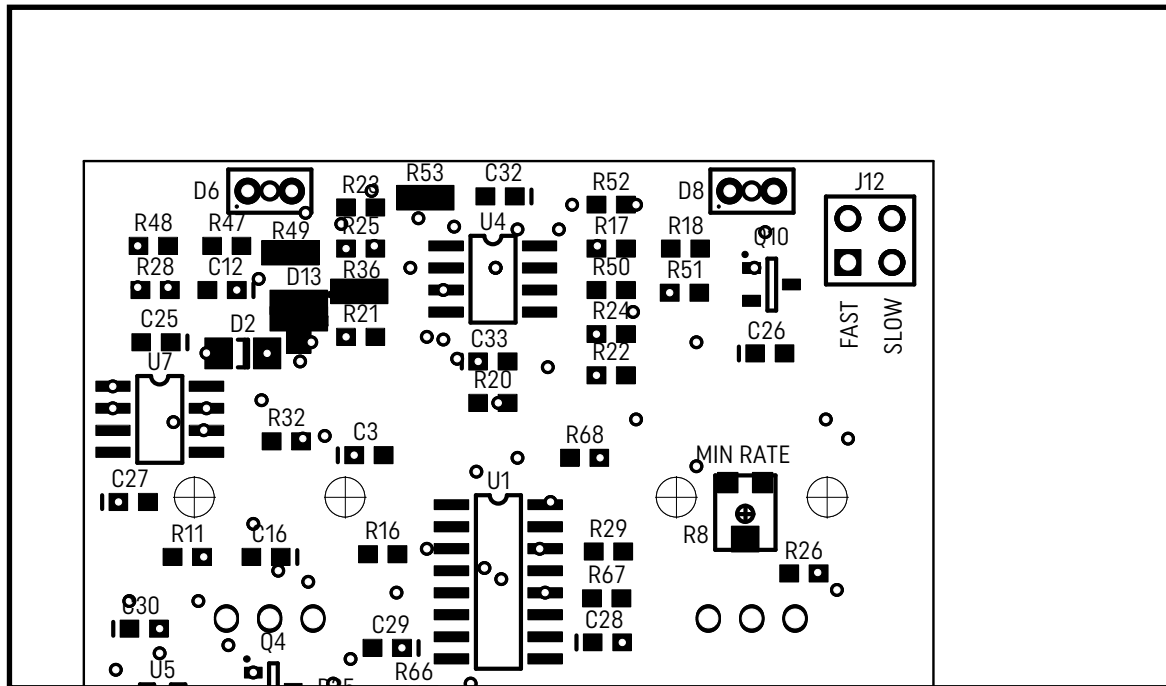

Figure 4 - Speed Range Jumper & MIN RATE Trim

RATE RANGE JUMPER (J12) - The HLFO has 3 speed range settings. When the FAST jumper setting is selected, the minimum speed is about .25Hz, and the maximum speed is 125Hz. With SLOW setting selected, the minimum speed is about .025Hz (Period of about 45 seconds) and the maximum speed is about 10Hz. If both FAST and SLOW are jumpered, the HLFO is capable of periods of over 1 minute.

MIN RATE TRIM - The HLFO's minimum rate can be dialed in using the MIN RATE trimmer. If this trim is set to 0, the HLFO will full stop oscillating at the minimum RATE setting.

RANGE TRIM - The range trim should be set to minimum in most cases. If the maximum rate is reached before the RATE pot is at its max, use the RANGE TRIM to stretch the useful range of the RATE pot to its maximum.

SIGNAL LEVELS

NOISE output level - +5V to -5V

LFO TRI output level (max) - +3V to -3V

LFO SQR output level (max) - +5V to -5V

S&H output level (max) = S&H SRC input level (max)

CLK input - Threshold to trigger S&H is +5V. Input tolerant to +/-10V signals

SRC input - tolerant to +/-10V signals

FSR output - 0 to +5V

RATE CV - Input tolerant to +/-10V signals

AMP CV - Input tolerant to +/-10V signals

DIMENSIONS

Width = **10HP**. Front panel = **128.5mm x 50.8mm**. Depth = **22mm**.