

# FiTech™ Fuel Injection

## Fuel Command Center (#40003) Installation Instructions

*The Fuel Command Center is designed to be used only with FiTech EFI Systems that include the Pulse Width Modulation (PWM) feature.*

The FiTech Fuel Command Center is the ultimate in a fuel delivery system. It not only is the most efficient way to supply fuel to your FiTech EFI system, it also greatly simplifies the installation process. It is a returnless system which effectively eliminates the need for a return line.

It uses your stock fuel tank, stock carbureted fuel pump, and stock inlet fuel line. You simply disconnect the fuel line that runs from your pump to your carburetor and replace it from the pump to the Fuel Command Center which can be mounted in the engine compartment. The only additional plumbing required is to run a line from the Fuel Command Center to the inlet port on the FiTech Go System EFI. Most nec-

essary hose, hose ends, and fittings are supplied.

The Fuel Command Center contains an internal float mechanism that shuts off the fuel flow once the sump tank is filled. A 340 L/PH high pressure fuel pump is submerged in the fuel in the sump tank. A submerged pump runs quieter and cooler and lasts longer than external fuel pumps.

The Fuel Command Center is capable of providing enough fuel for engines producing up to 800 HP but is still suitable to be used on engines making as little as 200 HP.

**NOTE:** It is very important that a carbureted fuel pump is used to feed the Fuel Command Center. (8 PSI maximum).

### 40003 Kit Contents

- (1) Sump Tank Assembly
- (1) 340 L/PH Fuel Pump
- (1) 30 Micron Inline Fuel Filter
- 5' of EFI -06 Fuel Hose (Push Lock)
- (2) -06 AN 90° Hose Ends (Push Lock)
- (3) -06 AN Straight Hose Ends (Push Lock)
- (1) -06 AN 45° Hose End (Push Lock)
- (4) 5/16-18 x 1" Hex Head Bolts
- (4) 5/16 Flat Washers
- (4) 5/16-18 Lock Nuts
- (1) 0-15 PSI Fuel Pressure Gauge
- (1) 0-100 PSI Fuel Pressure Gauge
- (1) Hose Clamp

### Plumbing Schematic for Fuel Command Center - Fuel Delivery Kit #40003

Figure 1

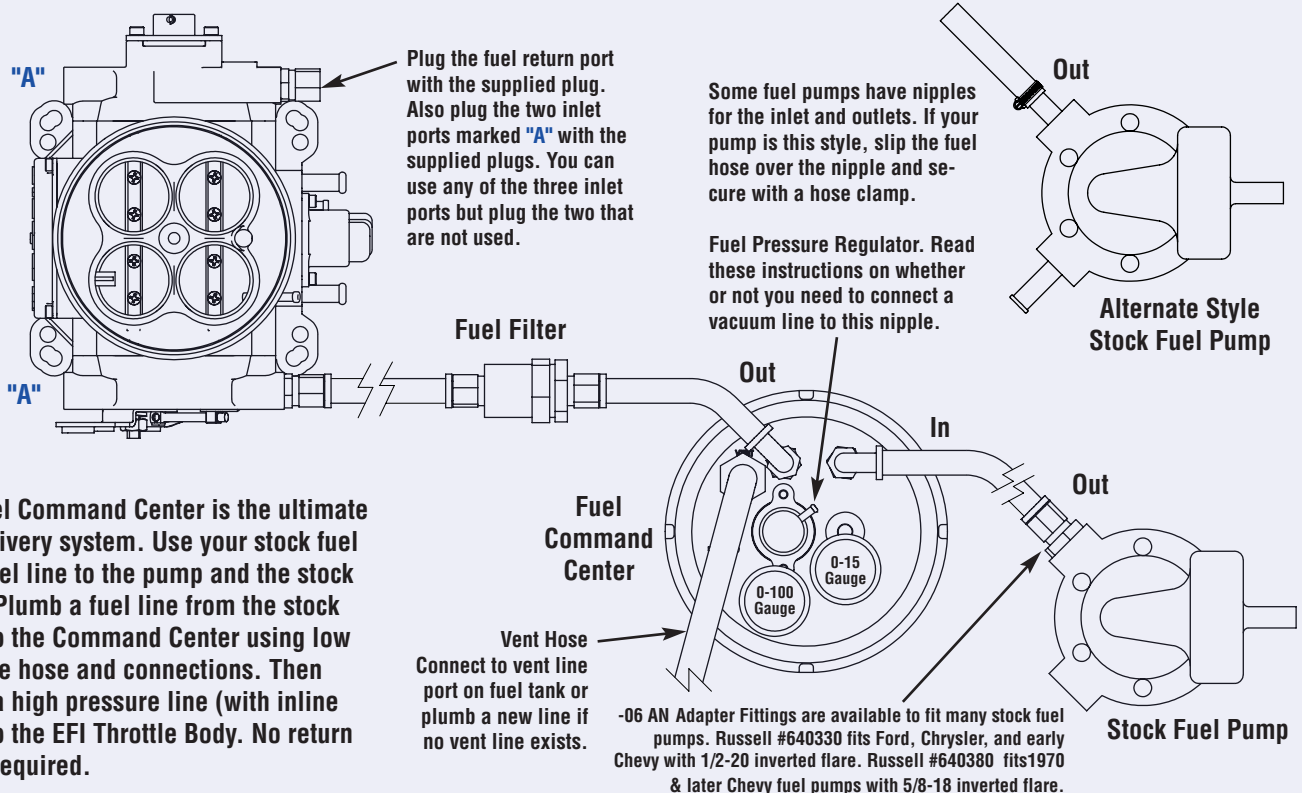

The Fuel Command Center is the ultimate fuel delivery system. Use your stock fuel tank, fuel line to the pump and the stock pump. Plumb a fuel line from the stock pump to the Command Center using low pressure hose and connections. Then plumb a high pressure line (with inline filter) to the EFI Throttle Body. No return line is required.

## Installing the Fuel Command Center

Locate a suitable spot to install the Fuel Command Center. It can be mounted on the firewall, inner fender panel, or down on the frame if you have room. Five feet of fuel hose is supplied with this kit so the Center needs to be within five feet of the throttle body. Make sure you choose a position where the fuel hose can be routed without getting too close to the exhaust manifolds or any moving parts.

The supplied inline filter will be installed in the fuel line that runs from the Command Center to the EFI throttle body, so plan the routing of that line so there is a place to conveniently install the filter.

You must also install a conventional carburetor style (low pressure) filter between the fuel pump and the Fuel Command Center to avoid dirt particles clogging the needle and seat inside the Command Center.

The Command Center must be installed in the upright position. This is important for proper operation.

Using the two mounting brackets that secure the Command Center in place as templates, mark spots to drill four holes. Drill four 11/32" diameter holes and secure the Command Center in place with the supplied bolts, nuts and washers. If your mounting surface is not flat, use washers or spacers when mounting the Command Center so that it is in the vertical position.

Determine your necessary hose lengths. You will need three hose lengths. One will run from the stock fuel pump to the Command Center with a user-supplied filter.. A second will run from the Command Center to the Filter and the third runs from the Filter to the fuel injection Throttle Body. Cut the ends of the hose with a very sharp blade and make sure the end cut is square and clean. To install the hose ends, clamp the hose end in a vise using something to protect the finish. Do not overtighten the vise and damage the hose end. Coat the hose end and hose liberally with WD-40 or some other lubricant. Push the hose onto the hose end making sure it fully bottoms out. Do not mix the supplied hose or hose ends with any other brand of hose or hose ends.

Your Command Center Kit includes several styles of push lock style hose ends. We recommend the following configuration of these hose ends. You may find that your particular installation may require a different configuration. If you need additional hose or hose ends you can order them direct from FiTech.

### Hose and Hose Ends Usage

The hose that goes from the Command Center to the Fuel Filter should have a 90° hose end on the Command Center end and a straight hose end on the filter end. The hose that runs from the Filter to the throttle body should have a straight hose end on the filter end and a 45° hose end on the throttle body end.

The hose that goes from the stock fuel pump to the Command Center should have a straight hose end on the fuel pump end and a 90° on the end that feeds the Command Center. This is just a suggested starting point. Carefully plan your plumbing and fitting requirements. The FiTech throttle body has three inlet ports so pick the one that best suits your layout. Also remove the supplied return fitting and plug the return port on the throttle body with the supplied port plug. See Figure 4 on last page of these instructions.

### Command Center Vent Port - IMPORTANT

The Vent Port is a critical part of the installation and these instructions **must** be followed for a safe and proper operation of the system. The Command Center has a Vent Port complete with a Rollover Valve. A fuel rated hose or hard line must be routed from the Vent Port back to the fuel tank. Many vehicles are already equipped with a vent line to the tank. You can tee into the existing line if your vehicle is so equipped. **DO NOT** run a vent line from the Command Center to the OPEN AIR in the engine compartment or pointed to the ground or to the air cleaner. Fumes from the Vent Port are dangerous and must be properly routed. You may need to change the pipe fitting on the Command Center to suit the line diameter you use. If no existing vent line to the tank exists, you must plumb your new line to a point above the fuel level of the tank at the top or in the filler neck. **Proper routing of a vent line is not an option. It is a mandatory part of the installation.** If the vent is not properly routed to the gas tank FiTech cannot be responsible for any fires or other issues resulting from improper vent routing or failure to follow these instructions.

### Determining Inlet Port On Throttle Body

The Fuel Command Center is a returnless system. On your FiTech Go EFI System throttle body there are four fuel ports. (See figure 4) One is marked "Return." Plug that port with one of the plugs that came with the EFI kit. Select any one of the remaining three ports as your inlet port. Install one of the supplied -06 AN fittings in the port that you have selected to use and install the supplied plugs in the other two ports. You will have one -06 AN fitting left over. (This fitting is required when using the 40005 Fuel Delivery Kit which is a return style system.)

### Grounding the Command Center

Run a ground wire from the negative (-) terminal on the Command Center to a metal grounded part of the car. If your battery is close to the Command Center you can attach the wire directly to the battery ground cable. Without a good ground the pump will not run. A self tapping metal screw may be needed to attach the wire end to a sheet metal part of the car. Make sure any paint is removed

so the ground wire makes contact with bare metal.

### **Wiring the Command Center**

Your FiTech EFI system has a large orange wire that is part of the group of wires from the ECU. This wire has to be connected to the positive (+) terminal on the Command Center. Do not connect this wire to Command Center after the proper length has been determined. The system must be primed before this wire is connected otherwise you risk damaging the pump. Place some tape over the exposed end of the wire to avoid accidental contact with a metal surface.

### **Plumbing the Stock Fuel Pump to the Command Center**

Some stock pumps have a steel tube as the pump outlet. If your pump is so configured you can slip one end of the supplied -06 hose over the tube and secure it with a hose clamp. Other style pumps have a threaded port for the outlet. If the port has a fitting that has a barbed end where a stock fuel hose is clamped to it, you can use that fitting. If your pump has a hard line coming from the outlet port of the pump, remove the threaded fitting and replace it with a steel adapter fitting. There are two fuel pump adapter fittings available. They both provide a male -06 AN thread that you can connect a fuel hose to with one of the supplied -06 hose ends. The fitting with 1/2-20 threads fits Ford, Chrysler and pre-1970 Chevys. The fitting with 5/8-18 threads fits 1970 and later Chevys. Edelbrock pumps may require a special adapter fitting (available from Russell Performance).

If your pump has an outlet port with 3/8-NPT or 1/2-NPT ports you will need to acquire an adapter fitting with those threads on one end and -06 AN threads on the other. Adapter fittings are available from any fitting supplier such as Russell, Earl's or Aeroquip.

### **Plumbing the Command Center to the Throttle Body**

You have previously determined the lengths required for the hoses from the Command Center to the Fuel Filter and from the Filter to the Throttle Body. Install those hoses.

The supplied fuel filter is light enough that it's weight can be supported by the fuel hose. However, you can secure it with an Adel clamp or a tie wrap if desired. (Clamp or tie wraps are not included in this kit.)

### **Fuel Pressure Regulator**

The Command Center has a built-in fuel pressure regulator mounted on the top. This regulator is not adjustable but is pre-set to provide 58 PSI of fuel pressure to the EFI system. The regulator has a vacuum nipple on it. When the Command Center is used with a Fitech Go EFI System, this nipple is left open unless you are using the Command Center on an engine with a blow through su-

percharger or turbocharger. In that case a vacuum hose should be run from the regulator to non-ported vacuum nipple on the throttle body. See Figure 2.

The Command Center can be used with any fuel injection system. Depending upon the design of the unit being used, different connections need to be made to the vacuum nipple on the regulator. If the throttle body in the system you are using has the injectors under the throttle plates, you need to connect a vacuum hose to a ported nipple on the throttle body. If the injectors are above the throttle plates, leave the nipple open. On a port injection system where the injectors are in the manifold, connect a vacuum line to a ported nipple on the throttle body. On an engine with a Roots supercharger a vacuum connection should be made between the regulator and the throttle body if the injectors are under the throttle blades. If the injectors are above the throttle blades (which includes FiTech EFI systems) then leave the nipple port on the regulator open.

Note that 43.5 PSI (3 BAR) regulators are available from FiTech when the Fuel Command Center is used with other aftermarket EFI systems that require this type of regulator.

### **Fuel Pressure Gauges on Sump Tank**

The inlet gauge will show you the fuel pressure coming from your stock fuel pump. Do not use a pump that puts out more than 8 PSI. If your input reading is more than 8 PSI you will need to install a fuel pressure regulator between the fuel pump and the Command Center. The outlet gauge will show you the fuel pressure being supplied to the EFI which will be in the 58 PSI range.

### **Priming the Command Center**

Reconnect the negative battery cable. Do not connect the Fuel Command Center orange wire at this time. This is to avoid having the engine start during the priming procedure. Turn ignition key to the "ON" position and crank for ten seconds. Turn key to the "OFF" position and wait 30 seconds. Repeat this procedure a second time to fill the sump tank. This procedure allows your stock fuel pump to pump fuel to the Command Center but the Command Center is not pumping fuel to the EFI throttle body.

Check entire fuel system for any leaks before attempting to start the engine.

1. Be sure to install a carburetor style fuel filter between the stock fuel pump and the Fuel Command Center.
2. Do not connect orange wire until Command Center has been primed. CAUTION - Live wire.
3. Check all connections for leaks.

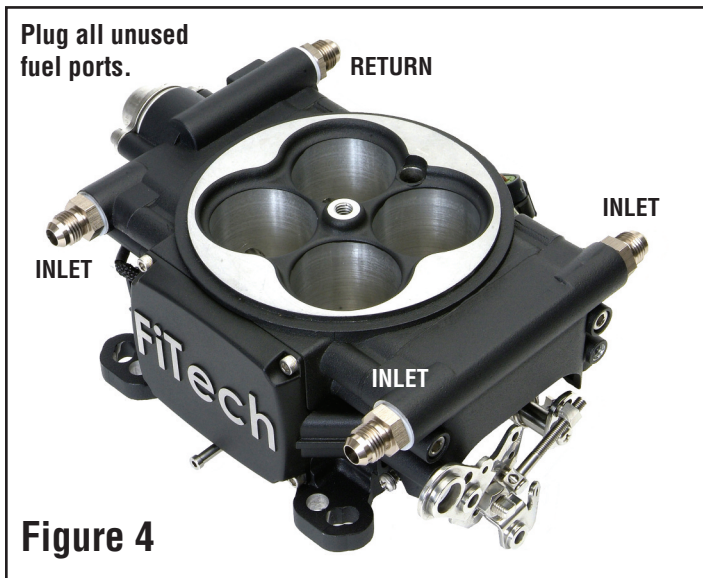
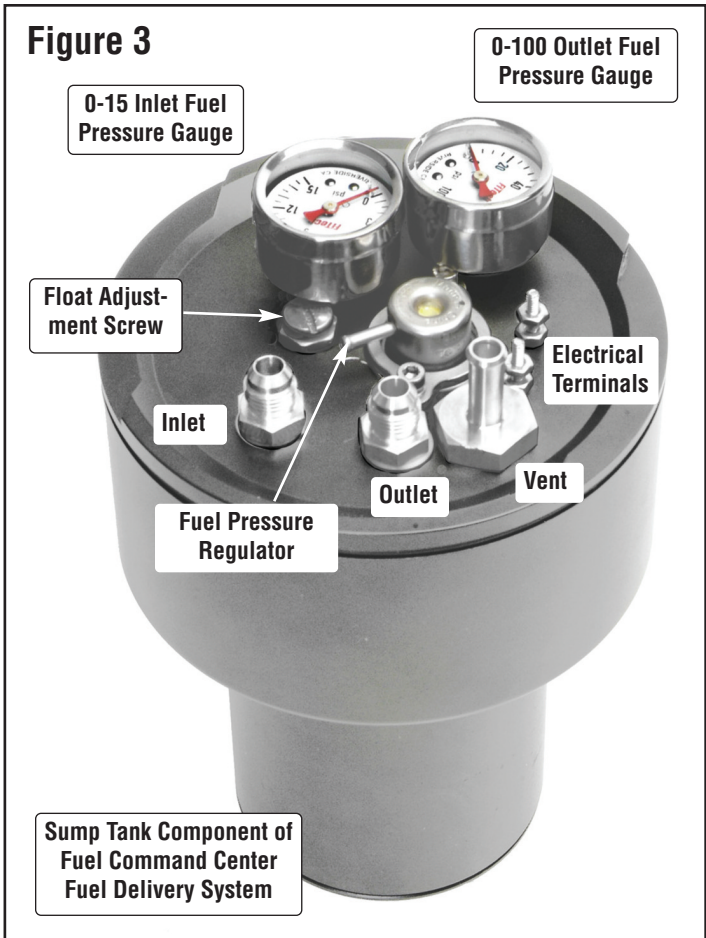
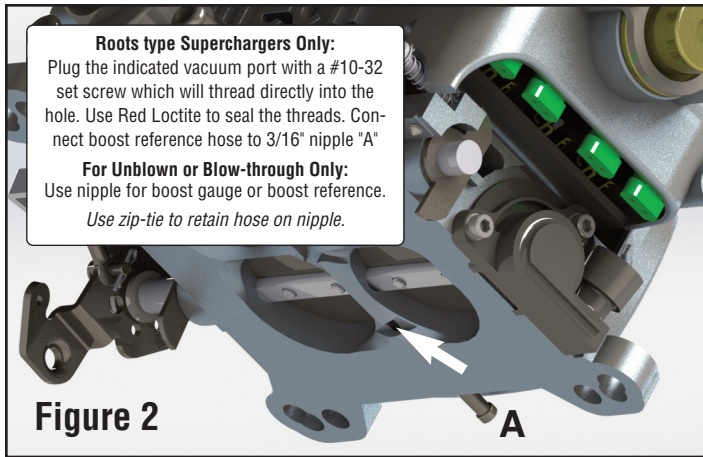

LEFT - The FiTech Go EFI Throttle Body has (3) Inlet Ports and (1) Return Port. The Return Port is plugged when using the Fuel Command Center.

**IMPORTANT NOTE:** The fuel tank on your vehicle must be vented to avoid pressure building up inside the tank. Do not attempt to install and operate an EFI system without a properly vented fuel tank.



**FiTech Fuel Injection**  
 12370 Doherty Street • Riverside, CA 92503  
 Tech Phone: 951-340-2624  
 www.FiTechEFI.com