



ADC Airbrush System

Single Action - Gravity Feed - PTFE Packings.

WARNING: Spray materials may be harmful if inhaled or allowed to come into contact with the skin or eyes. Consult the product label and material safety data sheet supplied for the spray material. Follow all safety precautions. **CAUTION:** Well Ventilated Area Required to remove fumes, dust or overspray. **Maximum Air Pressure 40 P.S.I.**



ADC Specifications:

- Single Action • Head Size .38mm * • 1/10th Ounce Gravity Cup • Needle Cap • Anodized Handle •

Working Pressures:

- Operating pressures 8-25 PSI; Maximum pressure 40 PSI.

Equipment Set-up:

The Airbrush is held in the same manner as a pen, with the index finger comfortably over the trigger.

1. Attach air hose to compressor and to airbrush.

Airbrush Operation:

1. Turn compressor on. Air will come out of the airbrush gun. Add airbrush color to the cup. Pull back on trigger to control quantity of airbrush color. The further you pull back the more color you will spray.
2. Hold the airbrush 6-8 inches from the surface. Speed of movement controls density of color and fading effects at beginning and end of strokes.
3. For detail, hold the airbrush very close to the surface and pull back very slowly on the Trigger to release a small amount of airbrush color.
4. For shading and broader patterns, hold the airbrush away from the work surface and pull back further on trigger to release a larger required amount of color.

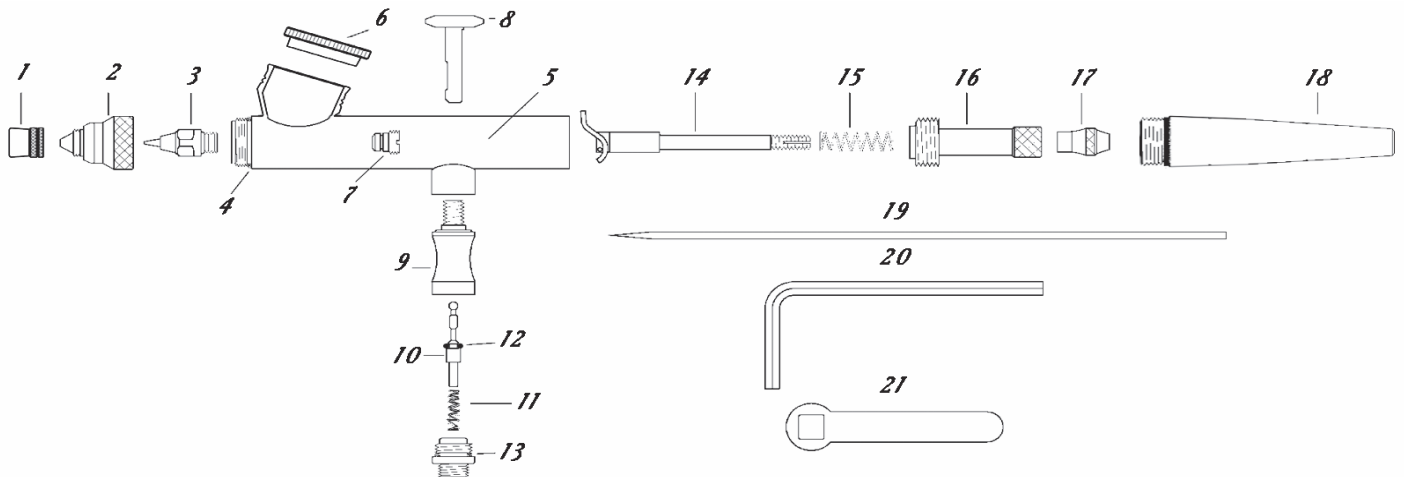

<u>NO.</u>	<u>PART</u>	<u>DESCRIPTION</u>
1.	XI-41	Needle Protection Cap
2.	TA-2	Aircap
3.	TT-2	Fluid Tip
4.	AE-69	"O" Ring
5.	JM-30	Shell
6.	RG-8	Cup Cover
7.	TAL-10	Packing Assembly PTFE
8.	TAL-37	Trigger
9.	TAL-14	Valve casing
10.	TAL-36	Valve Plunger
11.	A-22	Air Valve Spring
12.	TAL-26	"O" Ring
13.	TAL-15	Valve Adapter
14.	TAL-18	Rocker Assembly
15.	MIL-11	Needle Spring
16.	TAL-17	Spring Housing
17.	TAL-19	Needle Locknut
18.	JM-6	Handle
19.	TN-2	Needle
20.	TAL-35	Allen Wrench
21.	TAL-28	Wrench

REMOVING / REPLACING THE NEEDLE AND HANDLE:

1. Unscrew the handle and loosen the Locknut- #TAL-19 by turning counterclockwise. Gently remove the needle, rotating if necessary, Do NOT force out!
2. Inspect the condition of the needle. If it is bent or misshapen in any way, replace it with a new needle. A bent needle can damage or split the Tip- #TT-2 causing bubbles or a rough spray pattern.
3. Insert the new needle into the Rocker Assembly- #TAL-18. Gently push needle through, rotating if necessary, push gently forward until the needle stops in the front of the tip.
4. Tighten locknut by turning clockwise.

REPLACING THE FINGER LEVER ASSEMBLY:

If the Trigger- #TAL-37 is removed, it is easiest to replace before the Rocker Assembly- #TAL-18 is inserted. The needle must be removed.

1. Hold trigger so the round side of the stem is to the front and flat side to the back of the airbrush.
2. Insert trigger straight DOWN through the opening in the top of the airbrush shell.
3. You want the bottom of the trigger to cover the round ball on top of the exposed plunger. Proceed to replace Rocker Assembly- #TAL-18 and balance of parts as above. When the needle is inserted it will prevent the removal of the trigger.

REPLACING THE TIP:

1. Remove handle, loosen Locknut- and withdraw needle about one inch (1").
2. Un-screw the Aircap- #TA-2 and remove. The Tip- #TT-2 can now be unscrewed with supplied wrench.
3. Place a new tip into position and tighten with wrench. The tip must be wrench tight. Finally push the needle forward until it is seated fully forward into tip.

ADJUSTING WORN PACKING WASHER:

1. If Packing Assembly- #TAL-10 becomes worn or loose it must be tightened or replaced.
2. Tighten packing nut with small screwdriver. To reach packing all internal parts must be removed.
3. Replace needle and make sure packing nut is not too tight. A slight resistance to movement is needed when needle is passed through.
4. Completely re-assemble guts of airbrush.

CLEANING THE AIRBRUSH:

1. Spray airbrush cleaner through airbrush until it has no more color spraying out of airbrush.
2. Remove needle and wipe clean then replace.
3. If makeup has dried for a time you can remove the front tip, and aircap for soaking or soak just the front of the airbrush in cleaner.
4. Any paint cleaner is fine. Keep trigger area dry if soaking.

PERSONAL SETTINGS:

Spring Housing- #TAL-17 Used to increase or decrease spring tension for the trigger pull back. Thread into the shell until the trigger stroke feels comfortable. Threading in until it stops can cause the trigger to jam.

TROUBLESHOOTING:

Bubbling in cup:

1. Aircap- #TA-2 needs to be tightened
2. Tip- TT-2 needs to be tightened further

Skipping or Spitting:

1. Paint too thick -reduce with thinner
2. Tip not seated -tighten Tip- #TT-2 with wrench
3. Tip split or damaged needle -replace tip or needle
4. Needle or tip dirty -clean and replace
5. Air pressure too low -increase pressure

Airbrush Not Spraying:

1. Clogged Tip- #TT-2 -remove tip and clean
2. Needle not moving -tighten needle locknut
3. Low air pressure -increase pressure

Sprays double line or heavy to one side:

1. Split Tip- #TT-2 or bent Needle- #TN-2 - replace
2. Dirty tip or needle - remove and clean

Jammed trigger or poor trigger motion:

1. Adjust Spring Housing- #TAL-17 - screw or unscrew the spring housing to lessen or increase tension on trigger motion
2. Paint leaking to trigger area - remove guts of airbrush and slightly tighten packing or replace if needed