



SLACKER

DIGITAL SUSPENSION TUNER

USER GUIDE



GET IT ONLINE

U.S. PATENT NO. 9,021,872

WHAT'S IN THE BOX

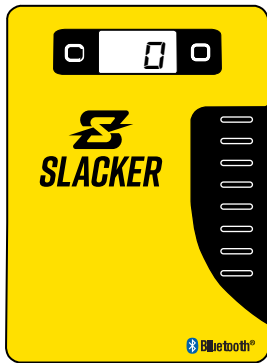

SLACKER DIGITAL SUSPENSION TUNER

See page 3 for detailed overview.

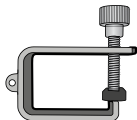

UNIVERSAL CLIP

Used on dirt bike plastics, etc.



UNIVERSAL SLACKER MOUNT

Strap on forks, shock, or frame.



2X 7MM SEAT RAIL LOOPS

Used on bicycle seat rails.

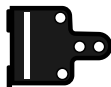

UNIVERSAL FORK ADAPTER

Strap to forks, or large shock bodies.



IOX CLEAR ADHESIVE LOOPS

Used for street bike bodywork, etc.



2X CINCH STRAPS

Used to attach the Universal Fork Adapter and Universal Slacker Mount.

TABLE OF CONTENTS

WHAT'S IN THE BOX?	PAGE 1
TABLE OF CONTENTS	PAGE 2
SLACKER FUNCTIONAL OVERVIEW	PAGE 3
INITIAL SETUP FOR REMOTE	PAGE 5
USING ON FORKS AND LARGE SHOCK BODIES	PAGE 6
MOUNTING ON DIRT BIKES	PAGE 7
MOUNTING ON STREET AND ADVENTURE BIKES	PAGE 9
MOUNTING AND INITIAL SETUP FOR MTB/E-BIKES	PAGE 11
TAKING MEASUREMENTS- MOTORCYCLES	PAGE 13
TAKING MEASUREMENTS- MTB/E-BIKES	PAGE 14

SLACKER V5 FUNCTIONAL OVERVIEW



OVERVIEW

1 POWER/RESET

- Press for 1 second to power on.
- Press for 5 seconds to power off.
- Press once to reset to "0".
- Automatically turns off after 5 min.

2 WIRELESS REMOTE PAIRING*

- With both units off, press and hold the Power and Backlight buttons on the main unit until it displays "PA", then release them.
- Press and hold the Power and Backlight buttons on the wireless remote until it displays "PA", then release them.
- Both units will sync and show "0".

3 LCD DISPLAY

- Displays readings in millimeters or %.
- Backlight for poor lighting conditions.
- Measures up to 920 mm from any point in the cables' travel.

*You do not need to pair your phone, just the wireless remote.

4 BACKLIGHT/AUTO ZERO/ % MODE

- Press for 1 second to turn backlight on.
 - Hold for 5 seconds to enter Auto Zero Mode.
 - Press twice to switch between mm and % modes*.
- *See Page 14 for details.

5 UNIVERSAL CLIP STORAGE CHANNEL

- Secures universal clip to the back.

6 UNIVERSAL CLIP

- Clips to fenders and number plates.
- Secures to rear for easy storage.

7 RETRACTABLE CABLE

- 36" retractable "Slacker" cable.

8 UNIVERSAL MAGNETIC MOUNT

- Sticks to steel axles up to 1" in diameter.

9 BATTERY COMPARTMENT

- Requires (2) AAA batteries, not included.

INITIAL SETUP FOR REMOTE DISPLAY

SERVICE ASSISTANT + VIRTUAL REMOTE APP



- Save unlimited bikes and settings.
- Save unlimited setup notes.
- Save measurements in real-time.
- No pairing required.

SLACKER VIRTUAL REMOTE APP



- Free basic virtual remote app.
- See readings and control basic functions.
- No pairing required.

OPTIONAL WIRELESS REMOTE INITIAL SETUP



PRESS AND HOLD

- With both units off, press and hold the Power and Backlight buttons on the main unit until it displays "PA", then release them.
- Press and hold the Power and Backlight buttons on the wireless remote until it displays "PA", then release them.
- Both units will sync and show "0".

MOUNTING ON FORKS OR LARGE SHOCK BODIES

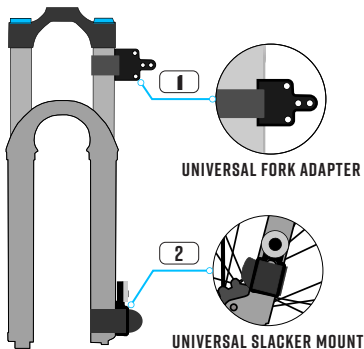

-Slacker cable exits the case at a 90° angle.

1 MOUNT THE UNIVERSAL FORK ADAPTER

-Strap the universal fork adapter firmly to the upper fork tube or shock body.

2 PLACE SLACKER ON AXLE OR UNIVERSAL MOUNT

MOUNTING ON MOTORCYCLES

- 1) Stick Slacker on the axle using the magnet on the back.
- 2) Hook the retractable cable to the fork adapter.
- 3) Make sure the cable exits at a 90° angle.
- 4) Turn Slacker on*.

MOUNTING ON MTB FORKS AND UTV SHOCKS

- 1) Strap the Universal Slacker Mount firmly on the lower fork tube or shock body and stick Slacker to it.
- 2) Hook the retractable cable to the fork adapter.
- 3) Make sure the cable exits at a 90° angle.
- 4) Turn Slacker on*.

*See how to take measurements on pages 13 and 14.

DIRT BIKES

MOST OFF-ROAD BIKES

HONDA, YAMAHA, KAWASAKI, SUZUKI, BETA, SHERCO

MEASURE ACROSS THE ARC OF THE AXLE

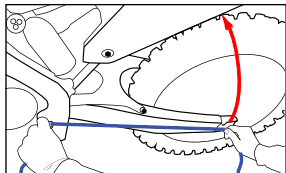
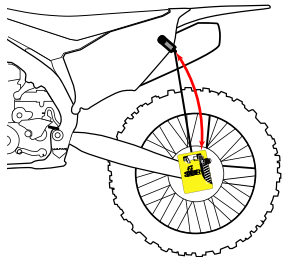

FINDING THE ARC OF THE AXLE



SCAN FOR VIDEO

AUSTRIAN BIKES

KTM, HUSQVARNA, GASGAS

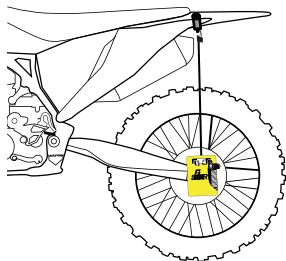

Butt of clip all the way against plastics.

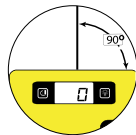

Slacker cable exits the case at a 90°

1 LOCATE CABLE ATTACHMENT POINT

-For KTM, Husqvarna and GasGas, place the clip at the factory provided sag marking on the rear fender. This should be pretty much directly vertical above the axle*.

-For most other dirt bikes you need to measure across the arc of the axle. Just stretch a charging cable, or piece of string from the swingarm pivot axle, to the rear axle. Now swing the end at the rear axle up until it hits the plastics. This is where you will place the clip*.

2 PLACE SLACKER ON THE AXLE

-Stick Slacker to the axle with the magnet centered to make sure it gets a good bite.

3 HOOK UP THE RETRACTABLE CABLE

-Extend the retractable cable and hook it on the universal clip, or optional hole.

4 POWER SLACKER ON

-Press and hold the power button for 1 second to power Slacker on. Also power up the wireless remote or open the virtual remote display app on your smartphone.

5 TAKE YOUR MEASUREMENTS

-See page 13 for detailed directions on taking measurements.

*You can also drill a tiny hole in the plastics for quicker setup.

STREET AND ADVENTURE BIKES

STREET BIKES

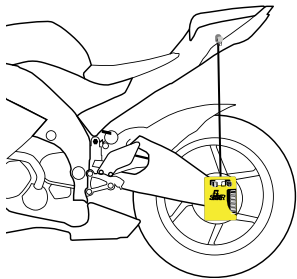

SCAN FOR VIDEO

ADVENTURE BIKES

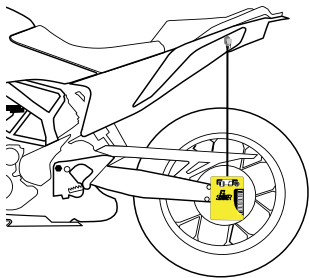

CLEAN THE SURFACE WELL BEFORE YOU PLACE THE ADHESIVE LOOP.



Place adhesive loop on body directly above the axle. Place the loop as vertically as possible for best grip.

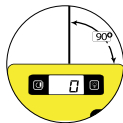

Place Slacker on the axle and extend the cable to the adhesive loop. Make sure the cable exits at a 90° angle.

1 PLACE ADHESIVE LOOP ON BODY

- Clean the bodywork directly above the axle where you plan to place the clear adhesive loop.
- Place a clear adhesive loop on the body and press firmly for 3-5 seconds to assure it has a good grip. If you can place it vertically, this will assure the best grip.

2 PLACE SLACKER ON THE AXLE

- Stick Slacker to the axle with the magnet centered to make sure it gets a good bite.

3 HOOK UP THE RETRACTABLE CABLE

- Extend the retractable cable and hook it on the clear adhesive loop you placed in step 1.

4 POWER SLACKER ON

- Press and hold the power button for 1 second to power Slacker on. Also power up the wireless remote or open the virtual remote display app on your smartphone.

5 TAKE YOUR MEASUREMENTS

- See page 13 for detailed directions on taking measurements.

MTB/E-BIKE INITIAL SETUP

SEAT RAIL LOOP



UNIVERSAL SLACKER MOUNT

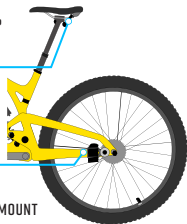

SCAN FOR VIDEO



AIR SHOCKS

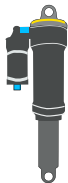

- 1 RECORD CURRENT PRESSURE**
Used to re-inflate the shock.
- 2 MOUNT SLACKER AND POWER IT ON.**
Make sure it reads "0" with shock extended.
- 3 DEFLATE THE SHOCK**
Be careful not to damage the valve.
- 4 BOTTOM OUT THE SHOCK**
Push the shock through the full travel.
- 5 RECORD RESULT IN APP**
Add the travel to your bike settings in the app.
- 6 RE-INFLATE THE SHOCK**
See P 14 for taking measurements.

COIL SHOCKS

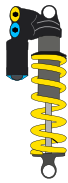

- 1 REMOVE SHOCK SPRING**
Re-mount shock body without the spring.
- 2 MOUNT SLACKER AND POWER IT ON.**
Make sure it reads "0" with shock extended.
- 3 BOTTOM OUT THE SHOCK**
Push the shock through the full travel.
- 4 RECORD RESULT IN APP**
Add the travel to your bike settings in the app.
- 5 RE-MOUNT SPRING ON SHOCK BODY**
See P 14 for taking measurements.

- 1 STRAP UNIVERSAL MOUNT TIGHTLY ON THE FRAME**
-Strap the universal mount tightly to the rear of the frame, close to the axle.
- 2 CLIP SEAT RAIL LOOP TO THE SEAT RAIL**
-Clip on the rail on the same side as you are placing Slacker for best cable alignment.
- 3 STICK SLACKER TO THE UNIVERSAL MOUNT**
-Stick Slacker to the universal Slacker mount.
- 4 HOOK THE RETRACTABLE CABLE ON THE LOOP**
-Extend the retractable cable and hook it on the clear adhesive loop you placed in step 1.
- 5 POWER SLACKER ON**
-Press and hold the power button for 1 second to power Slacker on. Also power up the wireless remote or open the virtual remote display app on your smartphone.
- 6 TAKE YOUR MEASUREMENTS**
-See page 14 for detailed directions on taking measurements.

1 PLACE SLACKER IN AUTO ZERO MODE

- Remove the bike from the stand so the weight is placed on the suspension.
- Place Slacker in Auto Zero mode by holding the backlight button for 5 seconds, or you can trigger it from the virtual remote app. A cursor will begin to scroll up the LCD indicating you need to lift the bike.

2 LIFT THE BIKE TO UNLOAD THE SUSPENSION

- Lift the bike in one smooth motion until the suspension tops out. If you stop, or let the cable retract at all, you will not get the correct zero reference point.
- Slacker will automatically mark the point where the suspension is fully unloaded and will now present all of the measurements in real-time.

3 MOUNT THE BIKE IN FULL RIDING GEAR

- With the bike on flat ground, with fluids topped off, mount the bike in full riding gear.
- Balance the bike using a wheel chalk, or you can use your elbow to balance against a fence, van, etc.

4 TAKE YOUR MEASUREMENT

- Pump the suspension a couple of times to settle it.
- Sit in a normal riding position where you would normally sit when entering a turn.
- Save the measurement to your notes from the virtual remote app so you can remember your settings.

SLACKER DISPLAY MODE

Slacker can show you either the measurement in millimeters, or the percentage of travel you are using. Just add your travel to the app and it will automatically sync to Slacker when it connects. Then you can toggle between modes using the app, or by pressing the backlight button twice. Travel is reset when Slacker is powered off to avoid having the wrong value stored. Slacker will always start in MM Mode.

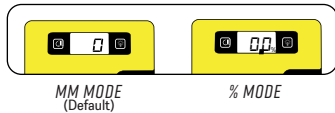

1 MAKE SURE SLACKER READS “0” WITH SUSPENSION FULLY UNLOADED

-Make sure Slacker reads “0” with the suspension fully unloaded. If not, just press the power button once, or use the app to reset it to “0”.

2 MOUNT THE BIKE IN FULL RIDING GEAR

-With the bike on flat ground, mount it in full riding gear including any hydration packs, etc.
-Use your elbow to blance against a fence, tree, etc.

3 TAKE YOUR MEASUREMENT

-Pump the suspension a couple of times to settle it before you read your measurement.
-Save the measurement using the virtual remote app for future reference.
-Be sure to remove the seat rail clip, and universal Slacker mount before you hit the trails.

LEGAL DISCLAIMER

Slacker LLC is not responsible for any damage or injuries caused by improper bike setup. Any settings are provided as a guideline only. It is the end-user's responsibility to determine the correct adjustments based on the manufacturer's recommendations, and to perform the work in a safe and professional manner. All adjustments and work performed are the end-user's responsibility.

FCC REGULATORY INFORMATION

NOTE: This equipment has been tested and found to comply with the limits for a Class B digital device, pursuant to part 15 of the FCC Rules. These limits are designed to provide reasonable protection against harmful interference in a residential installation. This equipment generates, uses and can radiate radio frequency energy and, if not installed and used in accordance with the instructions, may cause harmful interference to radio communications. However, there is no guarantee that interference will not occur in a particular installation. If this equipment does cause harmful interference to radio or television reception, which can be determined by turning the equipment off and on, the user is encouraged to try to correct the interference by one or more of the following measures:

- Reorient or relocate the receiving antenna.
- Increase the separation between the equipment and receiver.
- Connect the equipment into an outlet on a circuit different from that to which the receiver is connected.
- Consult the dealer or an experienced radio/TV technician for help.



© 2024 Slacker LLC. All rights reserved. Slacker, and the Slacker logo are trademarks of Slacker LLC., registered in the U.S., China and other countries.

