

Technical data model VSIII

Model	EAN-No. 4025092*	Capacity in kg/ number of chain falls	Chain dimensions d x p mm	Lift per 1 m hand chain overhaul mm	Pull on hand chain at WLL daN	Weight at standard lift (3 m) kg
VSIII 0,25/1	*665322	250/1	4x12	50	20	3.9
VSIII 0,5/1	*949545	500/1	5x15	26	21	9.0
VSIII 1,0/1	*949927	1000/1	6x18	24	24	11.5
VSIII 1,5/1	*593854	1500/1	8x24	17	30	17.5
VSIII 2,0/1	*949934	2000/1	8x24	19	32	19.0
VSIII 2,0/2	*949941	2000/2	6x18	15	29	17.3
VSIII 3,0/1	*949958	3000/1	10x30	12	40	31.0
VSIII 3,0/2	*949965	3000/2	8x24	10	37	27.0
VSIII 5,0/2	*949972	5000/2	10x30	8	41	43.0

Dimensions model VSIII

Model	VSIII 0,25/1	VSIII 0,5/1	VSIII 1,0/1	VSIII 1,5/1	VSIII 2,0/1	VSIII 2,0/2	VSIII 3,0/1	VSIII 3,0/2	VSIII 5,0/2
A min., mm	290	350	380	450	460	490	570	580	700
B, mm	12	21	28	33	36	36	45	45	47
C, mm	26	23	27	36	35	35	40	40	45
D, mm	11	16	20	22	29	29	29	29	40
E, mm	118	145	158	180	205	170	240	220	250
F, mm	113	140	155	175	180	155	210	175	190
G, mm	65	80	87	85	94	87	110	94	95
H, mm	48	60	68	90	86	68	100	81	95
K, mm	190	240	270	300	320	285	370	340	410

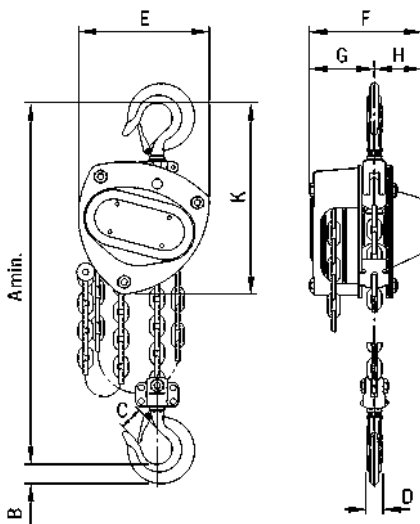

Model VSIII, 250 - 3000 kg, single fall

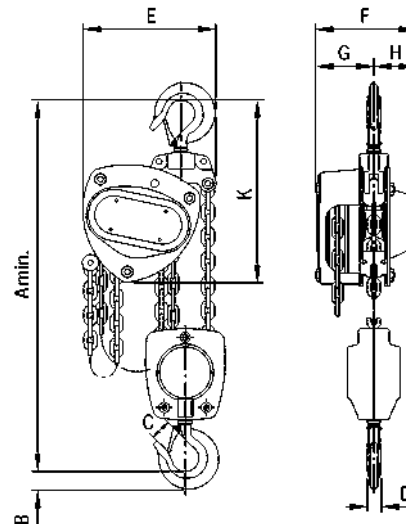

Model VSIII, 2000 - 5000 kg, double fall



Option: Chain container