

Hand pallet truck with quick-lift model HU 20-115 QLTP PROLINE

Capacity 2000kg

For quick lifting and professional transportation of palletised goods and box pallets under demanding conditions.

Features

- Ergonomic safety control handle for one-hand operation of lifting, driving and lowering.
- Ergonomic rubber control handle for safe handling.
- Low maintenance high performance hydraulic pump with hard chromium plated piston and pressure relief valve.
- Quick-lift function for loads up to 200kg for quick lifting of the load.
- Frame and forks in robust steel construction, adjustable connecting rods, especially hardened axles and the high quality powder coating ensure a long life expectancy.
- Steering angle of 105 degree to each side for easy handling in confined spaces.

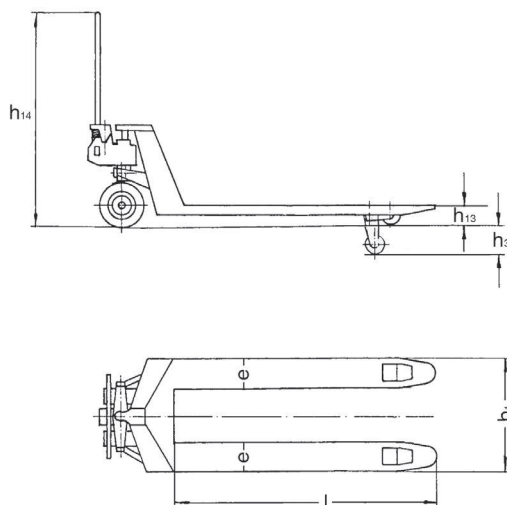

Technical data model HU 20-115 QLTP

Model	HU 20-115 QLTP
Art.-No.	034527125
Capacity, kg	2000
Weight, kg	86
Tyre type ¹	VG/PUR
Steering rollers, mm	200x50
Load rollers, mm	82x70
Stroke h3, mm	115
Height of control handle h14, mm	1200
Fork height lowered h13, mm	85
Fork width e, mm	160
Fork length l, mm	1150
Outside dimension of forks b1, mm	540

¹PUR... Polyurethane, VG... Solid rubber