

SPRINT TL

- a one of a kind order picker for tires
- it reaches a 5.35 mt working height
- able to complete a full rotation on its axis
- control panel equipped with a large LCD display showing vehicle status, system operating time and battery status via a charge indicator
- High-Cycle batteries allowing for a great number of raise/lower cycles
- platform capacity of 130 kg and ultra-compact size (1500x808x1600 mm) allow for an exceptional maneuverability
- innovative Lift Compartment System can load up to 100 kg
- innovative lifting mast system, guaranteed 10 years



Why choose Sprint TL?

EFFICIENT AND VERSATILE

SPRINT TL lifts the operator and tires, easily positioning them at the desired height and allowing for a faster and safer performance than if manually handled. The innovative Lift Compartment System can be loaded with up to four tires, depending on size and weight. The set of roller side guides are electrically operated to roll-in tires allowing the operator to easily pick up tires from the Lift Compartment.

SAFE

SPRINT TL has a drive speed of 5 Km/h while stowed and of 1.2 Km/h when lifted. The hand sensors and dual foot switches on the platform ensure the correct position of the operator while actively onboard or using the lifting functions. The heavy duty steel case construction and frame allow to the operator to safely handling tires up to 100 kg, avoiding the risk of injuries related to manual movement.

DURABLE

Simple, efficient, and comfortable the SPRINT TL is the result of continuous technical improvements. The innovative lifting mast requires no upkeep, while the careful selection of high-quality components, and an extremely simple yet effective design make the SPRINT TL virtually maintenance-free, designed to guarantee low ownership costs.

OPTIONAL: It is possible to fully eliminate batteries' maintenance by installing AGM batteries, available also for all our products.

"The Sprint TL is an innovative piece of equipment meant to save your back and increase operator productivity, efficiency and safety."



Measurements

A	Working Height	5350 mm	Platform capacity	130 kg
B	Platform Height	3350 mm	Weight (CE)	794 kg
C	Min. height of tire holder from the ground	722 mm	Rated n° of occupants (CE)	1
D	Unit height – with stowed tires holder	1600 mm	Platform width	809 mm
E	Unit height – with elevated tires holder	1995 mm	Drive Speed Stowed	5 km/h
F	Tot. unit width	808 mm	Drive Speed Elevated	1.2 km/h
G	Tot. unit length	2243 mm	Gradeability while elevated	T.L. 2° TLP 1.5°
H	Platform length	1500 mm	Inside turning radius	ZERO
I	Lift compartment system max. capacity	100 kg	Power Source	110/220 V ca 24Vcc
L	Entry Step	360 mm	Batteries	n° 4 - 6V; 245Ah@20h
M	Lift compartment system width	410 mm		

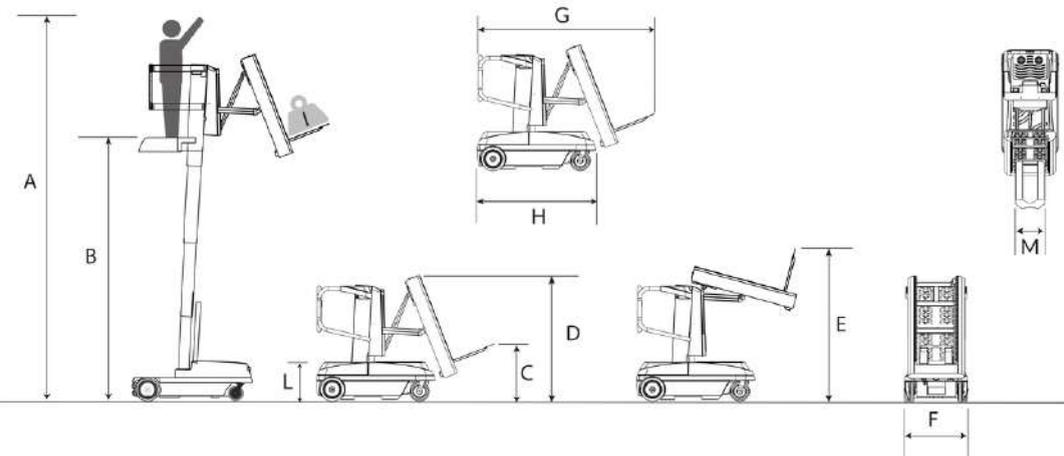

Contacts

info@bravi-platforms.com

www.bravi-platforms.com

+39 071 7819090



BRAVI
PLATFORMS