



**TUCKER**  
BARBECUES

**ASSEMBLY, INSTALLATION  
AND OPERATING INSTRUCTIONS  
FOR S WOK AND ST WOK**



**IMPORTANT – PLEASE READ ALL INSTRUCTIONS  
BEFORE YOU ASSEMBLE, INSTALL OR  
OPERATE THIS APPLIANCE.**

V11.12.19

GENERAL WARNINGS ..... 3

WOK ASSEMBLY INSTRUCTIONS..... 4

INSTALLATION INSTRUCTIONS & WARNINGS ..... 6

SPECIFICATIONS ..... 8

DIMENSIONS ..... 9

GAS INSTALLATION AND LEAK TEST PROCEDURE ..... 10

WOK OPERATING INSTRUCTIONS ..... 13

TROUBLESHOOTING ..... 14

SERVICE & MAINTENANCE ..... 15

WARRANTY..... 16

- Tucker S Wok and ST Wok are approved for outdoor use only.
- Remove all plastic protection film from stainless steel components before assembly.
- Keep this manual for future reference.
- Clean your Wok regularly; check the grease trays for excess grease build up as damage by grease or fat fire is not covered by warranty.
- Always turn off the gas supply when you finish cooking.
- A canvas cover for this Wok will extend its life and ensure trouble free operation.
- Attend an operating Wok at all times.
- **Do not** use this appliance indoors or in any enclosed area.
- **Do not** spray aerosols in the vicinity of this appliance while it is in operation.
- **Do not** place articles on or against this appliance.
- Read all instructions carefully before assembly and usage of the Wok.
- **Do not** use or store flammable materials in or near this appliance.
- Always leak test /check hose connections after filling cylinders.
- Check cylinder condition for rust and that the date stamp is current as every gas cylinder in Australia must be pressure tested every ten years.
- Never disconnect the Wok whilst it is running.
- **Do not** modify this appliance in any way.
- **Do not** allow children to operate the Wok.
- If a grease/fat fire should arise, turn off the gas supply immediately until extinguished.
- Always open the Lid before lighting the Wok.

## **HAZARDOUS FIRE OR EXPLOSION MAY RESULT IF INSTRUCTIONS ARE IGNORED.**

It is the consumer's responsibility to see that the barbecue is properly assembled, installed and taken care of. Failure to follow the instructions in this manual could result in serious bodily injury and /or property damage.



### **WARNING FOR YOUR SAFETY**

If you smell gas:

1. Shut off gas supply to appliance.
2. Extinguish any open flame.
3. Open lid or hood.
4. If odour continues, immediately call your gas supplier or your Fire Department.



## TOOLS REQUIRED FOR ASSEMBLY



10mm spanner



Phillips head screwdriver

- Remove any plastic protection film covering the Wok and components before assembly.
- Cut away any packaging or cable ties that may be holding components in place.
- Check you have all the correct components as listed below.

## WOK PARTS



**4x** Bolts

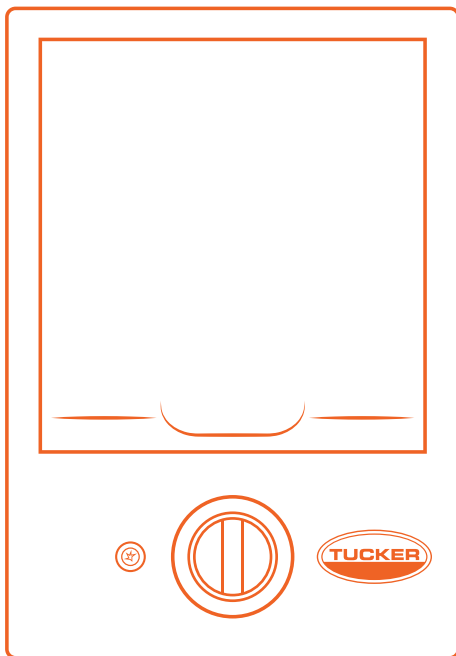

**1x** Wok Body



**Right Side**



**Left Side**

**2x** Grease Tray Brackets

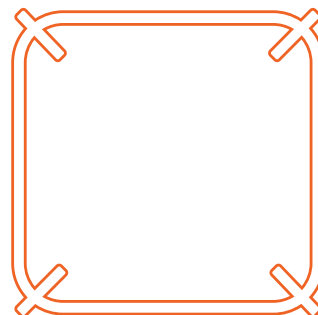

**1x** Wok Trivet

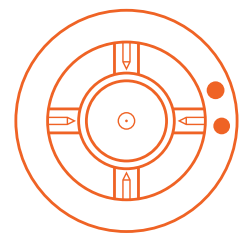

**1x** Wok Burner

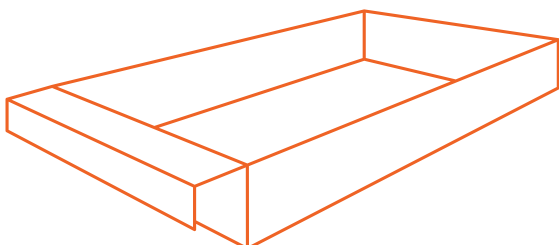

**1x** Grease Drip Tray

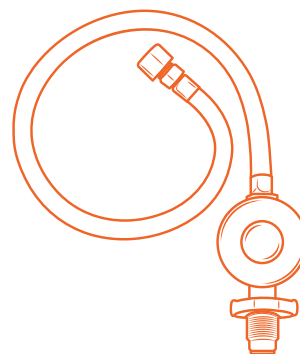

**1x**  
Hose and Regulator



**2x**  
Black Enamel  
Burner Tops



**NOTE:**

- A mobile trolley is optional. If you have one, read the trolley shelf assembly instructions and fit the Wok onto the trolley before final barbecue assembly.
- Check that you have the correct gas type Wok.
- Propane Gas, (orange sticker)
- Natural Gas, (black sticker)
- The gas label is located next to the gas inlet on the base of the Wok.

**WOK ASSEMBLY**

1. Bolt the 2x drip tray brackets onto the base of the Wok using the nuts and bolts provided.

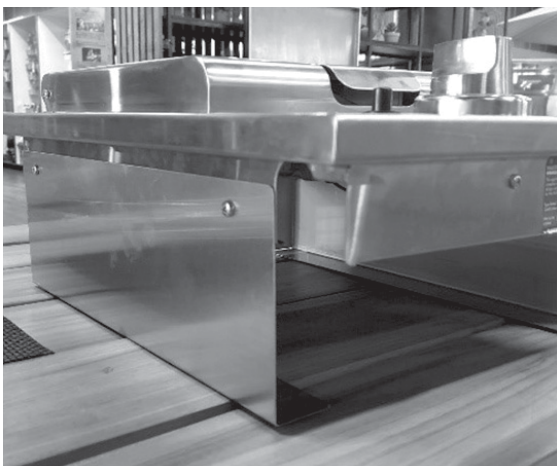

2. Now slide the grease tray into position at the base of the Wok between the grease tray support brackets.

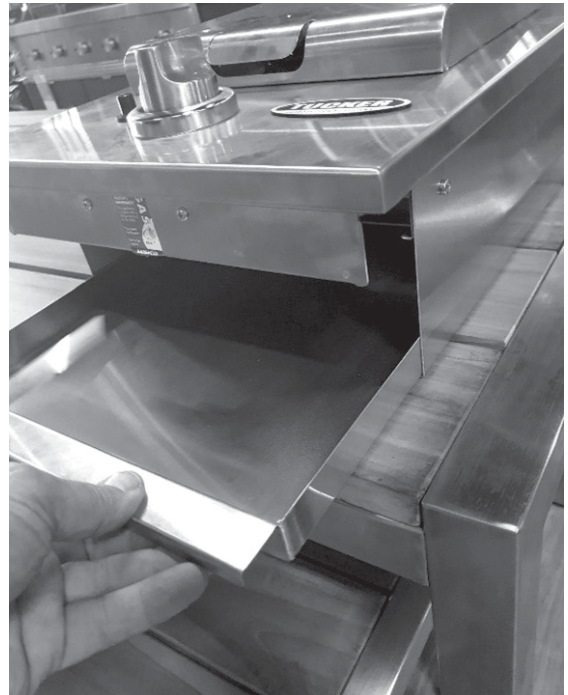

3. Now make sure the 2 x enamel burner ring tops are in place over the burners and the wok is assembled.



**NOTE:**

Once you have assembled the Wok wipe it over to remove greasy fingerprints with stainless steel polish and a soft cloth.

## WOK INSTALLATION INSTRUCTIONS

---

### READ THE IMPORTANT INFORMATION ON THE LID OF THE WOK.

This Wok is designed and approved for outdoor use only.

Be mindful of the location of installation of the Wok, strong winds blowing across the Wok whilst cooking can cause the Wok to blow out.

## INSTALLATION WARNINGS

---

**Do not** use this appliance indoors or on marine craft.

This appliance shall only be used in an above ground, open-air situation with natural ventilation, without stagnant areas where gas leakage and products of combustion are rapidly dispersed by wind and natural convection.

Any enclosure in which the appliance is used shall comply with one of the following:

- An enclosure with walls on all sides, but at least one permanent opening at ground level and no overhead cover. (*figure 1*)
- Within a partial enclosure that includes an overhead enclosure and no more than two walls. (*figure 2 and 3*)
- Within a partial enclosure that includes an overhead cover and more than two walls, the following shall apply. (*figures 4 and 5*)
- At least 25% of the total wall area is completely open.
- At least 30% of the remaining wall area is open and unrestricted.
- In the case of balconies, at least 20% of the total of the side, back and front wall areas shall be and remain open and unrestricted.

## DIAGRAMMATICAL REPRESENTATIONS OF OUTDOOR AREAS

The following figures are diagrammatical representations of outdoor areas. The areas used in the figures below are examples – the same principles apply to any other shaped area.

**FIGURE F1 – OUTDOOR AREA – EXAMPLE 1**

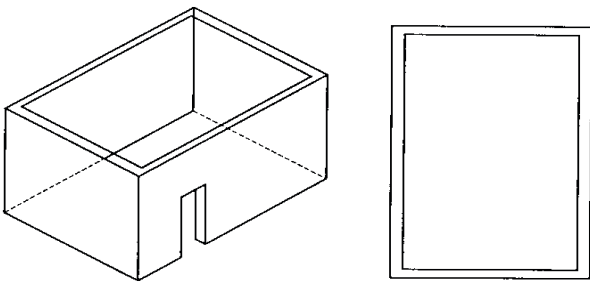

**FIGURE F2 – OUTDOOR AREA – EXAMPLE 2**

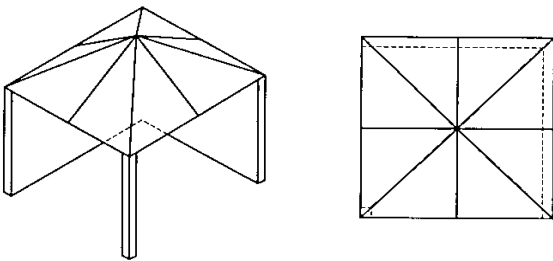

**FIGURE F3 – OUTDOOR AREA – EXAMPLE 3**

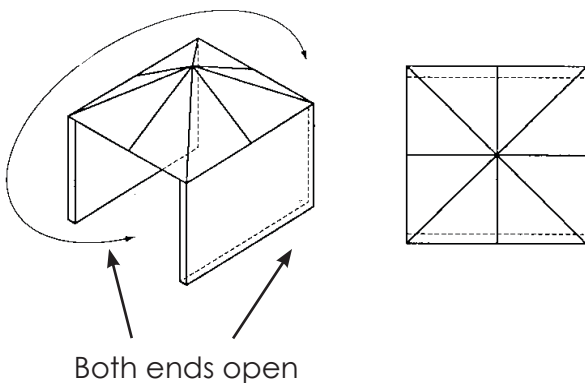

**FIGURE 4 OUTDOOR AREA –EXAMPLE 4**

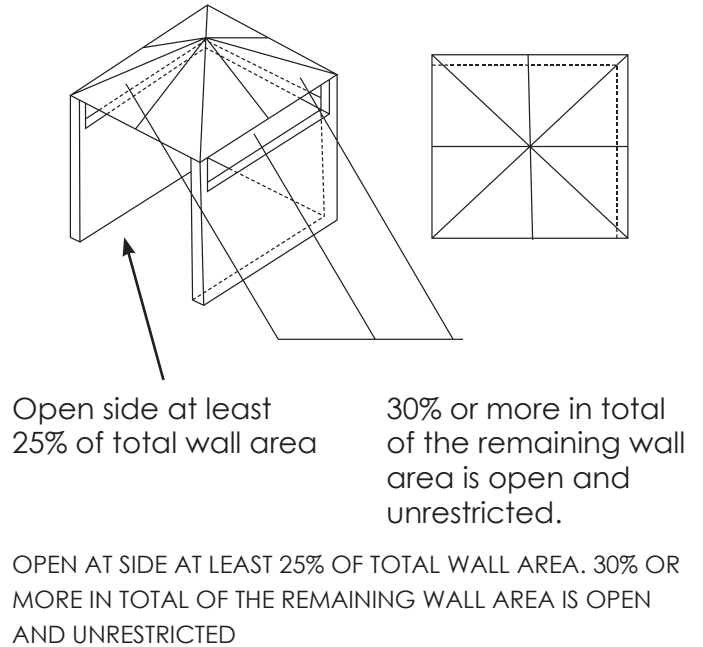

**FIGURE F5 – OUTDOOR AREA – EXAMPLE 5**

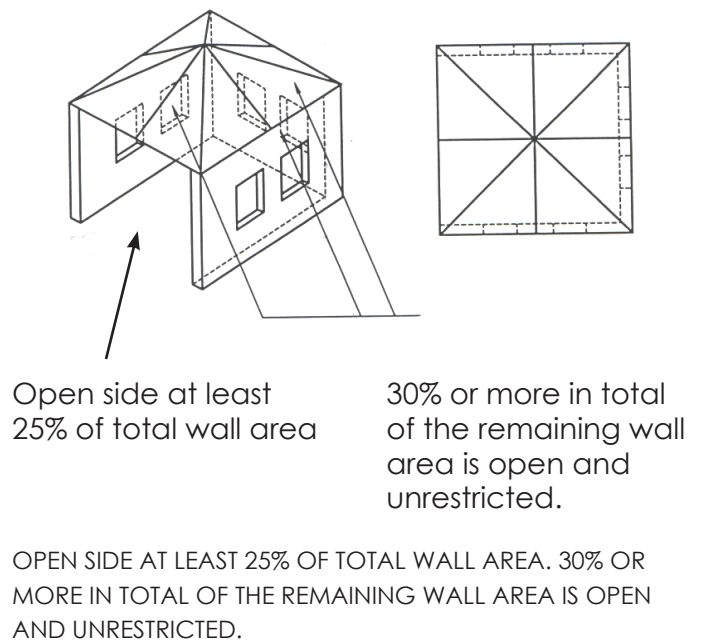

**S WOK GAS CONSUMPTION**

*(In Mega Joules Per Hour)*

Model	Natural Gas	LPG:
<b>S Wok</b>	12.5mj	15mj
Natural Gas injector size 1.8mm Pressure 1KPA		
Propane Gas injector size 1.1 mm Pressure 2.75 KPA		

Model	Natural Gas	LPG:
<b>ST Wok</b>	12.5mj	15mj
Natural Gas injector size 1.8mm Pressure 1KPA		
Propane Gas injector size 1.1 mm Pressure 2.75 KPA		

**TUCKER S WOKS ARE MADE AND APPROVED TO AUSTRALIAN STANDARDS A.G.A. APPROVAL NO. AGA 8236-G**

For LP Gas connections, an approved 2.75 KPA regulator and hose assembly connection to the appliance is fitted by the manufacturer. The appliance inlet is 3/8 S.A.E. male and is located at the base of the Wok at the front.

The minimum capacity propane cylinder for this Wok is 4 KG.

**WARNING:** Warning in freezing conditions the pressure of Propane gas can be reduced in the Cylinder Tank causing a lack of gas pressure, this may affect the way the barbecue operates.

The intended use of this Wok is to be installed onto a Tucker Cabinet trolley.

Alternatively, it may be set into brickwork.

Be sensible about the location of your Wok.

The Wok must be located on firm and level ground.

**Do not** locate the Wok near combustible materials or surfaces, either above or around the Wok.

**Do not** obstruct any of the air ventilation openings below the Wok burner.



**DIMENSIONS OF WOK**

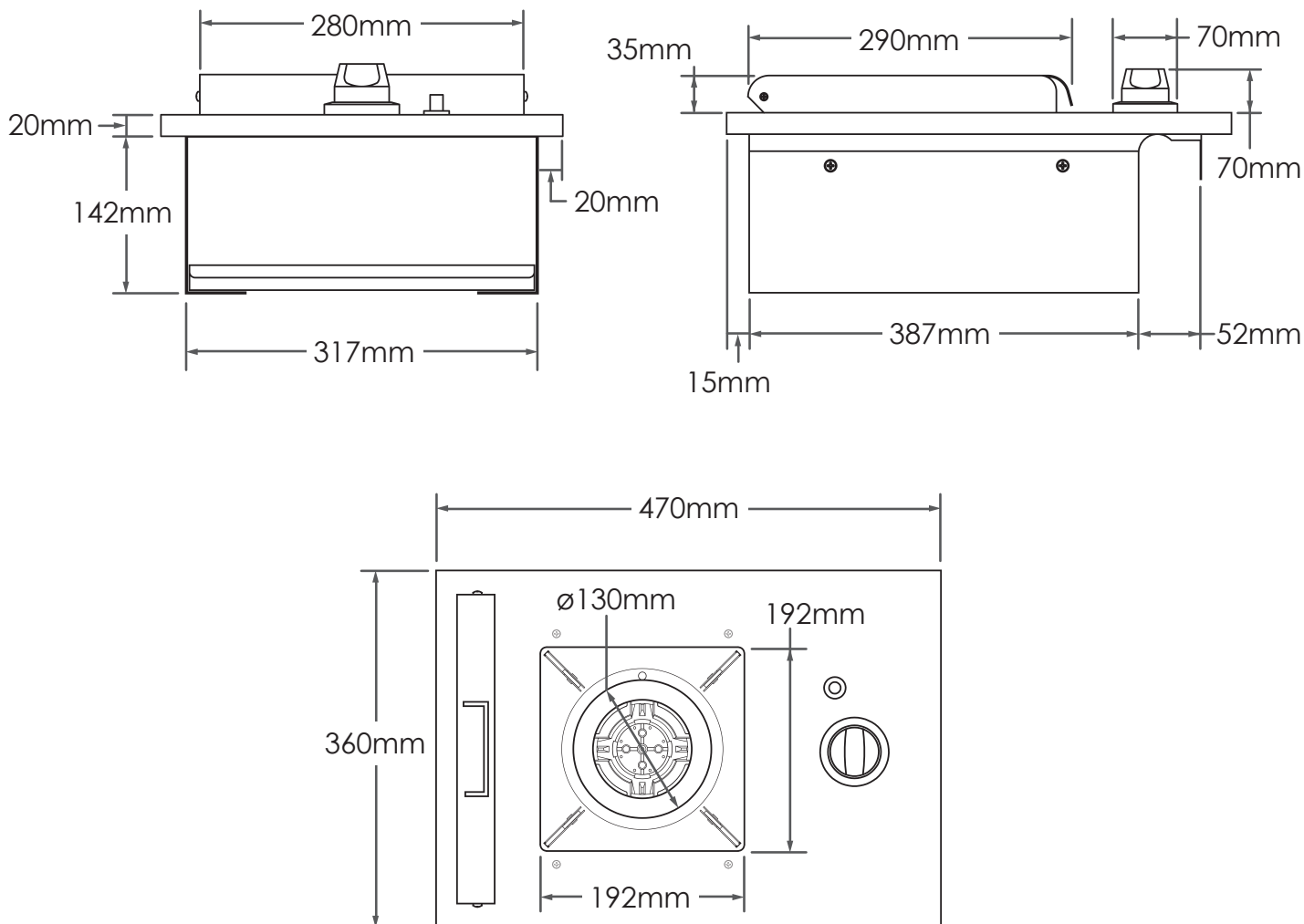

**S WOK CUT-OUT DIMENSIONS**

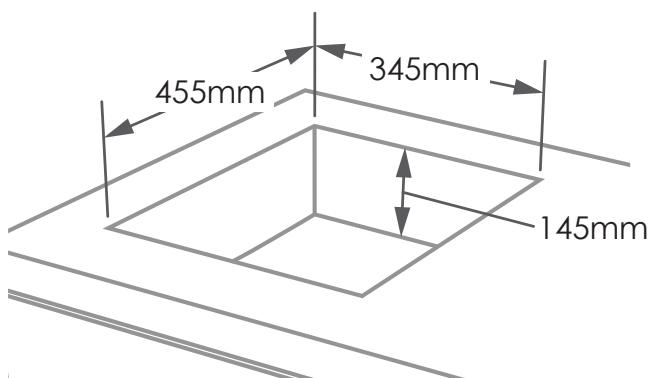

**CLEARANCES TO COMBUSTIBLE MATERIALS ARE AS FOLLOWS:**

- Minimum Side Clearance Allow 200mm**
- Minimum Rear Clearance Allow 200mm**
- Minimum Top Clearance Allow 800mm**

**NOTE:**

The wall surfaces above the Wok cooking surface at the rear and either side of the Wok must be non-combustible material or have a clearance of 100mm.

## CONNECTION OF A GAS CYLINDER TO THE WOK IS AS FOLLOWS

The hose assembly connection to the appliance is fitted by the manufacturer.

### WARNING:

There must be no naked flames in the area when connecting the Wok to a gas supply.

- Attach the regulator to the gas cylinder by tightening the wing nut on the regulator firmly by hand.

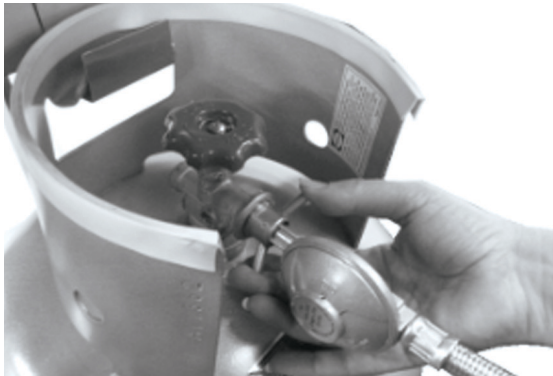

- Once connected, leak test the connections by brushing a solution of soapy water around the joints and gas cylinder valve.

### NOTE:

You must have the control knob in the off position and have the gas supply on at the cylinder valve to test for leaks.

**If bubbles appear around the connections, you have a leak.**



Photo of what a typical leak looks like.

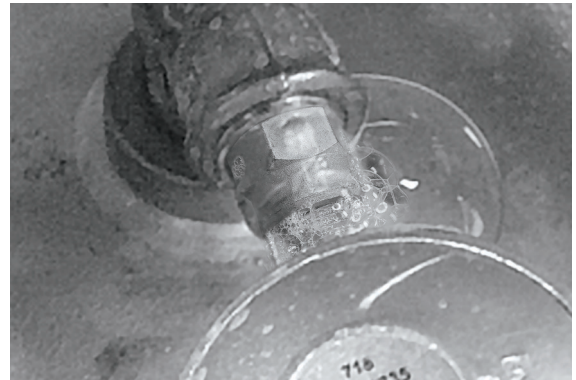

Photo of what a typical leak looks like.

**Turn off the gas supply and tighten or re-seal the connection.**

**Leak test the connections again**

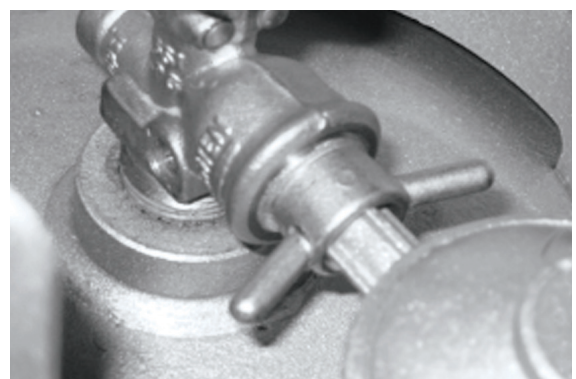
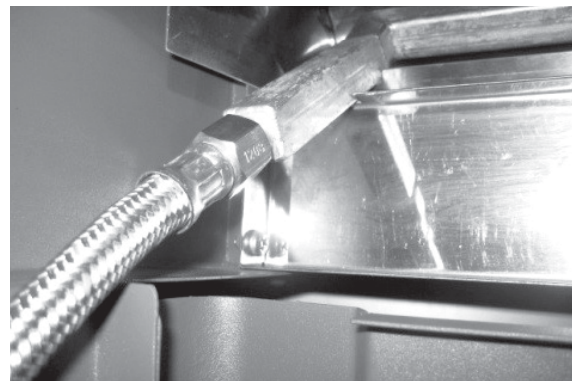

Photo of what a good connection looks like i.e. no bubbles.

If leaks are still present **do not** use the Wok, contact the place of purchase or your local dealer.

## **OPTIONAL ST WOK INSTALLATION TO A TUCKER BBQ CABINET TROLLEY.**

---

For the attachment of a ST Wok you will need to disconnect the existing hose connected to the inlet of the Barbecue and re-connect this hose to the inlet on the right-hand side of the Wok. Connect the shorter Wok hose to the outlet on the left-hand side of the Wok and connect the other end of the hose to the BBQ inlet.

The hose connections must be connected firmly with a spanner.

Check that the hose is not kinked or under tension.

Apart from the connection point the hose must not be touching any part of the barbecue or Wok where it may get hot and be damaged.

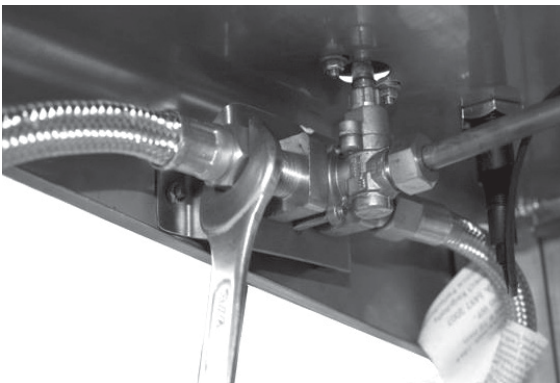

*Wok inlet connection.*

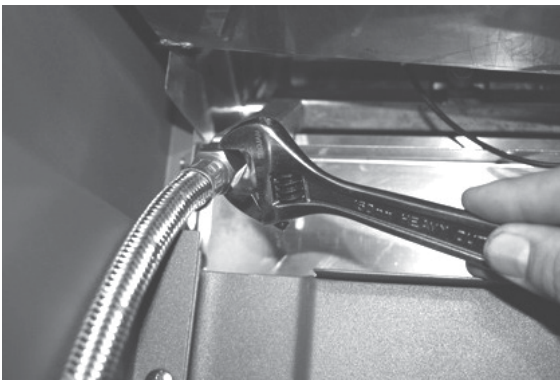

*BBQ inlet connection.*

## GAS INSTALLATION

### NOTE:

Check for leaks after each gas refill.

Check that the hose is not kinked or under tension. Apart from the connection point the hose must not be touching any part of the Wok burner where it may get hot and be damaged.

For storage, cylinder exchange or refilling, disconnect the hose at the cylinder only.

**Do not** disconnect the hose from the appliance.

**Do not** attempt to open or adjust the regulator, if you think it is not working properly consult your local dealer.

FOR PERMANENT CONNECTIONS to natural gas or a fixed propane supply, an authorised person, in accordance with these instructions, local gas fitting regulations, municipal building codes, the AGA installation code AS5601 and any other relevant statutory regulations, must be employed.

For connection to a natural gas bayonet fitting, a gas regulator must be fitted at the inlet of the appliance, and an approved 10mm, class A, natural gas hose (no longer than 2 metres), going from the gas regulator to the bayonet point, complying with AS1869 must be used.

Where a mobile appliance is to be connected to a fixed gas supply via a flexible hose connection the restraining cord supplied must be fixed to the appliance and the wall/floor within 50mm of each connection point. The length of the restraining cord shall not exceed 80% of the length of the hose as it is designed to prevent stress on the hose assembly when the appliance is moved out of its normal operating position.

It is recommended that an isolation valve and union be fitted before the Wok; refer AS5601/ AG601 for correct pipe sizing to ensure adequate gas is supplied to the appliance.

For natural gas check the pressure of the regulator and adjust it if necessary to the pressure shown on the data plate.

## PROPANE GAS TO NATURAL GAS CONVERSION PROCEDURE FOR AUTHORIZED INSTALLER

- Disconnect and remove the top part of the Wok burner and 2 black enamel rings from the Wok.
- Remove the injector and replace it with the correct 1.8mm Natural Gas injector.
- Re-assemble the burner.
- Replace the PROPANE gas hose and regulator with an approved natural gas regulator and hose.
- Turn the gas on and test for leaks, repair if necessary.
- Light the burner and set the pressure at 1 KPA.
- Turn the burner to the "LOW" setting and adjust it if necessary by removing the control knob. Insert the screw driver provided down the shaft of the control valve and turn it, you can adjust the "low" setting up or down to suit your gas pressure.

### NOTE:

Turn screw driver anti-clockwise to adjust the flame height up. Note you want to achieve the lowest flame height at "LOW" but you don't want to have it so low that it blows out on its own or due to a breeze.

- Check the operation of the ignition to the burner and make any necessary adjustment. Note Natural gas is lighter than air you may need to adjust the ignition probe up a little higher for it to light.

For alternative types of installation, contact your nearest dealer.

## WOK OPERATING

1. Open the lid before lighting the Wok.
2. Turn the gas control knob to the OFF position. (clockwise).
3. Turn on the gas supply at cylinder valve or supply.
4. Push and turn (Anti-clockwise) the control knob to high.
5. Wait for 3 seconds.
6. Push the ignition button next to the control knob 2 or 3 times to ignite the burner.



7. If the burner does not light turn the control knob to off, wait 1 minute and retry.

### WARNING:

If the Wok burner should not light after 10 seconds or go out due to strong winds, care should be taken.

Wait 1 minute before re-lighting to let any gas disperse.

### IMPORTANT:

**Do not** force the control knob, it will turn easily, depress the knob and turn it anti-clockwise. The gas control knob can be adjusted from high to low.

To turn the Wok off, simply turn the control knob to the OFF position, and then turn off the gas supply at the cylinder or supply.

## MANUAL LIGHTING INSTRUCTIONS

To light the Wok manually place a lit match next to the burner and turn the control knob to High.

### WARNING:

Cooking oil can ignite at 300-330 degrees Celsius if it comes in contact with the flame of the wok.

Be very careful if you pour oil into a very hot Wok also as oil can combust without a flame at 400-430 degrees Celsius.

## CLEAN UP

1. Check the grease collection tray after each use.
2. Wipe the Wok over with a soft cloth to remove grease and marks.
3. Close the lid to protect the Wok Burner from weather when the Wok is not in use.
4. Check the gas supply is turned off.
5. Cover the Wok and BBQ with a Tucker barbecue cover (optional extra).





## TROUBLESHOOTING SOLUTIONS

- Wok won't light? Check gas connections and that the gas bottle has gas.
- Ignition is not working? Check the ignition for a spark and adjust the spark gap to make sure the gap is 5-7mm from the ports on the burner. Note propane / L.P. Gas is heavier than air so your ignition probe should be positioned just lower than the ignition ports for the best position for ignition and Natural gas is lighter than air so it is best to adjust the igniton probe a little higher than the ignition ports on the burner for the best position for ignition.
- Check that the ignition lead is connected properly as the ignition lead might just need to be firmly connected into either the ignition probe or the ignition button correctly. The lead may be damaged also.

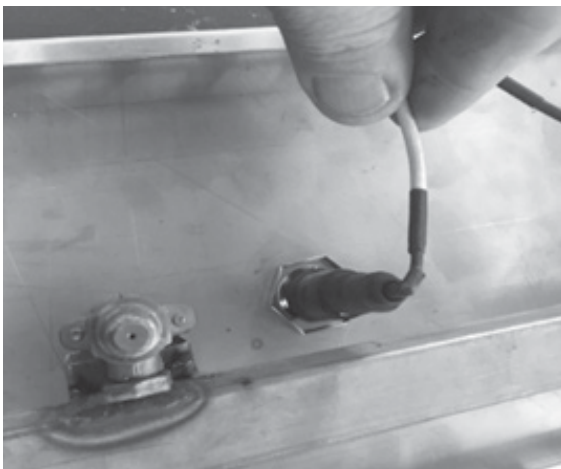

- The Wok doesn't seem to be as hot anymore? Check the burner port holes for blockages or the regulator may need changing as it is old and failing. Check the injector is not blocked.

- The burner will not light? Check the injector nipple that supplies the gas to the burner it may have a blockage.
- Control knob is stiff? Remove the knob and spray the valve shaft with unceasing lubricant then oil the shaft and replace the knob.

### TAKE CARE OF THE APPLIANCE

---

1. Clean grease collection tray after each use, check before each use. Fat/grease fires are not covered by warranty.
2. Your Wok should be cleaned regularly with hot soapy water and dried afterwards. **Do not** use steel wool as it will leave steel deposits on the surface of which can cause rust. Degreasers can be used for stubborn grease build ups or scotch bright pads but these will leave scratch marks where you have rubbed so make sure to use a fine grit pad and make sure to rub with the grain of the stainless steel. Only use these on stubborn un-washable deposits.
3. To remove rust marks, we recommend Eagle One NEVER DULL wadding polish. To prevent rust marks, polish the Wok with stainless steel polish regularly.
4. Grease or oil the gas control valve every 3 months to avoid it ceasing up in coastal salty conditions. If it becomes hard to turn then it will need an unceasing lubricant to get it moving again. If you smell gas get the Wok serviced.
5. Periodically check the lead on ignition to make sure the lead is firmly in place.
6. **Do not** attempt to dismantle control valves or the regulator.
7. Periodically remove the burner and scrub it with soapy water and a wire brush. Make sure the burner ports are clear from obstructions, dust or spiders web that may have built up. When replaced turn the burner on and check the flame pattern. You want a blue flame with a yellow tip.
8. Check the hose for kinks, leaks or perishing regularly.
9. If you cannot operate the Wok correctly turn it off. **Do not** continue to use it. Take it back to the place of purchase or local dealer and get them to test and repair it.
10. Stainless Steel can tarnish from the high temperature that the Wok burner is under, this is generally from the heat coming from the burners and will cause discolouration on the inside of the Woks Body.
11. Check and tighten nuts and bolts on the Wok body and Cabinet Trolley periodically if connected to a Tucker Cabinet Trolley.
12. A canvas cover will help keep your barbecue and Wok protected from weather. Make sure the Wok is dry before putting the cover over it or corrosion may occur from condensation especially in coastal climates which are particularly vulnerable to this.
13. We recommend service of this appliance to be done by an authorized person every two years.

**FOR SERVICE OR REPLACEMENT PARTS,  
CONTACT YOUR NEAREST DEALER OR  
VISIT: [www.tuckerbbq.com.au](http://www.tuckerbbq.com.au)**

## TUCKER WOK WARRANTY

---

### WARRANTY PERIOD

---

<b>Stainless steel body</b>	<b>5 years</b>
<b>Gas manifold</b>	<b>5 years</b>
<b>Burner</b>	<b>2 years</b>
<b>Gas control valves</b>	<b>1 year</b>
<b>Grease collection tray</b>	<b>5 years</b>
<b>Ignitions</b>	<b>1 year</b>
<b>All other parts</b>	<b>1 year</b>

### NOT COVERED

---

The warranty does not cover the purchaser or any other person for damage malfunction or loss due to the following:

- Lack of maintenance, abuse, neglect, misuse, accident, or improper installation of this appliance.
- Scratches, dents or discolouration caused by heat, abrasive or chemical cleaners.
- Damage due to grease or fat fires.
- Failure of burner and valve due to insect blockage.
- Surface rust.
- Cleaning and normal wear and tear.
- Unauthorised repairs during the warranty period.
- Removal or re-installation costs.

SERVICE CALLS OF THE ABOVE NATURE ARE CHARGEABLE

### CONDITIONS OF THIS WARRANTY

---

1. The appliance is delivered to TUCKER AUSTRALIA distributors service department or authorized service agent and freight charges both ways is to be paid by the owner. No liability is accepted for loss or damage during transit.
2. The appliance is installed by a qualified person and operated and maintained in accordance with the instructions supplied. Repairs and service must be carried out by an authorized person.
3. Installation must conform to the standards laid down by the local codes or, in the absence of local codes, with AGA code AG:601 AS:5601:2002

4. No alterations or repairs are to be carried out without obtaining the distributors prior consent. Such repair or any replacement does not extend the warranty period.
5. Proof of purchase together with this warranty must be provided to verify purchase date and establish the warranty period. Only the original purchaser is covered under this warranty.
6. Where this warranty is inconsistent with any state laws, the rights of the purchaser shall prevail.
7. Parts installed from other manufacturer's products will nullify this warranty.

### FOR YOUR RECORDS

Model:

---

Serial Number:

---

Retailer:

---

Purchase Date:

---

Gas type:

---

TUCKER AUSTRALIA PTY LTD.  
138 Silverwater Road  
Silverwater NSW 2128 AUSTRALIA.  
PHONE: (+612) 9748 8368  
FAX: (+612) 9748 8138  
WEB SITE: [www.tuckerbbq.com.au](http://www.tuckerbbq.com.au)  
EMAIL: [mail@tuckerbbq.com.au](mailto:mail@tuckerbbq.com.au)