



# DELUXE STAINLESS STEEL FLAME HEATER

Model No. FH2090DS

- The ideal solution for extending the season of outdoor entertaining
- Push button electronic ignition
- Includes a safety 'tip-over' switch that halts supply of gas to the unit should it be accidentally knocked over
- Oxygen depletion system for enhanced safety
- Complete with hose and POL regulator
- Efficient and powerful 33MJ/h output
- Adjustable heat output
- Operates for approximately 14 hours on a properly filled 9Kg Propane cylinder
- For outdoor use only
- Gas certified to Australian standards

## FOR YOUR SAFETY

If you smell gas:

1. Shut off the gas to the appliance.
2. Extinguish any open flame.
3. If odour continues, immediately call your gas supplier.

Do not store or use gasoline or other flammable vapour and liquids in the vicinity of this or any other appliance.

## WARNING

Improper installation, adjustment, alteration, service or maintenance can cause injury or property damage.

Read the instructions thoroughly before installing or servicing this equipment.

## FOR OUTDOOR USE ONLY

## PROPANE GAS



---

**Important: Retain these instructions for future use**

---

# INSTALLATION, OPERATION & MAINTENANCE INSTRUCTIONS



## IMPORTANT SAFETY RULES

This appliance must only be used in a well ventilated area.

1. This appliance shall not be installed or used indoors, in buildings, garages or any other enclosed area.
2. **DO NOT** place articles on or against this appliance.
3. **DO NOT** use or store flammable materials near this appliance.
4. Children and adults should be alerted to the hazards of high surface temperatures, burns and clothing ignition.
5. Children should be carefully supervised when they are in the area of the appliance.
6. **NEVER** hang anything including clothes or other flammable items on the appliance.
7. **DO NOT** operate this appliance unless it is fully assembled with burner guard in place.
8. **DO NOT SPRAY AEROSOLS IN THE VICINITY OF THIS APPLIANCE WHILE IT IS IN OPERATION.**
9. Installation and repair should be done by a qualified service person. The appliance must be inspected before use and at least annually by a qualified service person. More frequent cleaning may be required as necessary. It is imperative that control compartment, burners and circulating air passages of the heater and light be kept clean.

Prior to assembling your appliance, the following must be reviewed. Compliance with the following should result in satisfactory heater operation. This instruction manual should be retained for future reference. The installation must conform with local codes or authority having jurisdiction.

1. The appliance is intended for heating residential and non-residential outdoor spaces. The installation must conform with local codes or, in the absence of local codes, with the Australian Standard AS 5601.
2. Adequate clearance around air openings into the combustion chamber, clearances from combustible materials, provisions for accessibility and for combustion and ventilating air supply must be maintained at all times when the appliance is operating.
3. Proper clearance from combustible materials must be maintained at all times. The minimum clearances are as follows:

### Minimum Clearance from Combustibles

**Side** 650 mm

**Rear** 650 mm

**Ceiling** 800 mm

Combustible materials are considered to be wood, compressed paper, plant fibres, plastic, plexiglas or other materials capable of being ignited and burned.

Such materials shall be considered combustible even though flame proofed, fire-retardant treated or plastered. Additional clearance may be required for glass, painted surfaces and other materials which may be damaged by radiant or convection heat.

4. Heaters must be placed on a level and adequate footing and be readily accessible.
5. The gas manifold supply pressure must be regulated at 2.75 kPa utilising an AGA approved regulator (supplied with heater).
6. The appliance must be inspected before each use, and at least annually by a qualified service person.
  - a. The appliance area must be kept clear and free of combustible materials, gasoline and other flammable vapours and liquids.
  - b. Gas orifices and burner must be kept clear of dirt and cobwebs. Flow of combustion and ventilation air through the perforated portions of the heater must not be obstructed. Cleaning with a soft brush before use and at least every six months is recommended.
  - c. After assembly and before use all gas connections should be checked for leaks utilising a soap solution. **NEVER** use a flame for this purpose.

For any queries or assistance call



**Customer Service**  
Australia Only  
**1300 174 876**

Hours of operation:  
Monday to Friday 8am - 5pm EST

Do not return to place of purchase.

- d. The flame should be visually checked whenever heater is operated. If flames extend beyond surface of the chimney or black spot is accumulating on the burner or glass, the heater should be turned off immediately. The heater should not be operated again until the unit is serviced and or repaired.
- e. Any cleaning agent used on the appliance should be of a non-combustible and non-corrosive nature.
7. The hose assembly should be properly located out of pathways where people may trip over it. The hose must be protected from contact with hot or sharp surfaces both during use and while in storage. The hose assembly should be visually inspected prior to each use of the heater. If excessive abrasion or wear is evident, or the hose is cut, it must be replaced prior to operating the heater. The replacement hose assembly may be obtained from the manufacturer.
8. **DO NOT** use any pressure regulator or hose assembly other than those supplied with the appliance. Replacement pressure regulator and hose assembly must be those specified. Replacement parts may be obtained from the manufacturer or your local sales representative.
9. Installation and use of this appliance must conform with local codes or, in the absence of local codes, with the Standards of Storage and Handling of Liquefied Petroleum Gases.
10. This appliance is designed to operate with a standard 9Kg propane cylinder with Approved Cylinder Connection.
11. The valve outlet must be maintained in good condition. When the cylinder is not in use, be sure to cover it with a dust cap. A leak test should be performed with soapy water whenever connecting a new cylinder. **NEVER** use a match to test for leaks.
12. The propane cylinder must be turned off whenever the heater is not in use. When the heater is to be stored indoors, the propane cylinder and the heater must be disconnected and the cylinder stored in accordance with the Standard for Storage and Handling of Liquefied Gases. (i.e.: Not indoors, but in a dry and well ventilated area.)
13. The heater has been designed with several safety features which include a tip over switch.

Any modification to the heater not described in the installation instructions may compromise the safety of this appliance. Special concern is as follows:

DO NOT bypass thermocouple safety;

Clothing or other flammable materials should not be hung from the heater, or placed on or near the heater. The area above may be extremely hot. Direct contact with these metal surfaces should be avoided in order to prevent burns or clothing ignition.

## POL CYLINDER CONNECTION DEVICE

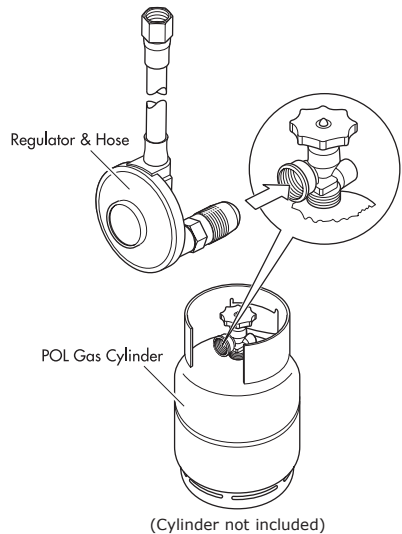









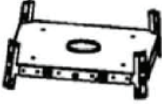
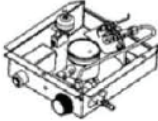



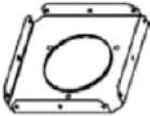

Screw the coupling nut of regulator into the cylinder valve outlet.

Type of Gas	Propane
Consumption	33 MJ/h
Operating Pressure	2.75 kPa
Injector Size	1.6 mm

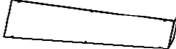
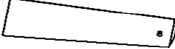
Heater specifications can be found on the data label.

# PARTS LIST

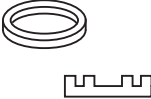
<p>1. Middle Plate 1pc</p> 	<p>2. Control Box 1pc</p> 	<p>3. Bottom Panel 1pc</p> 	<p>4. Lower Support Leg 4pcs</p>  <p>80cm Long Rubber Foot</p>	<p>5. Upper Support Post 4pcs</p> 
<p>6. Upper Plate 1pc</p> 	<p>7. Lower Plate 1pc</p>  <p>Pre-assembled in Middle Plate</p>	<p>8. Glass Tube 1pc</p>  <p>With o ring fitted</p>	<p>9. Radiant Head 1pc</p>  <p>Pre-assembled in Upper Plate</p>	<p>10. Reflector 1pc</p> 
<p>11. Protection Guard 4pcs</p> 	<p>12. Guard Fixing Bracket 4pcs</p> 	<p>13. Side Panel 3pcs</p> 	<p>14. Front Panel 1pc</p> 	<p>15. Screw 67pcs</p>  <p>All pre-assembled in relative parts</p>
<p>16. Knob 1pc</p> 	<p>17. Chain 1pc</p>  <p>Pre-assembled in the front knob</p>	<p>18. AA Battery 1pc</p>  <p>NOT INCLUDED</p>	<p>17. Bottom o ring for glass tube</p> 	

# ASSEMBLY INSTRUCTIONS

Note: Remove any transit protection material.

Tools required: Phillips head screw driver and 2 adjustable spanners.

## STEP 1

The lower support leg has a rubber foot at the bottom. Remove the five screws from each leg, using them to attach the bottom panel and middle plate from the inside.

Ensure the magnets on the side of the middle plate are aligned with the 'T' shaped holes on the side of the bottom panel.

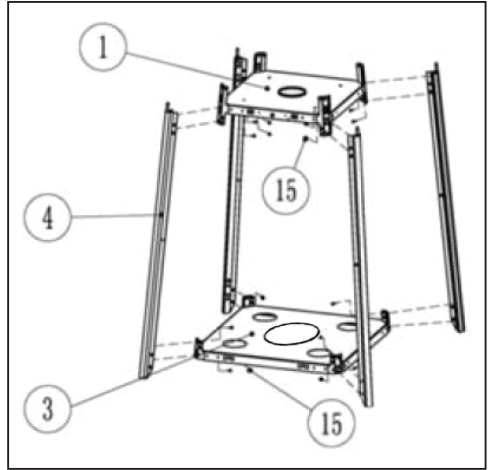

## STEP 2

Remove the screws from each of the upper support posts, using them to attach to the middle plate from the inside.

Remove the screws from the radiant head, using them to attach it to the upper posts from the outside.

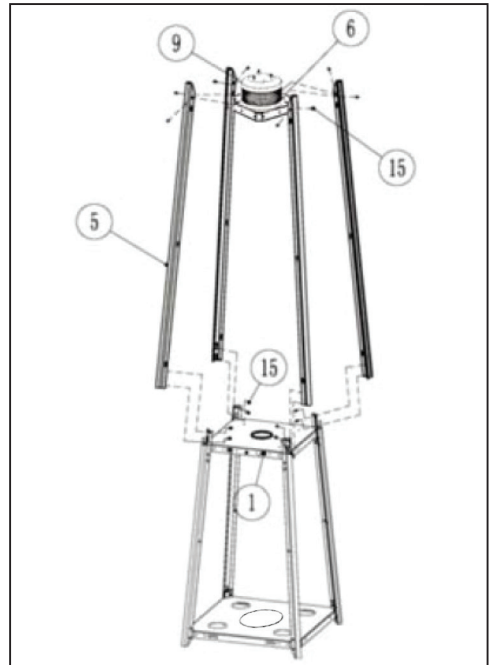

### STEP 3

Attach the control box to the underside of the middle plate with the controls facing the magnets, using 4 screws from underneath.

Unscrew and remove the igniter cap, insert a 'AA' battery with the + facing outwards, then re-attach the cap.

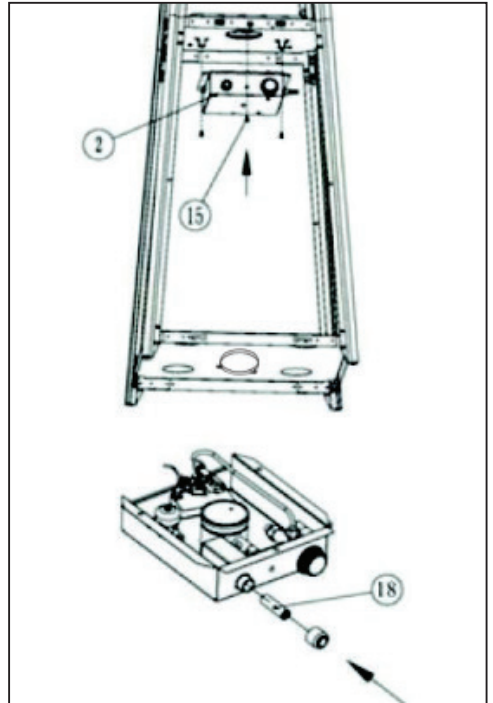

### STEP 4

Ensure direction of middle fitted o ring on glass tube is as per image.

Push glass tube into top radiant head.

Fit bottom o ring to glass tube.

Lower glass tube with bottom o ring into burner box.

Slide middle fitted o ring down to gap between glass tube and middle plate as per image.

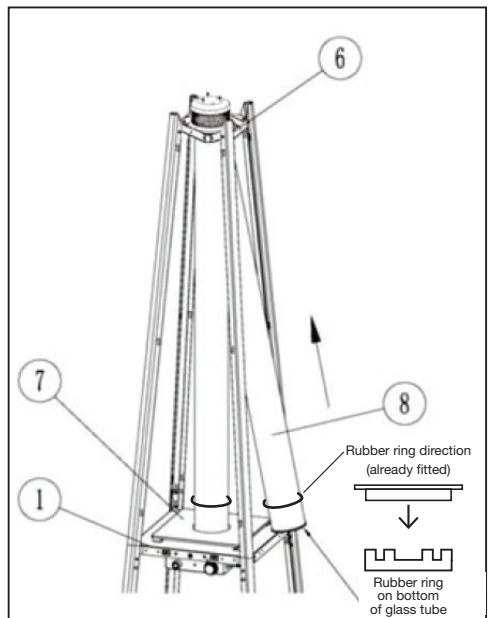
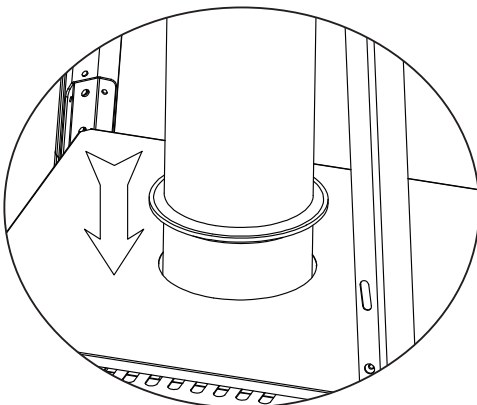

### STEP 5

Attach the reflector to the studs on the radiant head using the washers and wing nuts supplied.

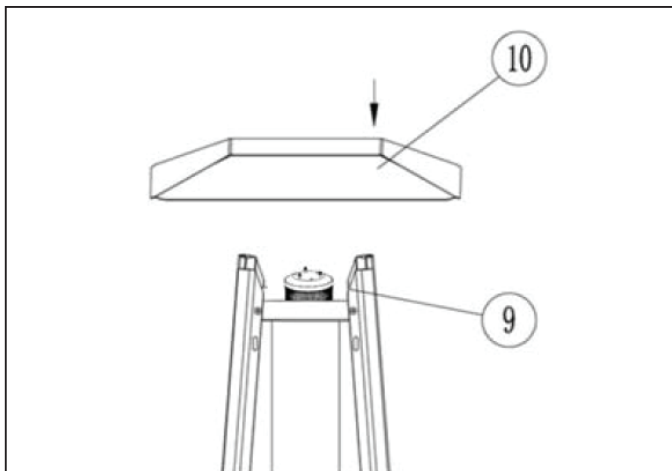

### STEP 6

Attach the side and back panels using the 4 screws supplied per panel.

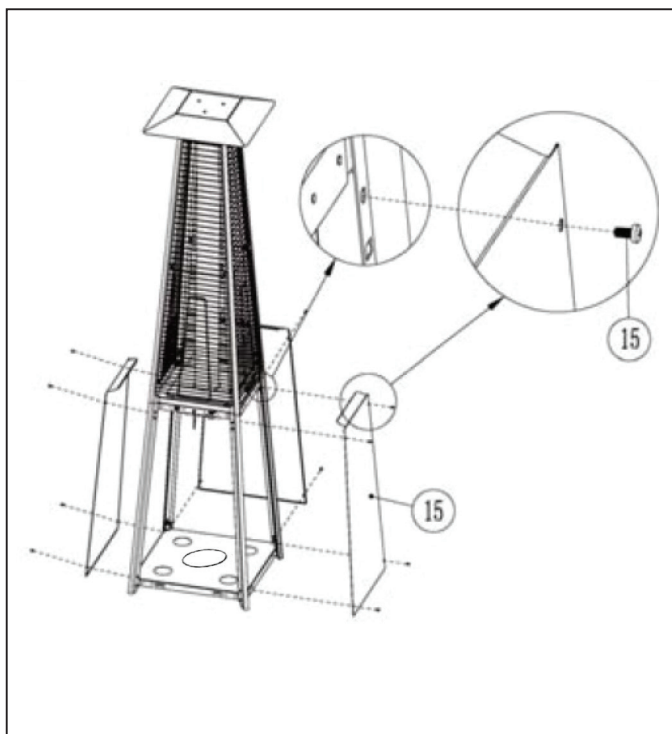

## STEP 7

Attach the guards by aligning the hooks with the slots in the upper support posts and secure at the top with the bracket and screw supplied.

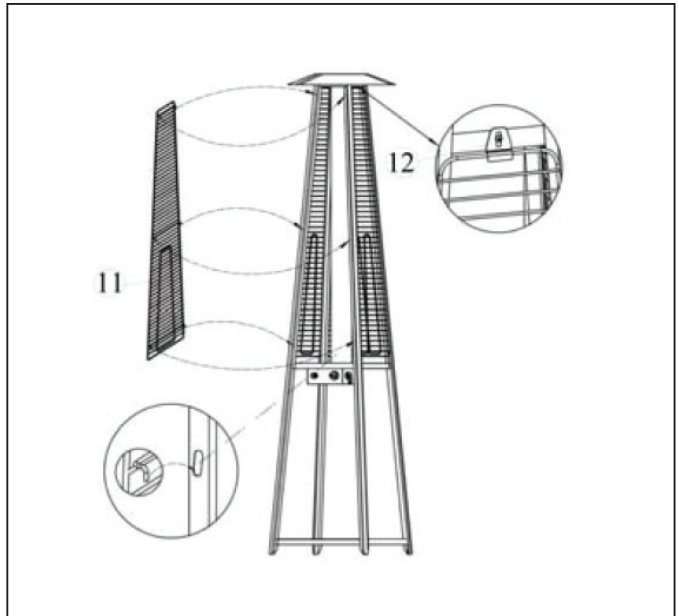

## STEP 8

Attach the knob to the outside top of the door panel with the chain on the inside. The bent tabs at the bottom are positioned into the 'T' shaped holes in the bottom panel and held at the top with magnets.

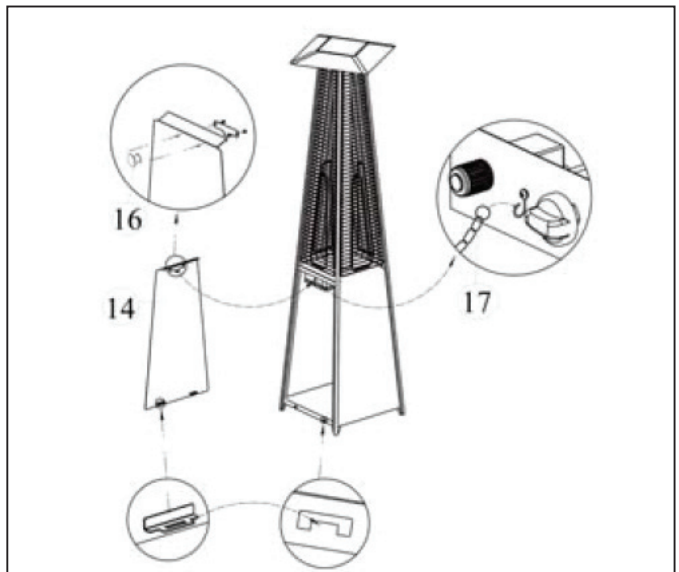



# OUTDOOR FLAME HEATER - FOR OUTDOOR USE ONLY

## Minimum Clearance from Combustible Surfaces\*:

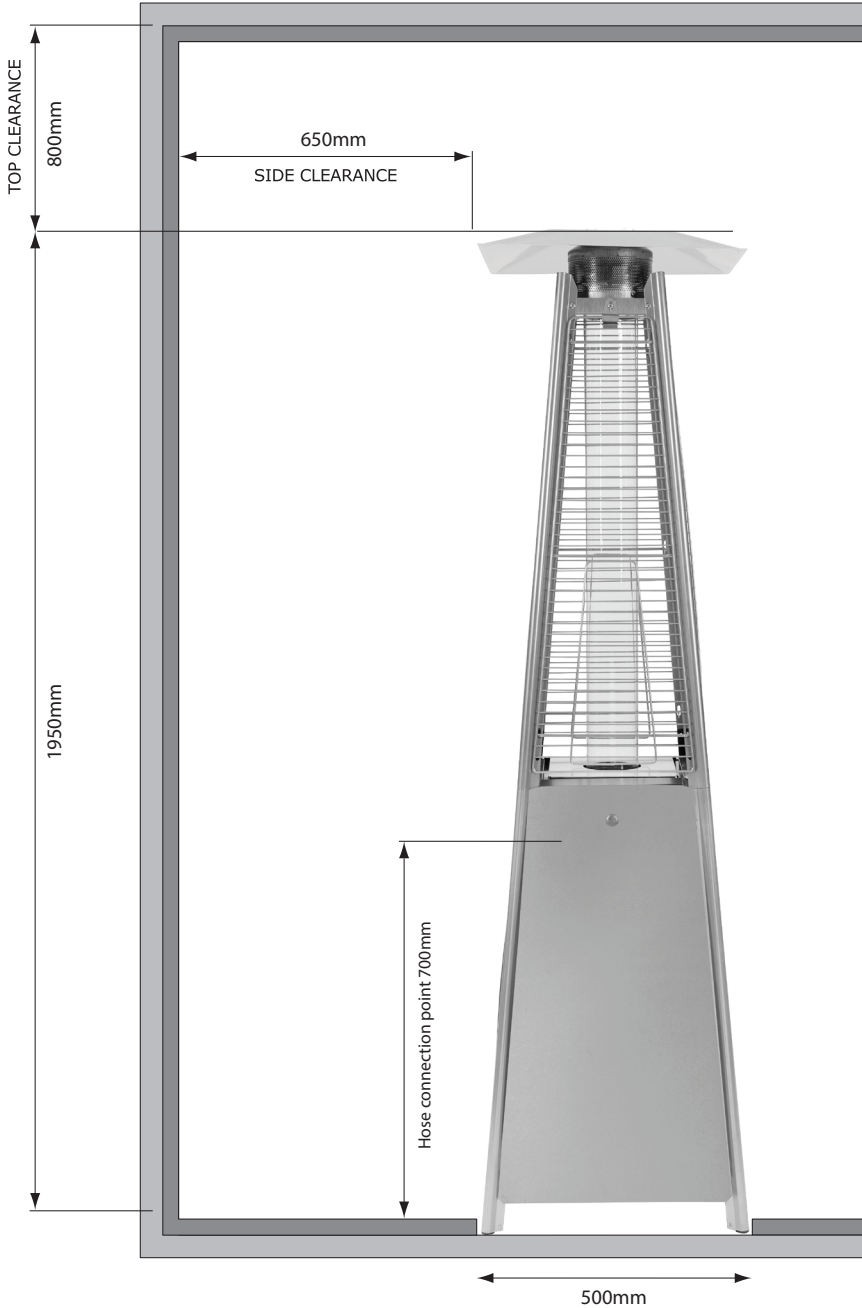

\*Combustible materials are considered to be wood, compressed paper, plant fibres, plastic or other materials that are capable of being ignited and burned.

## OPERATION

Connect hose POL to cylinder and leak test before use

(Cylinder not included)

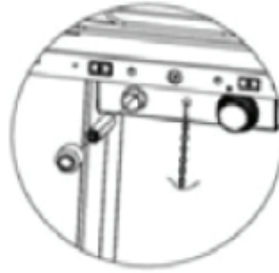
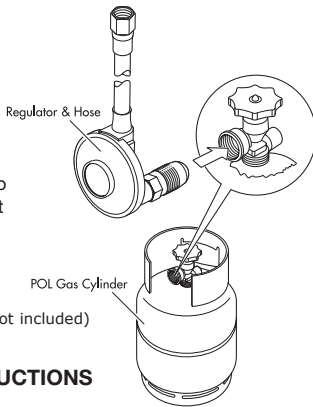

Insert a 'AA' battery with the '+' facing outwards.

## LIGHTING INSTRUCTIONS

### STEP 1

Ensure that the control knob is OFF. Slowly open the gas cylinder valve.

### STEP 2

Press and turn the control knob to LIGHT position, push the igniter to generate spark while keeping control knob pressed in.

### STEP 3

Check for the pilot flame through glass tube. If pilot does not light, turn control knob to OFF position, wait two minutes minimum and try again. Several attempts may be necessary.

### STEP 4

If the pilots alight, keep the control knob pressed for 15 seconds then turn the control knob to LOW.

### STEP 5

For maximum heat turn control knob to HIGH.

### STEP 6

To turn heater off, turn the control knob to OFF.

### STEP 7

Close the valve of the gas cylinder clockwise to OFF after use.

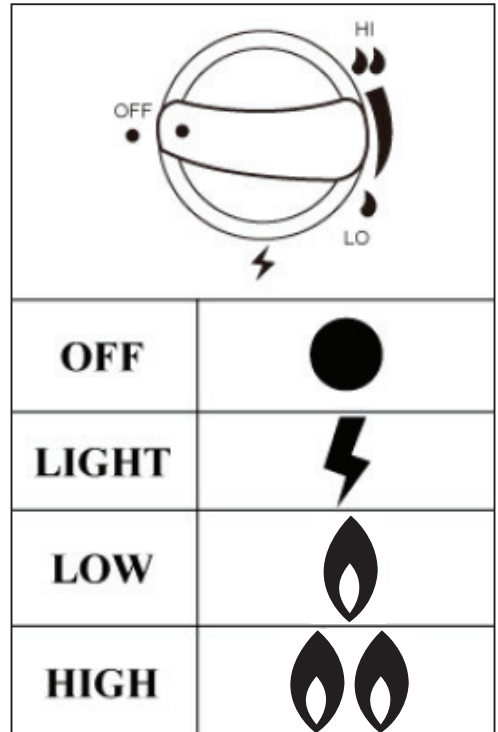

## WARNING

- Never use the heater while it is raining, the glass tube will break.
- The glass tube will be extremely hot when operating, never try to touch it and keep children away from the heater.
- Always ensure the heater is seated firmly, the glass tube may break if the heater falls.
- Never use the heater if the glass tube has any crack or damage.
- THE GUARD IS FITTED TO THIS APPLIANCE TO REDUCE THE RISK OF FIRE OR INJURY FROM BURNS AND NO PART OF IT SHOULD BE REMOVED.
- ANY GUARD OR OTHER PROTECTIVE DEVICE REMOVED FOR SERVICING THE APPLIANCE MUST BE REPLACED PRIOR TO OPERATING THE APPLIANCE.

## TROUBLE SHOOTING

Problem	Possible Causes	Solution
Main burner will not light	Gas valve may be OFF	Turn the gas valve ON
	LPG cylinder empty	Refill LPG cylinder
	Orifice blocked	Clean or replace orifice
	Air in supply system	Purge air from lines
	Loose connection	Check all fittings
Pilot will not stay on	Debris around pilot	Clean dirty area
	Loose connection	Check all fittings
	Thermocouple faulty	Replace thermocouple
	Gas leak in line	Check connections
	Lack of gas pressure	LPG cylinder is near empty
	Gas pressure is low	LPG cylinder is near empty
	Orifice blocked	Remove, clean and replace
	Control knob not ON	Turn knob to ON
	Thermocouple faulty	Replace thermocouple
Pilot light assembly bent or not in correct location	Place pilot light in correct position and retry	

Note: Any repairs to the heater must be carried out by a qualified person or service agent.

# SAFE APPLIANCE LOCATIONS

This appliance shall only be used in an above ground open-air situation with natural ventilation, without stagnant areas, where gas leakage and products of combustion are rapidly dispersed by wind and natural convection.

**Any enclosure in which the appliance is used shall comply with one of the following:**

An enclosure with walls on all sides, but at least one permanent opening at ground level and no overhead cover (see Example 1).

Within a partial enclosure that includes an overhead cover and no more than two walls (see Example 2 & 3).

**Within a partial enclosure that includes an overhead cover and more than two walls, the following will apply:**

At least 25% of the total wall area is completely open, and

At least 30% of the remaining wall area is open and unrestricted (see Example 4 & 5).

In the case of balconies, at least 20% of the total wall area shall be and remain open and unrestricted.

The following figures are diagrammatical representations of outdoor areas. Rectangular areas have been used in these figures - the same principles apply to any other shaped area.

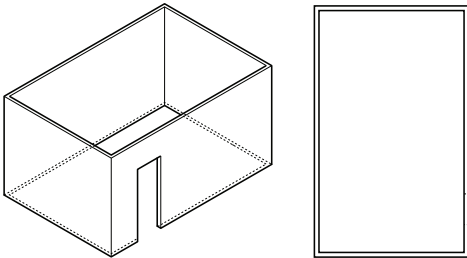

**Outdoor Area - Example 1**

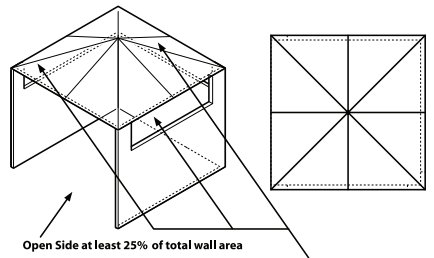

Open Side at least 25% of total wall area  
30% or more in total of the remaining wall area is open and unrestricted

**Outdoor Area - Example 4**

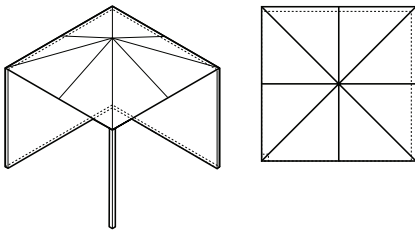

**Outdoor Area - Example 2**

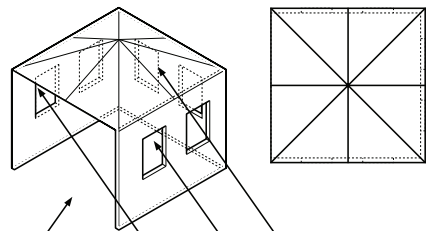

Open Side at least 25% of total wall area  
30% or more in total of the remaining wall area is open and unrestricted

**Outdoor Area - Example 5**

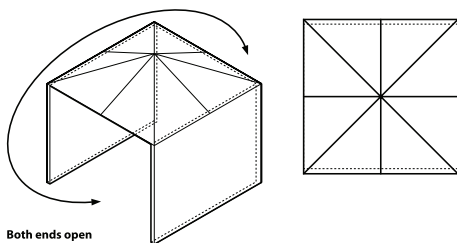

Both ends open

**Outdoor Area - Example 3**