

GRANGE & ROYAL GAS LOG SPACE HEATERS

COONARA
The Warmest Aussie Legend



Up to 5.1 star energy rating





The Warmest Aussie Legend

We have been proudly manufacturing in Australia for over 35 years.

Woodheaters have been the key to our business growth since the mid 1980's. Over the years our manufacturing of Woodheaters has employed hundreds of locals and contributed significantly to the local community - this is something we are extremely proud of. The acquisition of the Coonara brand in 2001 was made possible due to our earlier success in our contract manufacturing of Woodheaters and we are really excited about the newly introduced technologies that deliver Coonara Gas Log Heaters with high efficiency heating. This is a major step in the right direction for our environment.

Of course none of our success could be achieved without the support and dedication of our fantastic staff. We are a proud Australian manufacturer and we are proving that locally manufactured products can successfully compete with imported products. Your support is critical in helping keep the Australian manufacturing industry safe. We thank you for your continued support of Australian made Coonara Gas Log Heaters. They really are an Aussie icon.

Yours sincerely

Eric Woodgate
Managing Director



COVER: **ROYAL DOMAIN** INBUILT GAS LOG HEATER

The stylish and modern Royal Domain Inbuilt Gas Log Heater has a new fascia whilst maintaining the high star energy rating and heating an area of up to 20 squares.

ROYAL FREESTANDING GAS LOG HEATER



Features:

- 83% efficiency rating
- 4.6 Stars energy rating
- Heats up to 20 squares
- 8 colour options*
- Flueing options
- Thermostat controller
- 37MJH on High
- 19MJH on Low
- Heat output:
High – 8.7KW
Low – 4.3KW
- Natural Gas only

Smart phone app available. See page 12 for details.

Heater Dimensions:

- Height: 640mm
- Width: 775mm
- Depth: 430 mm

3



4.6 star energy rating



ROYAL PEDESTAL GAS LOG HEATER



*For colour options refer to page 12.

Features:

- 83% efficiency rating
- 4.6 Stars energy rating
- Heats up to 20 squares
- Colour P/C White
- Flueing options
- Thermostat controller
- 37MJH on High
- 19MJH on Low
- Heat output:
High – 8.7KW
Low – 4.3KW
- Natural Gas only

Overall Dimensions:

- Height: 1035mm
- Width: 775mm
- Depth: 430 mm

Heater Dimensions:

- Height: 640mm
- Width: 775mm
- Depth: 430 mm

Smart phone app available. See page 12 for details.

ROYAL SLIMLINE



Pictured with Charcoal Fascia

Available in a variety of colours:

- Charcoal
- Black
- Golden Fire Brown
- Honey Glo
- Titanium
- Pewter
- Blue
- Stainless Steel

See page 12 for colour details. Natural Gas only. Pictured with black fascia.

Overall Dimensions:

- Height: 680mm
- Width: 860 mm
- Depth: 450mm



4.6 star energy rating



ROYAL TABLETOP



Pictured on a Black Tabletop. *For colour options refer to page 12.

Features:

- 83% efficiency rating
- 4.6 Stars energy rating
- Heats up to 20 squares
- Flueing options
- Thermostat controller
- 37MJH on High
- 19MJH on Low
- Heat output:
 - High – 8.7KW
 - Low – 4.3KW
- Natural Gas only

Tabletop Dimensions:

- Height: 400mm
- Width : 1200mm
- Depth : 555mm

Smart phone app available. See page 12 for details.

VICTORIAN ROYAL

INBUILT GAS LOG HEATER

Features:

- 83% efficiency rating
- 4.6 Stars energy rating
- Heats up to 20 squares
- 8 colour options*
- Flueing options
- Thermostat controller
- 37MJH on High
- 19MJH on Low
- Heat output:
High – 8.7KW
Low – 4.3KW
- Natural Gas only

Smart phone app available. See page 12 for details.



4.6 star energy rating





The Warmest Aussie Legend

ONE OF THE MOST **POWERFUL & EFFICIENT** GAS LOG SPACE HEATERS

A highly powerful 5 star rated gas log heater that heats up to 20 squares*.

The Coonara Grange gas log space heater has an optional air transfer system with heat coming directly from around the heat exchanger.

Pictured with a Chrome Frame (Optional Extra)



5.1 star energy rating



GRANGE

FREESTANDING & INBUILT GAS LOG HEATER



BLUE METALLIC

(Pictured with optional chrome frame)



HONEY GLO





The Warmest Aussie Legend

GRANGE FREESTANDING GAS LOG HEATER

ONE OF THE MOST **POWERFUL & EFFICIENT** GAS LOG SPACE HEATERS

The Coonara Grange is a heater for homeowners who appreciate the beauty of woodheating with the ease of gas log heating.

The Coonara Grange Gas Log Space Heater comes with a Thermostat Controller as standard, which allows you to control the room temperature to suit your comfort levels on these cold, chilly nights.

A highly powerful 5 star rated gas log heater that heats up to 20 squares*

Available in a variety of colours:

- Charcoal
- Black
- Golden Fire Brown
- Honey Glo
- Titanium
- Pewter
- Blue
- Stainless Steel

See page 12 for colour details.



GRANGE FREESTANDING GAS LOG

Pictured with a cover box and 6" round flue pipe + Chrome Trim (optional).



5.1 star energy rating



AUSTRALIAN MADE®



GRANGE DOMAIN

INBUILT GAS
LOG HEATER



GRANGE SLIMLINE



UP TO 8 STANDARD COLOUR OPTIONS PLUS POWDER COATED MODELS

	Charcoal		Golden Fire Brown
	Black		Pewter
	Blue		Titanium
	Honey Glo		Stainless Steel

* Provided there is Internet connection. **Compatible devices:** Requires iOS 7.0 or later; iPod touch (5th generation & later); iPhone (5 & later); iPad (all models). Download on the App Store or Android App on Google Play or download from Windows Store.



The Grange Slimline can be installed into an existing fireplace or a purpose built surround with convenient flueing options. The Grange Slimline range has an optional Heat Transfer Kit and comes with the Thermostat Controller as standard. Featured here in Charcoal.

COONARA FIREPLACE THERMOSTAT APP

Allows you to control your fireplace from your iPod, iPhone and iPad

With this Optional Extra application you can:

1. Control the temperature from anywhere*
2. Adjust the flame settings from anywhere*
3. Turn on and off times via the 7 day programmable times
4. Listen to the built in wood fire sound effect
5. Simultaneously control your fireplace from multi iOS devices
6. Easily format units of measure for temperature (celsius & fahrenheit)
7. Easily format time display: 12 hour & 24 hour



GRANGE FREESTANDING GAS LOG HEATER



Pictured here in a charcoal finish on a concrete bench. *For colour options refer to page 12.

Features:

- 86.5% efficiency rating
- 5.1 Stars energy rating
- Heats up to 20 squares
- 8 colour options
- Flueing options
- Thermostat controller
- 37MJH on High
- 19MJH on Low
- Heat output:
High – 8.7KW
Low – 4.3KW
- Natural Gas & L.P.G.

Smart phone app available. See page 12 for details.



5.1 star energy rating



GRANGE PEDESTAL GAS LOG HEATER



Pictured in P/C Blue. *For colour options refer to page 12.

Features:

- 86.5% efficiency rating
- 5.1 Stars energy rating
- Heats up to 20 squares
- 8 colour options
- Flueing options
- Thermostat controller
- 37MJH on High
- 19MJH on Low
- Heat output:
High – 8.7KW
Low – 4.3KW
- Natural Gas & L.P.G.

Smart phone app available. See page 12 for details.

Overall Dimensions:

- Height: 1035mm
- Width: 775mm
- Depth: 430mm



5.1 star energy rating



GRANGE TABLETOP



Pictured in a Charcoal finish on the Tabletop. *For colour options refer to page 12.

Features:

- 86.5% efficiency rating
- 5.1 Stars energy rating
- Heats up to 20 squares
- 8 colour options
- Flueing options
- Thermostat controller
- 37MJH on High
- 19MJH on Low
- Heat output:
High – 8.7KW
Low – 4.3KW
- Natural Gas & L.P.G.

Tabletop Dimensions:

- Height: 400mm
- Width: 1200mm
- Depth: 555mm

Smart phone app available. See page 12 for details.



5.1 star energy rating



GRANGE

INBUILT VICTORIAN



The Coonara Grange Victorian is a heater for homeowners who appreciate the beauty of woodheaters with the ease of gas log heating. The Coonara Grange and Royal Victorian comes with a thermostat controller as standard, which allows you to control the room temperature to suit your comfort levels on cold, chilly nights.

Where tradition meets innovation.

- 86.5% efficiency rating
- 5.1 star energy rating
- Heats up to 20 squares
- Colour: Black



5.1 star energy rating



FRAMING SPECIFICATIONS NO FIREPLACE NECESSARY

ROYAL & GRANGE HEATING AREA*

Up to 20 squares*, based on open plan living area with 2.4 metre ceiling height. Note: Lack of insulation, large glass areas and cathedral ceilings reduce heating performance.

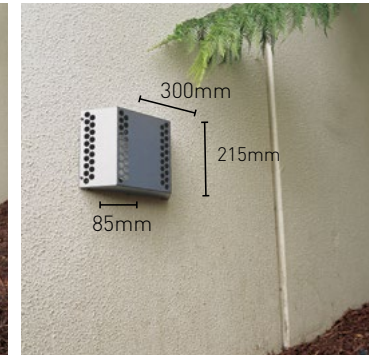
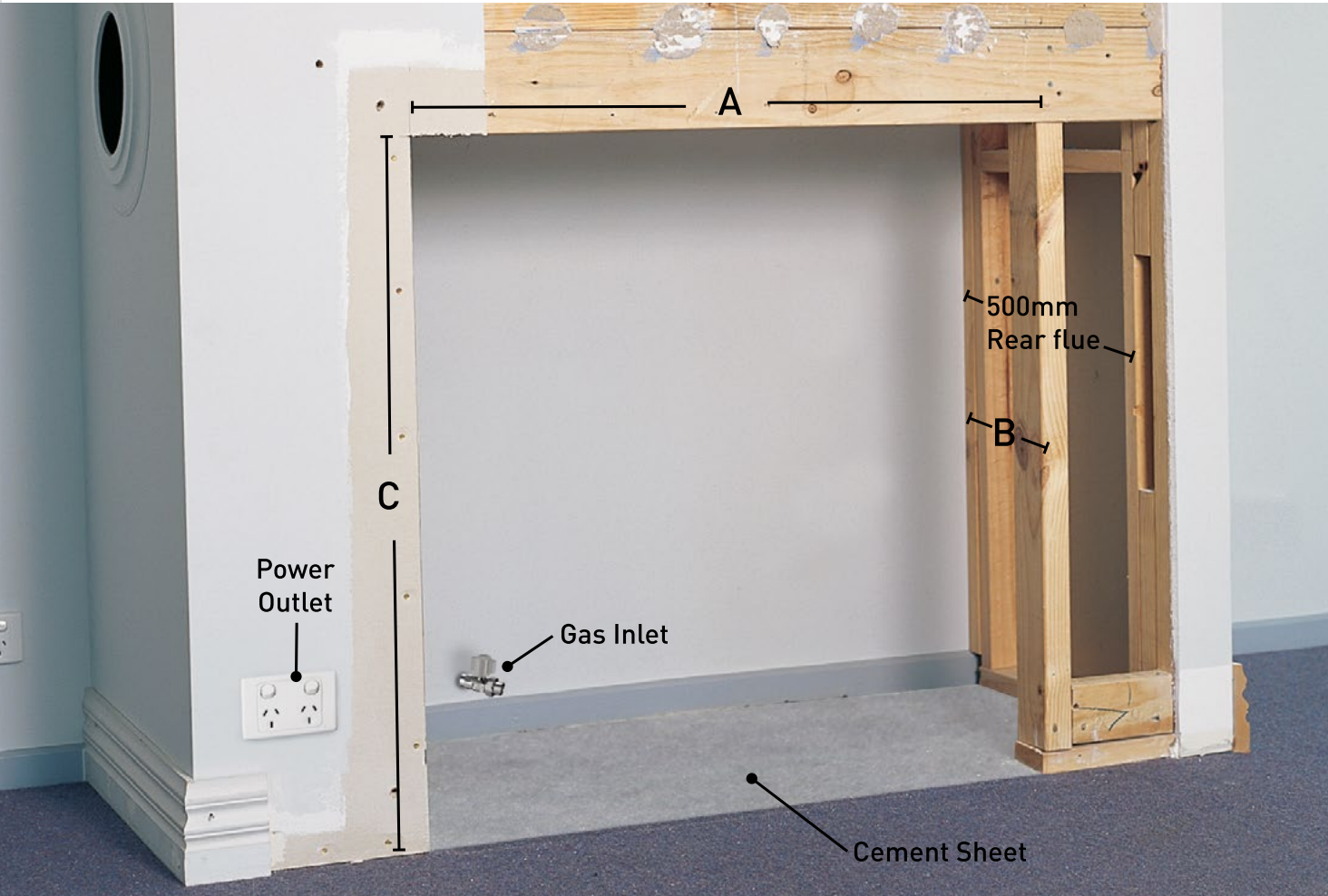

External weather cover with cowl for Grange installed through the wall. (External Installation - Inbuilt)
Grange Inbuilt: 290mm Depth
Grange/Royal: 390mm Depth

Flue cowl attached to external wall with Grange installed into stud wall cavity.

OPTIONAL AIR TRANSFER SYSTEM

The Coonara Grange and Royal gas log space heaters have an optional air transfer system with heat coming directly from around the heat exchanger. This effectively means you can heat two areas from the one heater. Heat transfer kit includes 1 x inline fan, 1 x adaptor box.

Note: Ducting and register not included in kit.

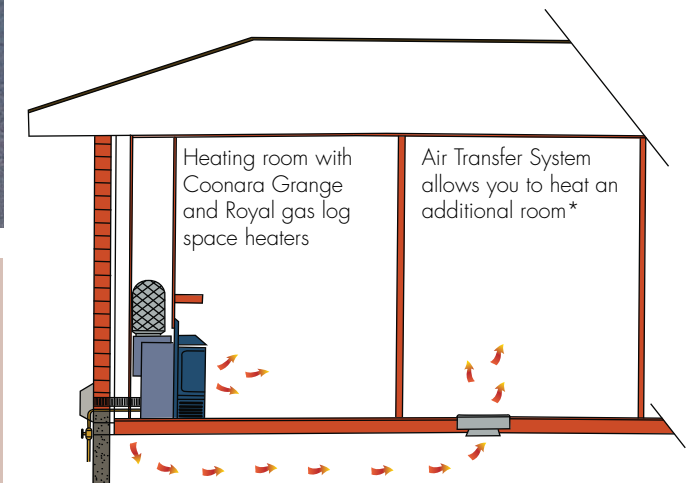

GRANGE
A) 750mm
B) 400mm
C) 650mm

GRANGE DOMAIN & SLIMLINE
A) 750mm
B) 600mm
C) 650mm

ROYAL DOMAIN & SLIMLINE
A) 750mm
B) 600mm
C) 650mm

- Gas Inlet to be 1/2" FEM BSP
- Power Outlet left hand side
- Cement Sheet required (for flat level base)

FLUE INSTALLATION

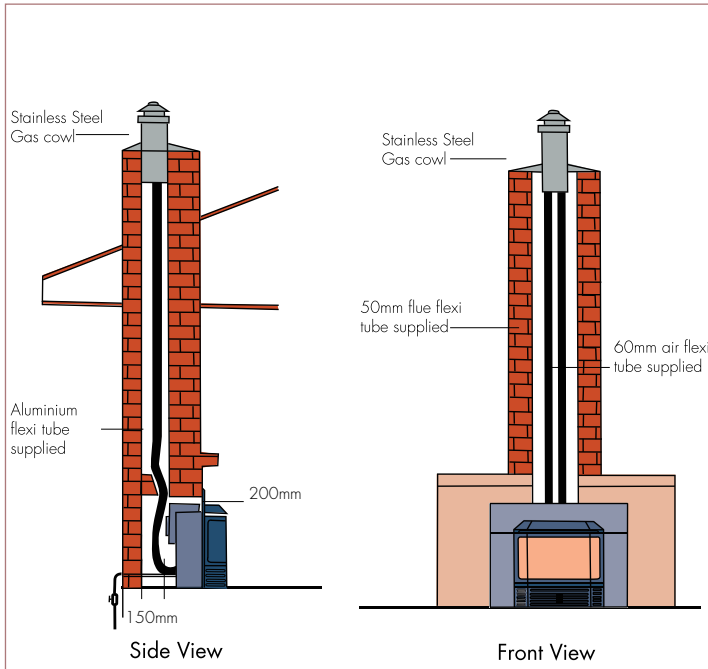

- Ability to control room temperature – maximising comfort and energy savings
- Programmable heating levels to enhance comfort control
- Large easy to read backlit LCD screen
- Factory fitted
- Powered by 2x AA batteries for approximately 12 months of operation
- Full seven-day program capability

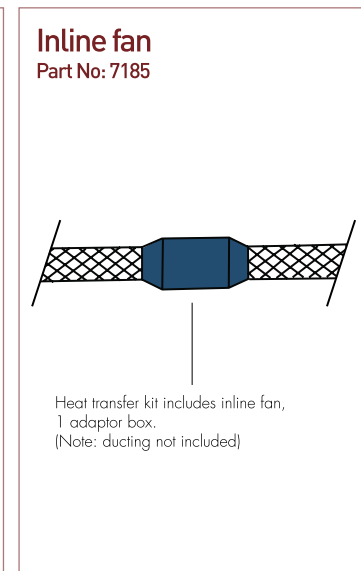
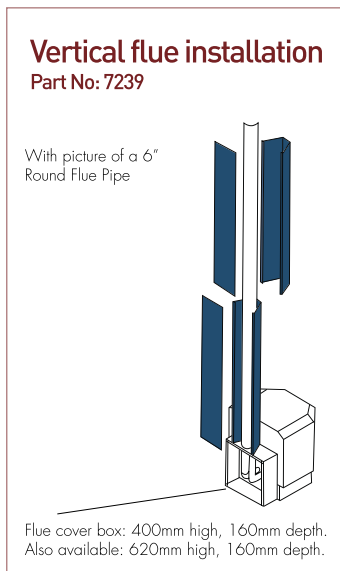
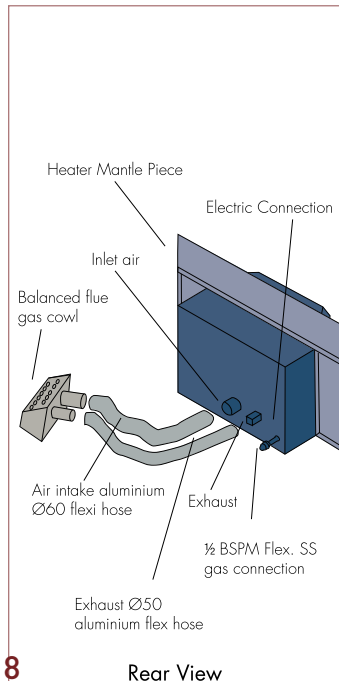
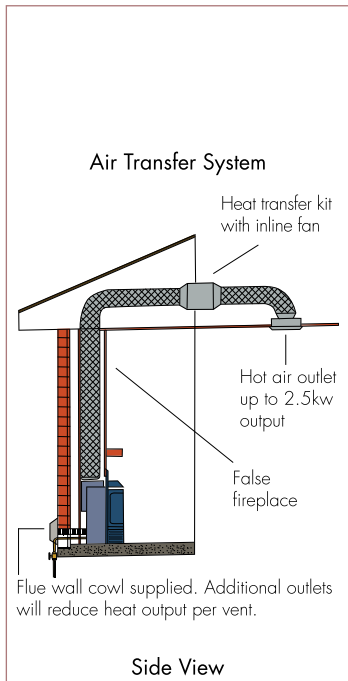
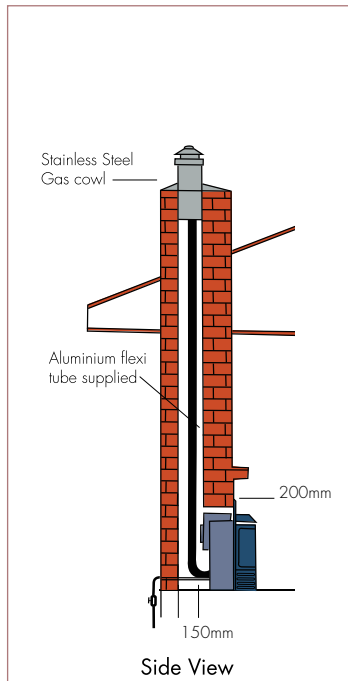
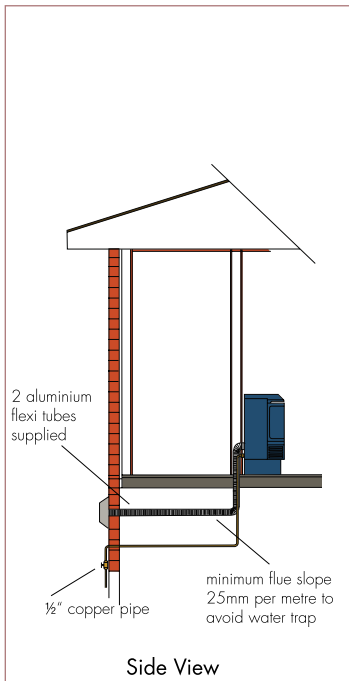
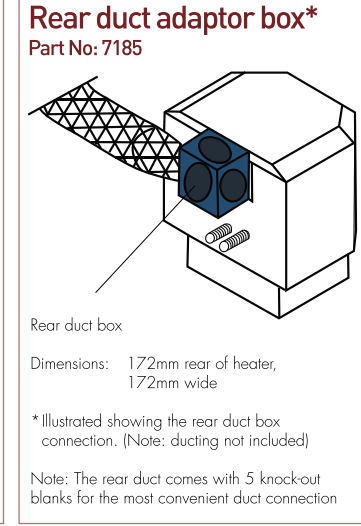
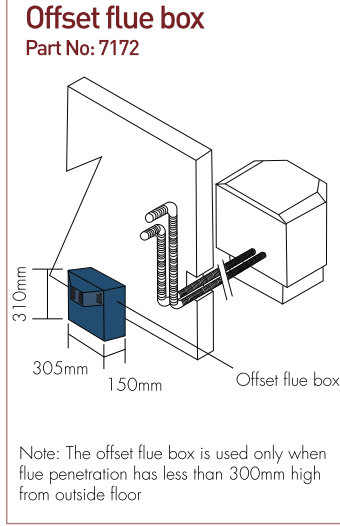
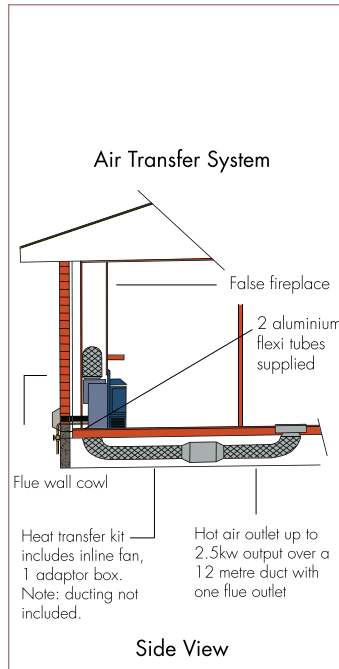

ROYAL TECHNICAL SPECIFICATIONS

Tested and approved

Tested and approved to the most stringent quality standards for safety and efficiency. AGA approved. Certificate No. 7048G.

Coonara Warranty

All current Coonara gas heaters are warranted to be free from defects in material and workmanship under normal use and service. The warranty of the actual firebox and heat exchanger is 5 years – to the initial purchaser. All other components (except accidental breakage of door glass) are warranted for a period of 24 months. Coonara gas log fires are designed and tested for use with Coonara manufactured flue kits. For the full warranty statement, refer to the Shamic Sheetmetal (Aust) P/L website (www.shamic.com.au), the product installation manual, or your Coonara dealer. Shamic goods come with guarantees that cannot be excluded under Australian Consumer Law. The purchaser is entitled to a replacement or a refund for a major failure and compensation for any reasonably foreseeable loss or damage. The purchaser is also entitled to have the goods repaired or replaced if the goods fail to be of acceptable quality and the failure does not amount to a major failure. All heaters pictured in this brochure are operating on Natural Gas. Flame patterns are different on LPG.

Note: All Coonara heaters must be installed by our authorised installer to be covered by our warranty statement.

***IMPORTANT: Heating areas provided are based on open plan living areas and 2.4 metre ceiling height. Note: Lack of insulation, large window areas and cathedral ceilings reduce heating effectiveness.**

		ROYAL DOMAIN	ROYAL SLIMLINE + VICTORIAN	ROYAL FREESTANDING & PEDESTAL
HEATING CAPACITY UP TO SQUARES SQUARE METRES*		20 200	20 200	20 200
EFFICIENCY RATING		83%	83%	83%
STAR RATING		4.6	4.6	4.6
CAST IRON FASCIA DIMENSION (mm) & MODEL			990x1130 (600)	
FIRE BOX	HEIGHT (mm) WIDTH (mm) DEPTH (mm)	600 705 430	600 705 430	640 775 430
OVERALL DIMENSIONS	HEIGHT (mm) WIDTH (mm) DEPTH (mm)	680 860 450	680 860 450	1035 775 430
FASCIA DEPTH (MM)		40	20	N/A
FLUEING OPTIONS	VERTICAL HORIZONTAL UNDER FLOOR	YES YES YES	YES YES YES	YES YES YES
THERMOSTAT CONTROLLER		STANDARD	STANDARD	STANDARD
HEAT TRANSFER KIT		OPTIONAL	OPTIONAL	NO
NATURAL GAS ONLY		YES	YES	YES
DESPATCH WEIGHT (KG)		90	90	84
GAS INPUT		37MJH - High 19MJH - Low	37MJH - High 19MJH - Low	37MJH - High 19MJH - Low

REACH FOR THE STARS

4.6 star energy rating 4.6 star energy rating 4.6 star energy rating



GRANGE TECHNICAL SPECIFICATIONS



		GRANGE B/W FREESTANDING	GRANGE INBUILT	GRANGE B/W INBUILT + VICTORIAN	GRANGE DOMAIN	GRANGE SLIMLINE + VICTORIAN	GRANGE F/S & PEDESTAL
HEATING CAPACITY UP TO SQUARES SQUARE METRES*		20 200	20 200	20 200	20 200	20 200	20 200
EFFICIENCY RATING		86.5%	86.5%	86.5%	86.5%	86.5%	86.5%
STAR RATING		5.1	5.1	5.1	5.1	5.1	5.1
CAST IRON FASCIA DIMENSION (mm) & MODEL				990 x 1130 (600)		990 x 1130 (600)	
FIRE BOX	HEIGHT (mm) WIDTH (mm) DEPTH (mm)	N/A	595 700 245	595 700 245	600 705 430	600 705 430	640 775 430
OVERALL DIMENSIONS	HEIGHT (mm) WIDTH (mm) DEPTH (mm)	770 665 395	740 860 430	680 860 430	680 860 450	680 860 450	1035 775 430
FASCIA DEPTH (MM)		N/A	20	20	40	20	N/A
FLUEING OPTIONS	VERTICAL HORIZONTAL UNDER FLOOR	YES YES YES	YES YES YES	YES YES YES	YES YES YES	YES YES YES	YES YES YES
THERMOSTAT CONTROLLER		STANDARD	STANDARD	STANDARD	STANDARD	STANDARD	STANDARD
HEAT TRANSFER KIT		NO	OPTIONAL	OPTIONAL	OPTIONAL	OPTIONAL	NO
NATURAL GAS & LPG		YES	YES	YES	YES	YES	YES
DESPATCH WEIGHT (KG)		82	84	84	90	90	84
GAS INPUT		37MJH - High 19MJH - Low	37MJH - High 19MJH - Low	37MJH - High 19MJH - Low	37MJH - High 19MJH - Low	37MJH - High 19MJH - Low	37MJH - High 19MJH - Low

Tested and approved

Tested and approved to the most stringent quality standards for safety and efficiency. AGA approved. Certificate No. 7048G.

Coonara Warranty

All current Coonara gas heaters are warranted to be free from defects in material and workmanship under normal use and service. The warranty of the actual firebox and heat exchanger is 5 years – to the initial purchaser. All other components (except accidental breakage of door glass) are warranted for a period of 24 months. Coonara gas log fires are designed and tested for use with Coonara manufactured flue kits. For the full warranty statement, refer to the Shamic Sheetmetal (Aust) P/L website (www.shamic.com), the product installation manual, or your Coonara dealer. Shamic goods come with guarantees that cannot be excluded under Australian Consumer Law. The purchaser is entitled to a replacement or a refund for a major failure and compensation for any reasonably foreseeable loss or damage. The purchaser is also entitled to have the goods repaired or replaced if the goods fail to be of acceptable quality and the failure does not amount to a major failure. All heaters pictured in this brochure are operating on Natural Gas. Flame patterns are different on LPG.

Note: All Coonara heaters must be installed by our authorised installer to be covered by our warranty statement.

Your Legendary Coonara dealer is:

***IMPORTANT: Heating areas provided are based on open plan living areas and 2.4 metre ceiling height. Note: Lack of insulation, large window areas and cathedral ceilings reduce heating effectiveness.**

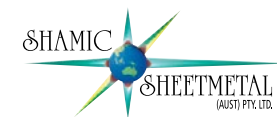

14-18 Research Dve,
Croydon Sth. 3136
Tel: (03) 9737 5300
Fax: (03) 9761 6455
A.B.N. 61 007 251 569
www.shamic.com

All of the information contained in this brochure was correct at the time of printing, March 2018. However, the manufacturer reserves the right to make changes to design and specification without notice. You can confirm current designs, specifications, optional extras and financial details by consulting your nearest authorised Coonara dealer.

Please note: Due to the nature of the printing process, colours may vary from those shown in this catalogue. Ask your dealer to show you a colour sample.