



The logo for nectre, featuring a stylized orange flame icon above the word "nectre" in a lowercase, sans-serif font.

Form 2

OPERATING INSTRUCTIONS

PREMIUM PORTRAIT WOOD HEATER



NECTRE FORM 2 (NF2-22)



Glen Dimplex Australia proudly supports the activities of Landcare Australia through its membership of the AHHA.

VERSION 1.0

TABLE OF CONTENTS

USER INSTRUCTIONS

1.	Introduction	2
1.1.	Air Controls	2
1.2.	Door Handle	2
1.3.	Wood Storage Compartment	3
2.	Using Appliance for the First Time	3
3.	Recommended Fuels	3
4.	Lighting the Fire	3
5.	Running the Appliance	3
5.1.	High Heat Output	3
5.2.	Low Heat Output	4
5.3.	Reload with More Wood	4
6.	Burning Tips	4
6.1.	Fuel Quality	4
6.2.	Flue Draught	4
7.	Ash Removal	5
8.	Flue/Chimney Fire	5
9.	Cleaning Paintwork and Glass	5
10.	Cleaning the Flue	5
11.	Troubleshooting Tips	6
11.1.	Glass in Door Blackening	6
11.2.	Trouble Starting the Fire	6
11.3.	Burning Too Quickly	6
11.4.	Glass Cracking	6

MAINTENANCE AND SERVICING

1.	Replacement of Vermiculite	7
2.	Replacement of Baffle	7
3.	Fitting a New Door Seal	8
4.	Fitting New Door Glass	8
5.	Adjusting Door Latch	9
6.	Replacement Spare Parts List	10
7.	Warranty	11

USER INSTRUCTIONS

1. INTRODUCTION

Before use of this appliance please read these instructions fully.

WARNING: ANY MODIFICATION OF THE APPLIANCE THAT HAS NOT BEEN APPROVED IN WRITING BY THE TESTING AUTHORITY IS CONSIDERED AS BREACHING AS/NZS 4013.

WARNING: DO NOT USE FLAMMABLE LIQUIDS OR AEROSOLS TO START OR REKINDLE THE FIRE.

WARNING: DO NOT USE FLAMMABLE LIQUIDS OR AEROSOLS IN THE VICINITY OF THIS APPLIANCE WHEN IT IS OPERATING.

WARNING: DO NOT STORE FUEL WITHIN HEATER INSTALLATION CLEARANCES.

WARNING: WHEN OPERATING THIS APPLIANCE AS AN OPEN FIRE USE A FIRE SCREEN.

WARNING: OPEN AIR CONTROL BEFORE OPENING DOOR.

WARNING: DO NOT BURN WOOD THAT IS PAINTED; OR IS COATED WITH PLASTIC; OR HAS BEEN TREATED WITH ANY CHEMICAL.

CAUTION: THIS APPLIANCE SHOULD NOT BE OPERATED WITH CRACKED GLASS.

CAUTION: THIS APPLIANCE SHOULD BE MAINTAINED AND OPERATED AT ALL TIMES IN ACCORDANCE WITH THESE INSTRUCTIONS.

The appliance or flue system should not be modified in any way without the written approval of the manufacturer.

Extraction fans or rangehoods placed in the same room or space can cause appliance to emit smoke into the room unless outside air kit is installed.

1.1. AIR CONTROLS

The Nectre Form 2 features a single air control system. This single control modulates the amount of oxygen that enters the firebox at two points - at the top of the door glass, as well as directly at the base of the fire controlling the rate of combustion of the wood. In addition, oxygen is drawn into the upper firebox through the burn channel, where combustion of the gases occurs.

The air control is operated by sliding the round stainless steel tab located on the bottom left of the door. Sliding the tab all the way clockwise offers maximum burn rate, while sliding all the way counter-clockwise offers minimum burn rate. See below:

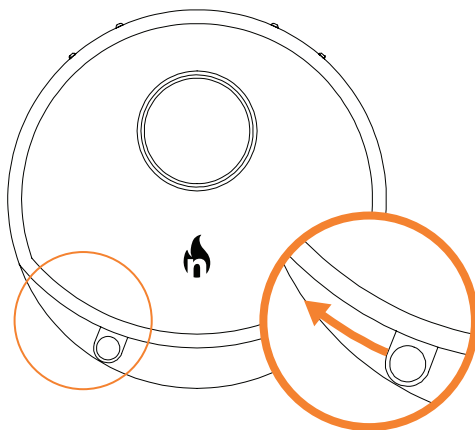

1.2. DOOR HANDLE

Warning: door handle may get hot if appliance has been left in High burn setting for an extended period of time, in which case use a protective glove or equivalent to open.

Open the air slide before opening the door to eliminate the chance of backdraft and/or smoke entering the room.

1.3. WOOD STORAGE COMPARTMENT

Warning: the Nectre Form 2 features a storage area for a small amount of firewood. Do not overload this compartment - ensure that there is at least a 5mm gap to the ceiling of the unit, and no combustible fuel forward of the storage area.

2. USING APPLIANCE FOR THE FIRST TIME

The first few times the appliance is lit, it will give off some odorous fumes. This is caused by the paint curing.

Do not touch the paint work while it is curing otherwise it can leave a permanent mark on the appliance.

Once the paint has cured it will not re-occur.

Keep the room well ventilated until fumes have cleared.

3. RECOMMENDED FUELS

Burn only seasoned hardwood timber with a moisture content of less than 20%. Newly cut wood should be allowed to dry/season for 12 to 18 months before use.

Wood should be stored in an environment protected from the weather to minimize any potential moisture content.

For best results, wood should not exceed 350mm length and 150mm diameter. Any larger, and the appliance will not operate at its optimum. It is better to burn several smaller pieces of wood than one large single piece.

Poor quality timber:

- Causes low combustion efficiency
- Produces poor emissions (smoky)
- Results in additional buildup of creosote (soot) in the flue which will then require regular cleaning and may result in a flue fire.

Do not burn painted, impregnated/treated wood, manufactured board products or pallet wood.

4. LIGHTING THE FIRE

1. Place firelighters and/or paper and dry kindling wood in the base of the firebox.
2. Fully open the air control located on the bottom left of the door by sliding it all the way clockwise.
3. Light the paper or firelighters.
4. If necessary, leave the door slightly open as the fire establishes and the glass warms to avoid the buildup of condensation.
5. Once the fire has taken hold, add larger pieces of wood. Too many logs may smother the fire.
6. Close the door.

Do not leave fire unattended while the door is open.

5. RUNNING THE APPLIANCE

The heat output of Form 2 is controlled by the air control.

5.1. HIGH HEAT OUTPUT

After establishing the fire and loading it with larger pieces of wood, leave it running with the air control fully open (slid all the way clockwise).

This setting will generate maximum heat output.

Running the appliance with the door open will not produce maximum heating in the room as it will draw a lot of already warmed air out of the room.

Do not overload firebox with fuel.

Note that this setting is not the most energy efficient as some heat is lost up the flue instead of being transferred into the room. However, once the fire is established, particulate emissions will be very low in this setting.

5.2. LOW HEAT OUTPUT

The heat output of the appliance can be reduced by closing the air control (sliding all the way counter-clockwise) which will restrict the oxygen supplied to the fire and slow down the rate at which the wood burns.

This setting provides the best energy efficiency as the wood burns for longer. However, if not operated correctly it may worsen emissions.

Prior to closing the air control, ensure that the fire is burning briskly. This may require opening the air control fully for 5-10mins before shutting down.

For the optimum between clean burning and getting the best in efficiency, slide the air control to the middle position.

The air control can be adjusted to any position depending on desired heat output versus burn time.

5.3. RELOAD WITH MORE WOOD

1. Open air control before opening door.
2. Rake / break up any existing coals.
3. Load the wood with the length orientated front to back.
4. Better results will be achieved by loading several smaller pieces of wood rather than one large piece.
5. Close door with air control fully open, and leave for minimum of 10 minutes to allow the fresh wood to catch.
6. After 10 or more minutes, the air control can be adjusted to the desired heat output setting.

6. BURNING TIPS

6.1. FUEL QUALITY

Use wood with a moisture content of less than 20%. Logs should not feel moist/damp, or have moss/fungal growths.

Symptoms related to wet wood:

- Difficulty starting and keeping a fire burning well.
- Smoke and only small flames.
- Dirty glass and/or fire bricks.
- Rapid creosote build-up in the flue/chimney.
- Low heat output.
- Short burn times, and blue/grey smoke from the flue/chimney outlet.

Run appliance at high heat output for a short period each day to avoid large build-up of tars and creosote within the appliance and flue.

6.2. FLUE DRAUGHT

The flue has two main functions:

1. To safely remove smoke, gases and fumes from the appliance.
2. To provide a sufficient amount of draught (suction) in the appliance to ensure the fire keeps burning.

Draught is caused by the rising hot air in the flue when the fire has been lit. The position, height and size of the flue can affect the performance of the flue draught. Refer to installation guide for details on flue installation.

Factors affecting the flue draught include:

- Insufficient flue height
- Trees or other buildings nearby causing turbulence
- High and gusty winds
- Outside temperature and weather conditions
- Blocked flue

For advice on the correction of persistent flue problems consult your supplier/installer for more detail.

7. ASH REMOVAL

Depending on the type of wood burnt and frequency, the ashes will need removing every 2 to 6 weeks.

Retaining at least 10mm of ash helps protect the firebox base, and can make it easier to start the fire next time.

Excess ashes should be removed when necessary, placed in a non-combustible container with a tightly fitting lid and moved outdoors immediately to a location clear of combustible materials.

8. FLUE/CHIMNEY FIRE

If a flue/chimney fire occurs:

- Shut air control fully to smother the fire
- Do not use the appliance after a flue fire until an accredited installer has assessed the cause and any resultant damage.

9. CLEANING PAINTWORK AND GLASS

The appliance, when cool, can be cleaned with a damp cloth.

Over the years, the black paint will fade and can be touched up with Stove Bright metallic black paint.

To clean the glass, we recommend using a household window cleaner or general purpose cleaner with a soft cloth. Do not use abrasive cleaner or scourer pads.

10. CLEANING THE FLUE

Check inside of flue prior to each season for any build-up of creosote (wood tar). To do this:

1. First remove the baffle (refer to "2. Replacement of Baffle" under Maintenance & Servicing section).
2. Using a small mirror and torch hold the mirror on an angle below the flue with the torch shining at it and look for black creosote build-up. A fine black powdery layer is normal, but if built up layers of creosote can be seen, then the flue needs cleaning.
3. Refit the baffle if no cleaning is required.

To clean the flue:

1. A flue cleaning brush can be purchased from most wood heater retail outlets or large hardware stores.
2. The objective is to pull the brush down through the flue.
3. With the baffle removed, tie a rope to one end of the brush, and drop the rope from the top (outside on top of the roof) down the flue.
4. Grab the end of the rope inside the firebox and pull the brush through.
5. Check the inside of the flue with the mirror and torch. Repeat if necessary.
6. Once clean, remove any excess creosote from the firebox and replace the baffle.

Check flue integrity by checking that the 900mm flue sections have not separated at the joins.

Alternatively, get a flue cleaning service to do the job for you (it's a dirty job).

11. TROUBLESHOOTING TIPS

11.1. GLASS IN DOOR BLACKENING

This can have several possible causes:

- Burning unseasoned wood — if the wood is too wet, it will cause the glass to blacken.
- Appliance operated at low temperature — after an overnight burn where the air slide control has been fully closed, the glass may have blackened. When the fire is re-stoked and burning on the high heat setting, the blackened glass should self-clean.
- Problems with the flue — insufficient flue draught can cause the glass to blacken. If the flue is too short, not properly insulated, or in a position that results in a downdraught, then there will be insufficient flue draught. Contact the installer should this happen.

11.2. TROUBLE STARTING THE FIRE

If all ash has been removed from the firebox, it can upset the supply of air to the base of the fire. When cleaning out the firebox, retaining some ash can make it easier to start the fire next time.

11.3. BURNING TOO QUICKLY

If you find that the heater is burning through wood too quickly, it could be due to one or a combination of the below factors:

1. Latch needs adjustment (refer to "5. Adjusting Door Latch" on page 9)
2. Door seal needs replacing (refer to "3. Fitting a New Door Seal" on page 8)
3. Baffle needs replacing (refer to "2. Replacement of Baffle" on page 7)

11.4. GLASS CRACKING

Do not over tighten the screws on the stainless steel strips that hold the door glass in place. Otherwise, expansion of the cast iron door may cause the glass to crack.

MAINTENANCE AND SERVICING

1. REPLACEMENT OF VERMICULITE

Vermiculite is a naturally occurring aluminium-magnesium silicate material that is non-toxic and environmentally friendly. The purpose of the vermiculite bricks in the appliance is to promote a higher internal temperature resulting in a longer burn time and greater efficiency. Over time the vermiculite may become cracked and crumble away. If so, then it should be replaced soon after.

To replace the vermiculite lining:

1. Move any ash away from the base of the bricks.
2. Remove the brick retainer and remove the bricks.

Replace the vermiculite bricks into the firebox as shown in the diagram.

1. Two large bricks with one angled edge - one on either side of the firebox. Place angled edge towards the back of the firebox.
2. Two tall and skinny bricks with two angled edges - one on either corner of the firebox. Ensure angled cut meets up neatly with side bricks.
3. One large brick at the rear.

Once bricks are in, fit the retainer over the top to hold them in place.

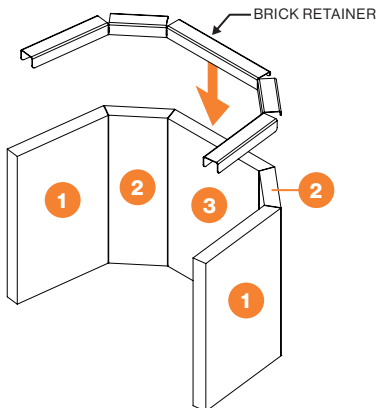

2. REPLACEMENT OF BAFFLE

The 25mm thick vermiculite baffle helps to retain heat in the firebox by lengthening the path of the flames so that they do not go straight up the flue.

Over time, the baffle may begin to deteriorate a little due to the excessive heat. This will not affect the way the fire burns.

Eventually the baffle may wear out (5+ years) and if so will need replacement. To replace the baffle:

1. Shift the baffle to the right of the heater, lifting the baffle up on the right side.
2. With the right side of the baffle raised above the right baffle rail, angle the left side of the baffle downwards to clear the left baffle rail. Refer to diagram below.
3. Remove baffle from heater. Repeat steps 1 to 3 in reverse to install new baffle.

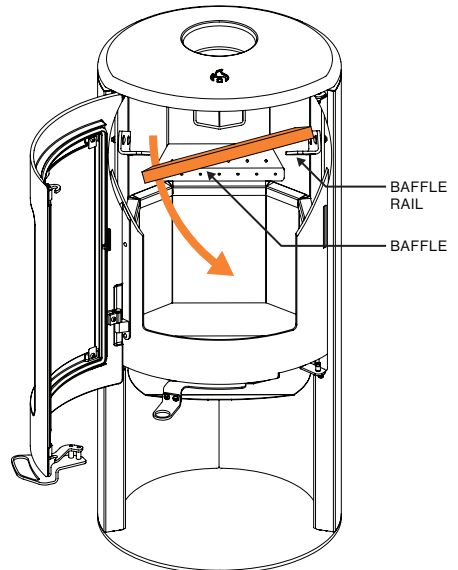

3. FITTING A NEW DOOR SEAL

Remove the door from the heater and lay it horizontally on a work-bench.

1. Remove any old seal from the door.
2. Clean out the groove in the door that held the seal using a flat-end screw driver or equivalent.
3. Run a thin bead of clear roof and gutter silicone along the groove.
4. Starting at one end, press the new door seal rope into the groove on the door.
5. Refit the door and close.

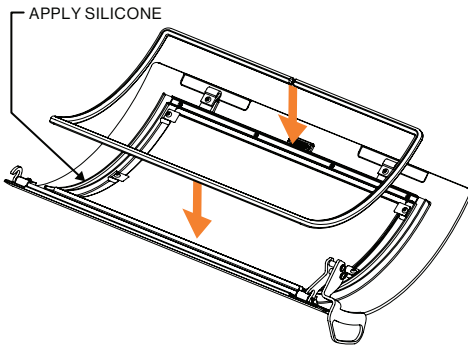

4. FITTING NEW DOOR GLASS

To replace the door glass, remove the door from the heater and lay it horizontally on a work-bench.

1. Six small stainless steel tabs hold the glass in place. Remove the screws from the stainless steel strips with a 4mm hex key.

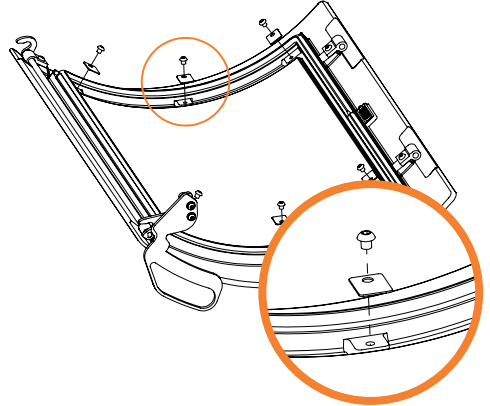

2. Take out the glass, and the flat grey glass seal rope beneath it. The glass replacement kit will come with replacement glass seal.

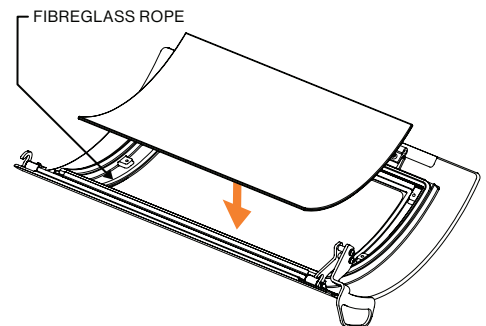

3. Position the new glass on top of the replaced glass seal and re-fit the stainless steel tabs and screws.
4. Hand-tighten the screws until firm. Take extra care not to over-tighten the screws, otherwise the glass will crack when the heater gets hot and the door expands.
5. Dispose of the old glass in a responsible manner, and re-fit the door to the heater.

5. ADJUSTING DOOR LATCH

Over time, the door seal can become compressed, resulting in a less than adequate seal between the door and the front face of the firebox. For example, if the wood burns unusually fast even with the air control set to low, it may mean that there is an air leak around the door.

In this situation, the door seal does not necessarily need replacing — adjustment of the door latch can tighten the seal.

Form 2 has a twin hook latch that fastens at two points highlighted in the diagram below. These latch points can be adjusted forwards and backwards as needed.

To adjust the door latch:

1. Using 8mm spanner, hold the M5 hex nut tight.
2. Using 3mm hex key, loosen the M5 shoulder screw. When loose, the latch point will be able to freely slide forward and backward.
3. Slide the latch point inwards approximately 1mm and retighten the shoulder screw.
4. Do this on both latch points.
5. Close the door and test the tightness of the latch. If too tight or not tight enough, readjust until adequate latching pressure is achieved.

If the door is still not latching adequately, replace door seal.

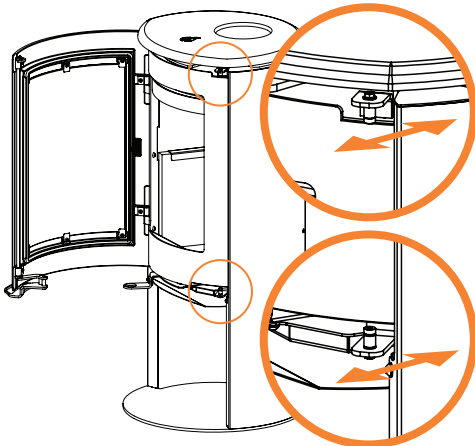

6. REPLACEMENT SPARE PARTS LIST

PART NO.	PART	DETAIL
N900-373	Vermiculite set	2 @ 280 x 189 x 25mm with one angled edge
		2 @ 280 x 110 x 25mm with two angled edges
		1 @ 280 x 217 x 25mm with two angled edges
N111-082	Brick retainer	Stainless steel
N111-057	Baffle	423 x 285 x 25mm tapered vermiculite
N111-041	Door seal	1810mm x 14mm round fibreglass rope
N111-096	Glass replacement kit	1 x glass (5mm pyro ceramic curved)
		1 x glass seal (1630 x 8 x 3mm flat adhesive backed fibreglass rope)
N900-423	Latch kit	2 x Shoulder screw M5 X 12mm
		2 x Latch bushing OD10mm X 11mm
		2 x M5 hex flange nut
		2 x M5 flat washer
N900-424	Outside air kit	1 x Outside vent termination
		1 x 1 m length of 75mm diameter semi-rigid duct
		2 x hose clamp

7. WARRANTY

Glen Dimplex Australia Pty. Ltd. warrants this stove to be able to operate under normal use and service and within 10 years from the date of the original purchase on the terms herein shall repair or replace without cost to the original customer any part thereof which shall be returned to our factory, transportation charges prepaid and which our inspection shows would prevent operation.

This warranty does not apply to firebricks, brick retainer, baffle, door seal, glass, nor discolouration of the surface or tarnishing of chrome fittings all of which require normal service to maintain them.

Under the terms of this warranty, Glen Dimplex Australia Pty. Ltd. assumes no responsibility for the labour costs involved in removing or replacing the stove. Nor shall Glen Dimplex Australia Pty. Ltd. be liable for any injury, loss, or damage (direct, indirect or consequential) arising out of the use or inability to use the product, or its removal and replacement. All other stove warranties, expressed or implied are excluded to the extent possible to law. Any claims against Glen Dimplex Australia Pty. Ltd. must be brought within Australian Jurisdiction.

Electric fans and any remote sender or transmitter are warranted against failure to operate for a period of 1 (one) year from original purchase date.

The Retailer does not have the authority to alter this warranty.



Glen Dimplex Australia Pty Ltd

8 Lakeview Drive,
Scoresby Victoria 3179
Australia

T: 1300 556 816 | F: 1800 058 900

General and Sales Enquiries: flame@glendimplex.com.au

Technical Service: service@glendimplex.com.au

www.glendimplex.com.au