



Arrow Series 2017

Arrow 2000



Arrow 2400



INSTALLATION & OPERATING INSTRUCTIONS

Serial Number of Heater: _____ Model: _____

ARROW WOODHEATERS ARE AUSTRALIAN OWNED AND
MANUFACTURED BY

SHAMIC SHEETMETAL (AUST.) PTY. LTD.

PO BOX 8, KILSYTH, VIC. 3136
PH: 03 9737 5300 FAX: 03 9761 6455
<https://shamic.com>

SAVE THESE INSTRUCTIONS

INSTALLATION AND OPERATION INSTRUCTIONS

Have your heater installed by a registered or licensed installer, and advise your insurers for inclusion in your household contents policy.

In some states the installer is required to issue a certificate of compliance on the installation; - ensure you obtain this if applicable!

The heater should be checked for scratches/dents prior to installation. Once the heater has been installed scratches or dents may not be covered by warranty.

ARROW Woodheaters should not be modified in any way!

Do not operate the heater with the door open for extended periods.

Always operate with door closed except when lighting or refuelling, and maintain all seals in good condition!

Keep children away from the heater when operating!

WARNING: When in operation heater door glass is extremely hot!

WARNING: ARROW WOODHEATERS AND DEALER SPECIFIED FLUES SHALL BE INSTALLED IN ACCORDANCE WITH THE AUSTRALIAN STANDARD AS 2918 AND THE APPROPRIATE REQUIREMENTS OF THE LOCAL BUILDING REGULATORY AUTHORITY.

WARNING: DO NOT USE FLAMMABLE LIQUIDS SUCH AS PETROL, KEROSENE, OR ENGINE OIL TO START OR REKINDLE THE FIRE!

WARNING: "BURN ONLY HARDWOOD"

CAUTION: MIXING OF APPLIANCE OR FLUE SYSTEM COMPONENTS FROM DIFFERENT SOURCES OR MODIFYING THE DIMENSIONAL SPECIFICATIONS OF COMPONENTS MAY RESULT IN HAZARDOUS CONDITIONS. WHERE SUCH ACTION IS CONSIDERED, THE MANUFACTURER SHOULD BE CONSULTED IN THE FIRST INSTANCE!

CAUTION: THE USE OF SOME TYPES OF PRESERVATIVE TREATED WOOD AS FUEL CAN BE HAZARDOUS (for example: treated radiata pine).

CAUTION: DO NOT STORE FUEL WITHIN THE HEATER INSTALLATION CLEARANCES OR WITHIN THE SPACE REQUIRED FOR FUEL CHARGING OR ASH REMOVAL!

CAUTION: OPEN AIR SLIDE AND TURN FAN OFF BEFORE OPENING DOOR!

DISCLAIMER

The information supplied by this company is our interpretation of AS 2918 and we do not accept responsibility for any errors or omissions.

All **ARROW** Woodheaters have been tested in accordance with and comply to AS 4013.

Please read and thoroughly understand these instructions prior to operating this appliance!
Please store these instructions in a safe place for future reference.

INSTALLATION INSTRUCTIONS (FREESTANDING MODELS ONLY)

Select the position of your heater carefully, taking into consideration all combustible materials in the roof; eg. ceiling joists, roof trusses, etc.

Determine flue location through the ceiling:

Position the hearth correctly (see below), then place the heater on the hearth so that the flue spigot on the heater is correctly aligned with the flue location from the ceiling.

Flue Kit requirements

This heater has been tested and approved to AS 2918 using a standard, default triple skin Flue Kit. The Arrow 2400 default kit incorporates an additional 180° x 900mm stainless steel flue shield positioned directly above the appliance between the active flue and deco-mesh casing.

Clearance to combustible surfaces:

(Ensure correct model)

Dimensions in mm

Minimum distance <i>Millimetres</i>	Reference Symbol	ARROW 1800	ARROW 2400	
Standard Installation	A	150	150	
	B	300	380	
Corner Installation	C	130	100	

Hearth material/floor protection, (Bellis Board or other non combustible material) with a minimal thickness of 9mm and a minimum thermal conductivity of 0.1 m²KW per 9mm thickness, must be installed beneath and in front of the heater, as shown below.			
From Front of Heater		300	500
Depth of floor protector		830	1100
Width of floor protector		870	1000

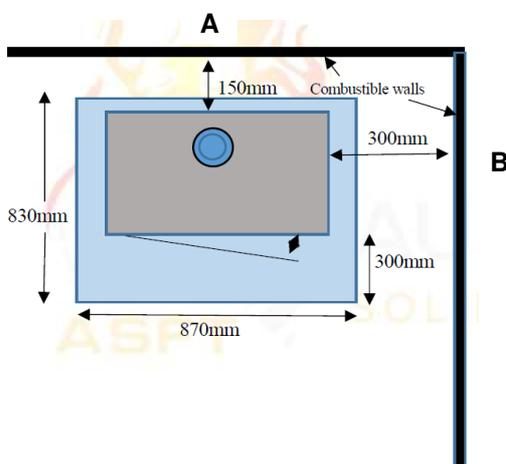

Standard Installation

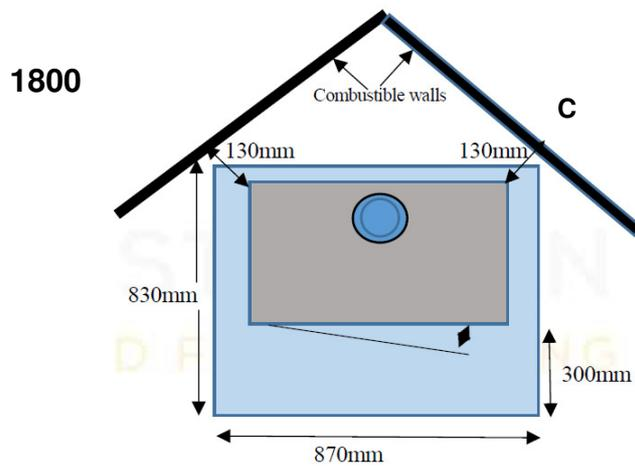

Corner Installation

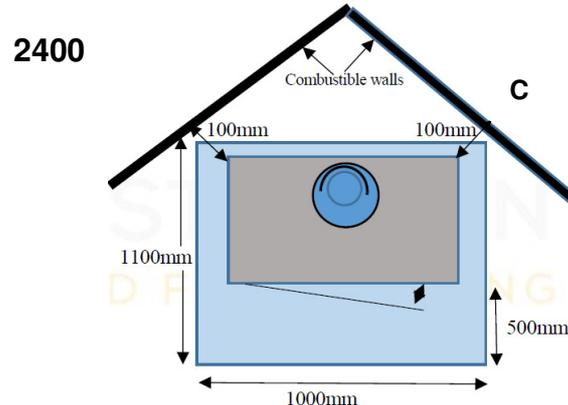
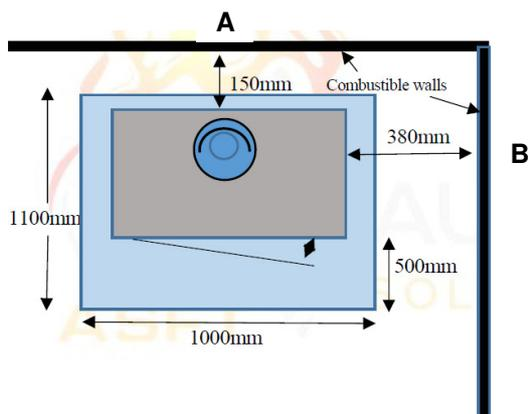

INSTALLATION OF FIRE PLACE INSERT MODELS ONLY

The heater must only be installed in either a sound concrete or masonry fireplace, connected to a chimney, both of which must be inspected for soundness and thoroughly cleaned before the heater is installed. After removing the packaging, slide the heater into the fireplace opening. A standard, default triple skin flue system must be connected to the heater, providing free and effective discharge of combustion by-products outside the building and any enclosed or confined space.

The stainless steel ring (supplied with the heater) must be fitted to the flue spigot of all Inbuilt models for correct location of the flue.

THERMAL CLEARANCE TESTING OF THE ARROW 1600 MKII INSERT SOLID FUEL APPLIANCE

Report

The Arrow 1600 MkII Insert appliance was tested in a simulated fireplace in a manner conforming to joint Australian/New Zealand Standard 2918:2001, Appendix B.

A minimum 340mm deep x 560mm wide x 45mm thick floor protector (Bellis board) should be used under the appliance (clay bricks are acceptable if the fireplace is already lined), a minimum 870mm wide x 450mm deep x 18mm thick floor protector (Bellis board) must be used in front of the appliance base when installing the appliance (see joint AS/NZS 2918:2001 3.3.2). The floor protector should extend 450mm in front of each appliance base and be placed centrally in the 870mm width. The Thermal conductivity of the floor protector is 0.1m².K/W for 9mm thick sheets.

The Arrow 1600 MkII Insert solid fuel appliance installed into a simulated fireplace conforms to the requirements of the joint AS/NZS 2918:2001 Standard, Appendix B.

The appliance and Flue Combination should be installed at the following clearances;

- 500mm from the underside mantle shelf to the top of the appliance hot air outlet, the mantle shelf shall extend no further than 250mm into the room
- Mantle uprights shall be no closer than 15mm from the side of the mantle uprights to the side of the appliance facia and the mantle uprights shall be no thicker than 70mm

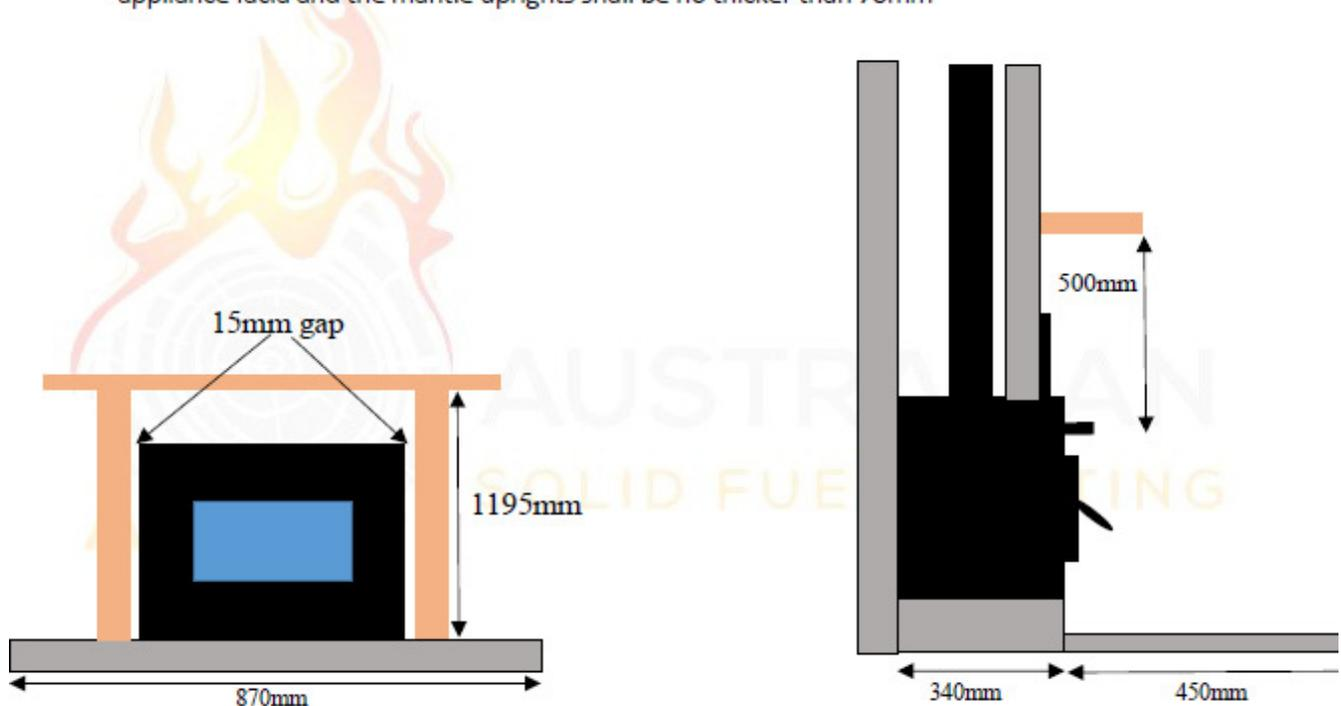

THERMAL CLEARANCE TESTING OF THE ARROW 2000 MKII INSERT SOLID FUEL APPLIANCE

Report

The Arrow 2000 MkII Insert appliance was tested in a simulated fireplace in a manner conforming to joint Australian/New Zealand Standard 2918:2001, Appendix B.

A minimum 400mm deep x 700mm wide x 45mm thick floor protector (Bellis board) should be used under the appliance (clay bricks are acceptable if the fireplace is already lined), a minimum 1000mm wide x 470mm deep x 18mm thick floor protector (Bellis board) must be used in front of the appliance base when installing the appliance (see joint AS/NZS 2918:2001 3.3.2). The floor protector should extend 470mm in front of the appliance base and be placed centrally in the 1000mm width. The Thermal conductivity of the floor protector is 0.1m² K/W for 9mm thick sheets.

The Arrow 2000 MkII Insert solid fuel appliance installed into a simulated fireplace conforms to the requirements of the joint AS/NZS 2918:2001 Standard, Appendix B.

The appliance and Flue Combination should be installed at the following clearances;

- 550mm from the underside mantle shelf to the top of the appliance hot air outlet, the mantle shelf shall extend no further than 250mm into the room
- Mantle uprights shall be no closer than 20mm from the side of the mantle uprights to the side of the appliance facia and the mantle uprights shall be no thicker than 70mm

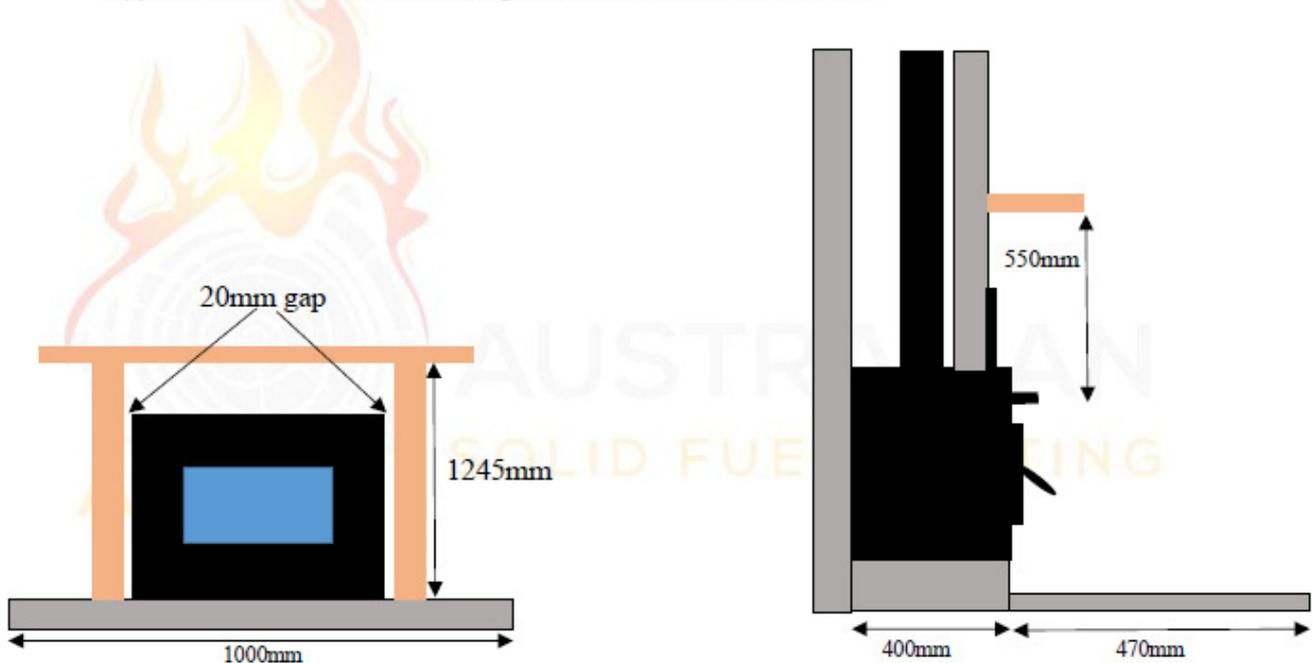

Firebox Internal Set Up

Step 1. Install the top baffle plate, place both hands underneath the plate lift either the right or left hand side of the plate up so it is on an angle. Lift up over the locating tab on the side of the firebox then lift up the other side and push the plate to the back of the firebox.

Step 2. Install the secondary air tube. Refer Drawing page 7

Step 3. Install cast iron grates

Step 4. Install the rear and side liners. Put the rear liner or liners into the back of the firebox then put in the side liners in to hold the rear liner or liners in place.

Operating Information

Fuel

Ignition: A supply of newspapers or firelighters.

Kindling: 10 mm – 20 mm diameter light, split, pieces of wood.

Start up wood: 30 mm – 75 mm diameter medium size, split pieces of wood.

BURN ONLY HARDWOOD

Starting a fire

Fully open the air inlet by sliding the control arm to the left and then open the firebox door. Lift the door handle upward and open the door slowly.

To build a fire, place crumpled 'balls' of newspaper or place in the firebox. Build a cone or tepee of kindling over the bed of newspaper and ignite. When properly alight, close and latch the door.

When the kindling is well alight add some start up wood, which will prepare the fire to take larger sized firewood. Close the door securely. Switch on the fan after the firebox has heated up. (This could take up to 30 minutes).

Prior to opening the door and loading additional fuel make sure you have given the flue enough time to get hot otherwise smoke and flames could exit the door opening.

Loading

When the start up wood is well alight, add a load of firewood.

Your **ARROW** heater will burn any diameter logs, which fit in the firebox.

Large logs will take longer to ignite but will burn longer.

Once these logs are alight, adjust the air control to desired level.

As well as keeping recommended firewood sizes in mind, the way you load the fuel will affect the operating characteristics of your **ARROW** heater. Always ensure adequate air is provided for combustion and, to reduce creosote, a smaller intense fire is preferable to a large smouldering one.

If a large log is placed across the width of the firebox, more often than not the wood will smoulder rather than burn effectively. This is because the primary burn air enters the **ARROW** firebox above the door opening and travels down the door glass effectively 'washing the glass' (i.e. minimising carbon, soot and creosote deposits), before travelling through the fuel load.

Should primary burn air be restricted in travelling through the fuel load, for example by a large piece of wood lying across the firebox, it follows that the correct combustion process will not take place.

It is better to place 2-3 smaller diameter pieces of wood front to back with a minimum spacing of 20mm as a load and a larger piece or pieces across these.

Note: The fan fitted to the heater should be operating whenever a fire is burning (except on start up). Failure to do so may overheat the unit and void warranty.

Fan operation

ARROW heaters are fitted with a 3-speed fan for efficient distribution of warmth. Always operate the fan when the appliance is in use (except on start up). When operating at low burn, turn down to the lowest setting.

Reloading

The firebox should be loaded to a minimum of 2/3 full, preferably when the fuel has burnt down to a bed of coals. Attempting to reload part way through a burn period risks smoke, coals, or a log rolling from the heater.

Before reloading, it is important to position the air inlet control to high. Taking care, open the door slowly, rake over the coals and load the fuel as recommended. After reloading, close the door securely and leave the air inlet fully open on high until the fuel load is well alight. Then the inlet control can be adjusted to your desired heat output.

Do not throw wood into the firebox

This is an unsafe practice and may dislodge the baffle plate in the heater. It may also cause sparking or dislodge burning wood, which could ignite any combustible materials in the area surrounding the heater (eg. Carpet).

Do not slam the door closed

Wood may be protruding from the firebox and cause the glass to break. It will also diminish the longevity of the door seal.

Preparing for a low (overnight) burn

For an extended low burn, following the reloading procedure outlined previously, ensuring a maximum fuel load is placed into the heater. Remember, the greater the fuel load, the longer the burn. After reloading, close the door and leave the air inlet fully open (high) until the load is alight. The air inlet should then be turned down to a *lower setting.

*The optimum low setting may vary for different reasons, experiment to find the best result!

Self cleaning through high firing

It is perfectly normal for the glass door to experience some blackening after extended periods of low burning. High firing helps burn the door glass clean and minimise soot, carbon and creosote formation on the baffle plate and flue as well. High firing can be done daily during the heating season and morning is usually the best time.

Just start or rebuild the fire with the firebox at least 2/3 full, set the air inlet control to high and let the heater operate in this manner for at least 90 minutes.

Note: Ensure that the heater fan is switched to boost during this procedure, failure to do so may result in excessive deflection of the heater top panel, or damage to the fan / wiring.

Paint curing

To prevent discolouration and flaking of the high temperature paint, do not burn a large fire until the paint on the heater has cured, i.e., do not operate with the air inlet control positioned any higher than mid-point for approximately the first 12 hours of burn time. The curing process may produce a light smoke and odour, which is normal. Should this occur, ventilate the room by opening a window.

Replacement parts

Consult your **ARROW** Dealer regarding any of the normally replaceable components of the heater i.e. handles, baffle plate, cast iron liners, grates, door glass, fans, door seal and bricks.

Maintenance

Paint surfaces

After the curing process has taken place, little maintenance is required other than dusting off with a cotton cloth. Most marks can be buffed out with a cotton cloth without the need for retouching. **NOTE:** Do not use abrasive cleaners or harsh solvents (such as methylated spirits). Should you experience scuffing or scratching, or discolouration due to incomplete curing, the high temperature paint can be touched up and matching spray cans may be purchased from your **ARROW** dealer. To retouch scratches that are down to bare metal, gently sand the surrounding area, with 400 wet and dry sandpaper and respray. Remember, if you retouch your **ARROW**, the surface will require curing and may smoke slightly during this process. This is normal.

CAUTION: DO NOT ATTEMPT TO RESPRAY THE HEATER WHILST IT IS IN OPERATION.

Door glass

It is usual for creosote and/or smoke deposits to form on the door glass, particularly after an extended period of low burn. Creosote deposits are combustible and can be burnt off through high firing. If any deposits remain, they can be cleaned using any non-abrasive household cleaner. Some experienced users also recommend household vinegar or wet newspaper dipped in the fire ash being most effective. If you experience heavy tar like deposits, then inspect your fuel and review your operating methods. **Wet or green wood** will cause heavy creosote deposits on the glass as well as the flue system and will severely restrict your heaters performance.

WARNING: DO NOT OPERATE THE HEATER IF THE DOOR GLASS IS CRACKED.

Door glass seal

Before lighting the first fire of the heating season, test this seal by opening the firebox door and placing a hand either side of the door glass. Your hands should be positioned together with the glass resting between both palms. Gently try to move the glass around within the doorframe, taking care not to use force. If you can move the glass, consult your **ARROW** dealer, as the sealing tape may need replacing.

Baffle Plate and Burn Bar

WARNING: ALLOW THE HEATER TO COOL IF HOT BEFORE ATTEMPTING BAFFLE PLATE REMOVAL.

Burn Bar Assembly 1600 1800 2000 2400

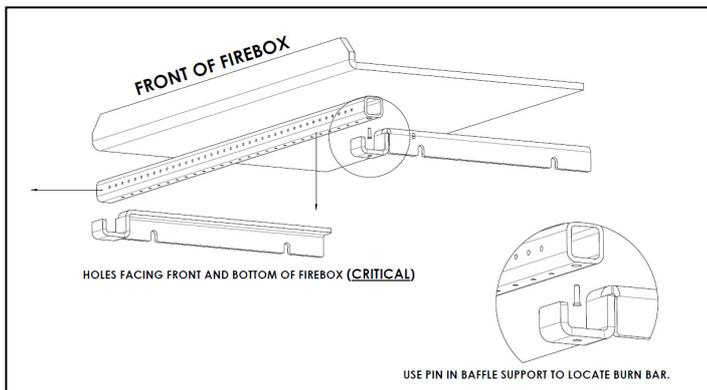

1. Remove secondary air tube where fitted.
2. Lift one side of the baffle upwards; lower other side towards the base clearing the support tabs and pull forward.
3. Reverse procedure to replace baffle.

Steel Baffle Installation 1600 1800 2000 2400

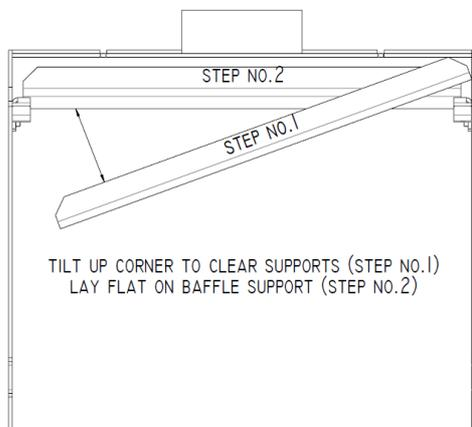

1. When replacing, the folded edge must be closest to the door and facing upwards.
2. The baffle is to be pushed hard up against the rear wall of the firebox.

The baffle plate and burn bar should be removed and inspected annually and flaky deposits shaken or brushed off. The most convenient time to maintain the baffle is when the flue is being cleaned.

Flue System

Under normal conditions, using dry hardwood and employing correct operating procedures, annual flue maintenance should take place prior to the heating season. If your heaters performance deteriorates, or if it smokes excessively after a trouble free period of operation, the cause may be creosote. The creosote may have built up to a level where the gases are restricted from exiting the flue pipe because it is partially blocked. Check your flue for any water leaks that will cause rust in your heater and void the warranty.

<p>CAUTION: THE FLUE PIPE MUST BE KEPT CLEAN AND IN GOOD CONDITION. ALL SOLID FUEL BURNING APPLIANCES NEED TO BE CLEANED FREQUENTLY BECAUSE SOOT, CREOSOTE AND ASH MAY ACCUMULATE. IN THE EVENT OF A SOOT OR CREOSOTE FIRE IN THE FLUE, IMMEDIATELY CLOSE THE AIR INLET CONTROL TO STARVE THE FIRE OF OXYGEN. IT IS RECOMMENDED THAT YOU CALL THE FIRE BRIGADE FOR FUTHER ASSISTANCE AND ADVICE. WHEN THE FIRE IS OUT, HAVE THE FLUE INSPECTED BY A QUALIFIED INSTALLER TO ENSURE THERE HAS NOT BEEN ANY DAMAGE TO THE FLUE SYSTEM.</p>
--

For cleaning the flue, you may purchase a flue brush from your *ARROW* dealer, or you can engage the services of a chimney sweep.

TABLE 1: FIREWOOD SPECIES AND THEIR PROPERTIES

Firewood Species	Forest Type	Heat Avail. Per Unit Volume (%)	Density (Dry Air) lb/ft ³ / Kg/m ³	Splitting	Ignitability	Coals	Sparks	Avail.
Mallee Roots	Mallee	100	N.A	Difficult	Poor	Excellent	Few	Good
Belah, Buloke	Mallee Box-Ironbark	100	70 / 1121	Good	Poor	Excellent	Few	Limited
Grey Box	Box-Ironbark	100	70 / 1121	Difficult	Poor	Excellent	Few	Good
Black Box	Box-Ironbark	97	69 / 1105	Difficult	Poor	Excellent	Few	Limited
Red Ironbark	Box-Ironbark	97	69 / 1105	Difficult	Poor	Excellent	Few	Good
Yellow Box	Box-Ironbark	91	65 / 1041	Difficult	Poor	Excellent	Few	Good
Red Box	Box-Ironbark	91	67 / 1073	Difficult	Poor	Excellent	Few	Good
Yellow Gum	Box-Ironbark	90	60 / 993	Difficult	Poor	Excellent	Few	Good
River Red Gum	River Red Gum	80	56 / 897	Difficult	Poor	Excellent	Moderate	Good
Blue Gum	Foothill	80	61 / 977	Fair	Fair	Good	Few	Good
Red Stringy Bark	Foothill	72	54 / 865	Good	Good	Good	Few	Good
Messmate	Foothill	68	45 / 721	Good	Good	Good	Few	Good
Mountain Ash	Mountain	53	42 / 673	Excellent	Excellent	Fair	Moderate	Good
White Cypress Pine	Box-Ironbark	60	42 / 673	Good	Excellent	Poor	Many	Limited
Radiata Pine	Foothill Plantations	45	32 / 512	Fair	Excellent	Poor	Many	Good

KNOW YOUR WOOD

A piece of dry wood produces an incredible amount of heat when burnt correctly. A piece of dry wood, however is also like a sponge and can absorb up to 70% of its weight in water if exposed to the elements.

The fact that all wood heaters rely on dry fuel to perform at their best, cannot be over-emphasized as it is critical to your heater’s performance. The relevant moisture content (wetness) of wood is indicated in the following table.

Moisture Content	Fuel Suitability
Below 10%	Very dry. Wood burns but less efficiently as some moisture is needed for ideal combustion.
10% - 18%	Ideal. Wood burns efficiently and economically
18% - 25%	Wood will burn, but less efficiently
Above 25 %	Wood too wet to burn efficiently

It is extremely difficult to light, let alone maintain, a fire using wet or green wood. A firebox filled with 20kg, wet or green wood could contain up to 10 litres of water. As a result, the heater would naturally perform very poorly as most of the heat generated would be directed to vaporizing the water. Be aware that if you purchase wood with 50% moisture content, the 50% of the money you paid for the wood, in fact, purchased water.

Ideally, firewood should be organised in the spring and under cover by mid-autumn. If you obtain next year’s wood in spring, it should be open air dried over summer for a minimum of six months. The wood should then be stacked under cover in such a way that air can flow between the pieces. A plastic sheet or tarpaulin is not sufficient as condensation may account for a high moisture content in the wood.

It is important to select firewood that will build a good base or bed of coals. It is actually the coals and not the flames, which form the hottest part of the fire and provide the heat source for your heater.

Dry hardwood has over twice the density of pine, so double the volume of pine is required to provide the same amount of heat. Firewood that has had the bark removed produces less ash. The table above provides a good indication of the properties of various common type of firewood.

How to Make a Warranty Claim

Coonara, ARROW, Arrow and Settler Heaters.

The full Warranty Statement for your heater is contained in the Installation and Operating Instructions booklet that was provided with the product.

1. Check the details of the warranty statement
2. Determine if you think the problem is covered by warranty
3. Ensure that you have proof of purchase
4. Contact the retailer that sold you the heater
5. Advise them of the specific problem
6. Provide the details that your retailer requests to complete a Warranty Claim Form. This must include the heater model, serial number and installation compliance certificate, if applicable in your State.
7. Your retailer will forward your claim to Shamic Sheetmetal (Aust) Pty Ltd, the manufacturer of the above heater brands
8. Shamic will contact you to acknowledge that they have received the claim, if the claim has been accepted and the next steps involved in fixing the problem
9. Parts and/or service is provided
10. Contact your retailer if the problem has not been fixed.

ARROW WOODHEATERS WARRANTY – CONSOLE & INBUILT MODELS

DESIGNATION OF WARRANTOR. This warranty is extended by Shamic Sheetmetal (Aust) Pty. Ltd with respect to ARROW Woodheaters PRODUCT. This ARROW heater is comprised of the heater proper (including components and firebox), fan assembly, speed control switch, electrical components, firebricks, seals and moving parts. Except where specifically excluded from coverage hereunder, this warranty covers all components designed. See exclusions and qualifications below for further information on product coverage.

WARRANTY:

- 1) Shamic Sheetmetal (Aust) Pty. Ltd, warrants the firebox to be free of defects in materials and workmanship of a period of ten (10) years from the date of purchase.
- 2) Shamic Sheetmetal (Aust.) Pty.Ltd., warrants that all other components of the unit to be free of defects in material and workmanship for a period of one (1) year from date of purchase, excluding door glass.
- 3) If this ARROW heater is found to be defective in material or workmanship Shamic will repair or replace such defects in the ARROW heater at Shamic's option in accordance with ARROW's warranty policy during the period on this warranty. If the defect is found not to meet the Consumer Guarantee requirements and constitutes a major failure, the purchaser may be able to choose to repair or replace the defective heater or part or obtain a refund.
- 4) Exclusions and qualifications. This warranty is subject to the following exclusions and qualifications.
 - a) This warranty extends only to the original consumer purchaser, who has purchased the heater from an authorised ARROW dealer.
 - b) This warranty does not apply to, and ARROW assumes no responsibility for any damages that result due to, installation or operation of the heater not in accordance with both the installation and operation instructions furnished with the unit.
 - c) This Warranty does not cover any damage caused by water from any source
 - d) This warranty does not apply to any heater which has been modified or damaged in shipping or by improper handling, improper operation, abuse, misuse, accident or unworkmanlike repairs.
 - e) Shamic Sheetmetal (Aust.) Pty.Ltd. does not warrant the structural performance of the heater when fuel products with abnormal burning characteristics, including but not limited to synthetic logs, coal, wood treated with flammable liquid, logs made from pressed wood, driftwood or any materials containing salt or corrosives, rubbish or garbage are used. Flammable liquid fuels are explosive and should never be used in this product.
 - f) Shamic Sheetmetal (Aust.) Pty.Ltd. Expressly excludes any liability hereunder for defects or damage caused by the installation or of any components not expressly authorised and approved by Shamic. Shamic further assumes no liability for defects or damage caused by any modification not expressly authorised and approved by Shamic. Unauthorised components or modifications could create a fire hazard by altering the safety design of the heater.
 - g) Building Codes. Since building code requirements vary, users should determine in advance whether there are any building code restrictions on the installation or use of the heater. Shamic makes no representation of warranty regarding building code compliance and shall not be responsible for compliance therewith.
 - h) Shamic will only accept claims under this warranty in strict accordance with the conditions set out below.
- 5) Shamic Sheetmetal (Aust.) Pty.Ltd. shall not be liable for any breakages of glass components, transit damage or, where it can be shown that the consumer guarantee obligations as the manufacturer have been met, for any claim by any person for incidental or consequential damages caused by defects in the ARROW heaters. Whether such damage occurs or is discovered before or after replacement or repair, and whether or not such damage is caused by ARROW negligence. Normal wear and tear items such as routine surface maintenance, door ropes, seals and door glass are also excluded from this warranty.
- 6) Shamic goods come with guarantees that cannot be excluded under Australian Consumer Law. The purchaser is entitled to a replacement or a refund for a major failure and compensation for any reasonably foreseeable loss or damage. The purchaser is also entitled to have the goods repaired or replaced if the goods fail to be of acceptable quality and the failure does not amount to a major failure.
- 7) This warranty applies only to units purchased from an authorised dealer and the duration of this implied warranty, including merchantability, applicable to this ARROW heater is limited to the duration of the foregoing warranty.
- 8) Before Shamic Sheetmetal (Aust.) Pty.Ltd. will recognise or accept a claim under this warranty, you must provide proof of purchase. On purchase of the heater, despatch your warranty card to Shamic Sheetmetal (Aust.) Pty.Ltd.
- 9) Your authorised dealer must be notified of any defect in the heater, for investigation of the claim. Your authorised dealer will be able to explain the process of making a warranty claim and any costs associated with returning goods. In the event where a remedy is necessary and the claims under warranty are accepted, the purchaser may be required to return the goods to the authorised dealer for repair, replacement or refund.

DETACH AND RETURN BY MAIL OR EMAIL

SHAMIC SHEETMETAL (AUST) P/L
PO BOX 8 KILSYTH, VIC. 3136
Ph: 03 9737 5300 Fax: 03 9761 64 55
Email: info@shamic.com.au



NAME _____

ADDRESS _____

CITY / STATE / POSTCODE _____

PURCHASED AT (Dealer name & address) _____

DATE PURCHASED _____ MODEL _____ SERIAL NO _____

WHERE DID YOU HEAR ABOUT ARROW WOODHEATERS? RADIO, TELEVISION, NEWSPAPER, DEALER, WEBSITE, OTHER - Please provide details.