



2515 Bypass Rd. Flemingsburg, KY 41041  
606-845-7439

**Instructions for Installation and Care of Yamaha Viking Soft Door Kit**  
YA-VIKING-SDK01

**Notice: Do not smoke inside the cab or expose the enclosure to direct flames. Cab is Flammable.**

1. Be sure to read these instructions thoroughly before opening and installing the Yamaha Viking Soft Door Kit. The installation is best done when the temperature is 70 degrees F. or warmer. The temperature affects the adhesive Velcro, if conditions prevent installing in warmer weather it helps to store the adhesive Velcro at room temperature prior to installation.
2. Carefully open the carton and remove the enclosure on a large flat surface that is clean and free of dirt.
3. Check over the parts included in the carton with the parts list shown below:

	<u>Doors</u>
2" Adhesive Velcro Hook Strips:	16 each-----3"
“ “ “ “	2 each-----6"
“ “ “ “	2 each-----8"
“ “ “ “	2 each-----16"
1" Adhesive Velcro Hook Strips:	2 each-----6"
Snap Studs	7 each (1 extra)

1. If possible, have someone else hold the door in place and mark the location of each Velcro strip sewn along the **top and front** edges of the door. Now take the supplied 3" adhesive Velcro strips and wrap them around the roll cage at the marked locations. Now put the door back onto the vehicle and wrap the double-sided Velcro around the adhesive Velcro as shown in the photo below.



2. The rear edge of the doors has 3 strips of Velcro sewn down the entire length. Starting at the top use the 6", 16" and 8" adhesive strips to attach the door to the roll cage. This attaches to the Velcro sewn down the sides of the rear window. See photos below.



3. The diagrams below show how the double-sided straps and the 3" adhesive Velcro works.

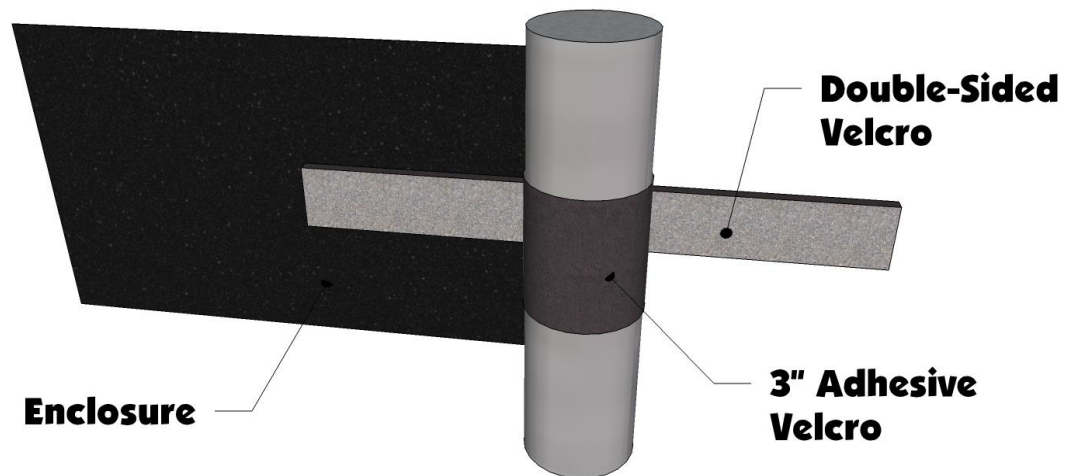

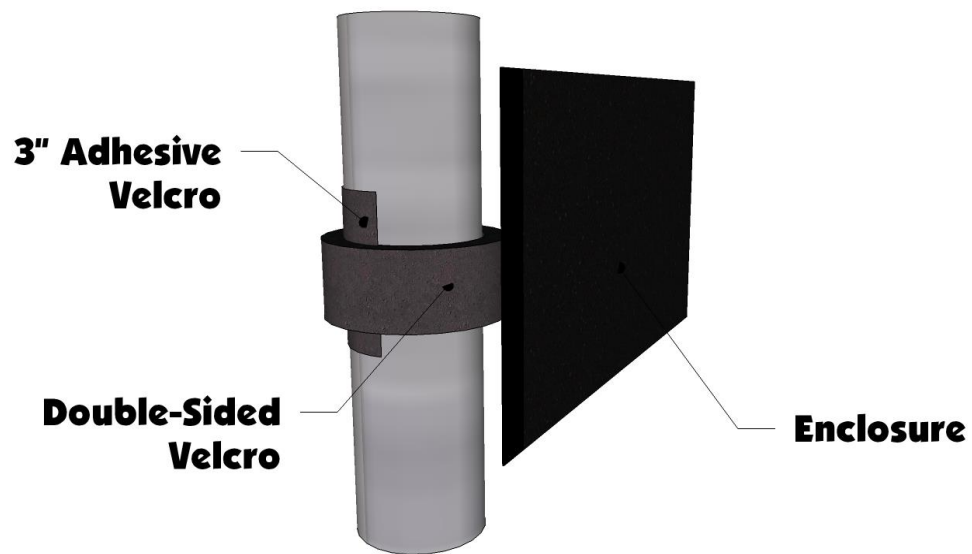

4. The front bottom corner of the door is held in place by a 1" wide 6" long adhesive Velcro strips. The photo below shows the proper placement.



5. Finally, the bottom of the door has three snaps, one on the inside and two on the outside. Best way to put the screw studs in the correct place is to install the screw stud into the snap on the door first. Then pull the door in place and push the point of the screw into

the plastic making sure to leave a good mark. Then pull the snap stud out of the door and screw into the plastic where the mark was left. See photo below.



#### Cleaning and Storage Recommendations:

1. Before removing the Falcon Ridge Cab for storage, make sure it is very clean in order to prevent scratching of the window panels. Clean with a soft rag or sponge using a mild liquid detergent soap and warm water solution. Never rub the windows with a dry cloth or rag! Let the Cab dry thoroughly before attempting to roll for storage.
2. It is important that the Cab be rolled up for storage rather than folding. Folding will cause damage to the windows!!! Carefully roll up the Cab similar to the way it was when it was packed at the factory. On a large, clean and flat surface, fold the doors over the rear panel first, then, interleave the top and windshield on top of the doors. Begin rolling the Cab into a roll approximately 8 inches in diameter. Put the rolled Cab back into the carton for storage at a normal room temperature. It is best not to expose the Cab to either extreme hot or cold temperatures when storing.

## Return Policy

If for any reason you choose to return this product it must be returned within **30 days from date item is received**. You **MUST** package the product exactly **as it was originally packaged from the factory to get a full refund for the product!**

The vinyl windows should never be folded when packaging in the box or for storage purposes. Lay all the windows on top of each other with the canvas folded in between and the paper (if available) on both sides of the windows.

**All returned products will be inspected upon arrival at the production facility and must be in unused, factory new condition to receive refund - a 25% restocking fee will apply.**

If ordered from Falcon Ridge please call at 606-845-7439 to gain a return authorization number, use our preferred shipping carrier (UPS) to return the item (unless the item is defective, you are responsible for paying the shipping to return the item.) **Any returns submitted to Falcon Ridge without a return authorization number will be charged a 20% restocking fee.** If ordered from one of Falcon Ridge's many distributors, you must first call them and see what their return policy is. Once your item reaches our production facility, our customer satisfaction team will inspect your item to ensure unused, factory new condition. **NOTE: All windshields must be returned with the original protective film intact and not removed. Do NOT REMOVE if you have any intentions of returning the item. Refund/ replacement of a windshield will only be processed on items with original protective film or if the windshield is defective.**

Items must be properly packaged in the original shipping carton to protect them during transit and ensure your returned item arrives back factory fresh, and in new resalable condition (**any returned items that have been used, altered or damaged in any way will not be subject for a refund.**) All contents including instruction manuals, accessories, hardware, Velcro, etc. must be included in your return shipment. Only items in OEM factory new condition will be approved. Once returned items are received, credit will be issued to the original credit card/ payment method used for the purchase. Outbound shipping and return shipping cost will not be refunded. Please allow 4 to 6 weeks for your refund to be processed.

# Warranty

To The Owner of this Product:

Thank you for purchasing one of Falcon Ridge's Cab Enclosures, Tops &/or Windshields!  
Below are the terms under which your product is covered under our manufacturer's warranty.

30 Day Warranty which includes and is not limited to replacing the enclosure, tops and/or windshield due to defect of the product. Please refer to the return policy in this case for more information.

1 Year Warranty includes any defect in material or workmanship within this time frame we will gladly correct the problem or replace the enclosure, tops &/or windshield. Upon submitting for the correction or replacement we will need to receive pictures of the defect in material or workmanship along with the receipt from the date of purchase.

Thank you,

Falcon Ridge