

Over Armour Offroad

2515 Bypass Rd. Flemingsburg, KY 41041
606-845-7439

Instructions for Installation and Care of
2009-2010 Polaris Ranger
Full Cab with Folding Lexan Windshield
PO-10RANGER-FC03

Notice: Do not smoke inside the cab or expose the enclosure to direct flames. Cab is Flammable.

1. Be sure to read these instructions thoroughly before opening and installing the cab enclosure. The installation is best done when the temperature is 70 degrees F. or warmer. The temperature affects the adhesive Velcro, if conditions prevent installing in warmer weather it helps to store the adhesive Velcro at room temperature prior to installation.
2. Carefully open the carton and remove the enclosure on a large flat surface that is clean and free of dirt.
3. Check over the parts included in the carton with the parts list shown below:

Adhesive Velcro Hook Strips:

“	“	“	“	<u>Soft Doors</u>
“	“	“	“	18 each-----3"
				2 each-----38"
Snap Screw Studs				14 each (2 extra)

Adhesive Velcro Hook Strips:

“	“	“	“	<u>Rear Window</u>
“	“	“	“	8 each-----3"
“	“	“	“	1 each-----30"
“	“	“	“	1 each-----55"

	<u>Top Cap</u>
30” Webbing Straps w/ Grommet	2 each
45” Webbing Straps w/ Loop	2 each

The cab for your Ranger is made up of 5 different components that work together to enclose your vehicle. Install the cab in the following order.

- 1) Soft Doors
- 2) Rear Window
- 3) Poly Windshield
- 4) Top Cap

Soft Doors

1. Begin by holding the door up to the frame and attach it using the double-sided Velcro strips sewn perpendicular to the edge of the door. At each of the double-sided strips take one of the 3" adhesive Velcro strips and adhere it to the inside of the frame. Then wrap the double-sided strip around it so that the adhesive strip holds it firmly in place. the following diagrams shows how it should look.

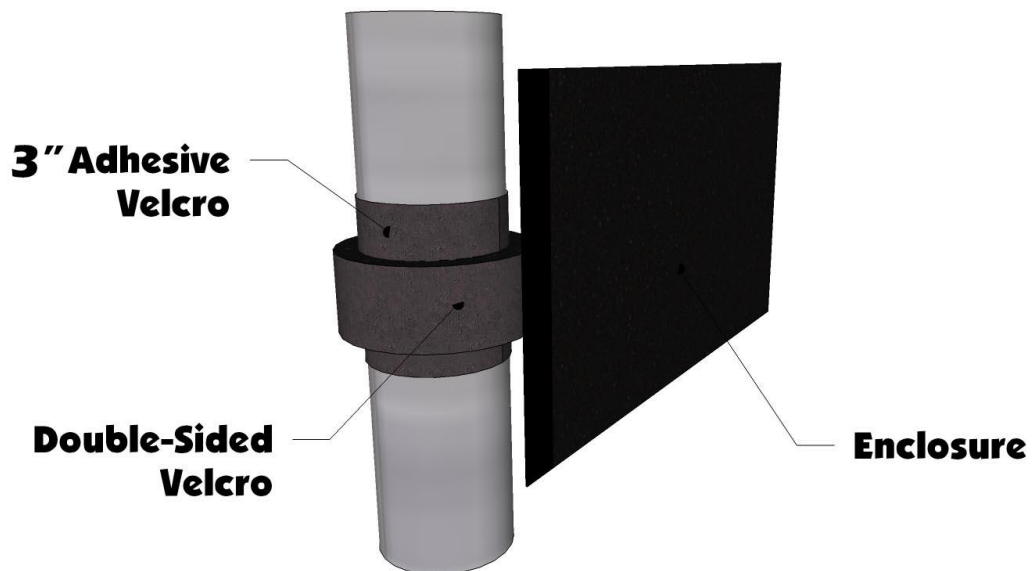
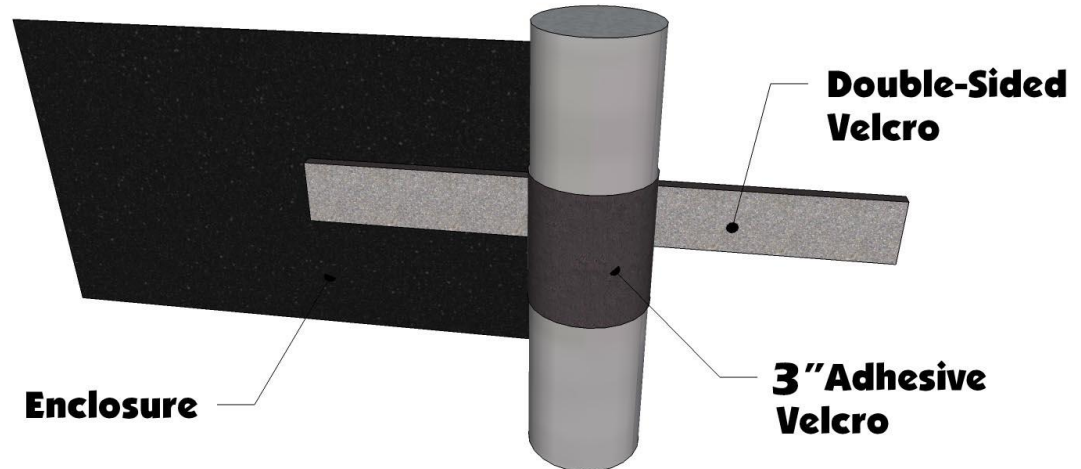

2. Next take the 38" adhesive Velcro strips and run it down the back of the roll cage facing towards the rear of the vehicle. Start at the bottom and work your way up the bar. You will see the double-sided Velcro tabs sewn along the back of the doors. See photos below.



3. Once all the Velcro is in place the last thing to do is install the screw snap studs. **NOTE: The best way to install the snap studs is to put them in the sockets in the door first. Then push them into the plastic to make a mark. Then pull the screw stud out and screw it into the plastic where the mark was made. See Photos Below.**



REAR WINDOW

4. Begin by placing the 30" adhesive Velcro strip centered across the top of the roll cage. Make sure to place them on top of the bar.
5. Next place the 55" strip across the bottom of the frame. It goes on the metal strip that faces the rear of the vehicle.
6. Then take the Rear Window and attach it across the bottom first making sure that it is centered properly. Pull it up and attach the top.
7. Next attach the sides of the Rear Window to the tabs on the back of the doors. See photo below.



POLYCARBONATE WINDSHIELD

8. Install using the directions included with the windshield.

TOP CAP

- a.** After the windshield is installed take the soft Top Cap and put it over the top of the vehicle and make sure you have the on correctly. When put on correct the sides will match up with the shape of the roll cage. On the front you will take the shorter straps and wrap the looped end around the roll cage just below the bottom clamp on the top section of the windshield. Run the other end of the strap through the loop and pull it tight. Then run the strap up and through the buckle sewn to the corner of the top. The front strap should look like the photo below.



- b.** Next take the other two long straps and wrap them around the roll cage in the rear just under door and rear window at the very bottom of the roll cage. Pull the strap up and connect to the buckle at the rear of the top.



c. Diagram below shows how to use ladder buckle.

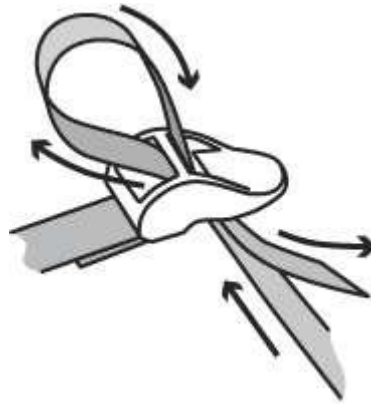

d. Now run those straps up and through the ladder lock buckles sewn to the rear of the top.

e. You now need to tighten and loosen the strap of the top so that it is centered correctly.

Cleaning and Storage Recommendations:

1. Before removing the Over Armour Cab for storage, make sure it is very clean in order to prevent scratching of the window panels. Clean with a soft rag or sponge using a mild liquid detergent soap and warm water solution. Never rub the windows with a dry cloth or rag! Let the Cab dry thoroughly before attempting to roll for storage.
2. It is important that the Cab be rolled up for storage rather than folding. Folding will cause damage to the windows!!! Carefully roll up the Cab similar to the way it was when it was packed at the factory. On a large, clean and flat surface, fold the doors over the rear panel first, then, interleave the top and windshield on top of the doors. Begin rolling the Cab into a roll approximately 8 inches in diameter. Put the rolled Cab back into the carton for storage at a normal room temperature. It is best not to expose the Cab to either extreme hot or cold temperatures when storing.
3. A special cleaner conditioner is available from Over Armour that will greatly increase the service life of the Cab Enclosure. In addition, if additional hook and loop sets are needed, they can also be ordered.