

Kawasaki Mule Pro FXT

Plow Mount

Part #: 105620
 Hardware Kit: HK-154

Contents:

- 1x 105621 - Plow Mount
- 2x 105624 - Backer Plate

Hardware Kit:

- 4x 3/8"-16 x 2-1/2" Square Neck Carriage Bolt
- 4x 3/8"-16 x 1" Hex Flange Bolt
- 8x 3/8"-16 Hex Flanged Nylock Nut

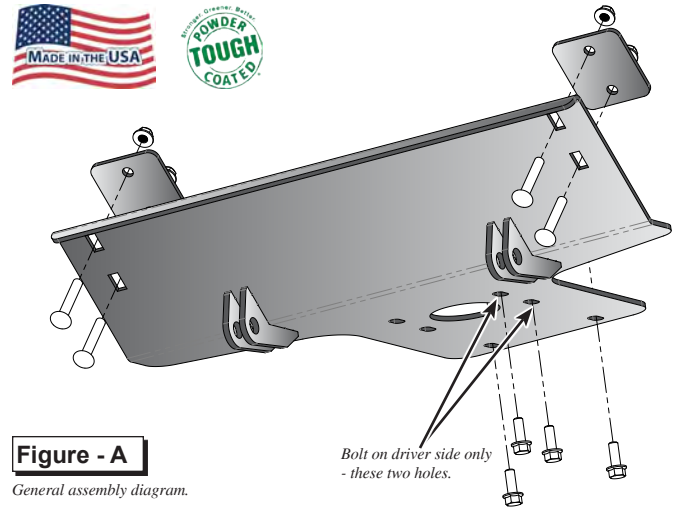
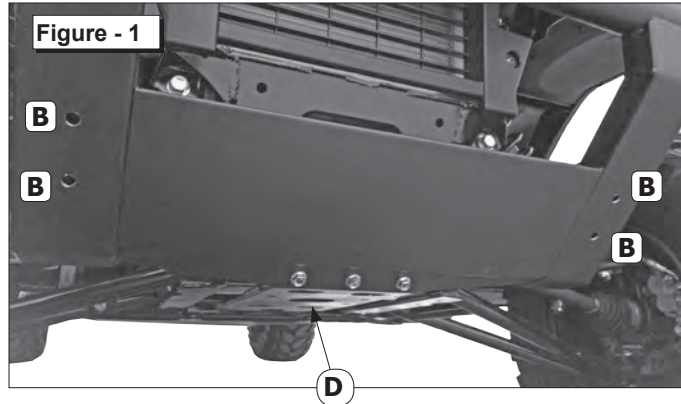

Figure - A
 General assembly diagram.

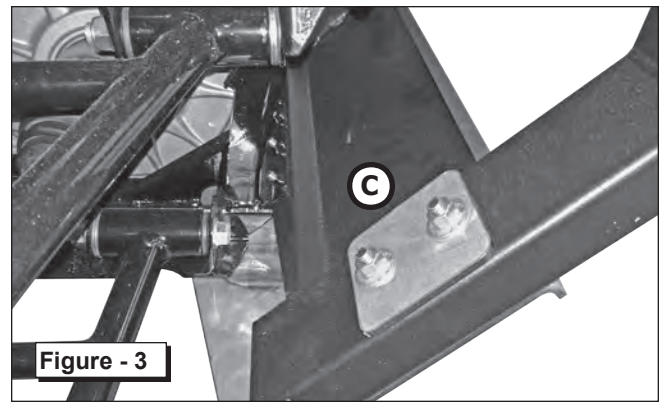
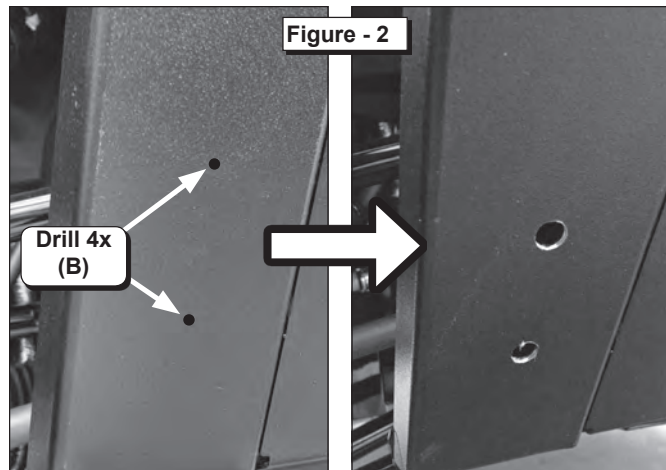

Figure - 3

INSTALLATION INSTRUCTIONS:

PREPARE MACHINE

1. Locate the four small pilot holes on the front lower bumper of the vehicle as noted at locations **(B)** in **Figures 1 & 2**. You need to drill these holes out to allow for hardware installation.
2. Using a 7/16" drill bit, drill out the four holes at locations **(B)** thru the front wall of the bumper tubes. (See **Figure 2**)



3. Position the Plow Mount plate against the front bumper as shown in **Figure 4**, and temporarily hold it in place. Assemble to the vehicle according to **Figure A**. Run four 3/8"-16 Carriage Bolts **(F)** through holes

at locations **(B)**. Place a Backer Plate **(C)** over the Carriage Bolts (see **Figure 3**) and sandwich the tube by loosely affixing four 3/8" Hex Flanged Nylock Nuts as shown in **Figure 3**. Work one side at a time. Repeat opposite side.

4. From under the vehicle, align the drain hole **(D)** and bolt pattern **(E)**. Install four 3/8"-16 x 1" Hex Flanged Bolts and Nuts at locations **(E)** as shown in **Figures A & 4**. Install the forward two bolts to the driver side only.
5. Finalize installation by fully and evenly tightening all hardware.

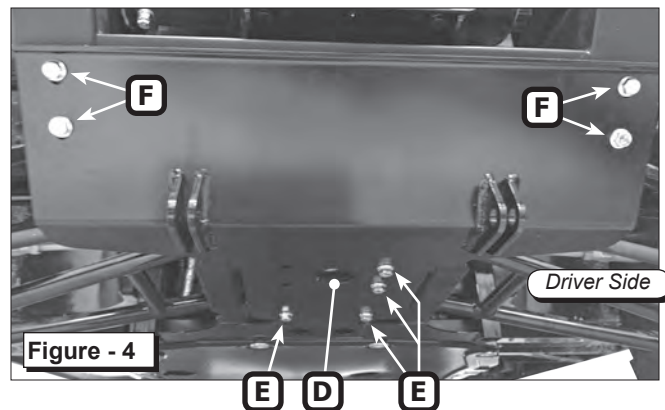

Figure - 4