



FALCON RIDGE

2515 Bypass Rd. Flemingsburg, KY 41041

606-845-7439

Instructions for Installation and Care of

Kawasaki Pro MX

Soft Door Kit

KAW-PROMX-SDK01

Notice: Do not smoke inside the cab or expose the enclosure to direct flames. Cab is Flammable.

1. Be sure to read these instructions thoroughly before opening and installing the Kawasaki Pro MX Soft Door Kit. The installation is best done when the temperature is 70 degrees F. or warmer. The temperature affects the adhesive Velcro, if conditions prevent installing in warmer weather it helps to store the adhesive Velcro at room temperature prior to installation.
2. Carefully open the carton and remove the enclosure on a large flat surface that is clean and free of dirt.
3. Check over the parts included in the carton with the parts list shown below:

	<u>Doors</u>
Adhesive Velcro Hook Strips:	18 each-----3”
“ “ “ “	4 each-----4”
“ “ “ “	2 each-----6”
“ “ “ “	2 each-----17”
“ “ “ “	2 each-----32”
Cab Enclosure	2panels

DOORS

1. Begin by installing the doors. If possible, have someone else hold the door in place and mark the location of each Velcro strip sewn along the **top and front** edges of the door. Now take the supplied 3” adhesive Velcro strips and wrap them around the roll cage at the marked locations. Now put the door back onto the vehicle and wrap the double-sided Velcro around the adhesive Velcro as shown in the photos below.



2. The rear edge of the door has a strip double-sided Velcro tab. Place the 17" adhesive hook strip down the rear of the roll cage. You will need to cut the Velcro so it adheres to each part of the frame. See photos below.



3. The diagrams below show how the double-sided straps and the 3" adhesive Velcro works.

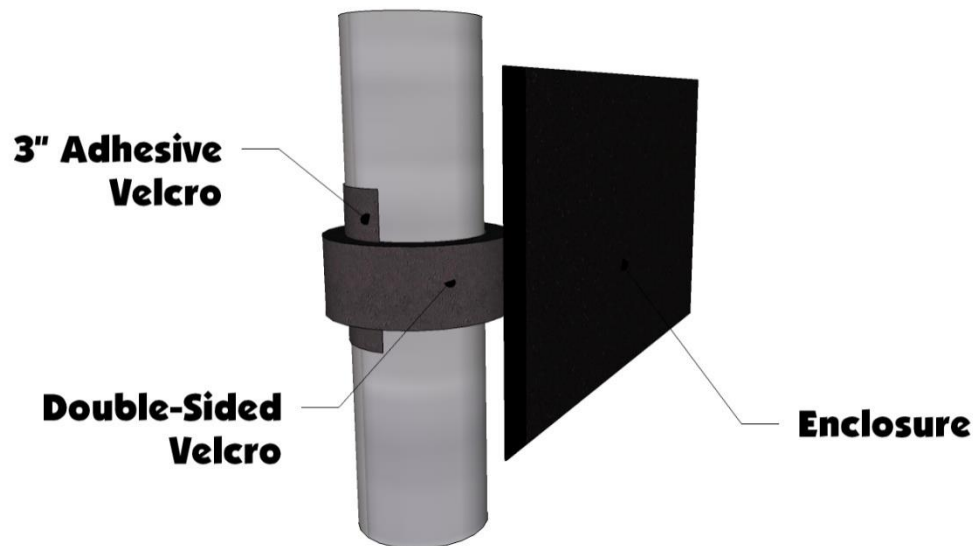
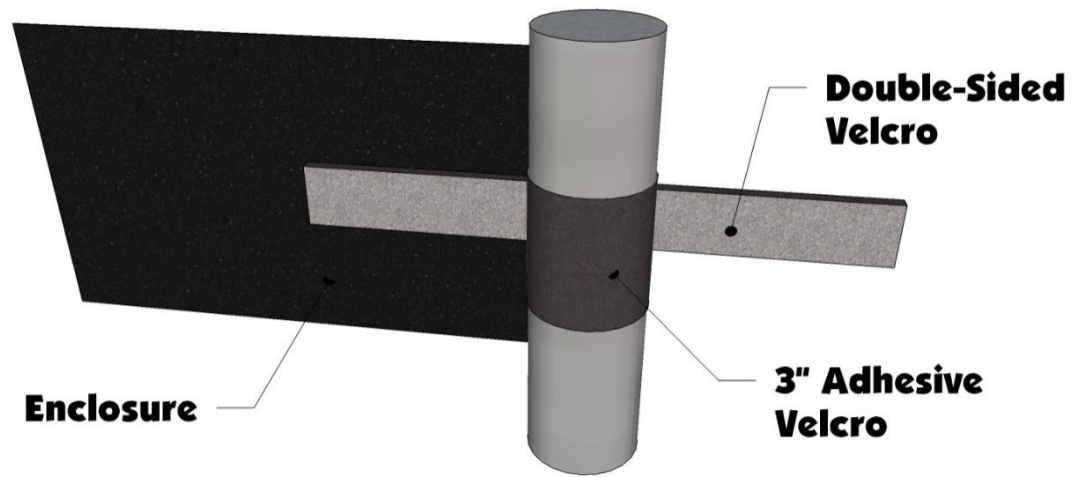

4. The bottom corner of the door is held in place by 6" and 32" adhesive Velcro strips. The photo below shows the proper placement.



Cleaning and Storage Recommendations:

1. Before removing the Falcon Ridge Cab for storage, make sure it is very clean in order to prevent scratching of the window panels. Clean with a soft rag or sponge using a mild liquid detergent soap and warm water solution. Never rub the windows with a dry cloth or rag! Let the Cab dry thoroughly before attempting to roll for storage.

2. It is important that the Cab be rolled up for storage rather than folding. Folding will cause damage to the windows!!! Carefully roll up the Cab similar to the way it was when it was packed at the factory. On a large, clean and flat surface, fold the doors over the rear panel first, then, interleave the top and windshield on top of the doors. Begin rolling the Cab into a roll approximately 8 inches in diameter. Put the rolled Cab back into the carton for storage at a normal room temperature. It is best not to expose the Cab to either extreme hot or cold temperatures when storing.

3. A special cleaner conditioner is available from Falcon Ridge that will greatly increase the service life of the Cab Enclosure. In addition, if additional hook and loop sets are needed, they can also be ordered.