

# Over Armour Offroad

2515 Bypass Rd. Flemingsburg, KY 41041

606-845-7439

## Instructions for Installation and Care of

### Honda Talon

### Soft Door Kit

### HO-TALON-SDK01

**CAUTION: Do not smoke inside the cab or expose the enclosure to direct flames. Product is FLAMMABLE.**

Be sure to read these instructions thoroughly before opening and installing the enclosure. The installation is best done when the temperature is 70°F or warmer. If installed outside and in the cold weather, warming the adhesive Velcro strips just before installation is recommended.

1. Carefully open the carton and roll out the enclosure on a large flat surface that is clean and free of dirt or other material that may soil the textile or scratch the clear vinyl windows of the enclosure.
2. Check over the parts included in the carton with the parts list shown below:

Velcro hook strips	26 each	3" long
Velcro hook strips	2 each	6" long
Velcro hook strips	2 each	40" long
Cab enclosure	2 Pieces	
3. Begin by opening up the enclosure and with the help of another person drape the enclosure over the roll cage and arrange into the correct position.
4. You will notice double-sided Velcro strips sewn to the cab enclosure. At these locations, wrap the roll bar with one of the 3" adhesive Velcro strips. After wrapping the Velcro around the bar wrap the double-sided strip around the adhesive Velcro providing a very secure hold. Pictures on next page show how this works.



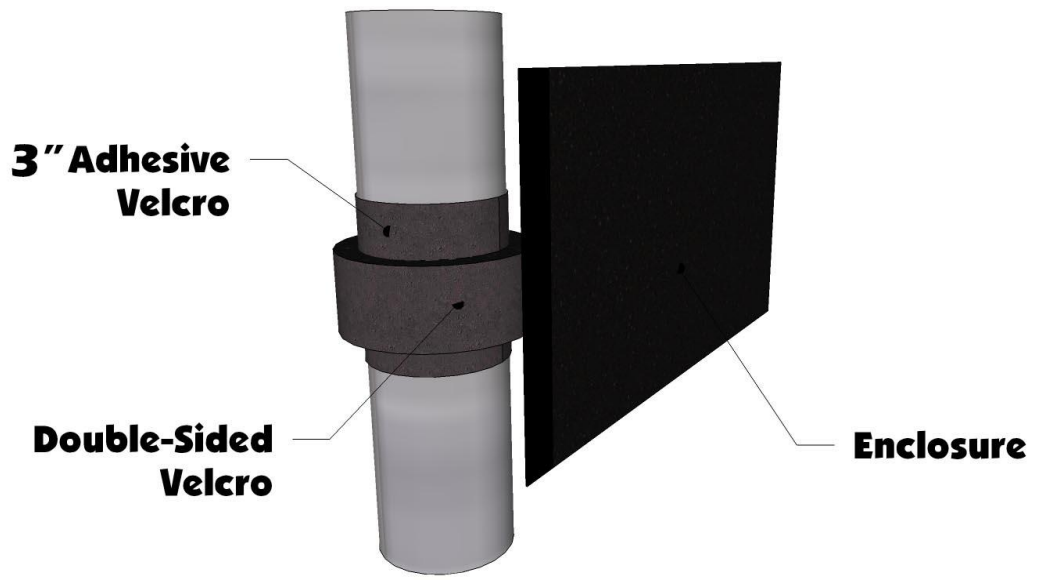
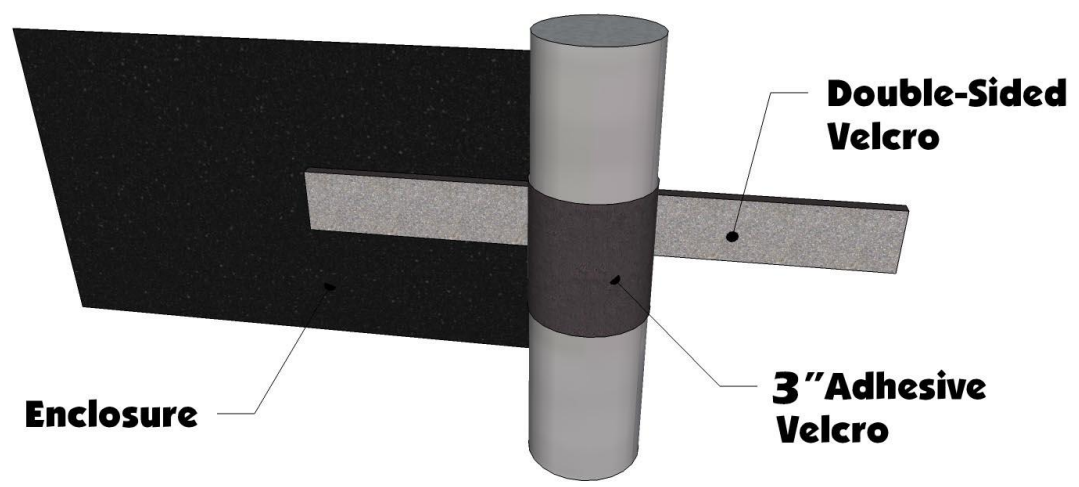
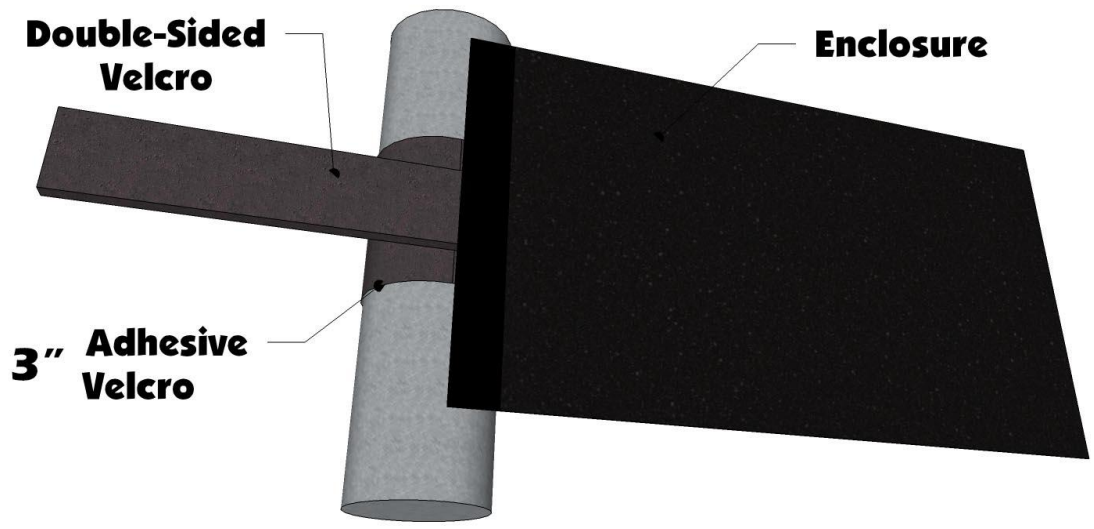

5. After attaching the double-sided strips go to the bottom of the door. Pull the bottom of the door up and place the 40" adhesive strip on the Velcro sewn to the door. Leave the paper backing on it as you put it on then peel it off after getting it in place. See Photos below.



6. Then pull the bottom of the door down and attach it to the Talon door. Make sure to rub it down good before peeling the door back off the Velcro.
7. Remove the bottom of the door and take a knife and cut the Velcro where the back of the door hinges at. See photo below



8. Next place the 6” adhesive strips on the vehicle to match up with the front portion of the door as shown in the photo below.



9. Lastly place the other 6” adhesive strips on the vehicle to match up with the Velcro on the very front bottom part of the door as shown below.



## **Cleaning and Storage Recommendations:**

1. Before removing the enclosure for storage, make sure it is clean and dry, to prevent soiling the textile and scratching the clear vinyl side/rear windows. Clean with a soft rag or sponge using a mild liquid detergent soap and warm water solution. Let the enclosure dry thoroughly before attempting to roll for storage.
2. It is important that the enclosure be rolled up for storage rather than folding. Folding will cause undesirable creasing of both the enclosure textile and the clear vinyl side/rear windows. Carefully roll up the enclosure similar to the way it was when it was packed at the factory. On a large, clean, and flat surface, fold the doors over the rear panel first, then, interleave the top and windshield on top of the doors. Begin rolling the enclosure into a roll approximately 8" in diameter. Put the rolled enclosure back into the carton for storage at a normal room temperature. It is best not to expose the enclosure to either extreme hot or cold temperatures when storing.
3. A special cleaner/conditioner is available from Over Armour that will greatly increase the service life of the cab enclosure. If needed, additional hook and loop sets are available, as well as other spare parts and hardware. Contact Over Armour for information.
4. Transporting or trailering your UTV with the enclosure installed is not generally recommended. It is best to remove the enclosure before transporting your UTV.

**Thank you for your purchase!**

## Return Policy

If for any reason you choose to return this product it must be returned within **30 days from date item is received**. You **MUST** package the product exactly **as it was originally packaged from the factory to get a full refund for the product!**

The vinyl windows should never be folded when packaging in the box or for storage purposes. Lay all the windows on top of each other with the canvas folded in between and the paper (if available) on both sides of the windows.

**All returned products will be inspected upon arrival at the production facility and must be in unused, factory new condition to receive refund - a 25% restocking fee will apply.**

If ordered from Over Armour Offroad please call at 606-845-7439 to gain a return authorization number, use our preferred shipping carrier (UPS) to return the item (unless the item is defective, you are responsible for paying the shipping to return the item.) **Any returns submitted to Over Armour Offroad without a return authorization number will be charged a 20% restocking fee.** If ordered from one of Over Armour Offroads many distributors', you must first call them and see what their return policy is. Once your item reaches our production facility, our customer satisfaction team will inspect your item to ensure unused, factory new condition. **NOTE: All windshields must be returned with the original protective film intact and not removed. Do NOT REMOVE if you have any intentions of returning the item. Refund/ replacement of a windshield will only be processed on items with original protective film or if the windshield is defective.**

Items must be properly packaged in the original shipping carton to protect them during transit and ensure your returned item arrives back factory fresh, and in new resalable condition (**any returned items that have been used, altered or damaged in any way will not be subject for a refund.**) All contents including instruction manuals, accessories, hardware, Velcro, etc. must be included in your return shipment. Only items in OEM factory new condition will be approved. Once returned items are received, credit will be issued to the original credit card/ payment method used for the purchase. Outbound shipping and return shipping cost will not be refunded. Please allow 4 to 6 weeks for your refund to be processed.

## Warranty

To The Owner of this Product:

Thank you for purchasing one of Over Armour Offroad Cab Enclosures, Tops &/or Windshields!  
Below are the terms under which your product is covered under our manufacturer's warranty.

30 Day Warranty which includes and is not limited to replacing the enclosure, tops and/or windshield due to defect of the product. Please refer to the return policy in this case for more information.

1 Year Warranty includes any defect in material or workmanship within this time frame we will gladly correct the problem or replace the enclosure, tops &/or windshield. Upon submitting for the correction or replacement we will need to receive pictures of the defect in material or workmanship along with the receipt from the date of purchase.

Thank you,

Over Armour Offroad  
[www.overarmouroffroad.com](http://www.overarmouroffroad.com)