

Over Armour Offroad

2515 Bypass Rd. Flemingsburg, KY 41041

606-845-7439

Instructions for Installation and Care of

Honda Talon

Aero-Vent Poly Rear Window

HO-TALON-RW03

Notice: Do not smoke inside the cab or expose the enclosure to direct flames. Cab is Flammable.

1. Be sure to read these instructions thoroughly before opening and installing the Honda Talon Aero-Vent Rear Window.
2. Check over the parts included in the carton with the parts list shown below:

1" Bolts	6 each
2" Bolt	1 each
2" Loom Clamps	4 each
1 ¼" Black Nylon Spacer	1 each
1 ½" Loom Clamps	2 each
Small Washers	6 each
Lock Nuts	1 each
Slide Fasteners	5 each
Thumb Nuts	6 each
3. Begin by peeling the protective film from both sides of the Rear Window and vent slider. Then proceed to install the vent slider on the inside surface.
4. Take the 2" Bolt, Black Nylon spacer and locknut and install it on either side of the vent slider. Slide the spacer over the bolt and then put the bolt in the hole at the top middle of the vent slider. Then screw the lock nut on the other side and tighten it down
5. Next place the slider on the inside surface of the rear window so that the lock nut is in the large slot. Then install the 5 slide fasteners through the slots of the slider panel and into the small holes in the rear window. Should look like picture below when finished

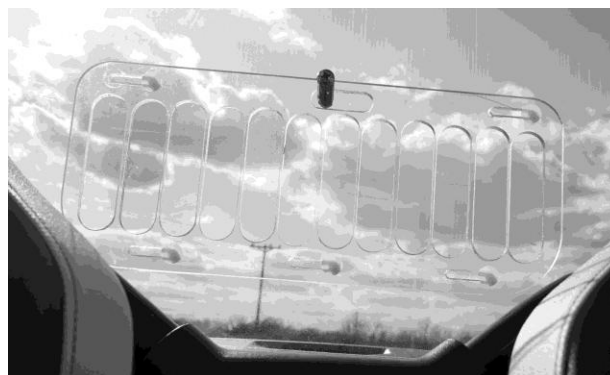

6. From the side install the Rear Window through the rear down bars and get it in place so that it sits flush up against the outside of the roll cage.
7. Down the sides of the Rear Window are two slots. Using the 2" loom clamps attach the window as shown in the diagram below.

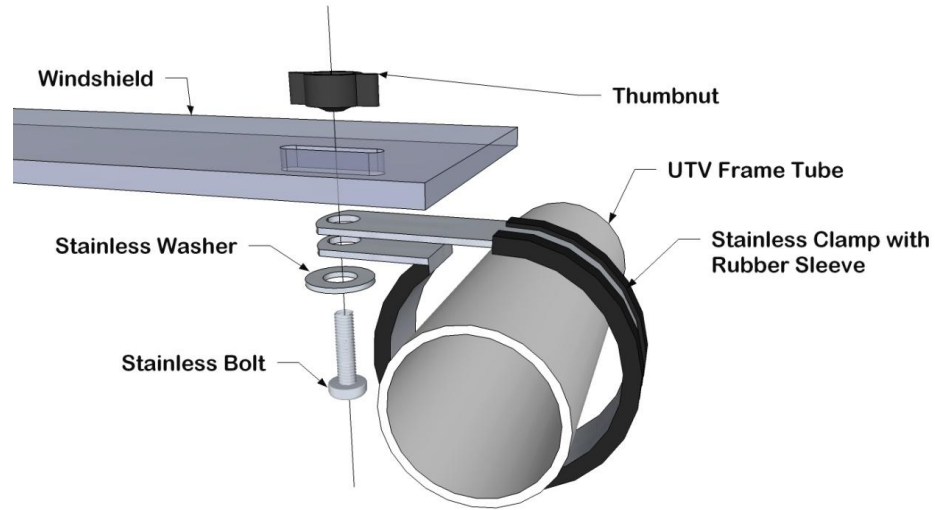

8. Along the bottom use the two 1 ½" clamps the attach the rear window as you did along the sides. The following pictures show where all the clamps go.





9. This concludes your installation. Enjoy!!

Over Armour Offroad
2515 Bypass Rd, Flemingsburg, KY 41041
Phone: 606-845-7439 or 606-748-5136

If for any reason you choose to return this product it must be returned within **30 days from date item is received**. You **MUST** package the product exactly **as it was originally packaged from the factory to get a full refund for the product!** The vinyl windows should never be folded when packaging in the box or for storage purposes. Lay all the windows on top of each other with the canvas folded in between and the paper (if available) on both sides of the windows.

All returned products will be inspected upon arrival at the production facility and must be in unused, factory new condition to receive refund - a 25% restocking fee will apply.

If ordered from Over Armour Offroad please call at 606-845-7439 to gain a return authorization number, use our preferred shipping carrier (UPS) to return the item (unless the item is defective, you are responsible for paying the shipping to return the item.) **Any returns submitted to Over Armour Offroad without a return authorization number will be charged a 20% restocking fee.** If ordered from one of Over Armour Offroad many distributors', you must first call them and see what their return policy is. Once your item reaches our production facility, our customer satisfaction team will inspect your item to ensure unused, factory new condition. **NOTE: All Lexan windshields must be returned with the original protective film intacked and not removed. Do NOT REMOVE if you have any intentions of returning the item. Refund/ replacement on lexan windshields will only be processed on items with original protective film or if the windshield is defective.**

Items must be properly packaged in the original shipping carton to protect them during transit and ensure your returned item arrives back factory fresh, and in new resalable condition (**any returned items that have been used, altered or damaged in any way will not be subject for a refund.**) All contents including instruction manuals, accessories, hardware, Velcro, etc. must be included in your return shipment. Only items in OEM factory new condition will be approved. Once returned items are received, credit will be issued to the original credit card/ payment method used for the purchase. Outbound shipping and return shipping cost will not be refunded. Please allow 4 to 6 weeks for your refund to be processed.

Warranty

To The Owner of this Product:

Thank you for purchasing one of Over Armour Offroad Cab Enclosures, Tops &/or Windshields! Below are the terms under which your product is covered under our manufacturer's warranty.

30 Day Warranty which includes and is not limited to replacing the enclosure, tops and/or windshield due to defect of the product. Please refer to the return policy in this case for more information.

1 Year Warranty includes any defect in material or workmanship within this time frame we will gladly correct the problem or replace the enclosure, tops &/or windshield. Upon submitting for the correction or replacement we will need to receive pictures of the defect in material or workmanship along with the receipt from the date of purchase.

Thank you,

Over Armour Offroad
www.overarmouroffroad.com