

Installation & Operations Manual : FR Flip-Up Windshield, Polaris Full-Size Pro-Fit Ranger

Installation Information:

This product does not require any modifications to your vehicle. Please familiarize yourself with all the steps before beginning assembly.

Falcon Ridge was established to help UTV owners adapt their vehicles for the great outdoors, Falcon Ridge provides innovative, practical, and rugged UTV products to provide owners the confidence to work, play, or explore in whatever conditions they may encounter.

Were fueled by your passion!

Parts List:

1. 50-50219; 50-50837 FS Ranger Windshield
2. 54-91032 Gasket
3. 54-96047 Tube Assembly
4. 54-96061 Brace Mounting Block Cover
5. 54-96064 T Handle
6. 54-96058 Shim (2)
7. 54-96080 Ball Bracket, Driver
8. 54-96081 Ball Bracket, Pass.
9. 54-96086 Gas Spring (2)
10. 54-96071 Center Retainer
11. 54-96072 Rub Plate
12. 54-96082 Strike Plate, Driver
13. 54-96083 Strike Plate, Pass.
14. 54-96085 Hinge Half, Upper (2)
15. 54-96084 Hinge Half, Lower (2)
16. 54-96055 Ball Stud Clamp (2)
17. 54-96056 FS Ranger Hardware Bag

Tools Needed:

- 4mm, 5mm, 6mm Allen Wrenches
- 10mm, 12mm, 13mm Open End Wrench
- Socket Wrench with 13mm Socket
- Small Flathead Screwdriver

Installation Video



Scan code with your phone's camera and follow the link



Parts

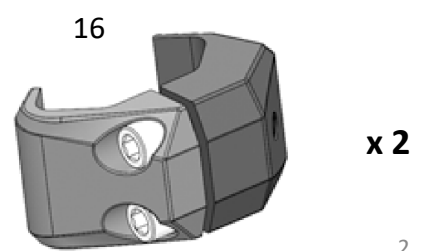
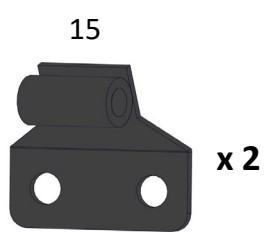
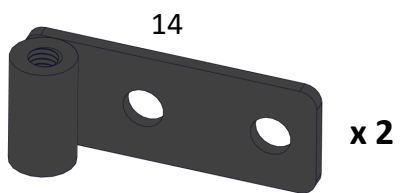
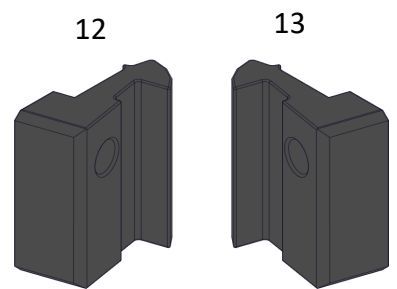
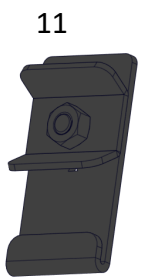
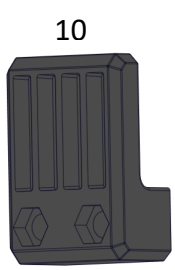
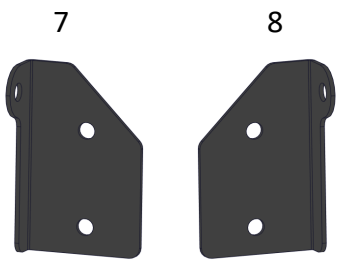
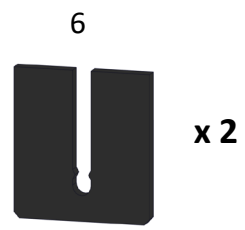
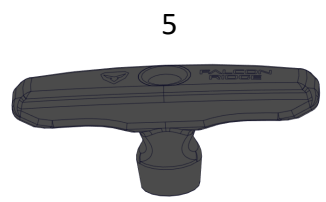
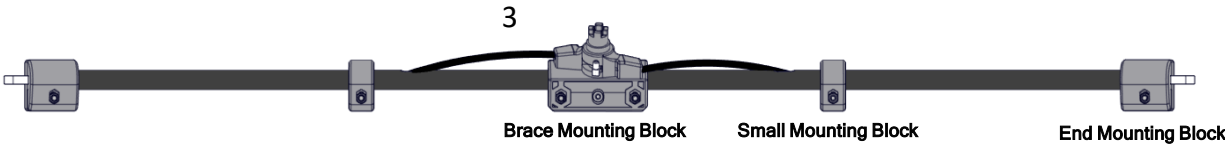
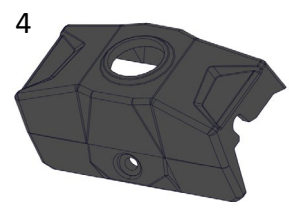
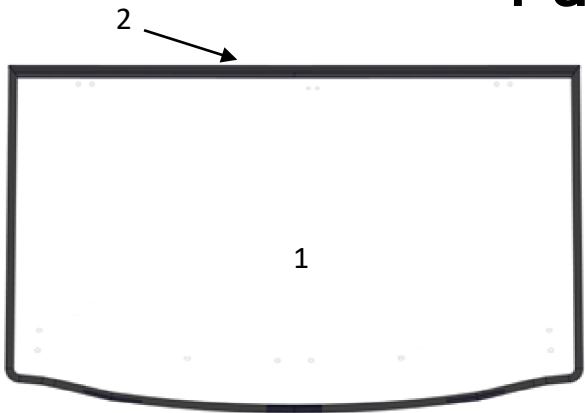

Hardware

In Tube Assembly:



In Hardware Bag:

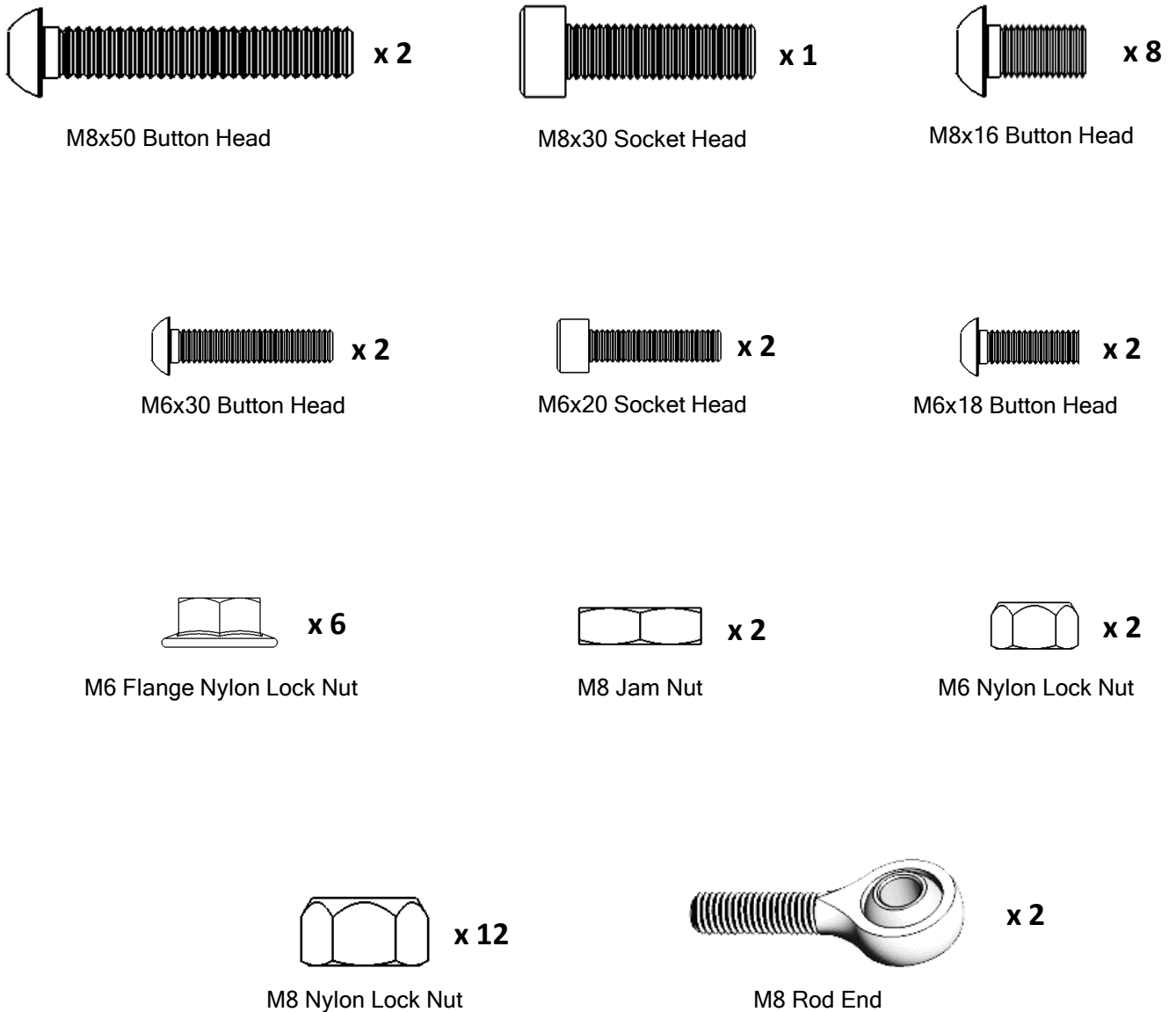

1

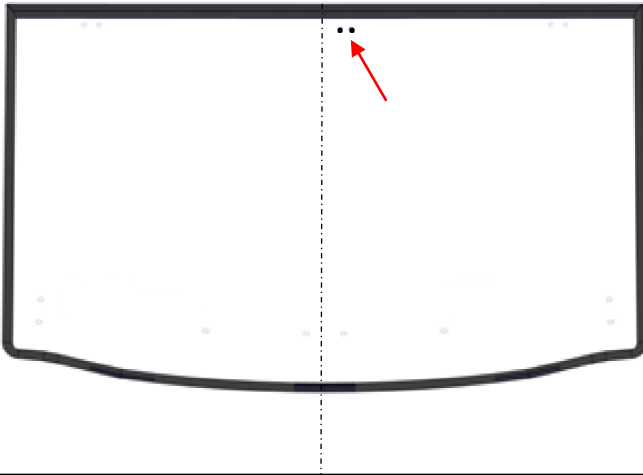

Place the windshield down on a large flat surface with something under it to prevent scratching. It should be oriented with **Gasket** bulb-side up. This is the inside of the windshield. There are two holes about 1.5" apart in the middle of the top of the windshield. Make sure they are slightly right of center.

2

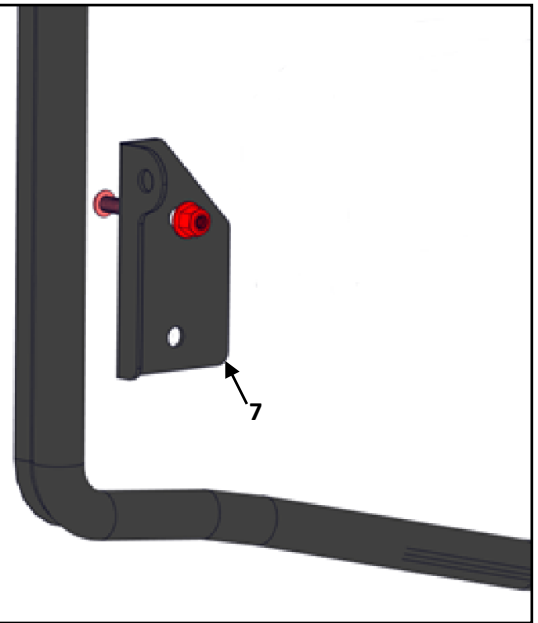

Take the **Ball Brackets** and orient them on the inside of the windshield as shown. Shown above is **Ball Bracket, Driver**. Gather a 4mm allen wrench and a 10mm open wrench. Fasten an **M6x18mm Button Head Bolt** through top hole in each ball bracket with a **M6 Flange Nylon Insert Lock Nut** on the inside of the windshield.

3



Repeat for the other half of windshield so that the windshield looks like this. Make sure the fasteners are tight, but you can still rotate the ball brackets by hand with some resistance.

4

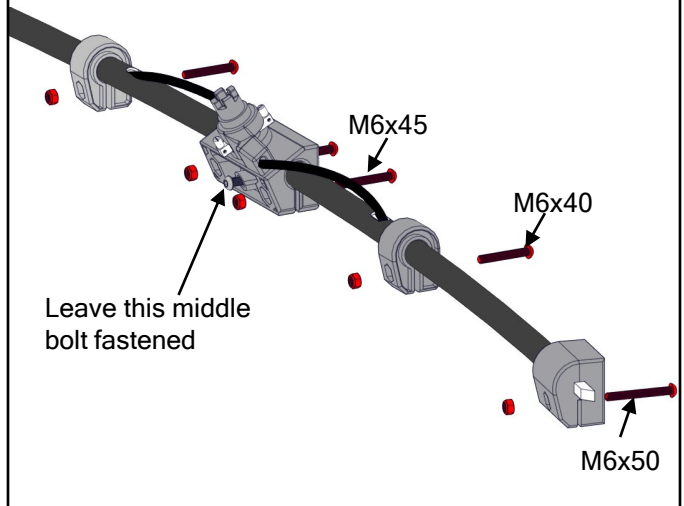

Take the **Tube Assembly** out of its box. The tube should be bowed with the latches curved in towards you. Using a 4mm Allen wrench, remove all the bolts and nuts from the mounting blocks except the **M6x45 Button Head Bolt** in the middle of the **Brace Mounting Block**. Use picture above to remember which size bolt goes with each mounting block.

5

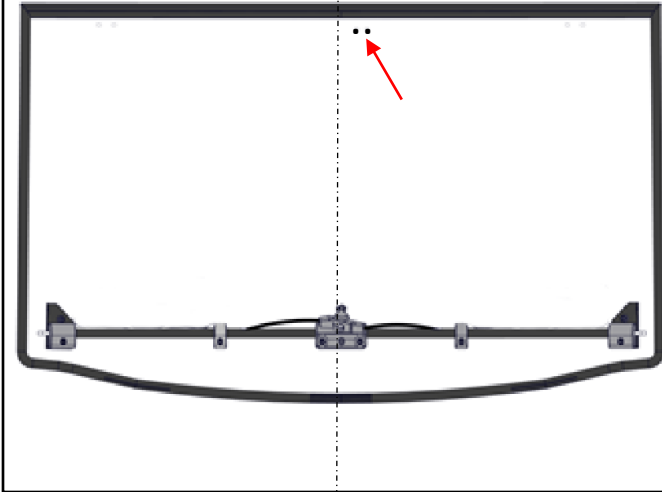

Place the **Tube assembly** on the inside of the windshield with the pockets for captive nuts in each of the mounting blocks facing upwards.

6

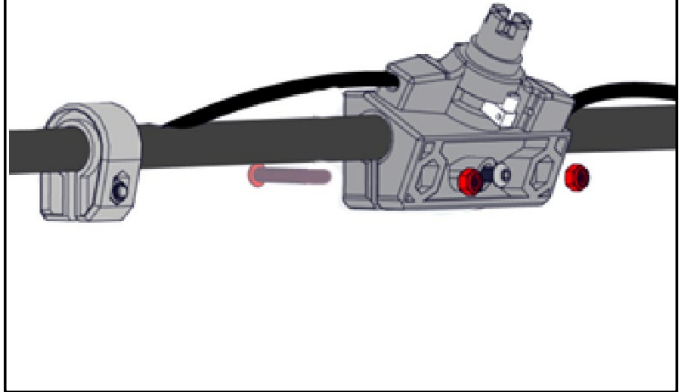

Insert two **M6x45 Button Head Bolts** through the windshield, and then through the **Brace Mounting Block**. Put the outer two **M6 Nylon Lock Nuts** in their captive pockets to fasten until just a few threads engage. At this point just tighten by hand or finger-tight using a 4mm Allen wrench.

7

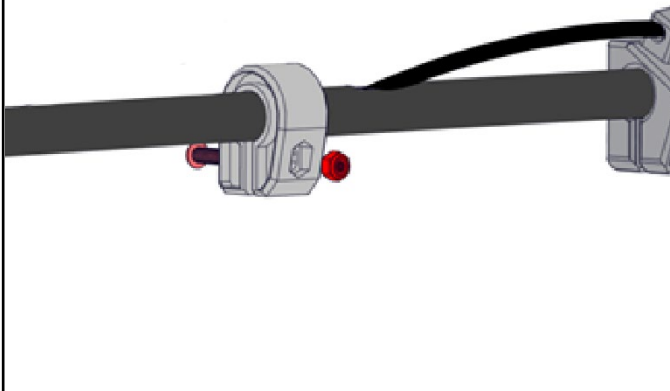

Use a **M6x40mm Button Head Bolt** and a **M6 Nylon Lock Nut** to repeat this process for each **Small Mounting Block**. *The hole alignment of the mounting blocks to the holes in the windshield can be adjusted at any time by rotating the tube within the mounting blocks. Because of this, it is important to leave all fasteners loose during steps 6-9.*

8

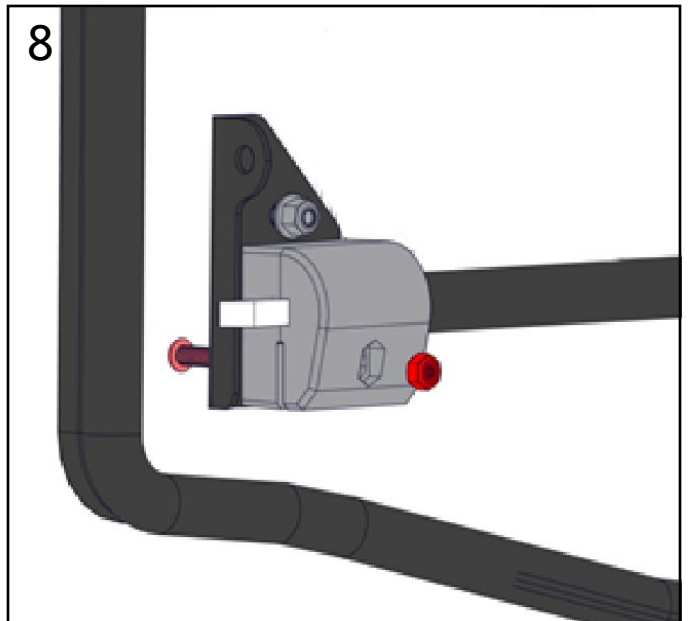

Check the alignment on the **End Mounting Blocks** and rotate the tube if needed. Now gently flex the windshield towards the tube so that you can insert a **M6x50 Button Head Bolt** through the other side of the windshield, through the bottom hole of the **Ball Bracket**, and then through the **End Mounting Block**. Use an **M6 Nylon Lock Nut** in the captive pocket to fasten the bolt. Only engage about 2-3 threads. Repeat for other side.

9

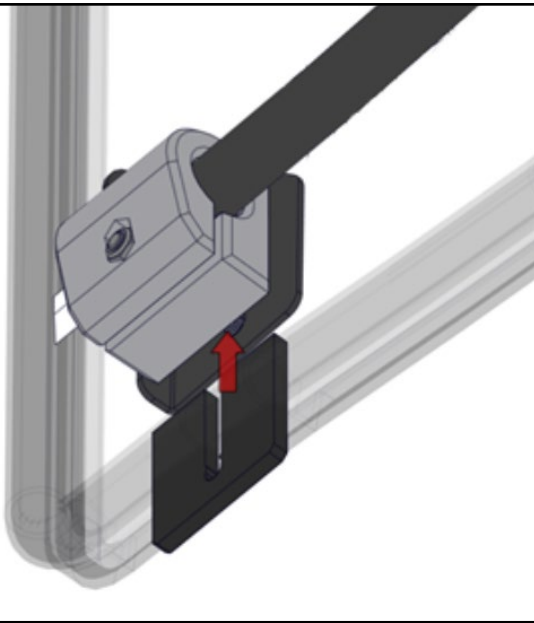

There is a gap for the **Shim** to be snapped in place over the **M6x50mm Button Head Bolt** in between the **End Mounting Block** and the **Ball Bracket**. Insert the shims in this gap in each side by snapping in from the bottom side of the windshield. Now, working from the middle out, tighten all bolts along the tube assembly except the middle bolt of the **Brace Mounting Block**

10

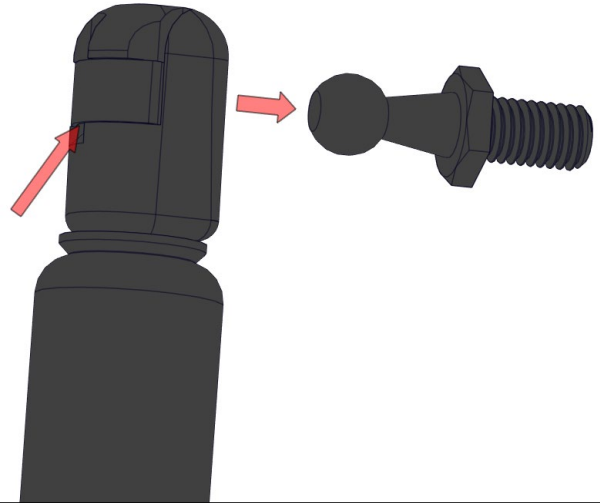

Remove the two M8 ball studs from each **Gas Spring**. There will be 4 total ball studs. Do this by prying up the metal retaining clip with a small flat blade screwdriver and pulling the ball stud out. Once the ball stud has been removed make sure the retaining clip is back in place.

11

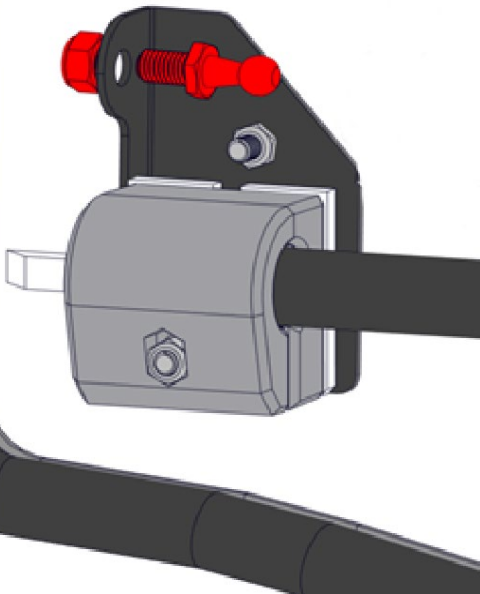

Install one Ball Stud onto each Ball Bracket using an **M8 Nylon Insert Lock Nut**. Orient the Ball to face inwards towards the middle of the windshield, and fully tighten using 12mm and 13mm open end wrenches.

12

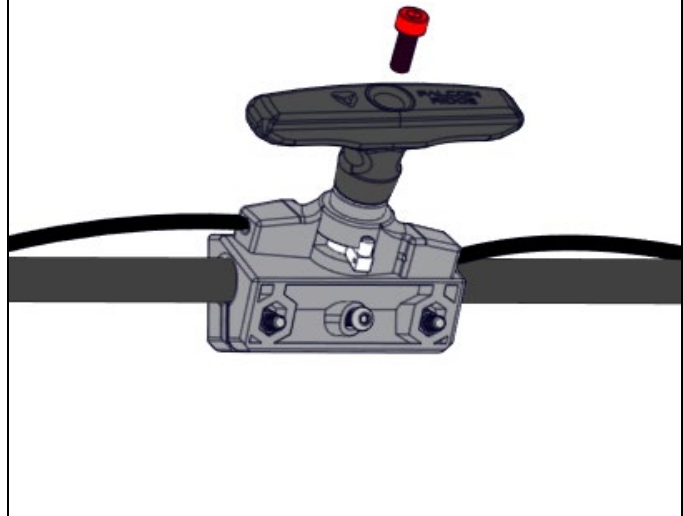

Install the **T Handle** onto the cylinder with the **M8x30mm Socket Head Bolt**. You will need a 6mm hex key.

13

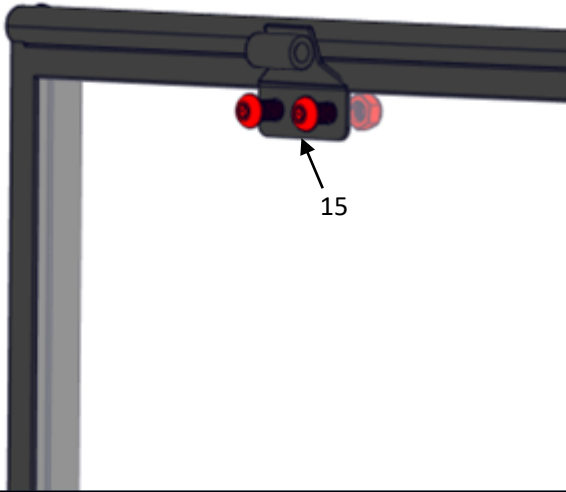

Now attach each **Hinge Half, Lower** to the outer side of the windshield with the angle coming away from the polycarbonate. Fasten loosely with 4 - **M8x16mm Button Head Bolts** and 4 - **M8 Nylon Insert Lock Nuts**. The bolt heads should be on the metal side and the nuts on the inside of the windshield

14

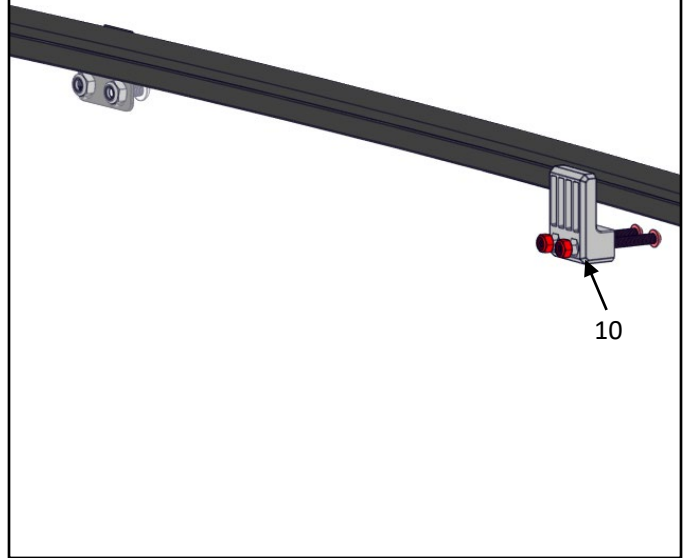

Now install the **Center Retainer** on the inside of the windshield using 2 - **M6x30 Button Head Bolts** and 2 - **M6 Nylon Lock Nuts**.

15

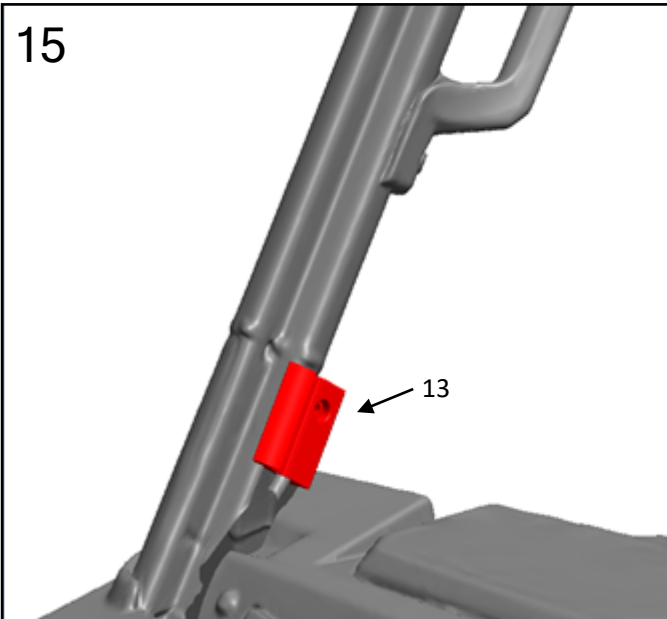

Shown is the **Strike Plate, Pass**. Orient the part as shown. Gather a 10mm open-ended wrench and a 5mm hex key.

16

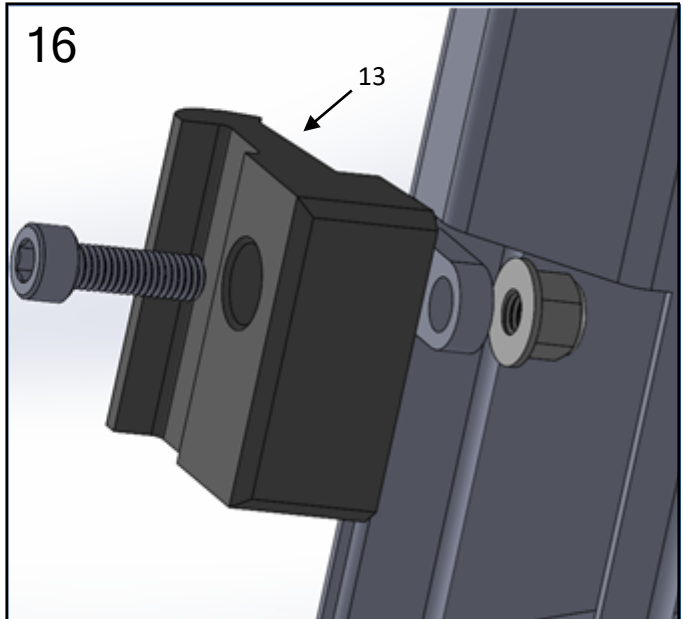

Use an **M6x20mm Socket Head Bolt** and a **M6 Flange Lock Nut** to attach the **Strike Plate** on each side of the vehicle. This step can be a little tricky. Insert the **M6x20mm Socket Head Bolt** through the **Strike Plate** and the hole in the welded tab while using the open end of a 10mm wrench to hold the flange nut in place. Once in place use a 5mm hex key to turn the socket head bolt. Make sure the **Strike Plate** stays aligned as shown. Repeat for the other side. If you drop a nut there are two extra in the hardware bag.

17

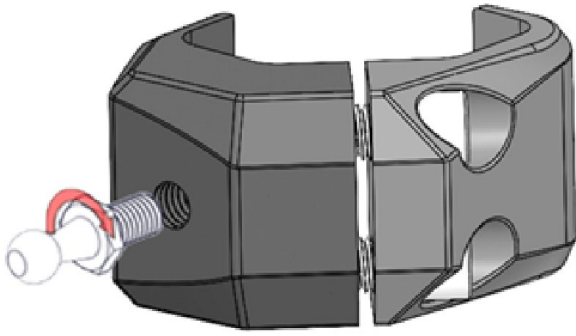

Thread one M8 Ball Stud into each **Ball Stud Clamp**

18

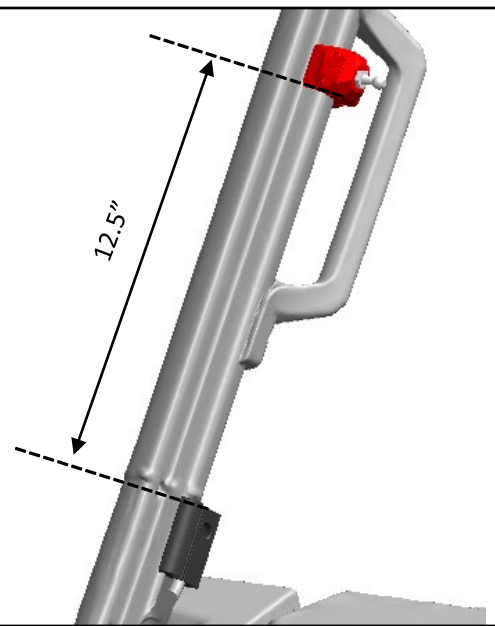

Attach the **Ball Stud Clamp** to the vehicle frame by loosening its two M8x30 Socket Head Bolts until able to fit clamp over the tubing. Space the **Ball Stud Clamp** from the **Strike Plate** so that its bottom edge is 12.5 inches away from the top edge of the strike plate. This will position the ball stud clamps properly for gas spring installation later. Tighten the M8x30 bolts very tight!

19

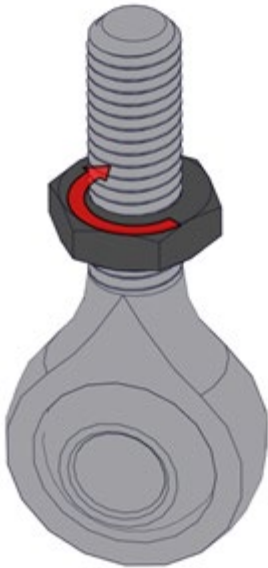

Thread one **M8 Jam Nut** onto each **Rod End** until the nut can go no further

20

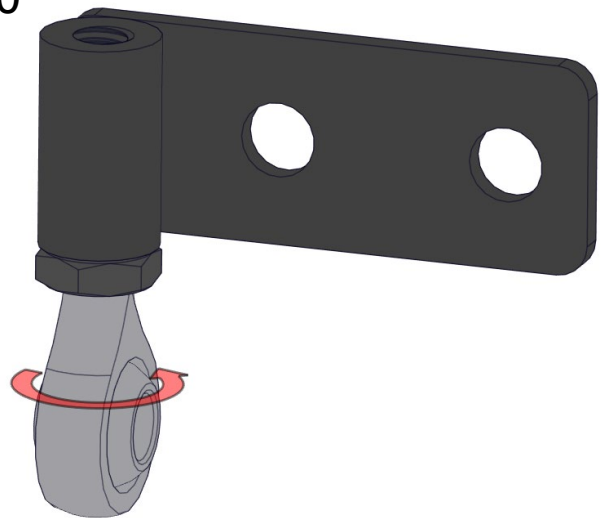

Thread each **M8 Rod End** into the **Hinge Half, Upper** as shown. This is the left upper hinge assembly. Mirror and repeat for the right side.

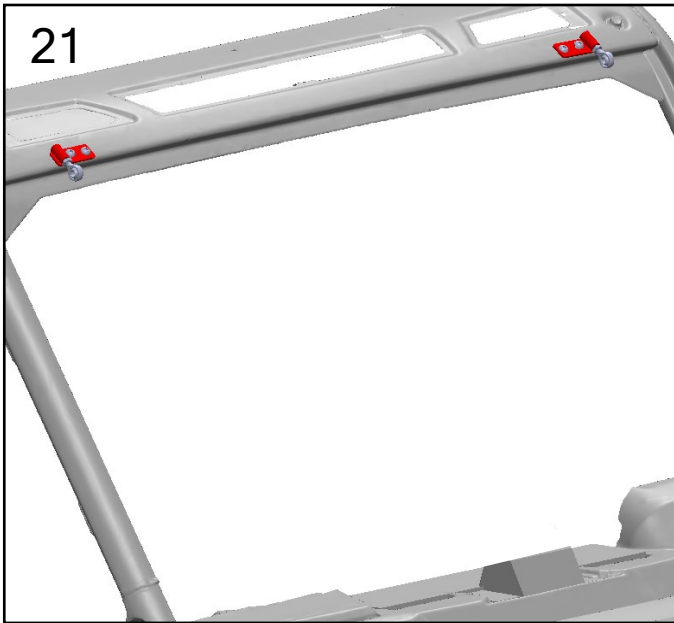

Shown above is both assembled **Hinge Halves, Upper** and their orientations on the frame of the vehicle.



Use a 5mm hex and a 13mm socket wrench to loosely fasten two **M8x16mm button head bolts** and two **M8 Nylon Lock Nuts** for each **Hinge Half, Upper** on each side of the vehicle. Driver side shown

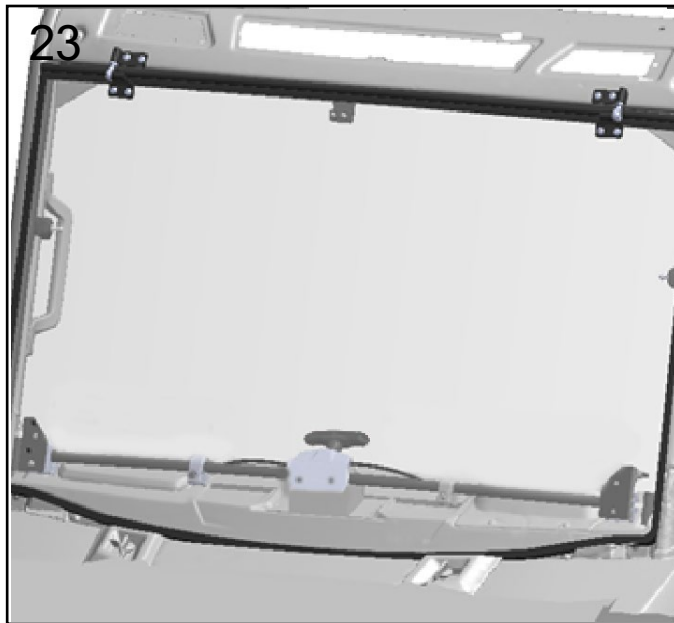

Taking care to keep the **Center Retainer** under the header panel, place the windshield on the frame of vehicle.

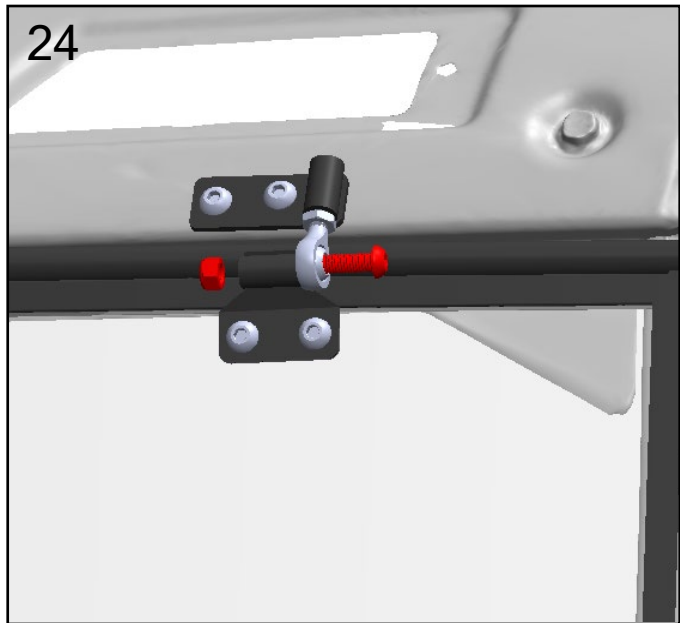

Line up the holes in each side of the top hinges and insert the **M8x50 button head bolt** first through the **Rod End** and then through the **Hinge Half, Lower** Use the **M8 Nylon Lock Nuts** to secure the bolt. Mirror and repeat on other side. Tighten both sides. The windshield can be horizontally aligned by tightening or loosening these bolts on each side Ensure the **Hinge Half, Upper** is located on the outside of the **Hinge Half, Lower** when installed. As seen above.

25

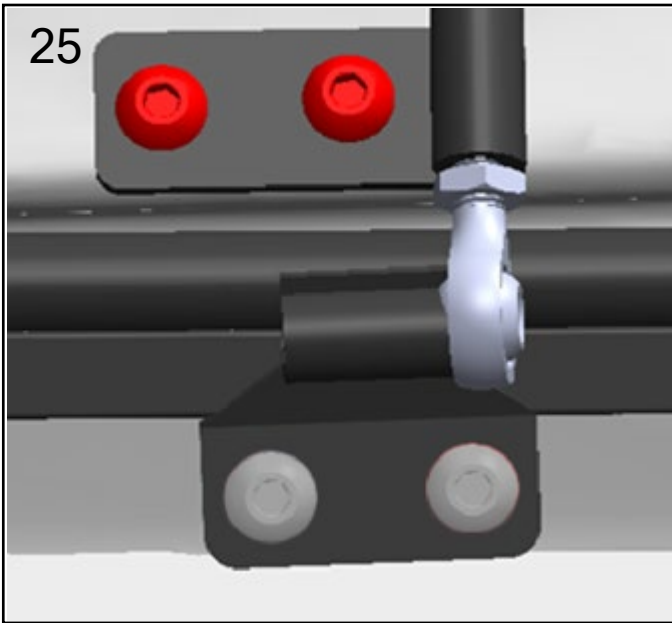

Check the alignment of the windshield. These two **bolts** on either side of the windshield can be loosened to allow for adjustment of the windshield alignment. Use a rubber mallet to tap them and align the windshield. Once aligned, tighten all bolts.

26

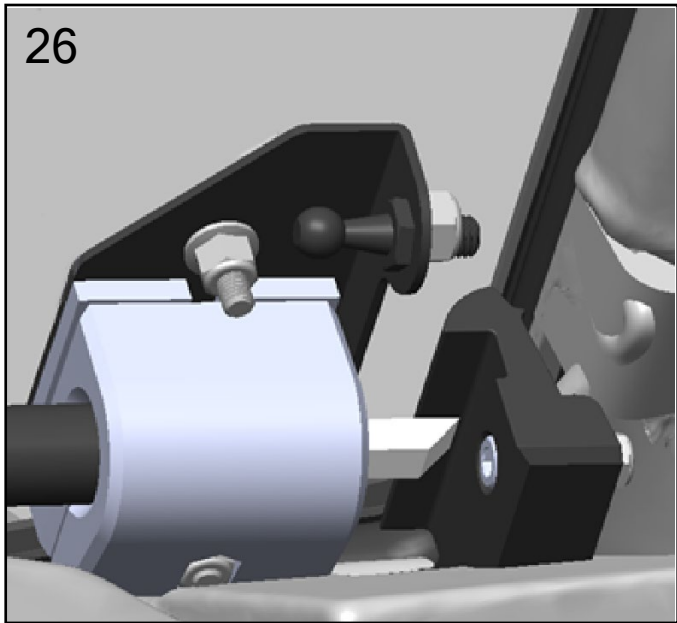

Press the bottom corners of the windshield in gently to latch the strikers in the **Strike Plates**. **do not slam the windshield closed yet *it isn't aligned yet and it may damage the **End Blocks** and/or **Strike Plates**.* Once both strikers are latched in the **Strike Plates** you can move to the next step.

27

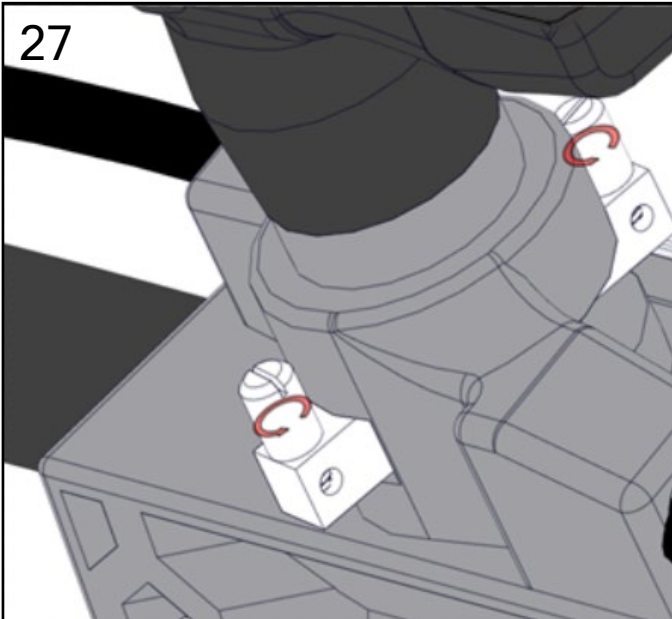

Now that both strikers are engaged in the **Strike Plates**, by loosening the two set screws shown above in the **Brace Mounting Block** the cable length can be changed so that the strikers bottom out in the **Strike Plates** without having any excess length that would make closing the windshield difficult. If there was not enough length originally, when you loosen the screws above, the strikers should then bottom out in the **Strike Plates** (you may have to compress the gasket near the strike plates by hand to facilitate this) Pull on the cut end of the cable to remove any slack and then re-tighten the screw. Repeat for other cable.

28

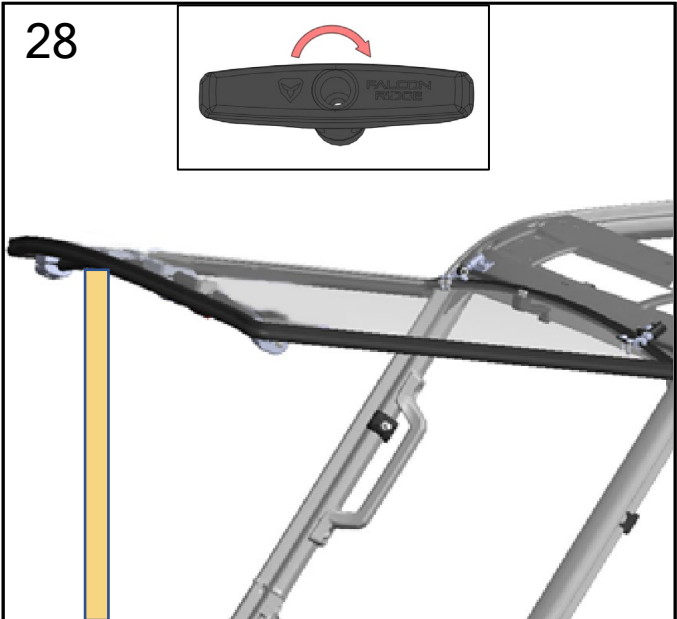

Twist the **T Handle** to open the windshield and lift it until it is parallel with the ground. Have a helper (or stick) hold the windshield in this position. You will need it to be open while you do the next few steps.

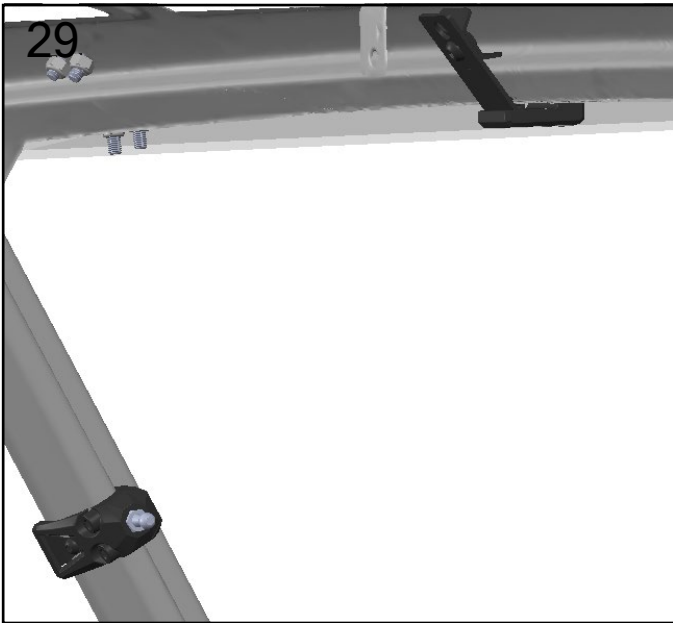

With the windshield held open, install the **Rub Plate**, from inside the vehicle, by sliding the hooked piece under the center retainer and then fastening to the piece shown in the next step.

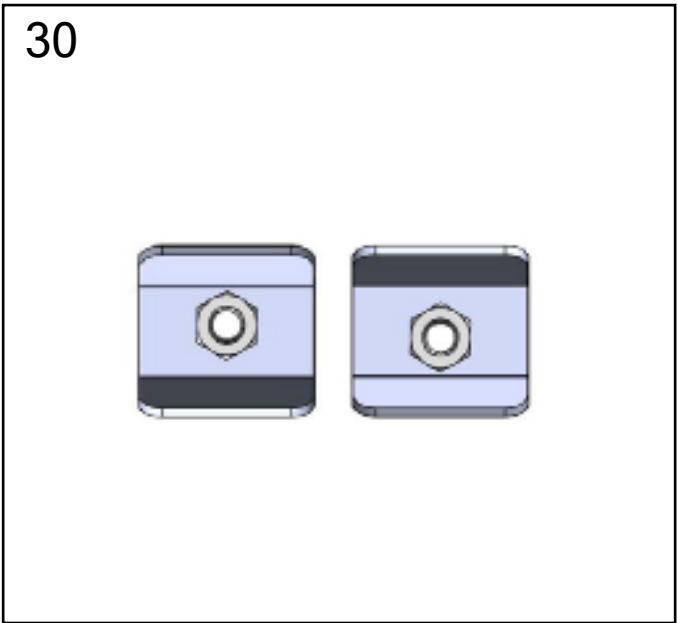

This piece of the **Rub Plate** has two orientations. If the bracket isn't tight enough, flip this piece 180° and tighten.

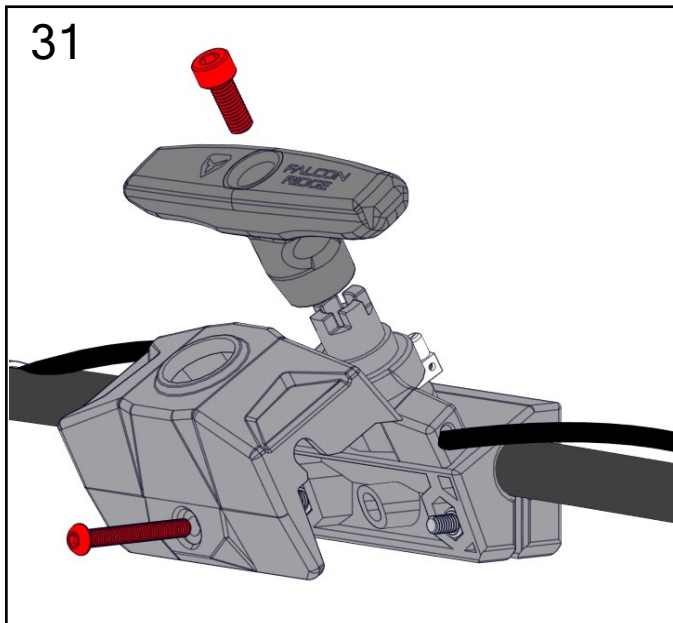

With the windshield still open, remove the **T Handle** with a 6mm allen wrench, and set it aside. Now remove the center M6x45 button head bolt from the **brace mounting block** with a 4mm allen wrench. Put the **brace mounting block cover** over the **brace mounting block** and replace the middle brace mounting block bolt (**M6x45mm button head**) through the hole in the cover and fasten into the captive nut on the back side. Replace the **T Handle** and the **M8x30 socket head bolt** and tighten.

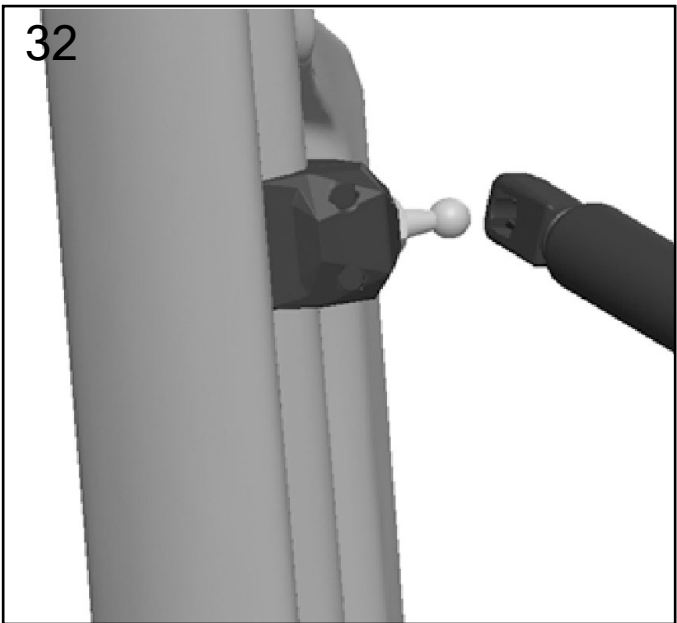

You do not need to remove the clip to do this step Push the head on the larger diameter end of the **Gas Spring** over the ball stud on the **Ball Stud Clamp** until it snaps in place.

33

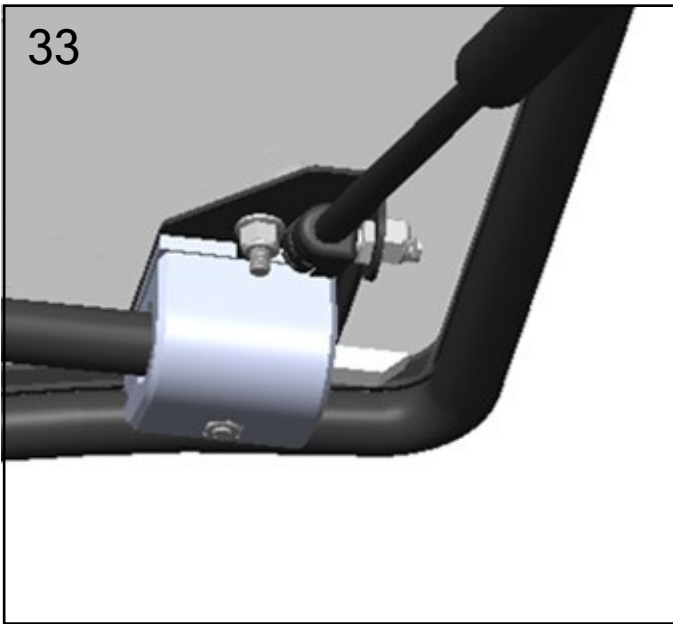

Repeat this process for the smaller diameter end of the **Gas Spring**. Install this end's clip over the ball stud near the **End Mounting Block** on the **Tube Assembly**. Repeat gas spring install for other side of vehicle.

34

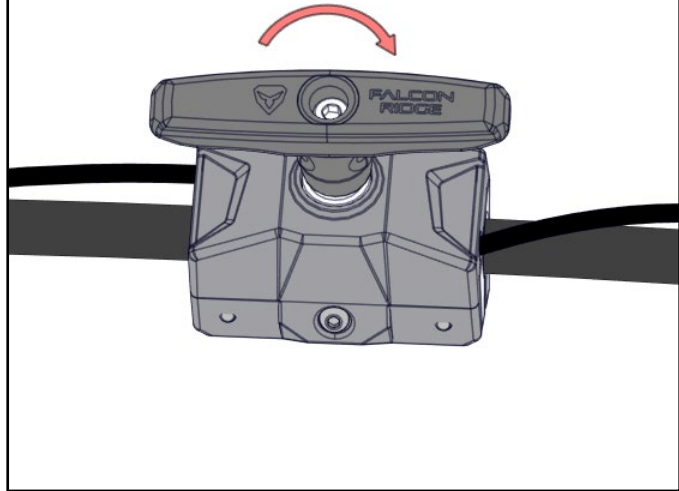

To Close: With the windshield open, pull the **T Handle** swiftly and in a straight line towards you to engage the strikers in the strike plates and close the windshield.

To Open: With the windshield closed, twist the **T Handle** clockwise

Troubleshooting:

Windshield not closing?

- The windshield requires a quick pull to latch, but you should not have to slam the windshield. If it is not closing remove the **T Handle** and **Brace Mounting Block Cover**. Then repeat **step 27** to readjust the cables/striker position.
- Check the clearance of the gasket when closing the windshield. Find any areas where the gasket is getting resistance when trying to close the windshield. If the resistance is on the sides, realign the windshield using **step 24 & 25**. If the resistance is on the bottom of the windshield remove the gas springs by opening the windshield and then removing the gas springs by prying up the retaining ring as in **step 10**. Remove the hinge bolt (**step 24**), remove the **Jam Nut** from **step 19**, and then make sure the rod ends are fully threaded into the **Hinge Half, Upper (steps 20)**. Removing this **Jam Nut** will allow the **Rod End** to thread further into the **Hinge Half, Upper** and therefore raise the windshield. Reassemble the windshield in the original order.

Troubleshooting:

Windshield closing without fully compressing gasket?

- The **Shims** from **step 9** can be removed if the windshield is closing without compressing the **Gasket** enough. Removing these shims will make the **Gasket** compress more when the strikers latch on the **Strike Plates**

Windshield wobbling when closing?

- This is caused by uneven **Ball Stud Clamp** heights or an uneven pulling motion, Re-check the **Ball Stud Clamp** heights from the strike plate bolt as in **step 18**. Pull the windshield with a swift motion aligned with the middle of the vehicle.

Windshield racking?

- If your windshield is crooked, this is a result of the **Rod Ends** being out of alignment. You will need to remove the bolt(s) that connect the **Hing Half, Lower** and the **Hing Half, Upper**. For example, if the top driver's side is low, the **Rod End** needs to be screwed in further, retighten the **Jam Nut** so the **Rod End** stays put. Reinsert the **M8x50 button head bolt** that connects the **Hinge Half, Lower** and the **Hing Half, Upper**. See **Step 23/24** for reference.

