

APE OFFROAD

2515 Bypass Rd. Flemingsburg, KY 41041
606-845-7439

Instructions for Installation and Care of
Can Am Maverick
Aero-Vent Polycarbonate Windshield
CA-MAVERICK -WD05

NOTICE: Please check contents of package for any damage and make sure all parts fit correctly and you are happy with the product before removing protective film. Once the film is removed you cannot return the product for a full refund.

Be sure to read these instructions thoroughly before opening and installing the Can Am Aero-Vent Polycarbonate Windshield.

1. Check over the parts included in the cartons with the parts list shown below:

2" Loom Clamps	4 each
1" Stainless Steels Bolts	11 each
Stainless Steel Washers	15 each
Plastic Thumb Nuts	6 each
Lock Nuts	5 each
Slide Fasteners	8 each
19" Rubber Gasket	1 each
16" Rubber Gasket	2 each
Polycarbonate Brace	1 each
Polycarbonate Vent Sliders	2 each
Polycarbonate Windshield	1 each

If any parts are damaged or missing please contact customer service at (606) 845-7439.

2. Start by pulling it out of the box and find a clean area to lay it down and install the hardware. Begin by peeling off the protective film. Next take the 19" rubber gasket piece and install it in the middle of the windshield. Then take the two 16" pieces in install then on each side. **The windshield below is for reference only and does not represent the Maverick.**

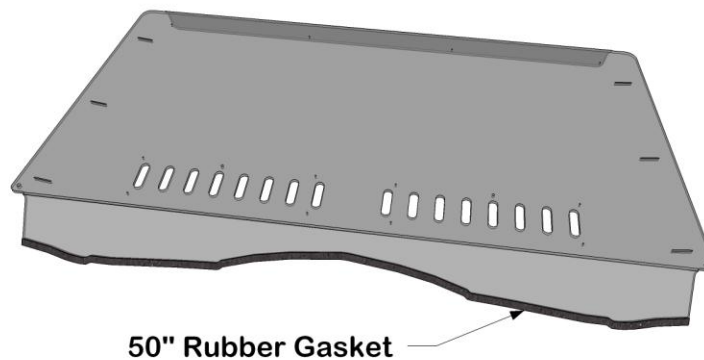

3. Next install the sliding vent panel on the inside of the windshield as shown in the diagram below. To install slide fasteners, push through holes with thumbs until it is completely through the hole in the windshield and locked in place.

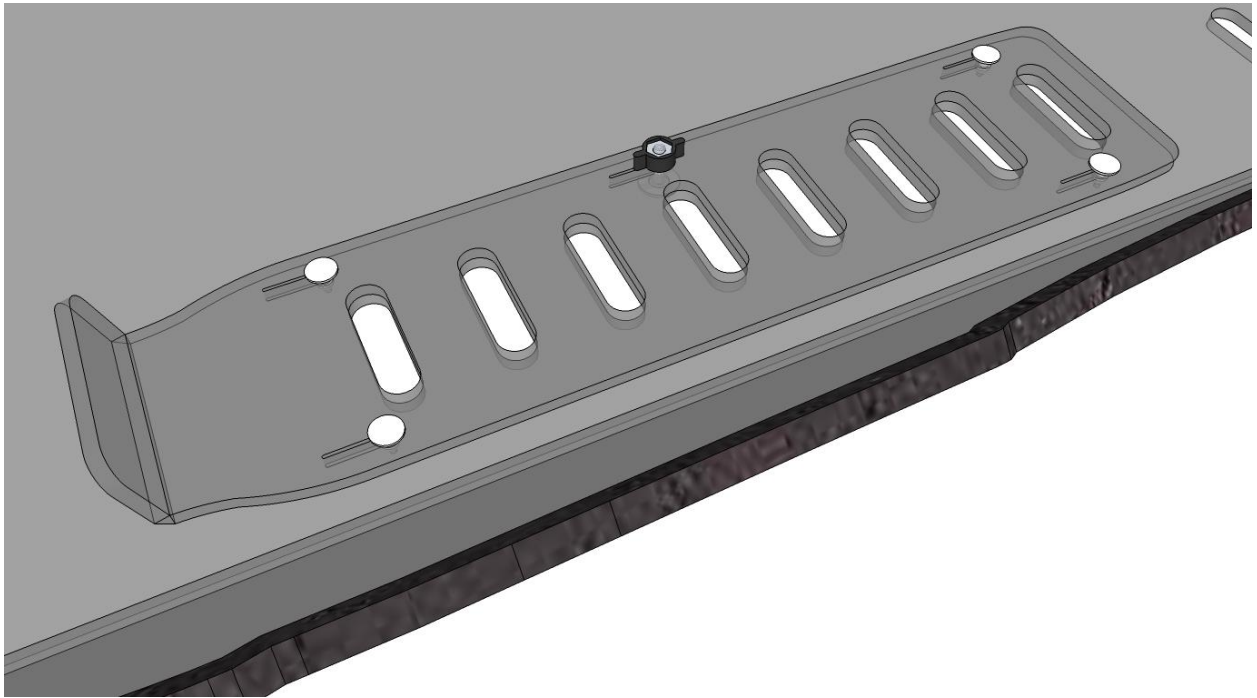
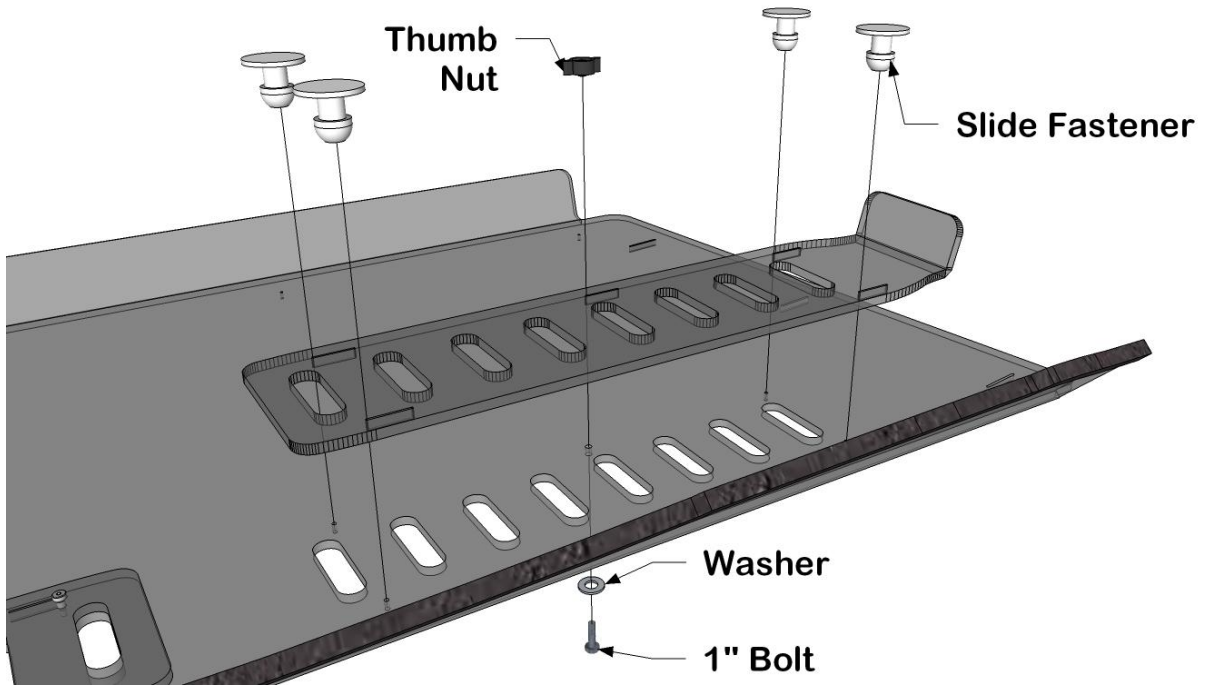

4. Now the Windshield is ready to be installed. With the help of a friend, place the Windshield on the Commander, setting it up onto the hood.
5. Take the remaining hardware and install the windshield to the roll cage as shown in the diagram on the next page.

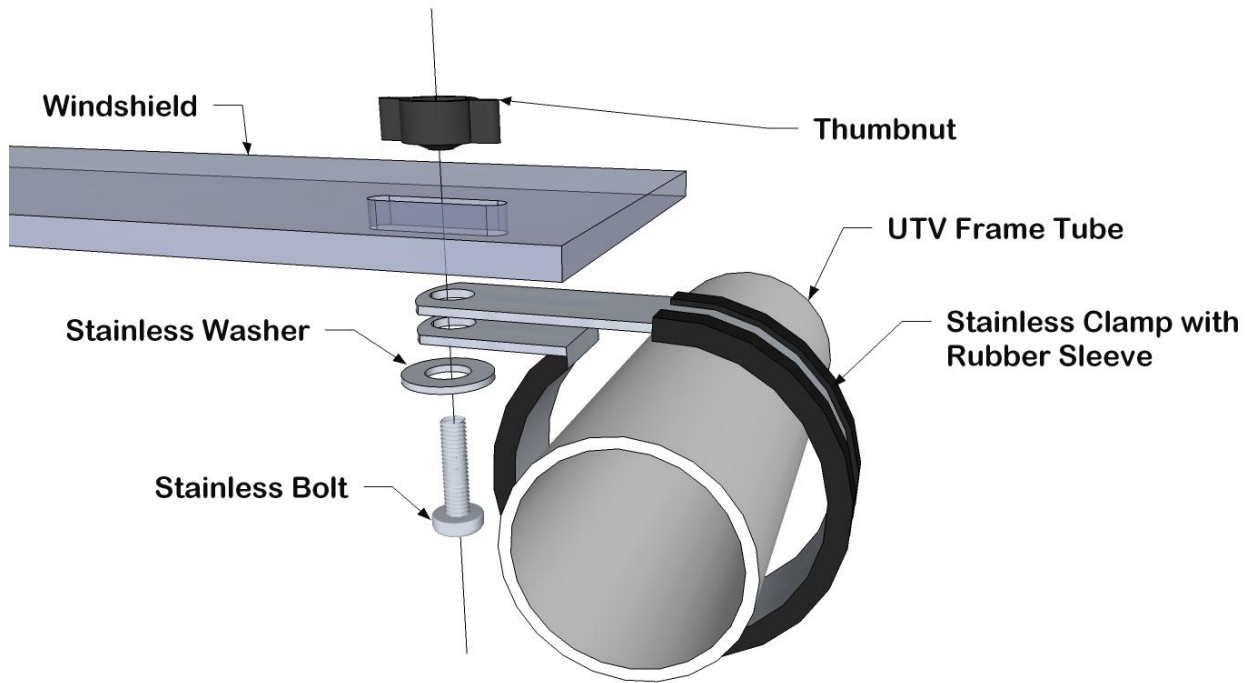

6. Now you can install the top brace if you want. If you do not have an Ape Offroad Cab enclosure to work with this windshield, the top brace is not needed but can be installed for extra strength. Below is a diagram showing how the brace is to be installed.

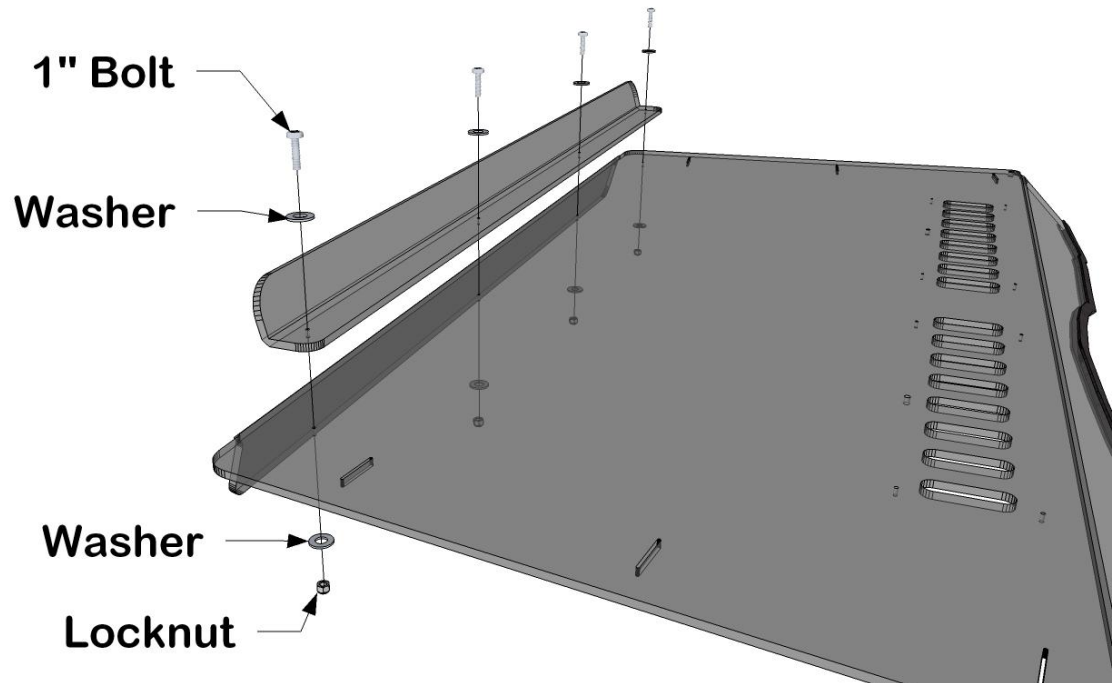

7. If you are using this windshield with an Ape Offroad Cab enclosure, then you will use the Top Brace to sandwich the cab material and seal off the inside from the wind. The diagram below shows how it will work.

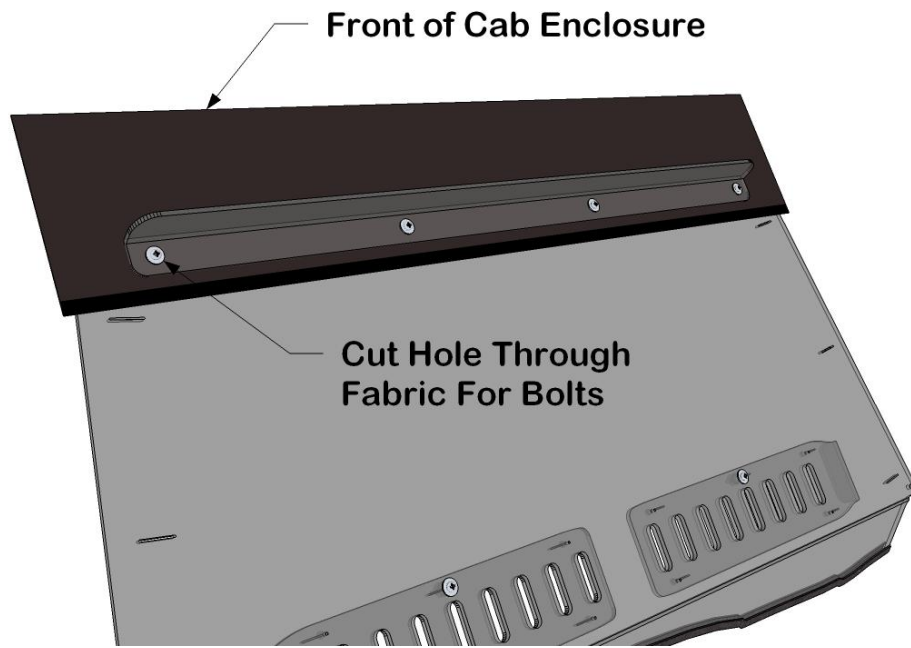

8. Now you are ready to take it out and enjoy. To clean the windshield, always clean using a liquid of some sort to decrease the chance of scratches. We recommend using micro fiber cloths that are readily available at any dollar store. Any window cleaner will work fine; just remember to use a soft clean rag or micro-fiber cloth to clean it.



Completed Windshield – Outside view

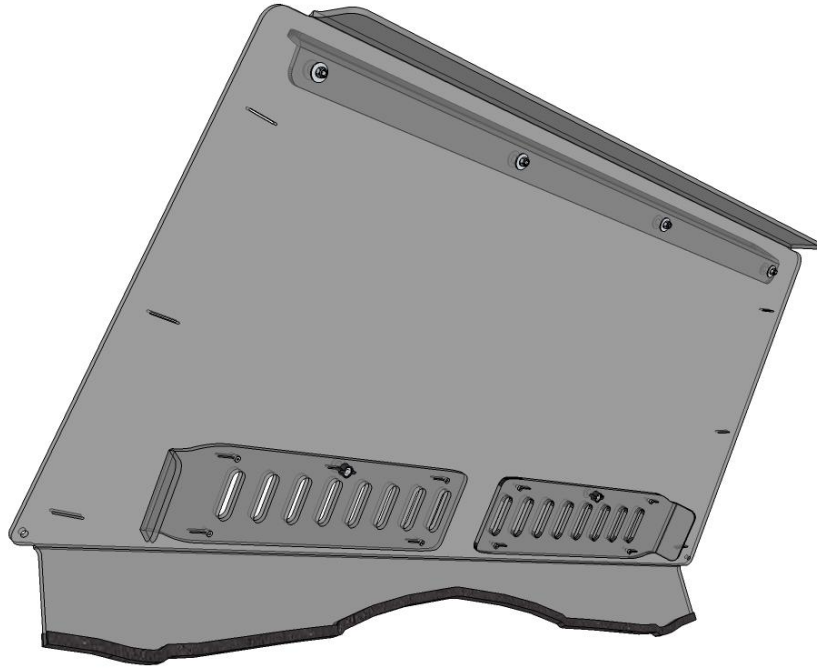

Completed Windshield –Inside view

Thank you for your purchase!

Return Policy

If for any reason you choose to return this product it must be returned within **30 days from date item is received**. You **MUST** package the product exactly **as it was originally packaged from the factory to get a full refund for the product!**

The vinyl windows should never be folded when packaging in the box or for storage purposes. Lay all the windows on top of each other with the canvas folded in between and the paper (if available) on both sides of the windows.

All returned products will be inspected upon arrival at the production facility and must be in unused, factory new condition to receive refund - a 25% restocking fee will apply.

If ordered from Ape Offroad please call at 606-845-7439 to gain a return authorization number, use our preferred shipping carrier (UPS) to return the item (unless the item is defective, you are responsible for paying the shipping to return the item.) **Any returns submitted to Ape Offroad without a return authorization number will be charged a 20% restocking fee.** If ordered from one of Ape Offroad's many distributors', you must first call them and see what their return policy is. Once your item reaches our production facility, our customer satisfaction team will inspect your item to ensure unused, factory new condition. **NOTE: All windshields must be returned with the original protective film intact and not removed. Do NOT REMOVE if you have any intentions of returning the item. Refund/ replacement of a windshield will only be processed on items with original protective film or if the windshield is defective.**

Items must be properly packaged in the original shipping carton to protect them during transit and ensure your returned item arrives back factory fresh, and in new resalable condition (**any returned items that have been used, altered or damaged in any way will not be subject for a refund.**) All contents including instruction manuals, accessories, hardware, Velcro, etc. must be included in your return shipment. Only items in OEM factory new condition will be approved. Once returned items are received, credit will be issued to the original credit card/ payment method used for the purchase. Outbound shipping and return shipping cost will not be refunded. Please allow 4 to 6 weeks for your refund to be processed.

Warranty

To The Owner of this Product:

Thank you for purchasing one of Ape Offroad Cab Enclosures, Tops &/or Windshields! Below are the terms under which your product is covered under our manufacturer's warranty.

30 Day Warranty which includes and is not limited to replacing the enclosure, tops and/or windshield due to defect of the product. Please refer to the return policy in this case for more information.

1 Year Warranty includes any defect in material or workmanship within this time frame we will gladly correct the problem or replace the enclosure, tops &/or windshield. Upon submitting for the correction or replacement we will need to receive pictures of the defect in material or workmanship along with the receipt from the date of purchase.