



**INSTALLATION INSTRUCTIONS
POLARIS RANGER FULL-SIZE 2013
TINTED ROOF
PART # 88-9220-TB**

IMPORTANT NOTICES

READ AND UNDERSTAND THESE INSTRUCTIONS COMPLETELY BEFORE INSTALLATION TO AVOID INJURY TO YOURSELF, DAMAGE TO THE VEHICLE OR ACCESSORY.

- For proper installation, TWO people are required.
- Torque specifications must be followed when tightening bolts. Over-tightening any and/or all screws will cause cracks around mounting holes which is not covered by any warranty.
 - As specified on carton label, once protective film is removed, product cannot be returned.
- As specified on carton label, damage caused by packaging staples is not covered by warranty. All staples must be removed prior to removing product from carton.
- Failure to follow these installation instructions completely may void any warrantable components and result in product damage or personal injury.
- Do not use Loctite or any other similar fastener adhesive. These types of products react to plastics and cause cracking. Not covered by any warranty.
 - Our products are made from the highest quality material providing optimum transparency and clarity. Blurriness and/or extrusion marks may or may not appear when looking through windshield from a wide, side-angle. This is normal for all extruded clear plastic materials.
- The application of improper cleaners, abrasive and/or dirty cleaning towels can severely damage the product. Failure to follow cleaning recommendation (provided herewith) may void any warrantable components.

DEALER

These instructions contain important information for future reference and must be given to the customer at time of purchase or upon completion of installation.

Parts List (parts available with kit only and not available separately)

ITEM	PART NAME	DESCRIPTION	QTY
A	Roof	Roof part made of 1/4" thick GE tinted polycarbonate or equivalent	1
B	Front lip roof part	Roof part made of 1/4" thick GE tinted polycarbonate or equivalent	1
C	Co-extruded bulb seal (1/4")	Includes: 162" Co-extruded bulb seal (1/4") / #77-95BS [end user to cut to exact length]	1
INSTRUCTION BAG	D	Foam cushion Included: 96" of 1" x 1/8" self-adhesive foam cushion [end user to cut to exact length]	1
	E	Nuts & bolts Includes: 4 metal plate hooks, 4 philips truss head screws M6 x 20, 8 philips truss head screws M6 x 24, 17 shoulder washer M6, 3 plastic washers M6, 3 rubber washers M6 and 8 locknuts M6	1
	F	Front bracket hardware Includes: 1 x left support bracket, 1 x right support bracket, 4 Philips truss head screws M6 x 20, 2 Philips truss head screws M6 x 24, 10 plastic washers M6, 2 shoulder washers M6 and 6 locknuts M6	1

1. Installation

- a) Find a clean flat area where you can safely lay down the front lip roof part (Item B). Partially remove the protective film on both sides and apply the co-extruded bulb seal (Item C) to the lower lip using manual pressure to ensure good adhesion to the front lip roof part and cut any excess. **IMPORTANT!** The co-extruded bulb seal **MUST** be fully pressed on to the roof edge or the roof will not fit properly in the roll bar channel.

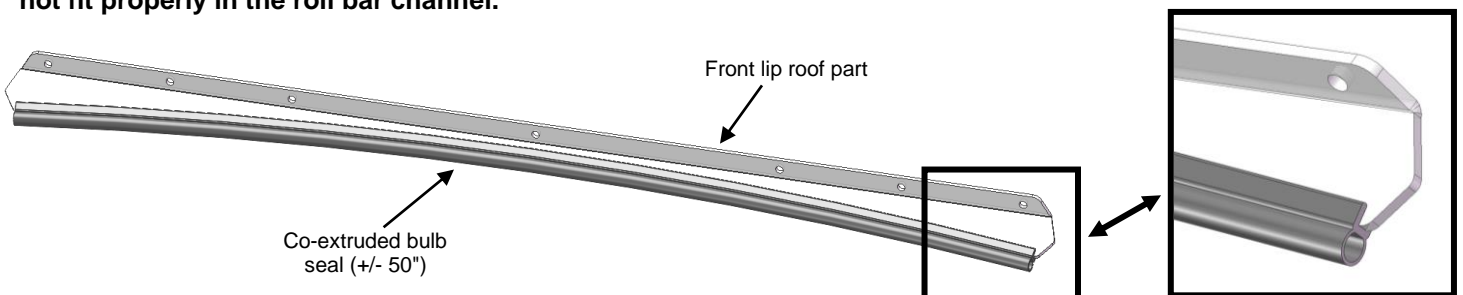

IMPORTANT NOTICES

Torque specifications must be followed when tightening bolts.

Over-tightening any and/or all screws will cause cracks around mounting holes which is not covered by any warranty.

- b) Find a clean flat area where you can safely lay down the roof (Item A) and partially remove protective film from the back side. For proper installation, the roof must be free of any dust or any other contamination. For the front section, precut 2 strips (2 x 21") of self-adhesive foam cushion (Item D) and apply them to the roof as shown below using manual pressure to ensure good adhesion. For the rear section, use the roofs side edge notches as guides to position and align the foam cushion as shown below. You must leave a free gap of 3/4" from side edges.

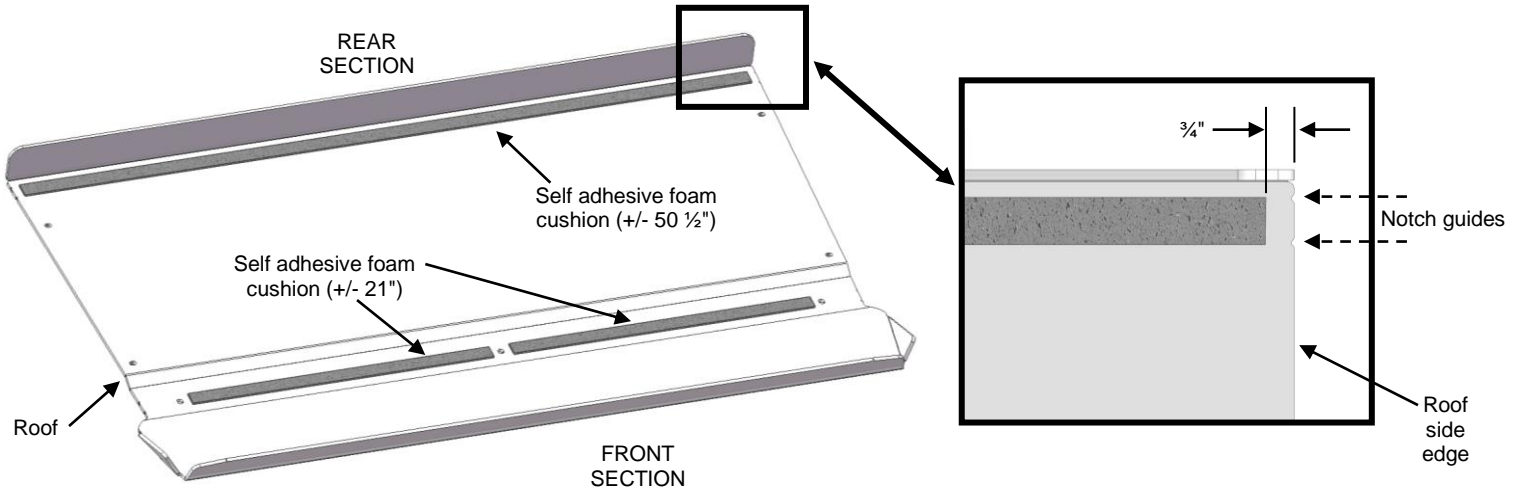

- c) Find a clean flat area where you can safely lay down all the roof parts. Partially remove the protective film on both sides and assemble the roof and the front lip together using supplied hardware (Item E) as shown below.

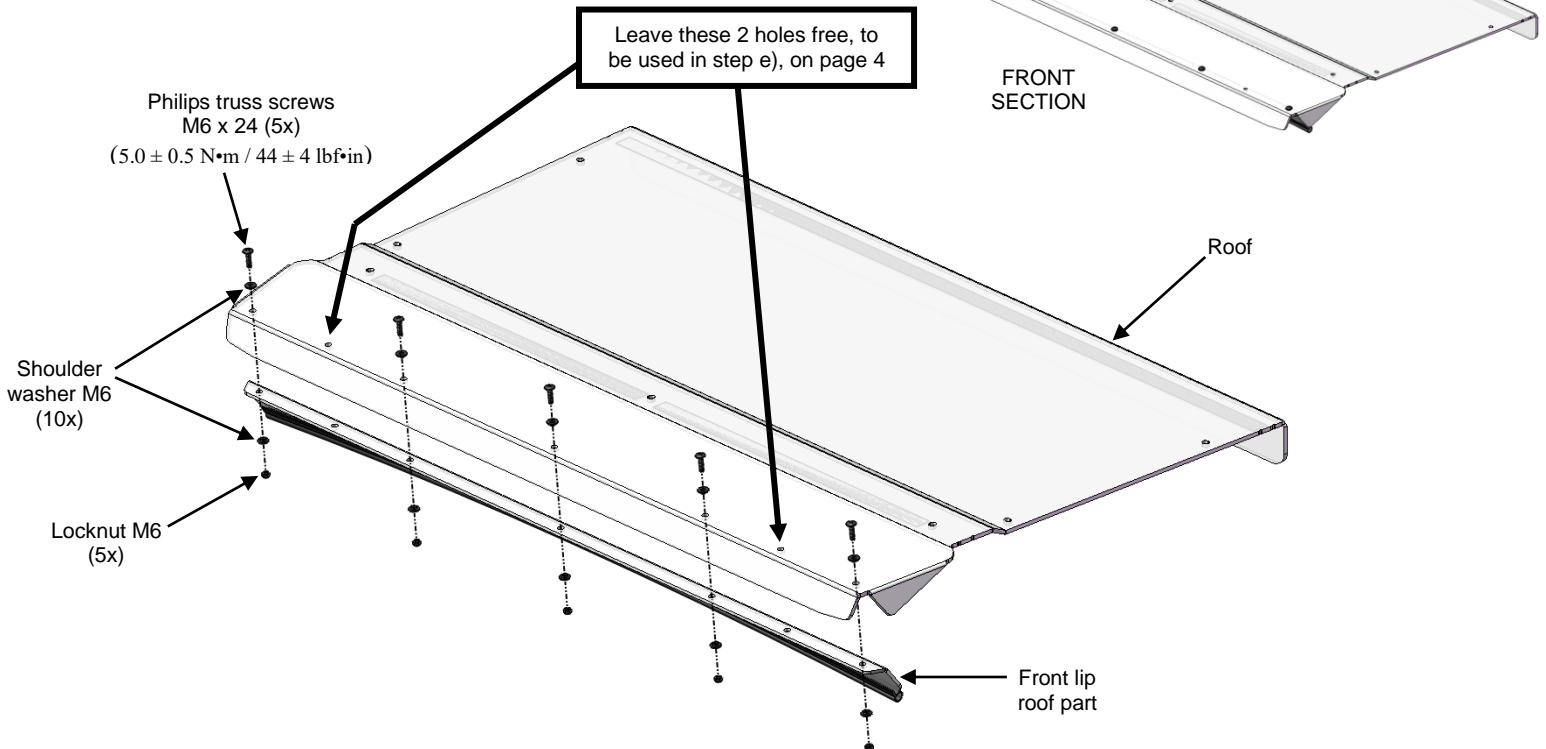

IMPORTANT NOTICES

Torque specifications must be followed when tightening bolts.

Over-tightening any and/or all screws will cause cracks around mounting holes which is not covered by any warranty.

- d) Find a clean flat area where you can safely lay down the assembled roof and partially remove the protective film on both sides to apply the co-extruded bulb seal (Item C) on the roof edges using manual pressure to ensure good adhesion.
IMPORTANT! The co-extruded bulb seal **MUST** be fully pressed on to the roof edge or the roof will not fit properly in the roll bar channel.

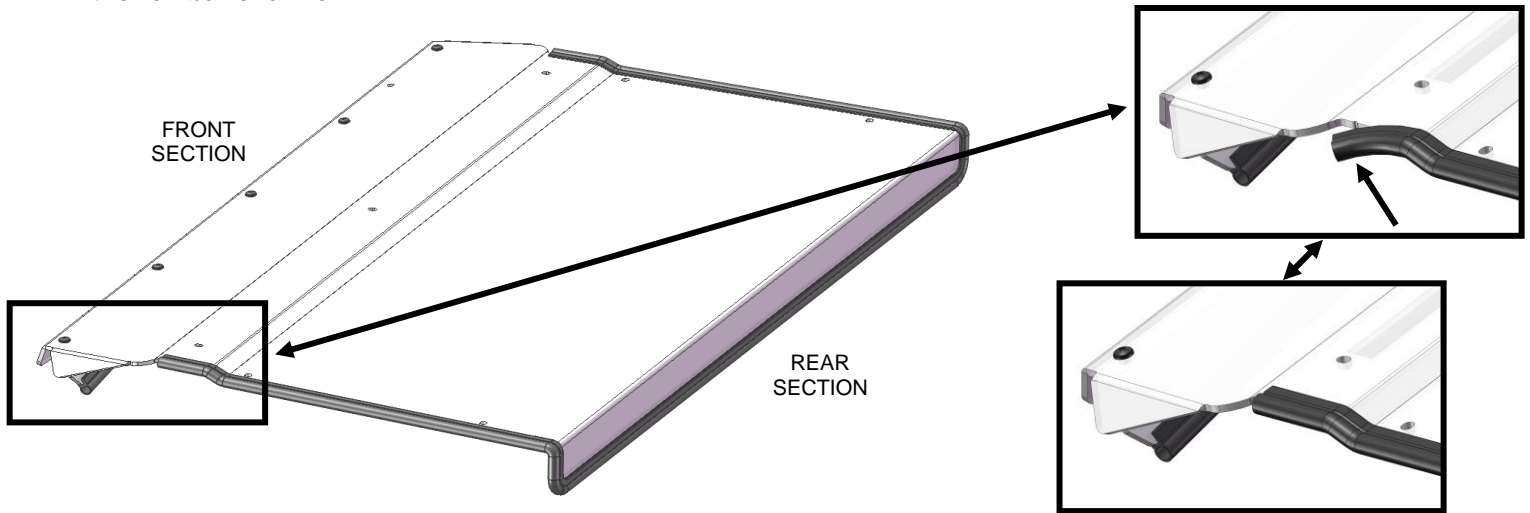

- e) Install the roof to the vehicle using supplied hardware (Item E) as shown below and tighten. Note that some sections of the roll cage are hidden for better clarity.

IMPORTANT! Some extra details on support brackets (Item H) installation are shown on next page.

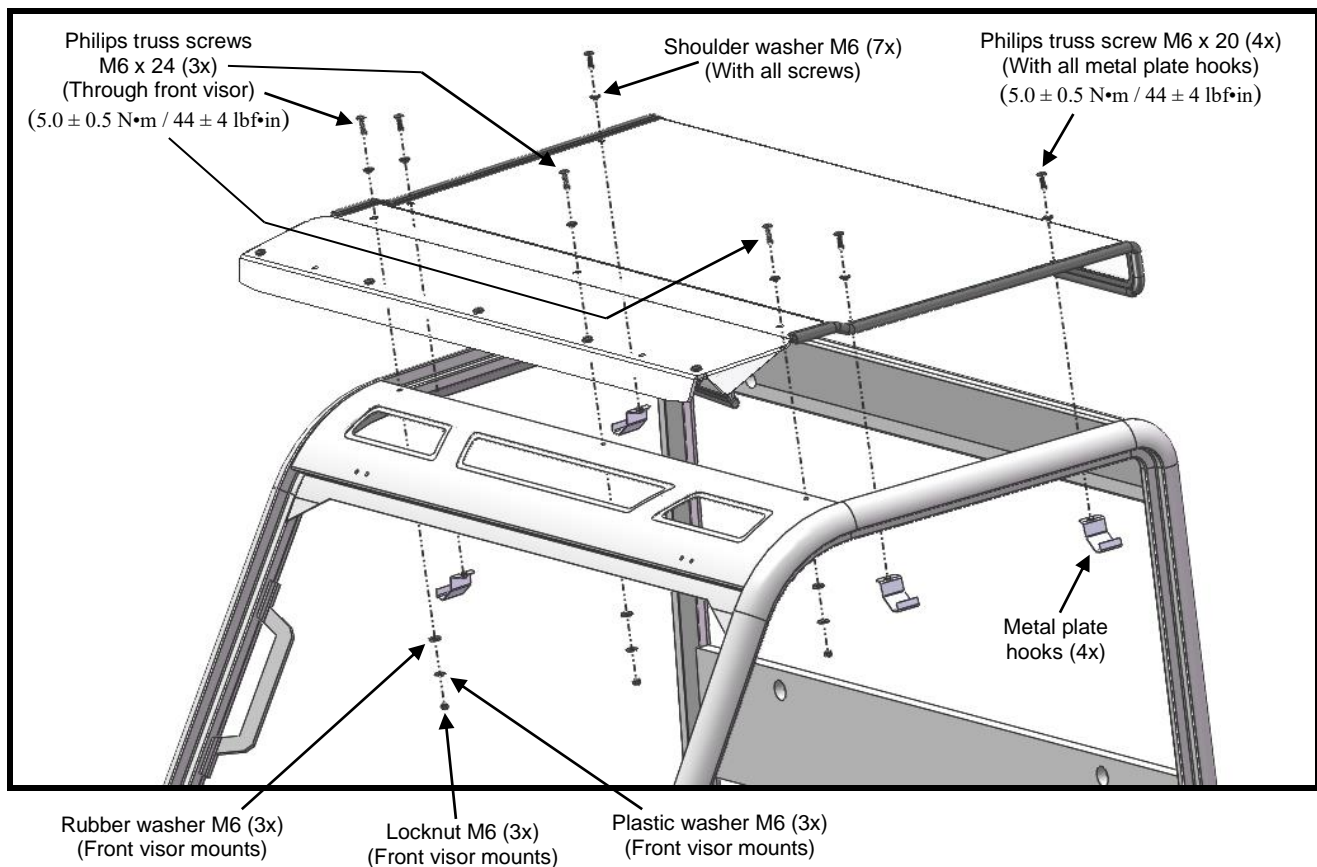

IMPORTANT NOTICES

Torque specifications must be followed when tightening bolts.

Over-tightening any and/or all screws will cause cracks around mounting holes which is not covered by any warranty.

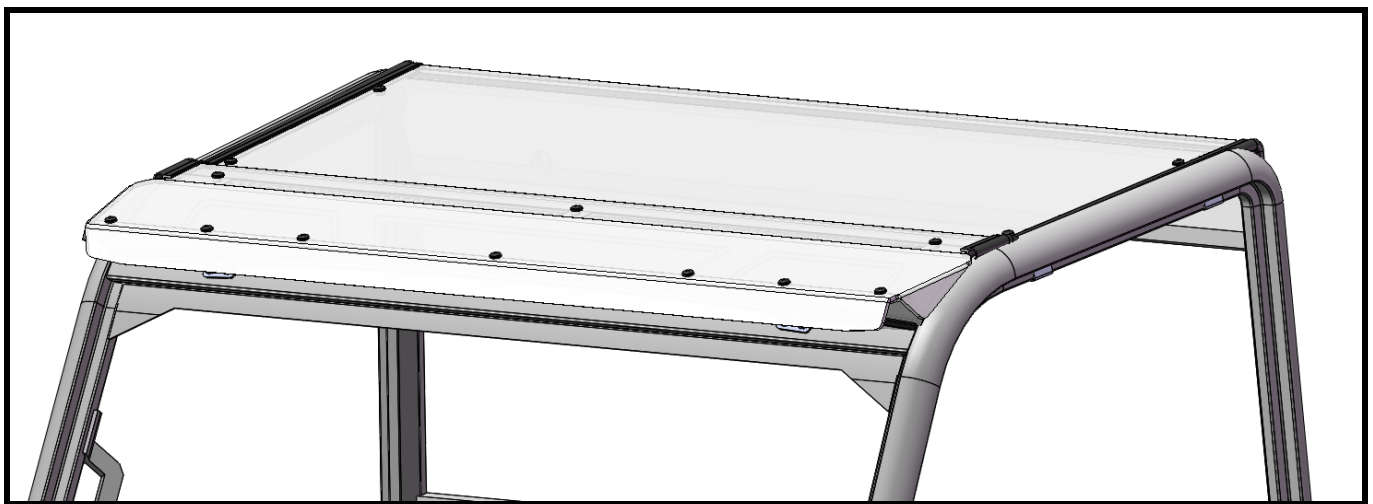
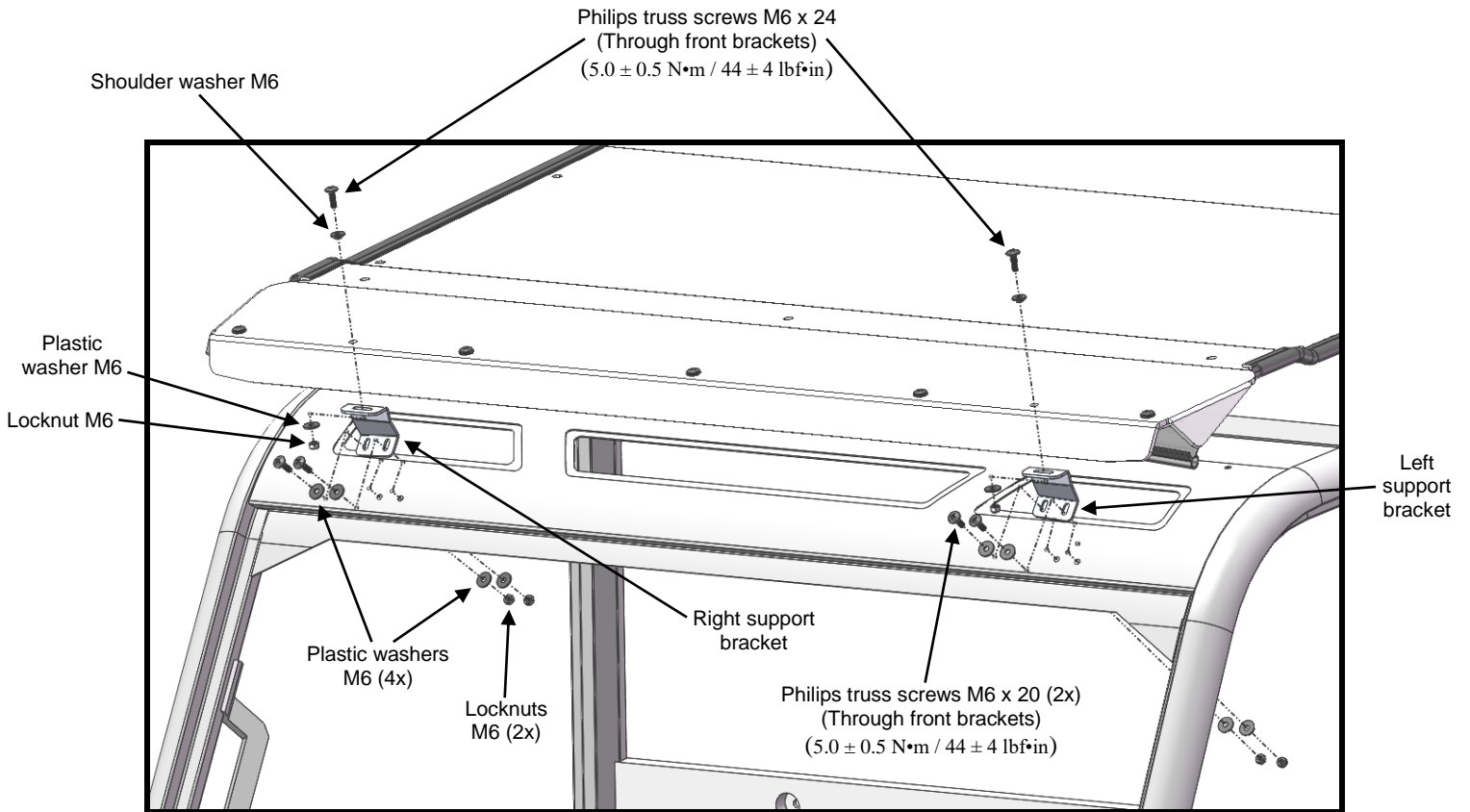

SPECIAL NOTE

If your vehicle is already equipped with a hinged windshield that is using the same mounting holes as the roof support brackets, they can be installed together using roof or windshield hardware as shown in figure II.

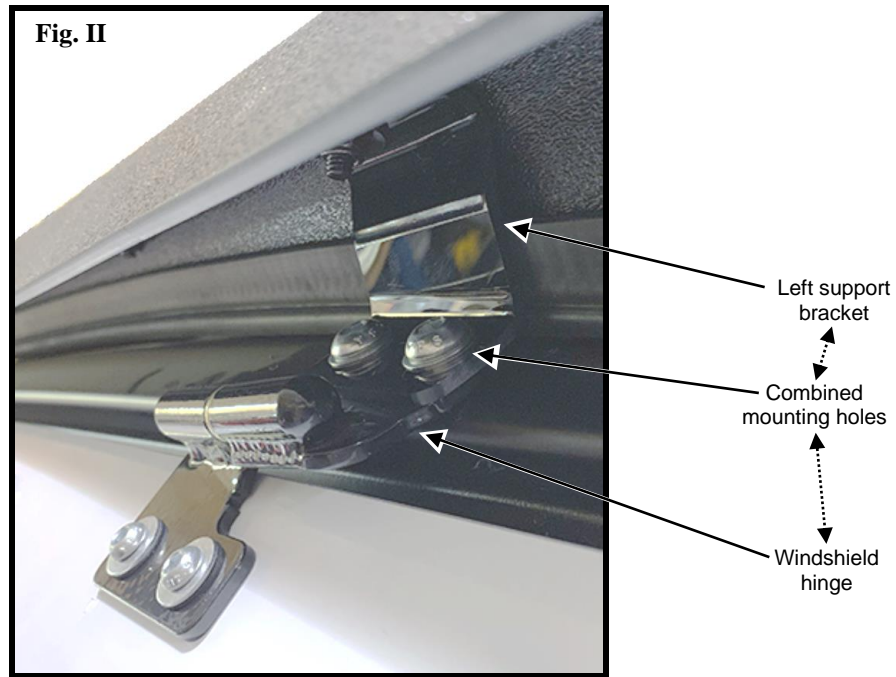

CAUTION

Please understand that open trailer towing can result in windshield/roof damage due to high wind pressure and road debris. Towing at Highway Speeds (75+ mph) for EXTENDED periods (over 100 miles) causes constant and extreme pressure at the mount areas, and is not recommended. Spike suggests removal of roofs/windshields if towed in these conditions-removal will also create less drag on the tow vehicle. Lower speeds (60 mph) or two-lane roads are no problem.

2. Maintenance and Care

Tighten all hardware after first use and periodically thereafter.

CLEANING:

- Rinse with lukewarm water; wash gently with mild soap or detergent and lukewarm water, using a soft cloth or sponge. DO NOT SCRUB or use brushes or squeegees.
 - Rinse again. Dry with soft cloth or moist cellulose sponge to prevent water spotting.
- To remove wet paint, glazing compound or grease, rub lightly with a good grade of VM&P naphtha or isopropyl alcohol, then wash and rinse. DO NOT USE GASOLINE.

NOTICE: Abusive cleaning procedures by hand washing or automated washing equipment will eventually result in visual hazing, loss of light transmission and coating delamination.

Compatible Cleaning Agents

- Aqueous Solution of Soaps and Detergents

-----Joy----- | Freon T.F. | Palmolive liquid | Top Job | VM&P grade Naphtha | Windex (with ammonia D) |

MINIMIZING HAIRLINE SCRATCHES

For minimizing scratches and minor abrasions, mild automobile polish can be used.

Recommended products: Johnson Paste Wax, Novus Plastic Polish #1 and #2, Mirror Glaze plastic polish and Plexux1.

Testing polish on a separate Lexan sample is recommended. Be sure to follow product instructions carefully.