



INSTALLATION INSTRUCTIONS
POLARIS RZR900/1000
LOWER DOOR INSERTS
PART # 55-4200

IMPORTANT NOTICES

READ AND UNDERSTAND THESE INSTRUCTIONS COMPLETELY BEFORE INSTALLATION TO AVOID INJURY TO YOURSELF, DAMAGE TO THE VEHICLE OR ACCESSORY.

- For proper installation, TWO people are required.
- Torque specifications must be followed when tightening bolts. Over-tightening any and/or all screws will cause cracks around mounting holes which is not covered by any warranty.
 - As specified on carton label, once protective film on shields is removed, product cannot be returned.
- As specified on carton label, damage caused by packaging staples is not covered by warranty. All staples must be removed prior to removing product from carton.
- Failure to follow these installation instructions completely may void any warrantable components and result in product damage or personal injury.
- Do not use Loctite or any other similar fastener adhesive. These types of products react to plastics and cause cracking. Not covered by any warranty.
- The application of improper cleaners, abrasive and/or dirty cleaning towels can severely damage the product. Failure to follow cleaning recommendation (provided herewith) may void any warrantable components.

DEALER

These instructions contain important information for future reference and must be given to the customer at time of purchase or upon completion of installation.

Parts List (parts available with kit only and not available separately)

ITEM	PART NAME	DESCRIPTION	QTY
A	Driver side door insert	CNC cut-out made of 1/4" thick GE tinted polycarbonate or equivalent	1
B	Passenger side door insert	CNC cut-out made of 1/4" thick GE tinted polycarbonate or equivalent	1
C	Driver triangle panel (For 900 model)	CNC cut-out made of 1/8" thick high-density polyethylene	1
D	Driver triangle panel (For 1000 model)	CNC cut-out made of 1/8" thick high-density polyethylene	
E	Passenger triangle panel (For 900 model)	CNC cut-out made of 1/8" thick high-density polyethylene	1
F	Passenger triangle panel (For 1000 model)	CNC cut-out made of 1/8" thick high-density polyethylene	
G	Co-extruded bulb seal	Includes: 96" Co-extruded bulb seal [end user to cut to exact length]	1
INSTRUCTION BAG	H	Mounting hardware Includes: 4 phillips truss head screws M6 x 20, 2 plastic washers M6, 4 shoulder washer M6, 2 locknut M6, 6 nylon clamps 1 1/4", 6 button head screws M5 x 16, 12 washers M5, 6 locknuts M5, 2 shoulder washers M8 and 2 locknut M8	1

1. Installation

- a) Partially remove the protective film from both sides and apply the co-extruded side bulb seal (Item G) to the outline edges of the passenger and driver door inserts as shown below using manual pressure to ensure good adhesion and cut any excess.

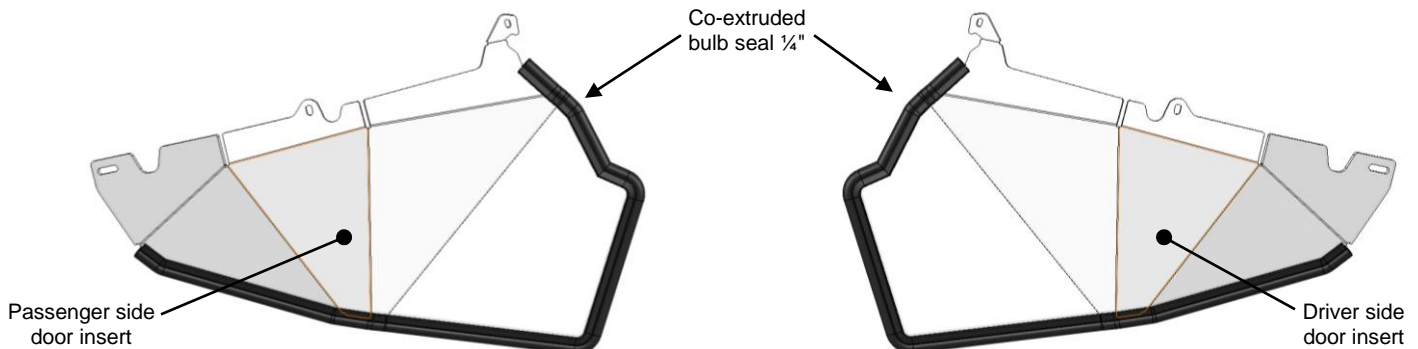

To simplify the installation instructions, only the passenger side will be shown in the following steps. Repeat same procedure for driver side installation

- b)
- Temporarily remove the OEM door skin by removing all 6 OEM Torx screws (6x) as shown below. (to be reused later-on)
 - Temporarily remove the identified OEM hinge mount screw M8 x 20 as shown below. (to be reused later-on)
 - Temporarily remove the identified OEM latch mount screw M6 x 12 as shown below. (to be replaced with supplied hardware)

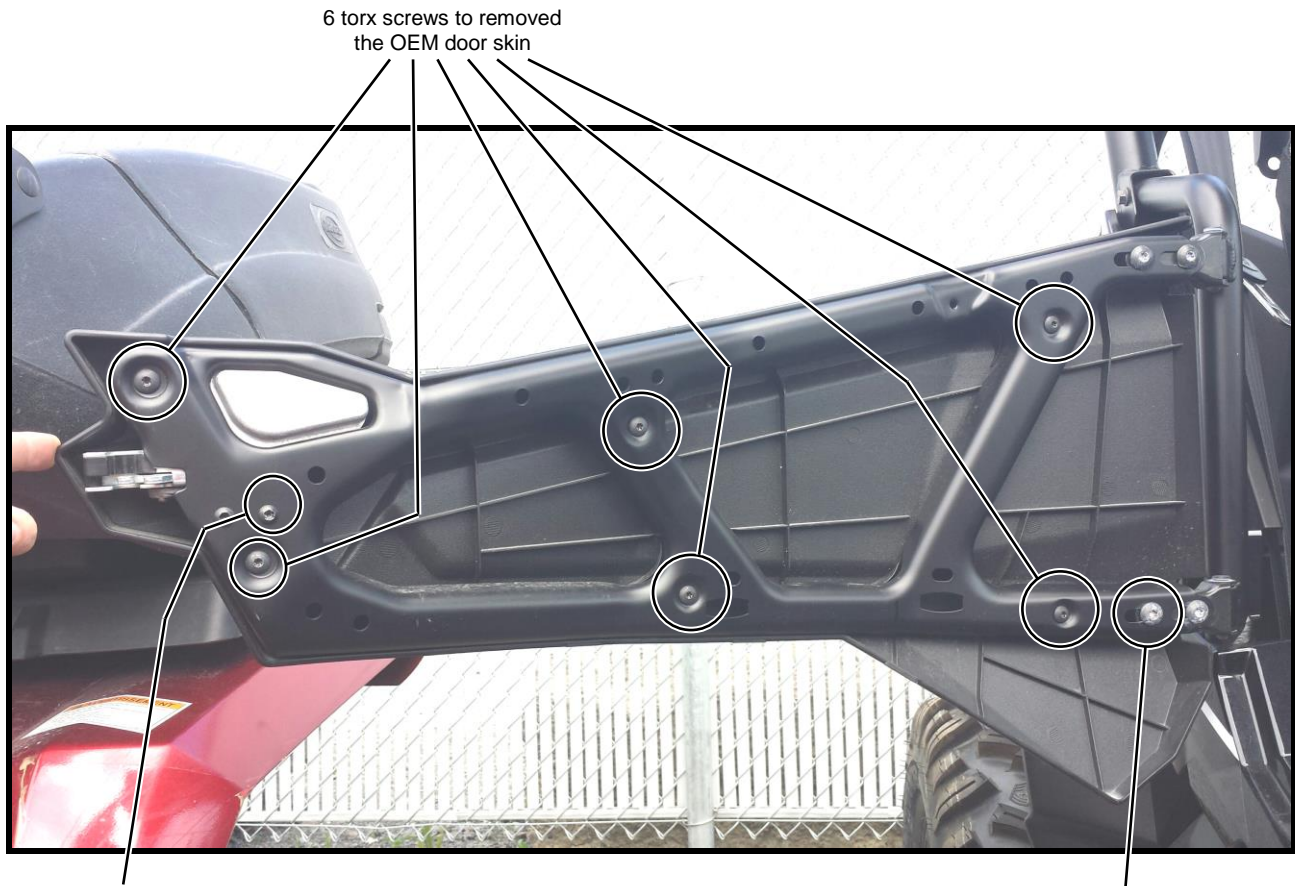

OEM latch mount screw
M6 x 12

OEM hinge mount screw
M8 x 20

IMPORTANT NOTICES

Over-tightening any and/or all screws will cause cracks around mounting holes which is not covered by any warranty.

To simplify the installation instructions, only the passenger side will be shown in the following steps. Repeat same procedure for driver side installation

- c) Attach the door insert to the OEM door frame using supplied and OEM hardware as shown below.as shown.

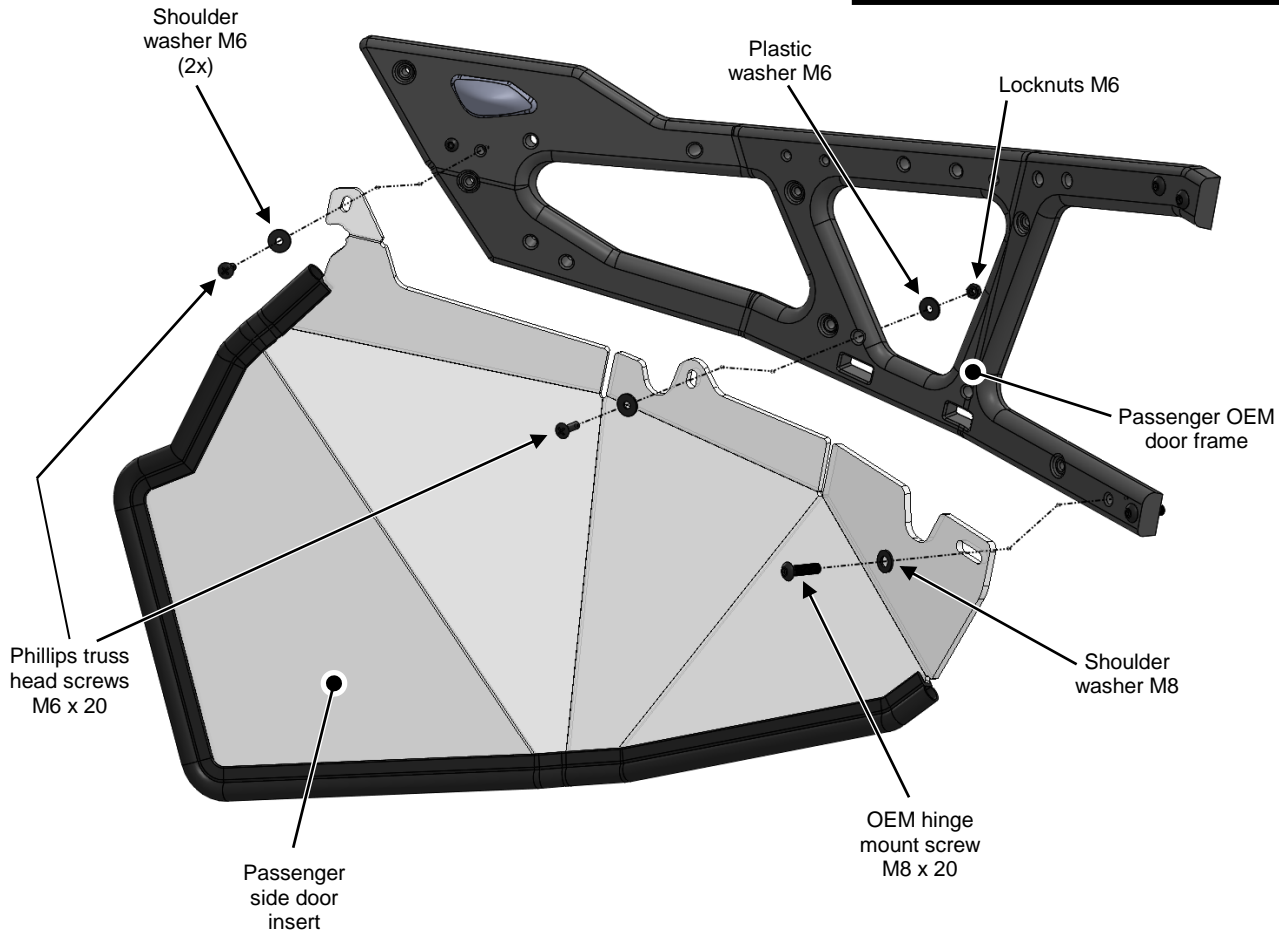

- d) Reinstall the OEM door skin with the 6 original Torx screws removed in step b).

IMPORTANT NOTICES

Over-tightening any and/or all screws will cause cracks around mounting holes which is not covered by any warranty.

To simplify the installation instructions, only the passenger side will be shown in the following steps. Repeat same procedure for driver side installation.

RZR 900 INSTALLATION INSTRUCTIONS SHOWN BELOW. FOR RZR 1000 INSTALLATION INSTRUCTIONS, REFER TO IMAGE & DETAILS "E10A" & "E10B".

- e) Temporarily remove the OEM flange bolt located at the upper section of the door holder support and reinstall together with the triangular panel using supplied hardware as shown below.

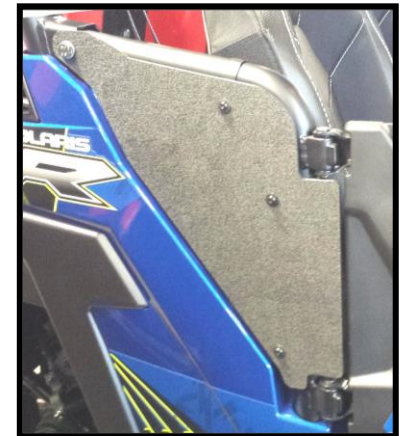
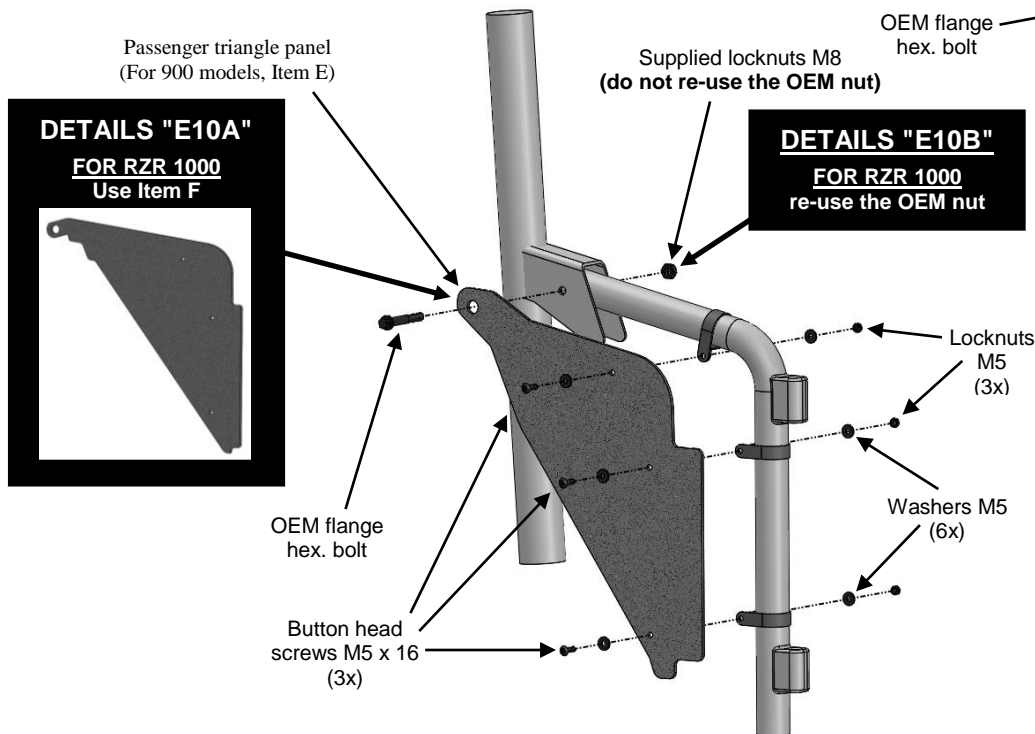

2. Maintenance and Care

Tighten all hardware after first use and periodically thereafter.

CLEANING:

- Rinse with lukewarm water; wash gently with mild soap or detergent and lukewarm water, using a soft cloth or sponge. **DO NOT SCRUB** or use brushes or squeegees.
 - Rinse again. Dry with soft cloth or moist cellulose sponge to prevent water spotting.
- To remove wet paint, glazing compound or grease, rub lightly with a good grade of VM&P naphtha or isopropyl alcohol, then wash and rinse. **DO NOT USE GASOLINE.**

NOTICE: Abusive cleaning procedures by hand washing or automated washing equipment will eventually result in visual hazing, loss of light transmission and coating delamination.

Compatible Cleaning Agents

- Aqueous Solution of Soaps and Detergents

Joy | Freon T.F. | Palmolive liquid | Top Job | VM&P grade Naphtha | Windex (with ammonia D)

MINIMIZING HAIRLINE SCRATCHES

For minimizing scratches and minor abrasions, mild automobile polish can be used.

Recommended products: Johnson Paste Wax, Novus Plastic Polish #1 and #2, Mirror Glaze plastic polish and Plexux1.

Testing polish on a separate Lexan sample is recommended. Be sure to follow product instructions carefully.