

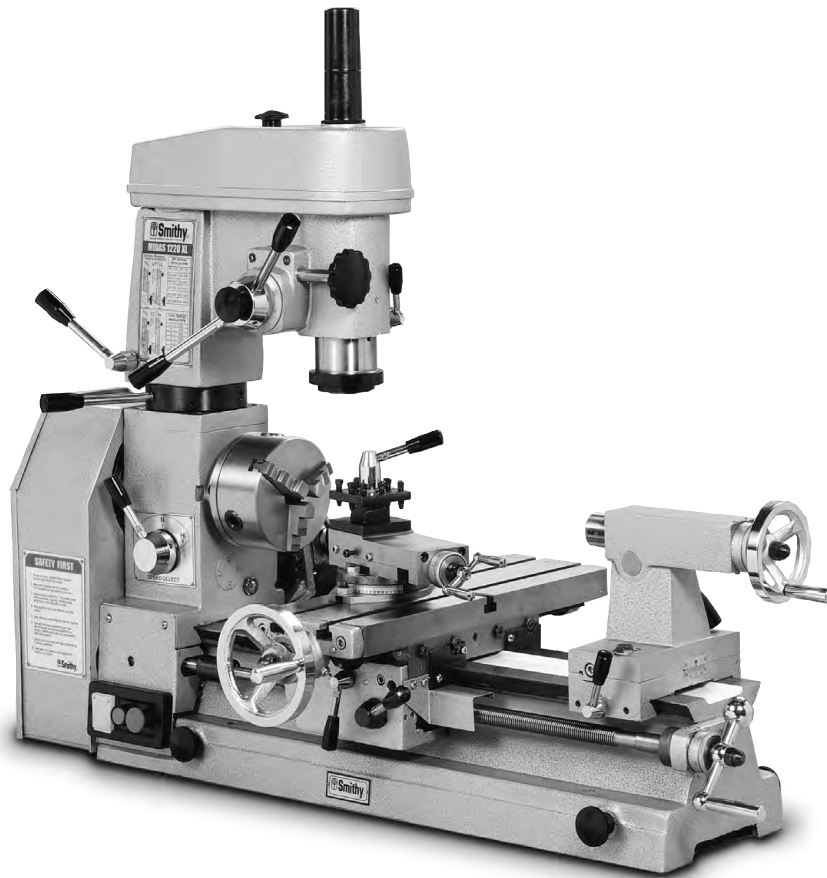

MIDAS 1220 XL COMBINATION LATHE/MILL/DRILL



OPERATOR'S MANUAL

Updated August, 2008

170 April Dr., Ann Arbor, MI, USA 48103

Toll Free 1-800-476-4849

www.smithy.com

© 2008 Smithy Co. All rights reserved (Revision 1).

170 Aprill Dr., Ann Arbor, Michigan, USA 48103
Toll Free Hotline: 1-800-476-4849

Fax: 1-800-431-8892
International: 734-913-6700
International Fax: 734-913-6663

All images shown are from Midas 1220 XL machine.

All rights reserved. No part of this manual may be reproduced or transmitted in any form by any means, electronic, mechanical, photocopying, recording, or otherwise, without prior written permission of Smithy Co. For information on getting permission for reprints and excerpts, comments, or suggestions, contact info@smithy.com

While every precaution has been taken in the preparation of this manual, Smithy Co. shall not have any liability to any person or entity with respect to any loss or damage caused or alleged to be caused directly or indirectly by the instructions contained in this manual. Please see section on warranty and safety precautions before operating the machine.

Printed and bound in the United States of America.

Table of Contents

Inventory Check List	i-iv
Chapter 1: Introduction	1-1
Chapter 2: Safety	2-1
Chapter 3: Knowing Your Machine	3-1
Chapter 4: Caring For Your Machine	4-1
Chapter 5: Basic Parts of the MI-1220 XL	5-1
Chapter 6: Uncrating and Setting Up the MI-1220 XL	
Moving the machine	6-1
Uncrating and Positioning the machine	6-1
Millhead	6-2
Tailstock	6-2
Three Jaw Chuck	6-2
Selecting Location	6-4
Cleaning and Lubricating the MI-1220 LTD	6-4
Oiling the Headstock	6-5
Oiling the Ways	6-5
Oiling the Carriage	6-5
Oiling the Tailstock	6-6
Oiling the Apron	6-6
Oiling the Leadscrew	6-7
Oiling the Compound Angle Toolpost	6-7
Setting Up Your MI-1220 XL	6-8
Setting Lathe and Mill Speeds	6-8
Adjusting Belt Tension	6-9
Adjusting Gibs	6-10
Reducing Backlash	6-11
Crossfeed	6-11
Longfeed	6-12
Running in the MI-1220 XL	6-12
Chapter 7: Turning	
Turning Speeds	7-2
Gear Ratios	7-3

Chapter 8: Metalcutting Theory

Tool Sharpness	8-2
Heat	8-3

Chapter 9: Grinding Cutter Bits for Lathe Tools

High Speed Steel Cutters	9-1
Materials Other than Steel	9-3
Bits for Turning and Machining Brass	9-4
Special Chip Craters and Chipbreakers	9-4
Using a Center Gauge to Check V-Thread Forms	9-4
Acme or Other Special Threads	9-5
Carbide-Tipped Cutters and Cutter Forms	9-5

Chapter 10: Setting Up Lathe Tools

Cutting Tool Height	10-1
Turning Tools	10-1
Threading Tools	10-2
Cutoff, Thread Cutting and Facing Tools	10-3
Boring and Inside Threading Tools	10-3

Chapter 11: Setting Up with Centers, Collets and Chucks

Centering	11-1
Centering a Round and Rectangular Steels	11-2
Mounting Work between Centers	11-4
Using a Clamp Dog	11-4
Setting Up Work on Mandrel	11-6
Steady Rest and Follow Rest	11-6
Setting Up Work in a Chuck	11-8
Mounting Work in a Four-Jaw Independent Lathe Chuck	11-8
Mounting Work in a Three-Jaw Universal Chuck	11-10
Collet and Collet Attachments	11-11
Toolpost Grinders	11-12

Chapter 12: Lathe Turning

Rough Turning	12-1
Finish Turning	12-2
Turning to Shapes	12-2
Machining Square Corners	12-3
Taper Turning	12-4
Boring a Tapered Hole	12-6

Chapter 13: Lathe Facing and Knurling

Facing Across the Clutch	13-1
Knurling	13-2

Chapter 14: Changing Gears14-1

Chapter 15: Cutting Screw Threads

Threading Terms	15-1
Cutting Right Hand Threads	15-3
Cutting Left Hand Threads	15-4
Cutting Multiple Threads	15-4
What Not To Do When Cutting Threads	15-5
Finishing Off a Threaded End	15-5
Cutting Threads on a Taper	15-5

Chapter 16: Lathe Drilling and Boring

Reaming	16-1
Boring	16-2
Cutting Internal Threads	16-4
Cutting Special Form Internal Threads	16-5

Chapter 17: Cutting Off or Parting with a Lathe17-1

Chapter 18: Milling18-1

Chapter 19: Workholding

Mounting to the Table	19-1
Using a Vise	19-1
Dividing Heads	19-2
Rotary Tables	19-2

Chapter 20: Holding Milling Cutters

Arbors	20-1
Collets and Holders	20-1
Adaptors	20-2

Chapter 21: Milling Cutters

End Mill Cutters	21-1
Plain Milling Cutters	21-3
Side Milling Cutters	21-3

Slitting Saws21-4
Angle Milling Cutters21-4
Form Relieved Cutters21-4
Flycutters21-4
Using Cutting Fluid21-5
Tool Grinding21-6

Chapter 22: Speeds and Feeds for Milling

Feeds22-1
Up Milling22-1

Chapter 23: Common Milling Operations

Milling Flat Surfaces23-1
Squaring a Workpiece23-2
Milling a Cavity23-2
Tapping23-2

Chapter 24: Common Adjustments

Bevel Gear Adjustment24-1
Millhead T-Key24-2

Chapter 25: Troubleshooting

Powerfeed and Thread Cutting25-1
Carriage and Milling Table25-2
Lathe Turning25-3
Milling25-4
Drilling25-5
Drive System25-6

Chapter 26: MI-1220 XL Full Specifications26-1

Chapter 27: Removing the Apron from the MI-1220 XL 27-1

Chapter 22: Changing the Lateral Drive Shaft in the MI-1220 XL Apron28-1

Inventory Check List

It is a good idea to take inventory of the parts of your machine soon after it is unpacked. By doing so, you can quickly determine if any parts are missing. In addition, should you find it necessary to return the machine to Smithy for any reason, the inventory will ensure that all the parts you received have been returned. It is also good to take a look at the inventory before you operate the machine so that you can be familiar with the names of all the parts of your Smithy machine.



Allen Wrench, 4mm
Item #: C30540
Quantity 1

Allen Wrench, 5mm
Item #: C30542
Quantity 1

Allen Wrench, 6mm
Item #: C30537
Quantity 1

Allen Wrench, 8mm
Item #: C30536
Quantity 1

Wrench, 14 mm
Item #: 81-500
Quantity 1



Arbor, JT33-MT3
(No Tang)
Item #: C30523
Quantity 1

Drift, MT2
Item #: C30558
Quantity 1

Dead Center, MT3
Item #: 41-003
Quantity 1



Dead Center, MT4
Item #: 41-004
Quantity 1



Drill chuck, 1/2"
Item #: 72-001
Quantity 1



Gear, 32 Teeth
Item #: C30145
Quantity 2

Gear, 33 Teeth
Item #: C30146
Quantity 1

Gear, 39 Teeth
Item #: C30148
Quantity 1

Gear, 40 Teeth
Item #: C30149
Quantity 1

Gear, 42 Teeth
Item #: C30150
Quantity 1

Gear, 45 Teeth
Item #: C30156
Quantity 1

Gear, 48 Teeth
Item #: C30151
Quantity 1

Gear, 49 Teeth
Item #: C30152
Quantity 1

Gear, 50 Teeth
Item #: C30153
Quantity 1

Gear, 56 Teeth
Item #: C30157
Quantity 1

Gear, 60 Teeth
Item #: C30159
Quantity 1

Gear, 70 Teeth
Item #: C30202
Quantity 1

Gears on the machine:

Gear, 27 Teeth
Item #: C30143
Quantity 2

Gear, 30 Teeth
Item #: C30144
Quantity 1

Gear, 60 Teeth
Item #: C30159
Quantity 1

Gear, 63 Teeth
Item #: C30160
Quantity 1

Jaws (3), 5"
Item #: 9-10
Quantity 1 set of 3



Key, Lathe Chuck
Item #: C30532
Quantity 1



Key, Drill Chuck
Item #: C30533
Quantity 1



Open End Wrench,
8/10mm
Item #: C30539
Quantity 1



Open End Wrench,
17/19mm
Item #: C30535
Quantity 1



Adapter Precision
End Mill
Item #: 65-010
Quantity 1



End Mill Single
4 FHSS 3/8 1/4"
Item #: 50-402
Quantity 1

End Mill Single
4 FHSS 3/8 3/8"
Item #: 50-406
Quantity 1

End Mill Single
4 FHSS 3/8 1/4"
Item #: 50-410
Quantity 1

T-Slot Nut, 7/16"
Item #: 35-105
Quantity 2



Washer,
Anti-Back Lash Shim
Item #: 82-050
Quantity 3

Vise, Bracket Bolt
3/8 x 1-1/4"
Item #: 36-610
Quantity 2

Plug, Drill Chuck Arbor
Item #: S12898
Quantity 1



Air Mask
Item #: 15-020
Quantity 1

Goggles
Item #: 15-015
Quantity 1

Ear Plug
Item #: 15-025
Quantity 1

Drawbar,
3/8 x 16 x 14"
Item #: 75-A
Quantity 1



Nut, 3/8 16
Item #: 7-6
Quantity 1

Washer,
Flat 5/16"
Item #: 7-8
Quantity 1



Vise, 0-90 Degrees
Adjustable Angle 3-1/4" Jaw
Item #: 32-110
Quantity 1

Carbide Bit Set
Item #: 43-000
Quantity 1



Machine Tool
Basics (DVD)
Item #: 12-004
Quantity 1



Cutting Fluid/ Tapping
Item #: 49-101
Quantity 1



- Operator's Manual
Item #: 83-949
Quantity 1



- Manual Cover
Item #: 83-942
Quantity 1

- Oil Can
Part # 80-100
Quantity 1



- 5" 3 Jaw Chuck
Part # C30532
Quantity 1



- Compound Angle Toolpost
Part # 45-110
Quantity 1



Missing Items?

If you find that an item is missing or defective from your Quick Start Tool Pack

**Call Us TOLL FREE 1-800-476-4849
or send an e-mail to info@smithy.com**

within 30 days of receiving your machine so that we may assist you immediately.
Our sales and service technicians are available 8am to 5pm ET, Mondays to Fridays.

Chapter 1

Introduction

Congratulations on purchasing a Smithy Midas 1220 XL lathe-mill-drill. We are pleased you chose Smithy to fulfil your machining needs.

The purpose of this manual is to give the machinist, beginner or advanced, the information he needs to operate the Smithy Midas 1220 XL. It will teach you about the machine's parts and how to care for them. In fact, education is our primary goal. We'll explain how to grind cutters, set up lathe tools, hold workpieces, and do all basic machining operations.

Please read this operator's manual carefully. If you don't understand how your machine works, you may damage it, your project, or yourself. If you want to learn more about machining practices, Smithy offers books that meet the needs of machinists at all level of experience. We also suggest using your local library as a resource. Enrolling in a machining class will give you the best knowledge of machining.

If you have any questions not covered in this operator's manual, please call Smithy Co. Our trained technicians will help you with any machining problems you may have. You can reach them by dialing 1-800-476-4849 Monday through Friday, 8:00 am to 5:00 pm Eastern time.

We are always interested in your suggestions to improve our products and services. Feel free to contact us by phone or in writing. If you have comments about this operator's manual, or if you have a project you'd like to share with other Smithy owners, contact the Communications Director, Smithy Co., PO Box 1517, Ann Arbor, MI48106-1517.

We look forward to a long working relationship with you. And thank you again for putting your trust in Smithy.

Customer Information

This manual should remain with your Smithy machine. If ownership changes, please include the owner's manual with the machine.

<p>Model # _____ Serial # _____ (on the back of the lathe bed)</p> <p>Purchase date _____ Delivery date _____ Sales Technician _____</p>
--

Chapter 2

Safety

Your workshop is only as safe as you make it. Take responsibility for the safety of all who use or visit it. This list of rules is by no means complete, and remembers that common sense is a must.

- 1.** Know your machine. Read this manual thoroughly before attempting to operate your lathe-mill-drill. Don't try to do more than you or your machine can handle. Understand the hazards of operating a machine tool. In particular, remember never to change speeds or setups until the machine is completely stopped, and never to operate it without first rolling up your sleeves or tying them at your wrists.
- 2.** Ground the machine. The Midas 1220 XL has a three conductor cord and a three pronged grounding type receptacle. Never connect the power supply without properly grounding the machine.
- 3.** Remove all adjusting keys and wrenches from the machine before operating. A chuck key or misplaced Allen wrench can be a safety hazard.
- 4.** Keep your work area clean and organized. Cluttered work areas and benches invite accidents. Have a place for everything and put everything in its place.
- 5.** Keep children away from the machine while it is in use. Childproof your shop with padlocks, master switches, and starter keys, or store the machine where children do not have access to it.
- 6.** Wear appropriate clothing. Avoid loose fitting clothes, gloves, neckties, or jewellery that could get caught in moving parts. If you have long hair, tie it up or otherwise keep it out of the machine.
- 7.** Use safety glasses, goggles, or a face shield at all times. Use glasses designed for machinery operation; regular glasses will not do. Have extras for visitors. Know when to wear a face mask and earplugs, as well.
- 8.** Check for damaged parts. Make sure the machine will run properly before operating it.
- 9.** Disconnect the machine before servicing and when changing accessories. Shut power off before making changes, removing debris, or measuring your work. Don't reach over the machine when it's operating. Keep you hands out of the way.
- 10.** Avoid accidental starts. Turn the switch to Off before plugging in the machine.
- 11.** Secure your work. Flying metal is dangerous. Loose work can also bind tools.
- 12.** Use the recommended accessories. Understand how to use them before trying them out.

13. Use the correct tool for the job. Don't try to make a tool into something it isn't.

14. Keep your mind on your work.

Pay attention to these simple rules and you will spend many safe, enjoyable hours in your workshop.

Remember: Your safety largely on your practices. Modifying your machine may void the warranty and create potential hazards.

Chapter 3

Knowing Your Machine

The Midas 1220 XL has a 3/4 hp, 110 V motor. The motor powers the lathe and millhead through the main belt drive and the mill/drill belt drive.

A positive lock clutch in front of the spindle pulley transfers power to either the lathe or the mill. The clutch has three positions. To power the lathe, pull the clutch handle out. To power the mill, push the clutch all the way in. The middle position is neutral. Always shift the clutch with the motor turned off.

The Smithy can use V-belts or round polyurethane belts. The latter produce less dust and is easier to change than standard V-belts.

The lathe runs at six speeds from 160 to 1600 rpm. To change lathe speeds, adjust the belts in the main belt-drive system. This system uses three pulleys: the motor pulley, floating idler pulley and spindle pulley.

To run the lathe at lower turning speeds, use two belts. Install one between the motor and idler pulleys and the other between the idler and spindle pulleys. To increase the speed, move the spindle belt in two more positions on the pulleys.

For higher ranges, use one long belt from the motor pulley directly to the spindle pulley. You can adjust this belt to three different positions on the pulleys.

The millhead also has a belt-drive system. It uses only one belt, adjustable to either the top or bottom position on the pulleys. These two positions, in conjunction with the main belt drive, let you select 12 speeds ranging from 125 to 1600 rpm for milling or drilling.

Chapter 4

Caring For Your Machine

The Midas 1220 XL is a delicate, precision tool with ground ways and hand-scraped bearing surfaces under the table and carriage. Any rust spot or battering of the ways, any chips or grit between close fitting parts, will affect the accuracy of this fine tool. Follow these guidelines whenever you use your Smithy machine.

When you finish working, wipe machined surfaces with a clean, oily rag. Never leave the machine without this thin film of protective oil over all parts that might rust, especially ground finished parts.

Never lay wrenches, cutting tools, files, or other tools across the ways of your lathe. The slightest dent or burr could impair its accuracy.

Before inserting collars, centers, adapters, or drawbar attachments in either the spindle or tailstock spindle, wipe them with a clean, oily rag. Also wipe all internal surfaces carefully with an oily rag on a ramrod. Chips or dirt on the centers or in the spindle nose can scratch or mar surfaces and interfere with the assembled part's alignment.

Lubricate the machine before each use (see Section 6.4)

Chapter 5

Basic Parts of the MI-1220 XL

To learn the operations of your machine, you have to know the names and functions of its basic parts.

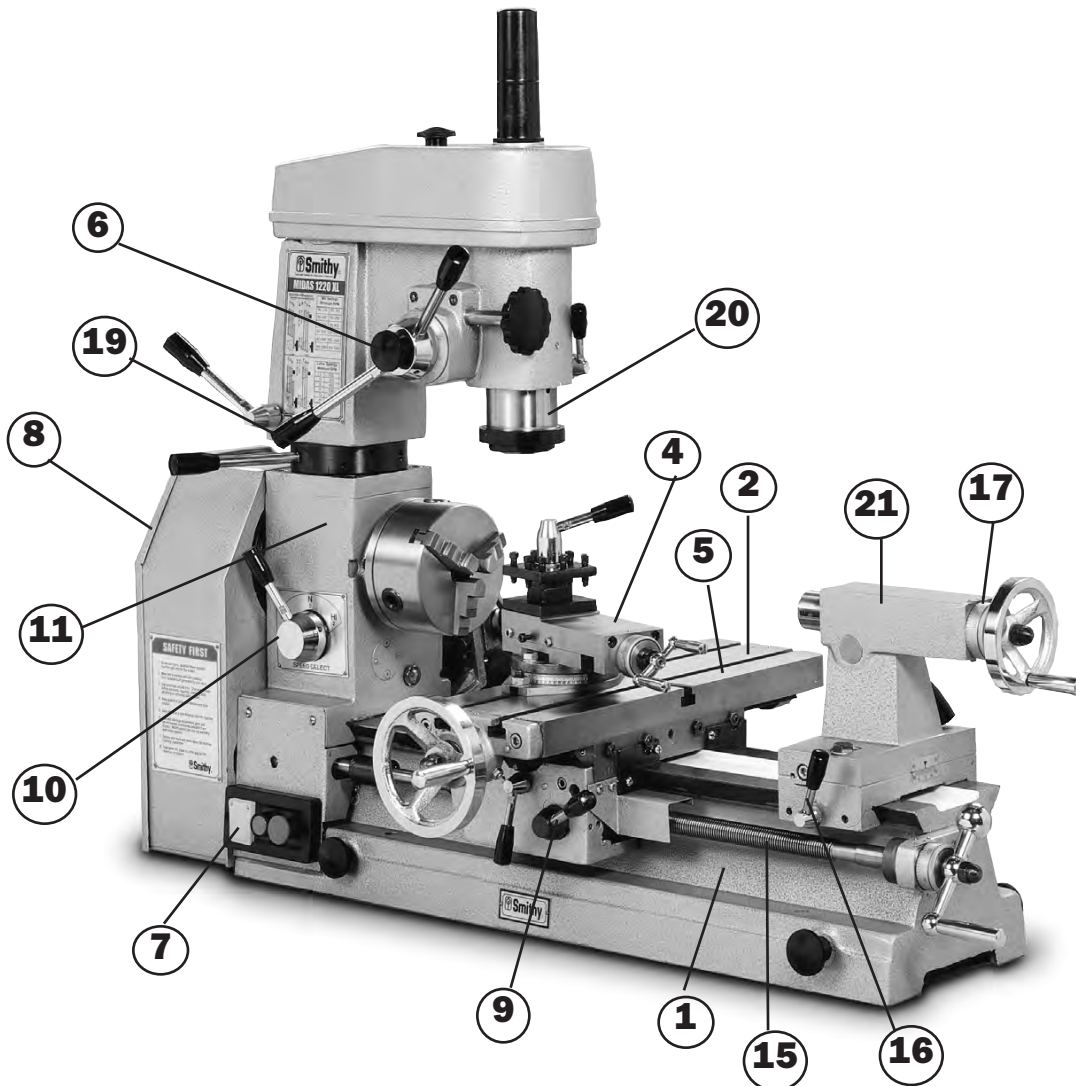

Figure 5.1 Basic parts of the MI-1220 XL

1. Bed - The Bed (Figure 5.1) is the machine's foundation. It is heavy, strong and built for absolute rigidity. The two ways on the top are the tracks on which the carriage and tailstock travel. To maintain an exact relationship between toolpoint and workpiece from one end of the machine to the other, the ways must be absolutely true and accurately aligned to the line of centers and to one another.

2. Carriage - The carriage consists of the saddle and apron. It moves by hand or power along the bed, carrying the cross slides, compound rest, and toolpost. Its function is to support the cutting tool rigidity and move it along the bed for different operations. It locks into place by tightening the carriage lock under the cross slide handwheel.

3. Change Gears - The change gears cut different thread pitches. They also determine the feed rate. Five change gears come installed on the machine; others are packed with it.

Figure 5.2 Your machine arrives with this gear configuration. The C gear, behind B meshes with D. Note the top two gears are permanent.

4. Compound Rest - Mounted on the cross slide, the compound rest swivels to any angle horizontal to the lathe axis to produce bevels and tapers. Cutting tools fasten to a toolpost on the compound rest. The calibrations on the front of the base are numbered in degrees from 60 degree right to 60 degree left.

5. Cross Slide - The T-slotted cross slide (Figure 5.1 and 5.3) moves crosswise at 90 degree to the lathe axis by manual turning of the cross-feed screw hand-wheel. It also serves as the milling table.

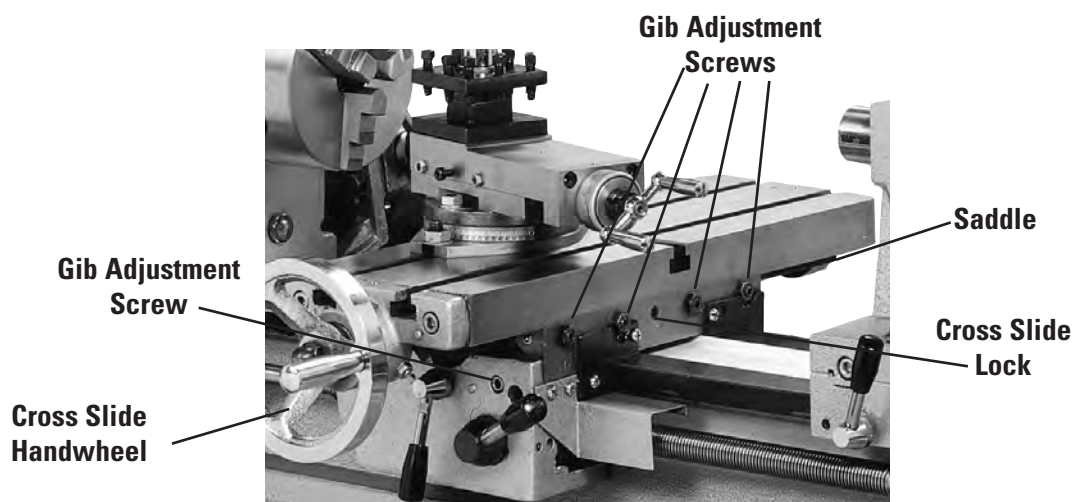

Figure 5.3 The cross slide moves laterally when you turn the cross slide handwheel.

6. Drill Press and Fine Feed Clutch - Pushing in the drill-press clutch engages the fine feed. To work the clutch, release the spring tension by rotating the drill-press handles clockwise. Pull the clutch out to use it as a drill press or push it in to the fine feed. Use the fine-feed handwheel to move the quill up and down.

7. Forward / Off / Reverse Switch - This is the main switch used to operate the lathe. It is simply a forward / reverse switch for the motor. The motor turns counter clockwise for normal lathe operation and clockwise for normal milling and drilling.

8. Gearbox - The gearbox (Figure 5.1 and 5.4) houses the belts that drive the spindle and change gears for the powerfeed. Select the thread pitch (for threading) or the feed rate (for turning) by changing the four change gears on the right side of the gear box.

Figure 5.4 The gearbox houses the belts and change gears.

9. Half-nut Engagement Lever - This lever, located on the apron, transmit power to the carriage when rotated 90 degrees to the right.

10. Half-nut Speed Selector - The two-speed selector for powering the leadscrew is on the front of the headstock. The leadscrew turns twice as fast in the II position as in the I position.

11. Headstock - The headstock, which is secured to the bed, houses the gears that drive the powerfeed and the taper bearings that secure the lathe spindle.

12. Lathe Belt Tensioner - To adjust the lathe belt (Figure 5.5), pull the tensioner handle forward to tighten the belt, back to loosen it.

Figure 5.5 To adjust the tension on the lathe belt, move the tensioner handle forward or back.

13. Lathe / Mill / Drill Clutch - The lathe/mill/drill clutch (Figure 5.4) are inside the gearbox. A three-position clutch, it transfers power to either the lathe or the mill, but not to both at the same time. To engage it, rotate it slowly while pushing or pulling on the clutch sleeve. Pulling it to the left runs the lathe, to the right (all the way in) runs the mill/drill. The middle is neutral.

14. Lathe Spindle - The end of the lathe spindle face in the tailstock is the spindle nose. The spindle nose, which has an MT4 taper, rotates the workpiece and drives lathe chucks and other work holding devices. All attachments such as three and four jaw chucks bolt to the spindle flange either directly or via an adapter plate.

15. Leadscrew - The leadscrew, which runs the length of the bed, moves the carriage for lathe turning or thread cutting. It works both manually and under power. You can also use it manually with the mill.

16. Locks - Locks on the cross slide (Figure 5.3) carriage (Figure 5.1), quill (Figure 5.6), and tailstock (two), Figure 5.1 and 5.7, keep them from moving. During machining, lock all lock except the one on the part you want to move.

Figure 5.6 The quill moves in and out of the millhead, carrying the spindle.

17. Micrometer Dial Collars - Just inside the handles of the tailstock (Figure 5.1), crossfeed (Figure 5.1), drill press (Figure 5.1), compound feed (Figure 5.1), and leadscrew (Figure 5.1) there are collars calibrated in inches. The compound feed, leadscrew, and crossfeed are calibrated in two thousandths, the tailstock in thousandths, and the drill press in 40-thousandths.

These micrometer dial collars can move independently around the handle shafts. This independent motion is called float. Floating dials on the cross slide, tailstock, and leadscrew let you zero the collars at any point and read the feed travel from that point on the dial for added accuracy.

18. Mill Belt Tensioner - To adjust the mill belt (Figure 5.7), swing the roller assembly to the front and place the belt on the back of the roller. Loosen the roller assembly and slide it back and forth in its slot.

Figure 5.7 With the millhead cover off, you can adjust the mill-belt tension.

19. Millhead Height Adjustment - Unlock the mill-head lock and place the height adjustment handle in one of the three holes in the black collar. Turn the collar to raise and lower the millhead.

20. Mill Spindle - The mill spindle (Figure 5.7) attaches to the quill, which moves in and out of the head. The quill lock keeps the quill still when you install or remove tools from it and while milling horizontally. Usually, tools fit into collets that attach through the spindle via drawbars.

21. Tailstock - The tailstock, which provides right-end support for the work, moves along the bed and can stop at any point. It has an MT3 taper and holds centers, drills, reamers, taps and other tools. To move the tailstock spindle, turn the tailstock hand wheel.

To offset the tailstock, adjust the two base-locking bolts (Figure 5.8). To offset to the left, loosen the left adjusting bolt and tighten the right. To offset to the right, loosen the right adjusting bolt and tighten the left.

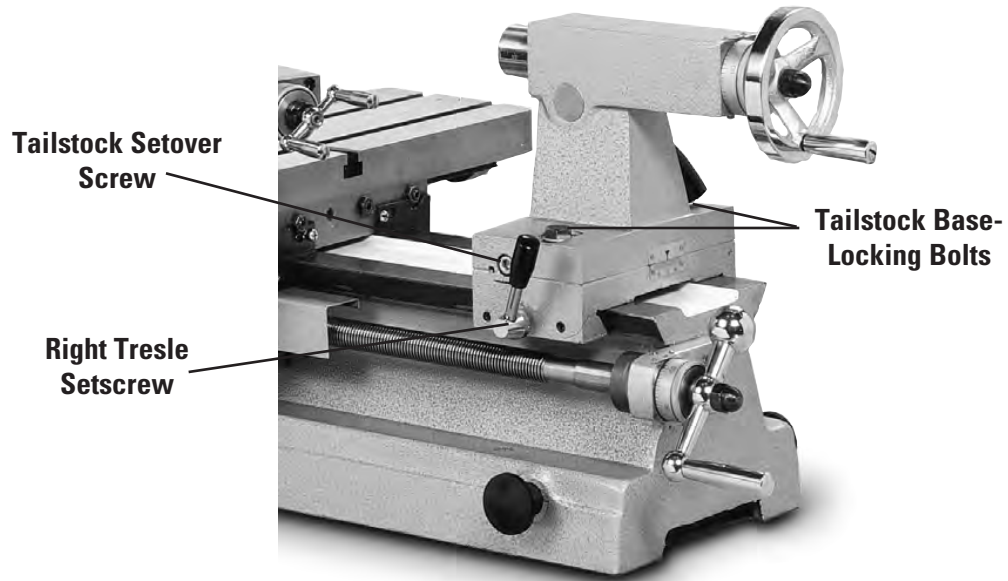

Figure 5.8 To offset the tailstock, adjust the base-locking bolts.

Chapter 6

Uncrating and Setting Up The MI-1220 XL

Moving the Machine

Moving a machine tool can be dangerous. Improper techniques and methods may injure you and/or damage the machine. To find a professional to move and site your Smithy machine to look in your local Yellow Pages under "Machine Tools, Moving and/or Rigging." If there is no such listing or your community does not have a rigging specialist, a local machine shop or machinist may be able to provide a referral.

When you pick up the machine at the shipping terminal, bring a crowbar, tin snips for cutting the metal straps, and a hammer. If there is obvious shipping damage to the crate, you'll be able to inspect the machine before signing for it. Note any damage on the bill of lading (shipping document). Fill out the claims form and notify both Smithy Co. and the shipping terminal about the damage. Failure to notify both parties can complicate and/or invalidate a claims process.

Trucking company terminals usually have forklifts to assist customers. It's most convenient to transport the machines in trucks without canopies and large vans.

Uncrating and Positioning the Machine

The machine is assembled, inspected and ready to go on its stand when you receive it. It's wrapped in a water and greaseproof cover, strongly braced, and crated. A box of accessories is also in the crate.

The metal bands around the crate are under tension. Wearing eye protection and gloves, cut the metal bands with tin snips. Be careful- the cut edges are sharp. The band secures the crate top to the base.

After removing the straps, lift off the crate top. Tip the crate from the tailstock end up and over the machine (Figure 6.1). Do not damage the crate; you may need it another time to transport the machine.

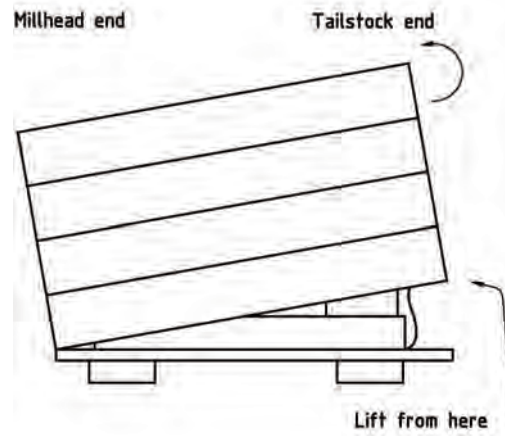

Figure 6.1 Tip the crate from the tailstock end up and over the machine.

Now open the accessories box. Check the items in it against the accessory checklist. After accounting for all parts, you're ready to move your Midas 1220 XL into its work position.

Four men can move the Midas 1220 XL using the four lifting handles (Figure 5.1). You can reduce the weight so two people can move it by following these instructions:

Millhead

1. Remove the four hexagon socket-head capscrews at the base of the millhead support column (Figure 6.2). If a screw runs through the belt box into the flange of the support column, remove it too.

Figure 6.2 Remove the millhead and column from the lathe head.

2. Lock the millhead locking handle (Figure 5.1)

3. Lift the millhead and column off the lathe head (Figure 6.2). You may have to rock it back and forth while lifting it.

Tailstock

1. Loosen the tailstock locks (Figure 5.1) and pull the tailstock off the end of the bed. The gib and the locking pin will fall out. Be careful not to lose them.

Three-jaw Chuck

1. Remove the three bolts behind the chuck that hold it to the spindle flange (Figure 6.3). The chuck will come off. Place a board between the chuck and ways to protect the ways.

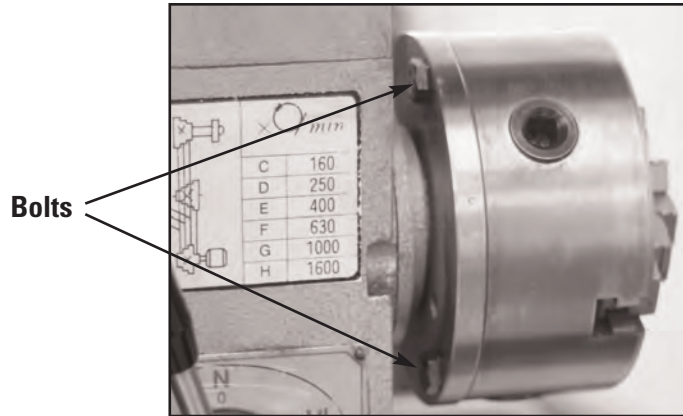

Figure 6.3 The chuck attaches to the spindle flange with three bolts. The one bolt located on the other side of the spindle does not show.

Put the machine on a strong, rigid table 40" long x 24" wide x 28 – 33" high. We recommend you bolt down the machine using the holes in the base of the bed or using the lifting handles the same way they held the machine to the shipping pallet.

Carefully lift the machines by the handles, move it over the stand, and lower it into position. Do not let any part of your body come between the machine and the stand. Bolt the machine to the stand, using one flat washer and one lockwasher per bolt.

Before permanently anchoring the machine, you may want to level the bed (Figure 6.4). The bed is rigid and supports itself, but having a level bed simplifies many setup operations. Use a precision level, both along and across the bed (Figure 6.5). Shim up any low points with sheet metal or other noncompressible material. After tightening the anchor bolts, check the bed again.

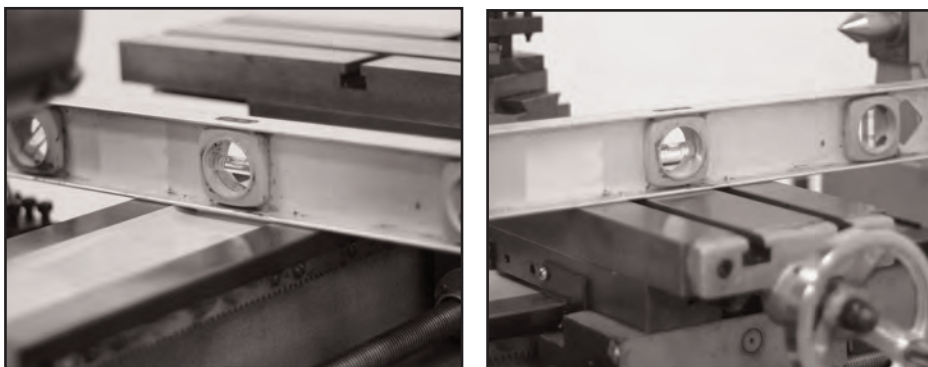

Figure 6.4 Check along and across the bed to make sure it is level.

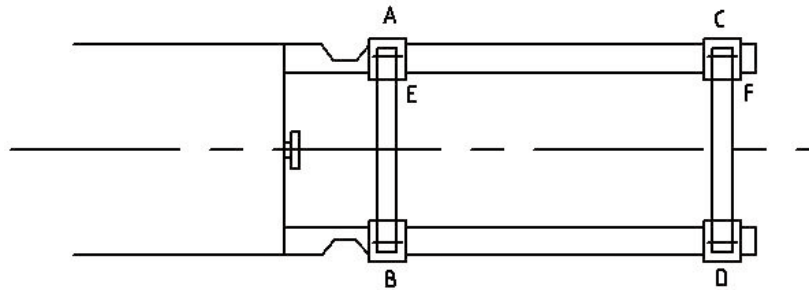

Figure 6.5 To check bench and bed level accuracies, successively place level at A, B, C, D (longitudinal positions) and E and F (transverse position). Bedways alignment in the longitudinal plane should be better than 0.0016/40" ; alignment in the transverse plane should be better than 0.0024/40".

Selecting a Location

There are several major considerations when selecting a location for your Smithy:

- 1.** Operation is from the apron side, so allow at least 40 – 48" clearance in front of the machine.
- 2.** The machine should be on a 30amp circuit and close to the power outlet. If you must use an extension cord, check with an electrician to make sure the cable can handle the electrical load.
- 3.** Provide ample working light over the operator's shoulder.
- 4.** Place the machine on a solid foundation-concrete, if possible. If the floor is wood, make sure it can support the machine and workbench. Brace it if necessary to prevent sagging or settling.
- 5.** Make allowances at the back of the machine tool, at the end, and above it for later additions, attachments, and/or accessories. Provide clearance on the left end for bar stock to be fed through the spindle. If you are considering placing more than one machine in an area, allow enough floor space to feed long bar stock to each machine.

Cleaning and Lubricating the Machine

Smithy machines are shipped with a protective grease coating. To remove it, spray on WD-40, let it sit for a few minutes, and wipe it off with rags. Use a brush and noncorrosive kerosene or white mineral spirits to clean hard to reach places.

Give special attention to the leadscrew. Use a brush or cotton string to clean down into the threads.

The best way to clean the powerfeed gears is to remove them completely. wipe the pulleys with a damp rag.

Once it's cleaned, your Smithy is ready for lubricating. Do this carefully and thoroughly before starting the machine. Use pressure oil can and good quality SAE No. 20 or 30 weight machine oil on the bearings and headstock.

To be thorough and complete, follow this routine:

Oiling the Headstock

1. Open the gearbox door to expose the change gears. Oil the button in the casting behind the D gear (Figure 6.6). Then put a few drops of oil on the teeth of all the gears. Grease the zerk on the A gearshaft.

Figure 6.6 Oil the button behind the D gear.

2. Check the sight glass under the chuck. If necessary, add oil until it is half full. The oil-fill plug is at the back of the headstock above the motor (Figure 5.5). Be careful no to overfill it. If you have to top it with oil, pour in only an ounce at a time and wait to see the results in the sight glass. Too much oil will make the motor lug and sling oil from behind the chuck and inside the belt box.

Oiling the Ways

1. Run the carriage as far to the left as possible. Put a few drops of oil on the ways. Run the carriage to the extreme right and repeat. You may want to use Way-lube, an oil specially formulated for ways.

Oiling the Carriage

1. Lubricate the oil buttons in the cross-slide table (Figure 6.7). There are two buttons on the front of the cross-slide ways.

Figure 6.7 Oil the buttons (circled) along the cross-feed table and cross slide.

2. Put a few drops of oil on the compound and cross-slide feedscrews.
3. Put a few drops of oil on the compound slides.

Oiling the Tailstock

1. Oil the buttons on top of the tailstock (Figure 6.8)

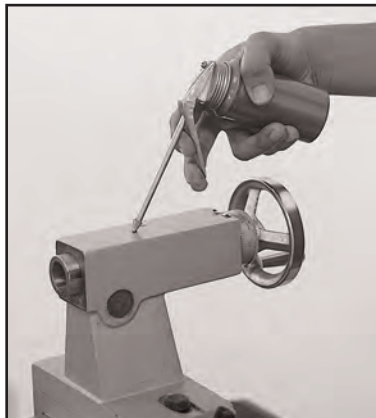

Figure 6.8 Oil the two buttons on the top of the tailstock.

Oiling the Apron

1. Put oil in the button just behind the cross-slide handwheel (Figure 6.7).
2. Put oil in the button at the back of the cross-slide (Figure 6.7).

Oiling the Leadscrew

1. Put oil in the oil buttons in the left trestle.
2. Put oil in the support for the right end of the leadscrew (figure 6.9).

Figure 6.9 Oil the support for the right end of the leadscrew.

3. Put a few drops of oil along the leadscrew and feed shaft.

Oiling the Compound

1. Put oil in the two buttons on the top.

Oiling the Mill/Drill Clutch

1. Put oil in the button on top of the clutch housing (Figure 6.10).

Figure 6.10 Oil the clutch-housing button.

To keep your machine in peak condition, lubricate it daily after removing any debris.

Setting up Your MI-1220 XL

The Midas 1220 XL comes with all major components assembled, but it is not ready to use right out of the crate. Do not start the motor until you correct the positions of the cross slide and leadscrew handwheels (Figure 5.1). We reversed these handles at our warehouse to protect them during shipment. A drop or two of oil on the shafts will help the handles slide on. Starting the motor with these handles in their shipping positions will damage the machine's gear, bearings, and handles. You must also install the tailstock handwheel, two drill-press handles, millhead lock handle and millhead height adjustment handle.

Setting Lathe and Mill Speeds

Changing belts changes lathe speeds. The lower speeds use the two short belts. There is only one position for the motor pulley to idler pulley belt. It goes on the smallest sheave of the motor pulley (behind the largest sheave, Figure 6.11) and on the largest sheave of the idler pulley. For 160 rpm, set the idler pulley to the lathe spindle pulley belt on the smallest sheave of the idler pulley to the largest sheave of the spindle pulley (position C). Move it in one sheave for 250 rpm (position D) and one more for 400 rpm (position E).

LOW	HIGH	 X
C D E	F G H	
		C
		160
		D
		250
		E
		400
		F
		630
		G
		1000
		H
		1600

Table 6.1Setting Lathe speeds (RPM)

For the higher speeds, remove the two small belts and use the single long belt from the motor pulley to the spindle pulley. For 630 rpm (position F), run the belt from the outside sheave (closest to the door) on the motor pulley to the largest sheave on the spindle pulley. Move it in one sheave for 1000 rpm (position G). For 1600 rpm (position H), run it from the largest motor pulley sheave to the smallest spindle pulley sheave.

Set mill speeds using various combinations of the lathe belts and the belt on top of the millhead. For 125 rpm, place the mill belt in position A and the lathe belts in position C (Figure 6.12). For 160 rpm, place the mill belt in position B and the lathe belts in position C, etc.

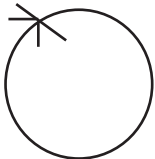
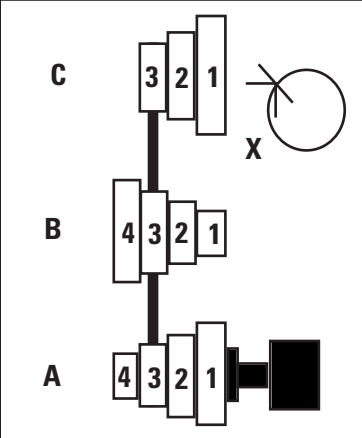

C	$\frac{A4 \times B1}{B4 \times C1}$	315	$\frac{A3 \times B1}{B3 \times C1}$	630	$\frac{A2 \times B3}{B2 \times C3}$	1250
B	$\frac{A4 \times B2}{B4 \times C2}$	400	$\frac{A2 \times B1}{B2 \times C1}$	800	$\frac{A1 \times B2}{B1 \times C2}$	1600
A	$\frac{A4 \times B3}{B4 \times C3}$	500	$\frac{A3 \times B2}{B3 \times C2}$	1000	$\frac{A1 \times B3}{B1 \times C3}$	2000

Table 6.2 Setting Mill/Drill Speeds (RPM)

Adjusting Belt Tension

To get maximum performance from your machine, keep the drive belts snug.

To adjust the tension on the mill belt, swing the roller to the front and place the belt on the back of the roller. Loosen the nut at the bottom of the roller and slide the roller in its shaft to the desired position. Tighten the nut (Figure 5.7).

When you use only the single long belt, the spring at the bottom of the idler-pulley bracket holds the idler pulley so it does not fall onto the motor pulley. To adjust the tension on the spring, loosen the pivot shaft (Figure 6.11) and tighten or loosen the spring as needed. Then retighten the shaft.

Figure 6.11 Adjust the spring tension on the idler-pulley bracket.

To tighten the lathe belts, move the tensioner handle above the motor (Figure 5.5) so it points toward the lathe head. Turn the knurled knob clockwise to tighten the belt and counter clockwise to loosen it. If there is not enough adjustment, remove the pivot pin and turn the knob as needed. Then reattach the pin.

Adjusting the Gibs

The Midas 1220 XL has straight gibs. Before using the machine, adjust the gibs to compensate for wear and maintain the proper fit between sliding surfaces. Gib adjustment affects cutting tool rigidity and the machine's ability to make accurate cuts.

As the gibs tighten, the effort it takes to turn the handwheels increases. Adjust the gibs according to the work you are doing and personal preference. What's important is to adjust them evenly. The tighter the gib, the more accurate it will be. Removing and polishing the gibs also improves the tolerances.

Before beginning, make sure the ways are clean and well-oiled. You must also understand locks for the compound, cross slide, carriage, and tailstock act directly on the gibs for their locking power. Back these locks off completely.

Cross-slide gib. Start adjusting the cross-slide gib with the table centered on the carriage. Back off all setscrews and jam nuts. Tighten the two inside setscrews all the way (Figure 5.3), locking up cross-slide movement. Then back off each setscrew one-quarter turn and check the movement. Finally, set the tension on the outer screws to match.

The effort it takes to move the table should be the same in both directions. If it is not, the gib is not adjusted evenly. If you feel more handwheel resistance when the cross slide is going away from you, the leading edge of the gib is too tight. Back off the setscrew closest to you a little to relieve the tension. If there is more resistance when the table is coming toward you, the leading edge of the gib is too tight, and you should adjust the screw furthest from you. When everything is set, hold the setscrews carefully with the Allen key and lock the jam nuts.

Carriage gib. The carriage has only two gib-adjusting screws, accessed through holes in the front of the apron (Figure 5.1). Start the adjustments as you did with the cross slide: tighten the screws all the way, then back them off one-quarter turn and test the setting. Handwheel resistance should be even in both directions.

The big difference between the cross slide and carriage is that the carriage gib travels with the carriage as it moves down the lathe bed. If you have more handwheel resistance when the carriage moves toward the tailstock, the leading edge of the gib is on the right side of the carriage, the same side as the direction you are moving the carriage. If you have more handwheel resistance when the carriage is moving toward the headstock, to left, release the tension a bit on the left-hand gib setscrew. As you work with the adjustments, you'll feel the difference even gib tension makes on the handwheels.

Compound gib. The compound gib has two adjusting screws and jam nuts (Figure 5.3). For greater tool rigidity, you can adjust the compound gib a bit tighter than the others.

Tailstock gib. The tailstock gib also has two adjusting screws (Figure 6.14). This gib can be free than the others so it is easier to position the tailstock. Again, the lock acts on the gibs. When tightened, it automatically brings the tailstock into alignment.

Figure 6.12 You can adjust the tailstock gibs with two setscrews, one on each side of the tailstock.

Reducing Backlash

Backlash of 0.008 – 0.015" as measured on the micrometer dials is normal. If you have more backlash than that, refer to the schematics at the back of this manual, if necessary, and follow these directions:

Crossfeed

- 1.** Tighten the setscrew on the bottom of the screw seat so the bushing inside the screw seat can not move.
- 2.** Tighten the cap nut so the handwheel is secure.
- 3.** Turn the handwheel one way, then the other. If a gap opens and closes between the dial and screw seat, you must install one or more shim washers (ask a Smithy technician about our antibacklash shim washer kit # K99-190)

To install shims, remove the handwheel, key, washer and the outer part of the dial and spring. Remove the inner hub of the dial. Install one or more shim washers between the bearing and the dial hub (Figure 6.13) and reassemble. Tighten the setscrew on the bottom of the screwseat as well.

Figure 6.13 You can reduce handwheel backlash with a shim (left) or by tightening the setscrew on the bottom of the screwseat (right). This locks the bush bearing

holds the screw and reduces any backlash.

Push and pull on the cross slide. If there is movement, remove the two bolts that attach the rear screwseat to the cross slide, remove the screwseat and screw the cross slide toward you until the screw comes completely out of the brass nut (Figure 6.14).

Figure 6.14 Adjust the tightening screws on the two-piece crossfeed nut to reduce the backlash between the screw and nut.

Remove the brass nut and put one or two strips of shim stock in the side of the hole. The fit should be tight. Screw the cross slide back onto the carriage. Adjust the screws in the brass nut to remove any play between the thread in the nut and screw. Reassemble the screw seat onto the cross slide.

Longfeed

1. Tighten the setscrew on the bottom of the right trestle so the bushing is tight (Figure 5.7).
2. If there is still excess backlash, remove the cap nut, hand crank, and key.
3. Remove the washer, outer dial, spring and inner-dial hub key.
4. Install as many shim washer as possible between the bearing and dial. Then reassemble.

Running In

Though all Smithy machines are tested at the factory and again before shipping from the warehouse, it is wise to put your machine through a break-in run before starting to work. After oiling the machine, check the belts to make sure the tension is correct. Do not plug in the machine yet.

Follow these steps:

1. Set the lathe to 160 rpm.
2. Plug the machine into a grounded 30 amp circuit.

- 3.** Start the motor by pushing in on the green button. To reverse the motor, push the red button to stop it, lift the cover over the rocker switch, and push the rocker switch either up or down to reverse the motor's rotation.

- 4.** During the run-in, try the controls. Get a feel for your machine.

Chapter 7

Turning

The lathe rotates a workpiece against a cutting edge. With its versatility and numerous attachments, accessories, and cutting tools, it can do almost any machining operation.

FPM	50	60	70	80	90	100	110	120	130	140	150	200	300
DIAM	RPM												
1/16"	3056	3667	4278	4889	5500	6111	6722	7334	7945	8556	9167	12229	18344
1/8"	1528	1833	2139	2445	2751	3056	3361	3667	3973	4278	4584	6115	9172
3/16"	1019	1222	1426	1630	1833	2037	2241	2445	2648	2852	3056	4076	6115
1/4"	764	917	1070	1222	1375	1538	1681	1833	1986	2139	2292	3057	4586
5/16"	611	733	856	978	1100	1222	1345	1467	1589	1711	1833	2446	3669
3/8"	509	611	713	815	917	1019	1120	1222	1324	1426	1528	2038	3057
7/16"	437	524	611	698	786	873	960	1048	1135	1222	1310	1747	2621
1/2"	382	458	535	611	688	764	840	917	993	1070	1146	1529	2293
5/8"	306	367	428	489	550	611	672	733	794	856	917	1223	1834
3/4"	255	306	357	407	458	509	560	611	662	713	764	1019	1529
7/8"	218	262	306	349	393	426	480	524	568	611	655	874	1310
1"	191	229	267	306	366	372	420	458	497	535	573	764	1146
1-1/8"	170	204	238	272	306	340	373	407	441	475	509	679	1019
1-1/4"	153	183	216	244	275	306	336	367	397	428	458	612	918
1-3/8"	139	167	194	222	250	278	306	333	361	389	417	556	834
1-1/2"	127	153	178	204	229	255	280	306	331	357	382	510	765
1-5/8"	117	141	165	188	212	235	259	282	306	329	353	470	705
1-7/8"	102	122	143	163	183	204	224	244	265	285	306	408	612
2"	95	115	134	153	172	191	210	229	248	267	287	382	573
2-1/4"	85	102	119	136	153	170	187	204	221	238	255	340	510
2-1/2"	76	91	107	122	137	153	168	183	199	214	229	306	459
2-3/4"	69	82	97	111	125	139	153	167	181	194	208	278	417
3"	64	76	89	102	115	127	140	153	166	178	191	254	371

Table 7.1 Provides exact speeds (rpm). It does not make machine speed limitation into account. Determine the desired rate of speed and find the closest speed available on your machine.

The modern lathe offers the following:

- The strength to cut hard, tough materials
- The means to apply power
- The means to hold the cutting point tight
- The means to regulate operating speed
- The means to feed the tool into or across, or into and across the work, either manually or by engine power, under precise control
- The means to maintain a predetermined ratio between the rates of rotating works and the travel of the cutting point or points.

Turning Speeds

When metal cuts metal at too a high speed, the tool burns up. You can machine soft metals like aluminum at fast speeds without danger or trouble, but you must cut hard steels and other metals slowly.

You must also consider the diameter of the workpiece (Figure 7.1). A point on a 3" diameter shaft will pass the cutting tool three times as fast as a point on a 1" diameter shaft rotating at the same speed. This is because the point travels a tripled circumference. For work in any given material, the larger the diameter, the slower the speed in spindle revolutions needed to get the desired feet per minute (fpm) cutting speed.

Lathes cut threads in various numbers per inch of material threaded, according to the operator's needs. The Midas 1220 XL cuts threads to metric or inch standards.

In thread cutting, the carriage carries the thread-cutting tool and moves by rotating the leadscrew (Figure 5.1). The basic principle is that the revolving leadscrew pulls the carriage in the desired direction and at the desired speed. The carriage transports the toolpost and the threading tool, which cut the thread into the metal being machined.

The faster the leadscrew revolves in relation to the spindle, the coarser the thread. This is because the threading tool moves farther across the revolving metal with each workpiece revolution.

The lathe spindle holding the workpiece revolves at a selected speed (revolution per minute, or rpm) according to the type and size of the workpiece. The leadscrew, which runs the length of the lathe bed, also revolves at the desired rpm. There is a definite and changeable ratio between spindle and leadscrew speeds. Figure 7.2 shows belt positions for various speeds.

Gear Ratios

The lathe lets you use various indicated gear combinations to cut the desired number of threads per inch (tpi), or the metric equivalent, or to advance the tool at a specified amount each revolution (feed rate expressed as inches per revolution (ipr))

The Midas 1220 XL has a pick-gear gearbox (Figure 5.2); gears are picked and placed to change the gear ratios. The gearbox mechanism determines the leadscrew's rotation rate in relation to the spindle's for threading, turning and facing. To change the thread pitch (tpi), replace the gears per Table 7.2.

											
Threads Per Inch						Metric Pitches					
Speeds		Gear Position				Speeds		Gear Position			
1	2	A	B	C	D	1	2	A	B	C	D
.003	.006	30	60	27	63	0.50	1.00	49	32	42	56
30	15	70	32	40	45	0.60		49	32	45	50
28	14	70	32	40	42	0.70		49	32	42	40
26	13	70	32	40	39	0.75	1.50	63	32	42	48
24	12	70	32	40	36	0.80		49	50	60	32
22	11	70	32	40	33		1.75	49	48	63	32
20	10	70	32	40	30	1.00	2.00	63	32	49	42
18	9	70	27	45	36	1.25	2.50	60	32	49	32
16	8	70	27	45	32	1.50	3.00	63	32	56	32
14	7	60	27	60	32						
12	6	70	27	60	32						

Table 7.2 Gear Ratios

Chapter 8

Metalcutting Theory

A machine tool is no more efficient than its cutting edge. Because lathe operations require continuous regrinding and sharpening of the machine's cutting tools, operators should know some metalcutting theory.

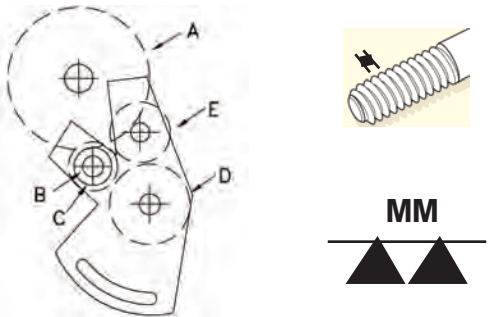
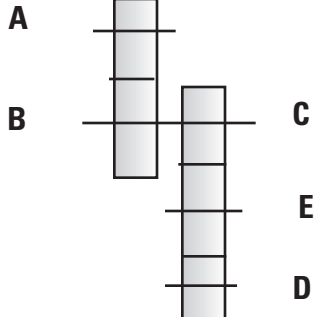
All cutting with a sharp edge, whether with the thin blade of a knife or the almost square edge of a closely supported carbide tool, is basically a wedging-apart action. The first essential of any wedging tool is a penetrating edge. The narrower the blade, the less force is needed to wedge it through the material. Therefore, when cutting comparatively soft materials with a cutting tool made from a much harder, stronger substance, the blade can be very thin and sharpened to a long, thin edge.

As the material hardness (or resistance to separation) increases, the strength of the cutting edge must also increase. A knife whose edge is too thin dulls quickly, even when cutting comparatively soft materials. This explains why, in Figure 8.1 the knife edge breaks off almost upon contact with the metal while the more obtuse cutting edge of a cold chisel stands up to continuous pounding.

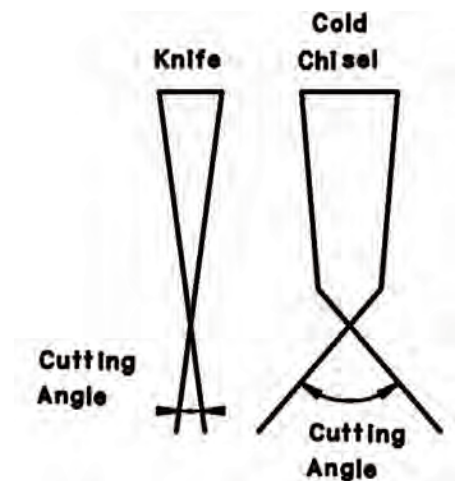

Figure 8.1 The knife edge breaks off almost upon contact with the metal because its cutting edge is not as strong as that of a cold chisel.

The primary requirements of the cutting edge of any metalcutting tool are that it be (A) strong and (B) closely supported. This is understandable when we realize how much downward pressure is exerted against the cutting edge. Pressure against cutting tools as great as 250,000 per square inch (psi) have been measured on large metalcutting lathes.

While the workpiece revolves, a strong, rigidly held cutting edge is forced under its surface. As it presses down against the cutting edge, small chips or a continuous ribbon of metal wedges away (Figure 8.2). Only in soft, ductile materials is this wedging action continuous.

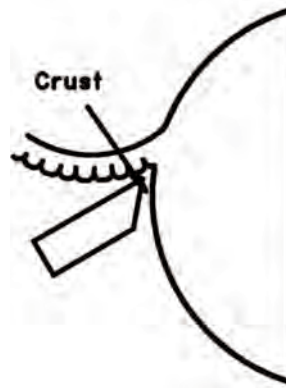

Figure 8.2 Wedging-off action in cutting hard steel. Note the false edge or crust that builds up on the cutting edge.

On harder substances, the wedging force compresses, rises to the shearing point, and shears. Then it builds up and shears again, repeatedly. You can see this in the distortion of chips when cuts are heavy and materials hard.

When the shearing vibration synchronizes with the natural vibration period of any part of the tool, toolholder, or workpiece, chatter occurs. You eliminate chatter by changing one of the harmonizing factors: making the tool more rigid, holding the cutter closer up in the toolholder, backing the toolholder farther into the toolpost, or altering the feed of the tool, operating speed of the lathe, or angle of the cutter bit to the workpiece.

Tool Sharpness

Instead of being the all important factor in determining tool performance, keenness of the cutting edge is just one of many factors. On rough or heavy cuts, it is far less important than strength, because a false cutting edge or crust usually builds up on the tool edge, and though the edge dulls, its angle often increases the cutting tool's efficiency by increasing its wedging action. Cutter shape is usually more important than edges, which generally are rough-ground and require honing for fine finishing cuts or work in soft, ductile materials like brass or aluminum.

Lack of clearance, which lets a tool drag on the work below the cutting edge, is a break on the lathe, greatly reducing pressure on the cutting point and interfering with tool performance more than edge dullness. At the same time, excessive clearance weakens a tool because of insufficient support to the cutting edge. Such an edge will break off if you use the tool on hard materials.

Clearance requirements change with almost every operation, but there are certain standards for all aspects of the cutting tool. You must not only provide clearance from the cutting edge; there must also be end and side clearance. To help the chip pass with minimum resistance across the top of the tool, it should often have top rake as well. You determine the shapes and rakes to which you'll grind your tools by the tool holder you use. The Midas 1220 XL has a four-sided turret toolpost that accommodates up to four high-speed-steel (HSS), carbide-tipped, or indexable carbide turning tools.

Heat

The energy expended at the lathe's cutting point converts largely into heat, and because the energy is great, the heat is intense. Before today's HSS, carbide and ceramic tools, this heat created a serious machining problem. Machining could be done only under a steady flow of coolant, which kept the tool from heating to its annealing point, softening and breaking down.

With HSS, you can usually cut dry unless your machine is running at extremely high speeds on continuous, heavy-duty production work. HSS tools are self-hardening even when red hot. They do not dissipate the heat, however, or in any way prevent the workpiece from heating up. Because steel expands when heated, it is a good idea, especially with long shafts, to check the tightness of the lathe centers often and make sure workpiece expansion does not cause centers to bind.

In everyday lathe operations like thread cutting and knurling, always use cutting oil or other lubricant. On such work, especially if the cuts is light and lathe speed low, dipping a brush in oil occasionally and holding it against the workpiece will provide sufficient lubrication. For continuous high-speed, heavy-duty production work, however, especially on tough alloy steels, using a cutting oil or coolant will increase cutting efficiency. It's essential if you're using a non HSS cutting tool. When you use coolant, direct it against the cutting point and cutter. Consider installing a coolant system if you don't have one.

	Low-Carbon Steel	High-Carbon Steel Annealed	Alloy Steel Normalized	Aluminum Alloys	Cast Iron	Bronze
Speed (sfm)						
Roughing	90	50	45	200	70	100
Finishing	120	65	60	300	80	130
Feed (ipr)						
Roughing	0.010-0.202	0.101-0.020	0.010-0.020	0.015-0.030	0.010-0.020	0.010-0.020
Finishing	0.003-0.005	0.003-0.005	0.003-0.005	0.005-0.010	0.003-0.010	0.003-0.010

Table 8.1 Cutting speeds and feeds for High Speed Steel Tools

Table 8.1 list cutting speeds and feeds for HSS cutters so you can set up safe rpm rates. The formula is as follows:

$$\text{rpm} = \text{CS} \times 4 / \text{D}''$$

where **CS** = cutting speed in surface feet per minute (sfm) and **D''** = diameter of the workpiece in inches.

To use this formula, find the cutting speed you need on the chart and plug that number into the CS portion of the formula. After calculating the rpm, use the nearest or next-lower speed on the lathe and set the speed.

If you were to make a finish cut on a piece of aluminum 1" in diameter, for example, you would see the desired sfm per Figure 8.3 is 300. Then

$$\text{rpm} = 300 \text{ sfm} \times 4 / 1$$

$$\text{rpm} = 1200 / 1$$

$$\text{rpm} = 1200 \text{ or next slower speed.}$$

For high-carbon steel, also 1" in diameter,

$$\text{rpm} = 50 \text{ sfm} \times 4 / 1$$

$$\text{rpm} = 200 / 1$$

$$\text{rpm} = 200 \text{ or next slower speed.}$$

With the four-turret toolpost, you can install all standard-shaped turning and facing tools with 1" on smaller shanks. The centerline is approximately 5/8" above the bottom of the turret. Smithy also offers quick-change tool sets that greatly speed up lathe operations. Contact a Smithy technician for details.

Chapter 9

Grinding Cutter Bits for Lathe Tools

High-Speed-Steel Cutters

The advantage of HSS cutter bits is you can shape them to exact specifications through grinding. This lets you grind a stock shape into any form. Stock shapes come in an assortment of types, including squares, flats, and bevels. Many shops buy their cutters as ready-ground or ready-to-grind bits or blades.

Ready-to-grind bits and blades are of specially selected HSS, cut to length and properly heat-treated. They are fine tools in the rough and generally superior to HSS shapes sold by the pound.

In grinding HSS cutter bits, you have five major goals:

- A strong, keen cutting edge or point
- The proper cutting form (the correct or most convenient shape for a specific operation)
- Front clearance away from the toolpoint
- Clearance away from the side of the tool (side rake)
- Free chip movement over the tool and away from the cutting edge.

Keeness angles can vary from 60° for mild softness to 90° for hard steels and castings (Figure 9.1).

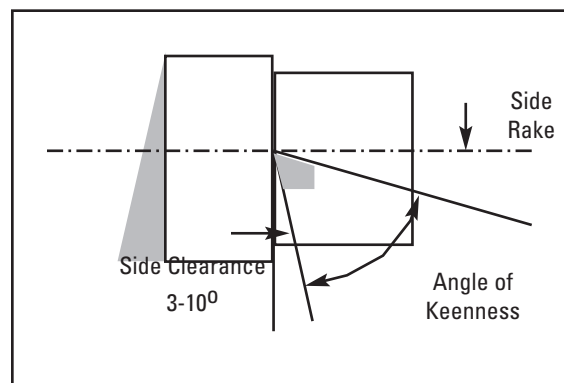

Figure 9.1 Keeness angles vary from 60 to 80 degrees.

Front clearance must always be sufficient to clear the work. If it is too great, however, the edge weakens and breaks off (Figure 8.2). Side and back-rake requirements vary with the material used and operation performed. Back rake is important to smooth chip flow, which is needed for a uniform chip and good finish, especially in soft materials. Side rake directs the chip flow away from the point of cut.

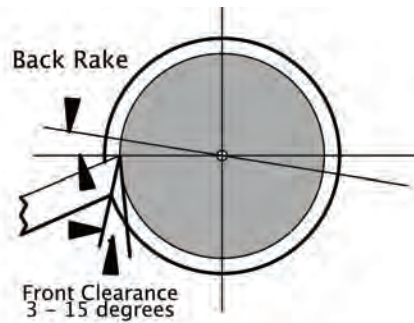

Figure 9.2 The edge weakens if front clearance is too great.

Grind cutters on a true-surfaced, good-quality, medium-grit grinding wheel (preferably an 8", 46-60A-grit or 68A-grit Carborundum wheel) at 6000 or 6500 rpm. When starting with an ungrounded cutter bit, the procedure (Figure 8.3) is usually to:

1. grind the left-side clearance
2. grind the right-side clearance
3. grind the end form or radius
4. grind the end clearance
5. grind the top rake, touching in a chipbreaker.

If you are honing the cutting edge (for fine finishing or machining soft materials), draw the cutter away from the cutting edge across the oilstone as shown in figure 9.4.

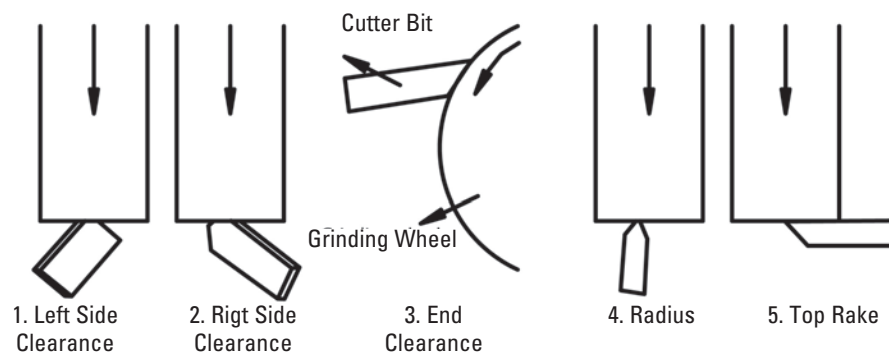

Figure 9.3 Grinding sequence for an unground cutter bit.

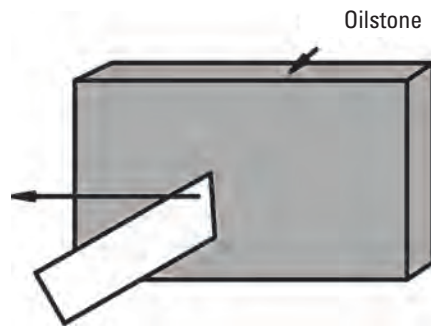

Figure 9.4 When honing, draw the cutter away from the cutting edge across the oilstone.

Materials Other Than Steel

As pointed out earlier, when grinding HSS cutters, we determine cutting angles primarily by strength requirements, not keenness requirements. Angles and rakes for general industrial shop use are established. In machining steel, the softer the steel, the keener the angle of the cutting edge. For soft steels, angles as acute as 61° are possible (Figure 9.5).

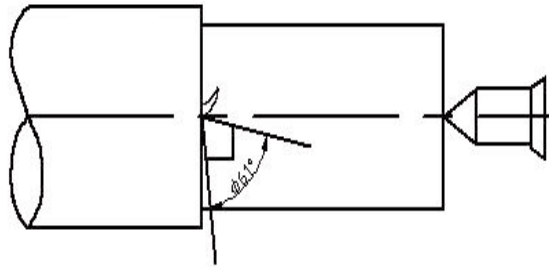

Figure 9.5 With soft steels, 61 degree angles are possible.

The same general rule applies to cast iron. Chilled or very hard cast iron requires tools with cutting-edge angles as great as 85° . For ordinary cast iron, you obtain greatest efficiency with a more acute cutting edge—approximately 71° (Figure 9.6).

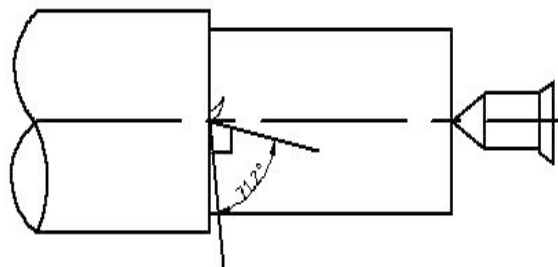

Figure 9.6 With cast iron, a 71 degree angle is most efficient.

Bits for Turning and Machining Brass

Brass tends to pull or drag when machined. It's best to machine it on dead center with the top rake in the horizontal plane of the lathe centers. Softer than steel, brass needs less support for the cutting edge. Brass cutters require an almost flat top angle and can gain greater angle keenness only in increased side and end rakes. It is often advisable to hone the cutting edges of cutters used to machine brass.

Note: All roundnose cutters are ground with flat tops and equal side rakes because they are fed across the work, to both right and left.

Special Chip Craters and Chipbreakers

When grinding cut-off blades, and occasionally on other cutter bits where the material's extreme hardness or toughness makes it difficult to control the chip leaving the work, it sometimes helps to grind a smooth, round crater just behind the cutting edge. This serves as a chip guide and starts the chip curling smoothly (Figure 9.7).



Figure 9.7 A crater starts the chip curling smoothly.

Using a Center Gauge to Check V-Thread Forms

It may be convenient to grind a standard cutter bit for thread cutting, especially for cutting standard 60° V-threads. When grinding an ordinary square cutter into a thread cutting tool, take care to ensure a true thread form. The easiest way is to use an ordinary center gauge for a standard V-thread tool or a special thread gauge for special thread forms.

To grind a cutter for an ordinary V-thread, grind first the left side of the tool, then the right side, to 30°. Be careful to grind equally from both sides to center the toolpoint. Then test for true form by inserting the newly ground point in the closest-sized V in a standard center gauge (Figure 9.8). Examine the gauge and cutter before a light. When the cutter is ground perfectly, no light streak shows between tool and gauge. Use a grinding chart for other rakes.

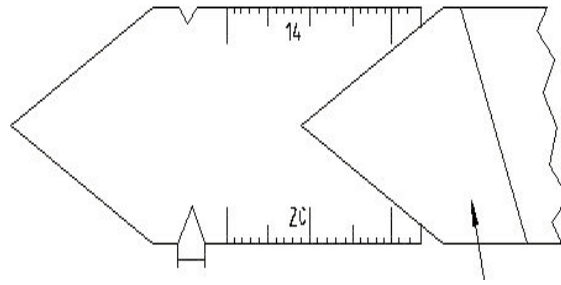

Figure 9.8 Insert the point into the nearest seized V in the center gauge.

Acme or Other Special Threads

Thread gauges are available for all standard threads. Before grinding such cutters, ascertain the correct pitch angle of the particular thread profile. For example, the pitch of an acme thread is 29° to a side, and the toolpoint is ground back square to an exact thread profile that requires a different end width for each thread size.

Thread forms must be accurate if threads are to fit snugly and smoothly. Every resharpener of this type of cutter requires regrinding the entire form. It is far better, when doing any amount of threading, to use a threading tool with a special form cutter. Sharpening such cutters requires only flat, top grinding, which does not alter the cutting profile.

Carbide-Tipped Cutters and Cutter Forms

Carbide is a compound of carbon and a metal. In cutting tools, it is usually carbon and tungsten. The hardness of carbide cutting materials approaches that of diamond. While carbides permit easy machining of chilled cast iron, hard and tough steels, hard rubber, Bakelite, glass, and other difficult or "unmachinable" materials, its primary use in industry is for long production runs on ordinary steels. On such work, carbide-tipped tools permit higher running speeds and much longer runs between sharpenings. The cutting edge of carbide tools stands up 10 to 200 times as long as the edge of HSS tools (Table 9.1).

The advantage of carbide is that it tolerates much higher heat than HSS or other alloys so you can run at higher speeds. The disadvantage is that it is more brittle than HSS and must have adequate support in the toolpost to prevent vibration and breakage.

Application	Use	Grade
Cast Iron	Roughing cuts	C-1
Non-ferrous, non-metallic, high-temperature alloys	General purpose	C-2*
200 and 300 Series stainless steels	Light finishing Precision boring Roughing cuts General Purpose	C-3 C-4 C-5 C-6*
Alloy steels	Finishing cuts	C-7
400 Series stainless steel, high velocity	Precision boring	C-8

Table 9.1 Carbide Types and Cutting Tool Applications

Chapter 10

Setting Up Lathe Tools

After selecting a cutter, insert it in the toolholder. Allow the cutter bit to project just enough to provide the necessary clearance for the cutting point. The closer the cutter is to the toolpost, the more rigid the cutting edge. Allen-head capscrews hold the tool in the toolpost. To assure maximum rigidity, don't let the tool extend too far beyond the end of the toolpost turret.

Cutting-Tool Height

After inserting the cutting tool into the toolpost, adjust the height of the cutting edge in relation to the lathe center. Insert a center in the tailstock. Then run the tool and center together.

The cutting edge on the tool should meet the point on the center. It may be necessary to use shims, which can be of various thicknesses and materials (Figure 10.1). Many seasoned cutting-tool height machinists use pieces of old hacksaw blades as shims. If the toolbit is too high, shim the back of the toolbit. If it's too low, shim the entire tool.



Figure 10.1 Placing shims under the tool can correct cutting too height.

Turning Tools

For general turning operations, set the point of the cutter bit slightly above the centerline of the work. In steel, the harder the material, the less above center (Figure 10.2, left).

Exceptions are soft brass, aluminum, and materials that tend to pull or tear. When machining these materials, set the cutter on dead center (Figure 10.2, right.)

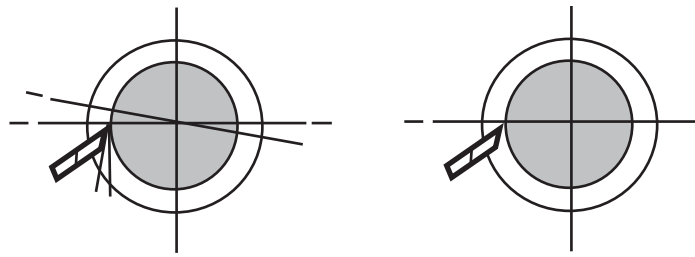

Figure 10.2 The harder the steel (left), the less above center you set the cutter point.
For soft brass and aluminum (right), set the cutter on dead center.

When cutting toward the headstock on most turning and threading operations, swing the compound rest to hold the shank of the toolholder at an angle. The angle should be approximately $29\text{-}1/2^\circ$ left of perpendicular to the line of centers, except for extremely heavy, rough-forcing cuts close to the limits. For such work, use a straight-shanked tool held perpendicular to the line of lathe centers in the right side of the toolpost. The tool will tend to swing out of the cut rather than hog into the work if you reach a stalling point (Figure 10.3)

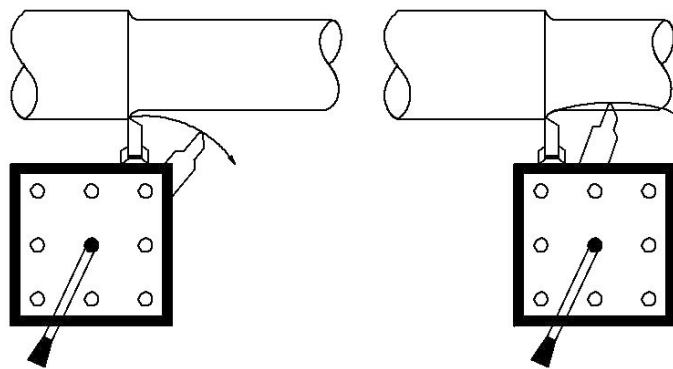

Figure 10.3 The tool will swing out of the cut (left) rather than hog into the work (right) if you reach a stalling point. Note the tool is in the right-hand side of the toolpost.

Threading Tools

Threading tools should always engage the work on dead center. Any deviation above or below will affect the thread profile (Figure 10.4).

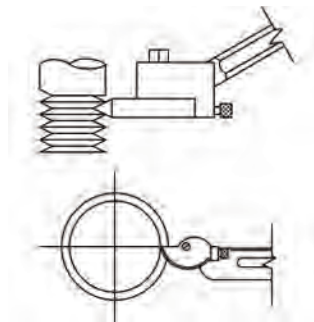

Figure 10.4 Threading tools engage the work on dead center.

Cutoff, Thread Cutting and Facing Tools

For cutoff, thread cutting, and facing, feed the cutter to the work on dead center (Figure 910.5). For the beginner, the average feed should not exceed 0.002 inches per revolution (ipr).

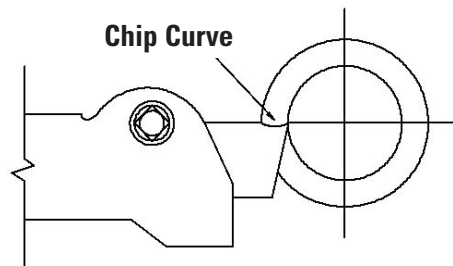

Figure 10.5 Feed the cutter on dead center for cutoff, thread cutting and facing.

Boring and Inside Threading Tools

For boring and inside threading, the cutter point engages the work on dead center (Figure 10.6). For greater cutting efficiency, position the bar while parallel to the line of lathe centers sufficiently below center to give the cutter a 14-1/2 degree approach angle. For internal threading, grind the top face of the cutter to compensate for this angle, giving a flat, true form top face.

Some machinists prefer to position the tool slightly above center when boring. With the bit above center, if a tool chatters it deflects down into empty space instead of into the workpiece.

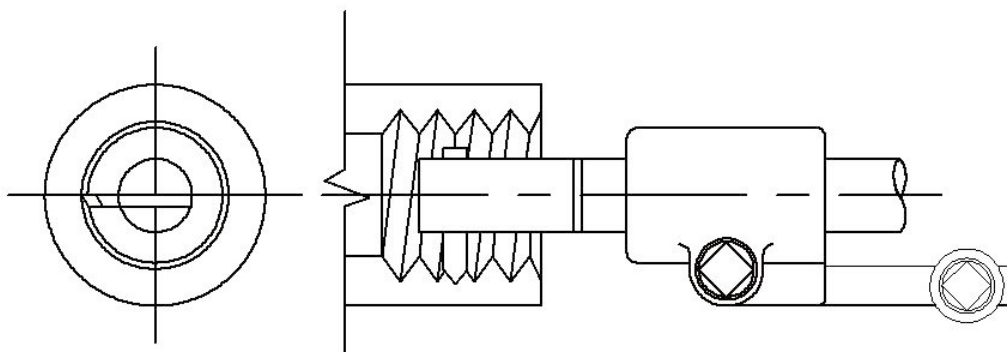

Figure 10.6 For boring and inside threading, the cutter point is at dead center.

Chapter 11

Setting Up with Centers, Collets, and Chucks

Before setting work up on centers, make sure the spindle and tailstock centers align accurately. Do this by inserting a center into the nose spindle and inserting the tailstock center into the tailstock ram. Then move the tailstock toward the headstock until the centers touch (Figure 11.1). You can correct any lateral alignment error by adjusting the tailstock set over screws (Figure 4.8).

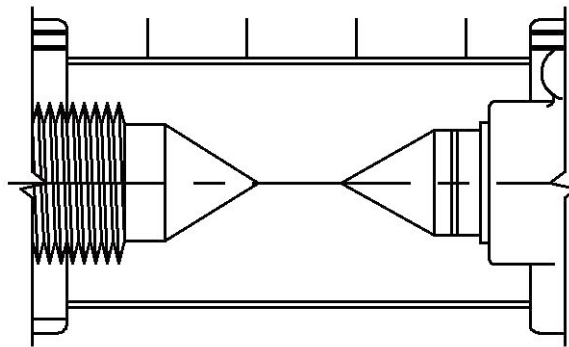

Figure 11.1 When aligning spindle and tailstock centers, move the tailstock toward the headstock until the centers touch.

For most turning operations, work is held in the lathe between the lathe centers by means of holes drilled in the ends of the stock to be machined. Your machining accuracy depends primarily on how precisely you locate these holes at the center of the bar or block. Locating these holes is called centering.

Centering

You can improve centering greatly by first squaring or facing the ends of the workpiece (Section 13.1). This gives you a true cross section in which to locate the centering holes.

- 1.** First, chuck the stock in the appropriate chuck. Let the stock protrude about an inch.
- 2.** Place a right-hand side tool (or a straight turning tool with a facing cutter) in the toolpost.
- 3.** Carefully adjust the cutting edge so it is exactly on center, then tighten it into the toolpost. If you don't do this, a small tit or projection will remain in the center of the stock and perhaps cause the center drill to run off center.
- 4.** Start your lathe on the slowest speed. Bring the tool into the cutting position against the center of the workpiece.

5. Feed the tool from the center of the stock outward, toward yourself, using the hand crossfeed. One or two light cuts is usually enough to true up an end roughened by the hacksaw. After facing one end, reverse the work and face the opposite end.

Centering a Round and Rectangular Stocks

1. You can center on round stock (Figure 11.2) with calipers, dividers, or special centering instruments (Figure 11.3). Centering square or rectangular stock is done by scribing lines from opposite corners. The intersection of these lines is the center (Figure 11.4).

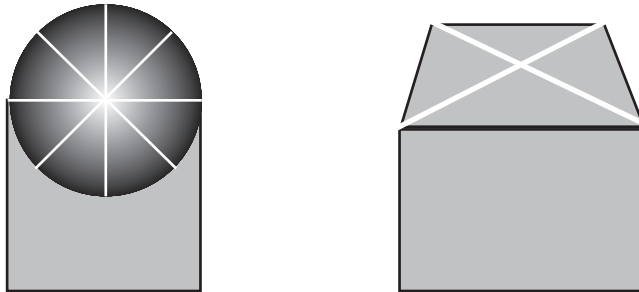

Figure 11.2 Centering on round stock and Figure 11.4 Centering on square or rectangular stock.



Figure 11.3 Use centering instruments include calipers and dividers.

2. After locating the center of each end, drive a starting depression for the drill into the stock with a center punch.

3. Check centering accuracy by placing the workpiece between the spindle and tailstock centers.

4. Revolve the headstock slowly against the tip of a tool or a piece of rigidly held chalk.

5. The chalk should touch just the high spots (Figure 11.5). If the center is off 0.002" or more, correct the position of the center by repunching at an angle.

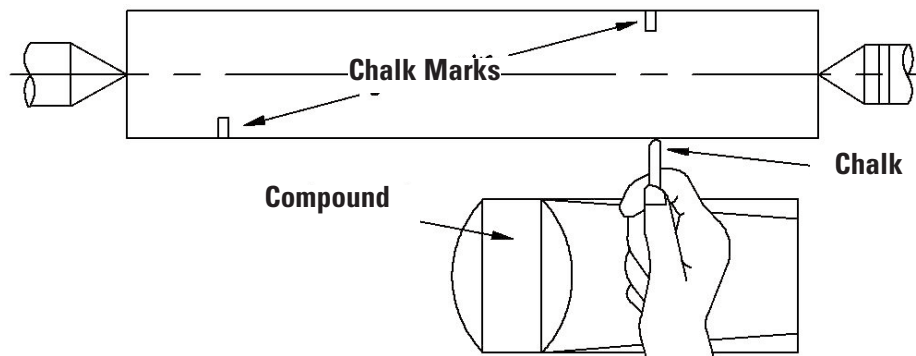

Figure 11.5 When you revolve the headstock against a piece of chalk, The chalk should just touch the high spots.

6. Next, drill and countersink the centers to conform to the profile of the lathe centers. This is best done with a combination center drill/countersink held in the tailstock arbor chuck. The centers now will take the lathe centers without play or chatter.

If a combination drill is not available, you can drill centers with a small drill and countersink them with a drill of sufficient diameter ground to a 60° point. A 60° taper is standard for lathe center points. Correct center depth is given in Figure 11.6. Take care to get an accurate 60° countersink in the center (Figure 11.7).

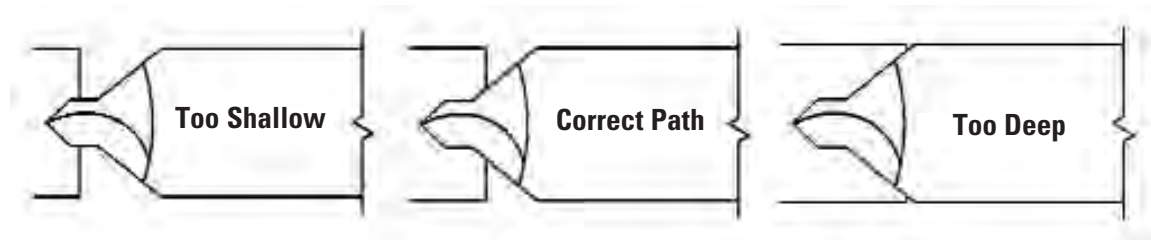

Figure 11.6 The correct depth of center is illustrated above. If it's too deep (bottom) only sharp outer edges will contact the center.

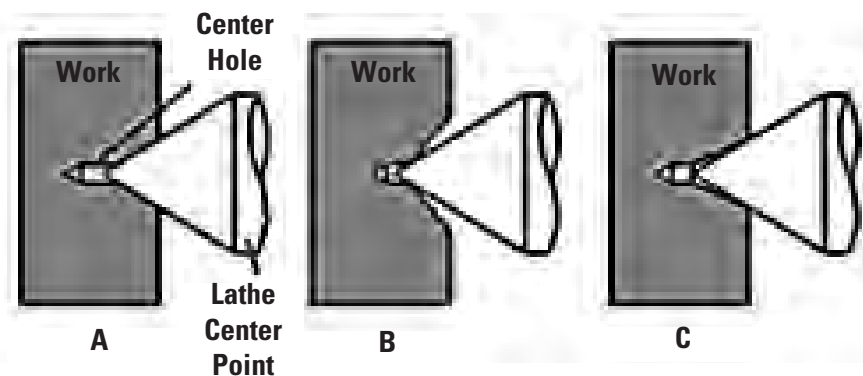

Figure 11.7 Counterbore centers with a drill to a 60° point so they fit the lathe centers (A). Too obtuse (B) or too acute (C) a counterbore will give insufficient bearing and destroy the lathe centers.

Mounting Work Between Centers

Remove the chuck from the lathe, bolt the faceplate to the spindle if I angle (Figure 11.8), and put in both headstock and tailstock centers. Fasten a lathe dog (Figure 11.9) to one end of the work. For ease of operation, use a live or rotating center in the tailstock end so you won't need lubrication.

Before centers starting the lathe, make sure the centers don't hold the workpiece too tightly. Heat may cause the workpiece to expand, so watch for binding. Adjust the tailstock center so the work turns freely but without end play.

If, after partially machining the workpiece, you find you must machine the stock under the lathe dog, remove the workpiece from the lathe and place the lathe dog on the machined end. Then turn this new tailstock center end of the shaft down to the desired diameter or form.

Figure 11.8 Bolt the faceplate to the spindle flange

Using a Clamp Dog

Standard lathe dogs drive round, or near-round, shapes. Rectangular or near-rectangular stock requires clamp dogs. In a properly made clamp dog, the under face of the heads of tightening screws are convex and fit into concave seats, while the holes in the upper bar are elongated. This design allows a firm grip of off-square shapes without bending the screws. Top and bottom bars should also have V-notches to give a firm grip on triangular or other odd-shaped stock. You can use clamp dogs or special V-jaw dogs also to hold highly polished round bars.

Using faceplates

For work setup, faceplates serve two purposes. First, they drive workpieces held between centers. Second, they hold workpieces shaped so you can't chuck them or mount them on centers.

Faceplates for driving workpieces on centers are generally small. They're notched and slotted to receive the tail of the lathe or clamp dog, bolt drive, or other driving tool (Figure 10.9). Faceplates for holding workpieces (irregularly shaped casting, machine, or die parts, for example) are usually larger and have varied designs. They may be T-slotted, drilled all over, or slotted and drilled. Workpieces mount on such faceplates with T-slot or standard bolts, strap clamps, angle plates, or other standard setup tools.

Figure 11.9 Fasten a lathe dog to one end of the work piece.

Note: Before starting to machine work set up on centers, check to see the lathe dog tail is free in the faceplate slot so it won't lift stock off its true line of centers, as in Figure 11.10. Also, be sure lathe centers fit closely into the center holes to eliminate side play but not so tightly they bind. If you're working on a long workpiece, check it frequently to be sure the center does not bind. Also, balance unbalanced setups with counterweights to overcome any "throw" as the work revolves (Figure 11.11).

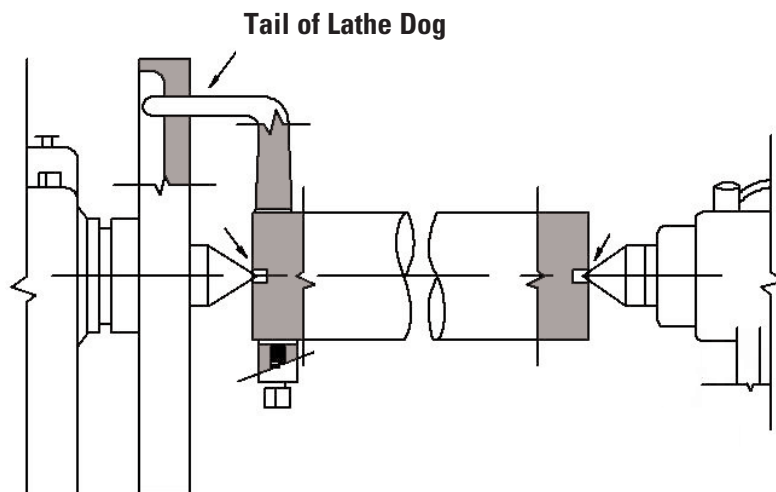

Figure 11.10 Make sure the lathe dog tail is free in the faceplate slot so it won't lift off the true line of centers.

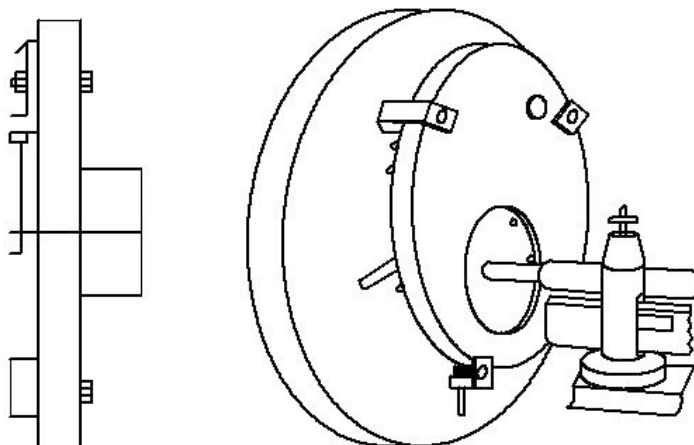

Figure 11.11 Counterweights can help with unbalanced setups.

Setting Up Work on a Mandrel

You can machine cylindrical or bored pipe work or cored castings too long to fit in a chuck by mounting them first on a mandrel (Figure 11.12). Then mount them between centers. The solid mandrels, which are driven into the hole of the work-piece, must be tight enough to turn the workpiece against the tool without slippage. Oil them lightly before driving them into the workpiece. Otherwise, the workpiece may freeze to the mandrel, making it impossible to remove the mandrel without damaging both workpiece and mandrel. When removing a mandrel, drive it back out of, instead of through, the hole.

You can purchase hardened steel mandrels, which have a slight (0.003") ground taper and an expanding collar, to facilitate mounting and demounting (Figure 11.13). Mandrels with compressible ends for holding single or ganged pieces are also available. When a workpiece is mounted on a mandrel, machine it as you would a solid shaft. You can drill eccentric centers in mandrel ends to permit eccentric turning.

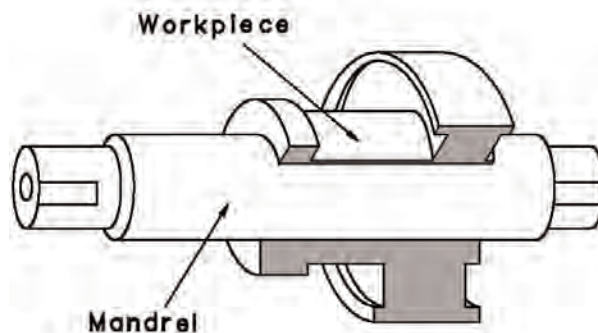

Figure 11.12 Mount workpieces too long for of the lathe centers.



Figure 11.13 Hardened steel mandrels have a slight ground taper and expanding collar.

Steady Rests and Follow Rests

Rests are for setting up (1) work that is relatively long in proportion to its diameter or (2) work whose dead end must be left free for boring or other operations. You can also use rests to machine slender shafts that are apt to spring out of alignment from the thrust of the tool. The purpose of a rest is to support the workpiece and maintain it in accurate alignment for machining. Rests are classed as steady rests or follow rests.

Steady Rests - Steady rests mount on the lathe bed (Figure 11.14). Clamped over the ways, they provide three bearing surfaces. These surfaces bear down lightly but rigidly against the surface of the shaft and keep it from moving out of the line without interfering with the operation.

To set up a steady rest, first center the work in the chuck and true it up. Then slip the steady rest into position and tighten it to the bed. With the bearing jaws clearing the work, close the top of the rest and tighten the locking screw. Now, with the lathe running, adjust the three bearing jaws to touch, but not push, the workpiece. Finally, test again for alignment, making sure the axis of the workpiece coincides with the axis of the lathe. Otherwise, the end will not be square and the surfaces and boring will be untrue. The tips of the jaws are bronze and require lubrication.

Figure 11.14 Steady rests mount on the lathe bed and provide three bearing surfaces

Follow Rests - Long or slender shafts that are apt to spring out of have a slight ground taper and alignment by the thrust of the cutting tool often require a follow rest expanding collar (Figure 11.15). Follow rests mount on the carriage of the lathe and move with the tool, backing up the workpiece opposite the point of the tool thrust. They have two adjustable supporting jaws, one holding the work to keep it from climbing up on the tool and the other behind the work to counter the thrust of the tool.

Note: Take great care in adjusting the jaws of rests, as they must form a true axial bearing for the work and let it turn freely but without play.

Figure 11.15 Follow rests mount on the lathe carriage and move with the tool.

Setting Up Work in a Chuck

Chucks usually hold work that is too short to hold conveniently between centers or work requiring machining at, into (boring or inside threading), or across its end. While it is possible to set up such work on a faceplate, the convenience of chucks has made them part of every complete lathe. Lathe chucks come in many types and sizes and hold workpieces of diameters approaching the swing of the lathe.

For ordinary use, there are two standard types of headstock chucks. The four-jaw independent lathe chuck has four holding jaws that can operate independently and adjust to hold round, square, eccentric, or odd-shaped work (Figure 11.16). The three-jaw universal geared scroll chuck holds only round or near-round work with three, six, nine, 12, or other multiple-numbered sides. It always holds work concentrically. The three-jaw chuck has the advantage of being self-centering—all jaws move in or out together (Figure 11.17).



Figure 11.16 Four-jaw independent lathe chucks hold round, square, eccentric or odd shaped workpieces.



Figure 11.17 Three-jaw universal geared scroll chucks hold round or near-round workpieces.

Mounting Work in a Four-Jaw Independent Lathe Chuck

For small-diameter, short work, insert jaws in the chuck with high ends to the center. This gives the maximum gripping and tool clearance (Figure 10.18). For large-diameter work, insert the jaws in the chuck slots with the high steps of the jaws to the outside of the chuck (Figure 11.19).

To place work in a chuck, follow these steps:

- 1.** Adjust the chuck jaws to the approximate opening to receive the work. Roughly center them by matching the nearest concentric ring on the chuck face with the corresponding mark on the jaws.
- 2.** Place the work in the chuck and grip it. Turn up the opposing jaws a uniform number of turns with the key provided. This will hold the work in position. Then bring in the other pair of opposing jaws the same way.
- 3.** Revolve the spindle slowly with your left hand while holding a piece of chalk until the chalk touches the high point (the nearest surface) of the work (Figure 11.6).
- 4.** Guided by the chalk marks, readjust the jaws until a chalk line lathe chucks hold round, will carry completely around the work. Then tighten all the jaws securely. square, eccentric, or odd-shaped workpieces.

For greater accuracy, after roughly centering the stock using chalk, set a dial indicator at the back of, and square to, the stock. Make sure you can see it clearly. Rotate the chuck by hand. Looking at two opposing jaws, determine which side is higher. Align the higher side with the dial indicator, loosen the opposite jaw, and tighten the higher jaw. Do the same with the other two jaws. Repeat the process until you have located the stock within necessary tolerances.

When making several identical pieces, after completing each workpiece release only two adjoining jaws, leaving the others to hold the center. The jaws of the four-jaw independent chuck are reversible. You can insert them with high steps to the inside or outside.

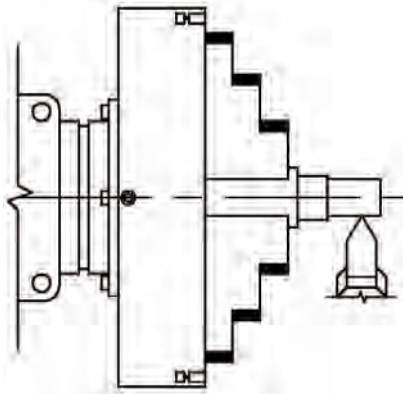
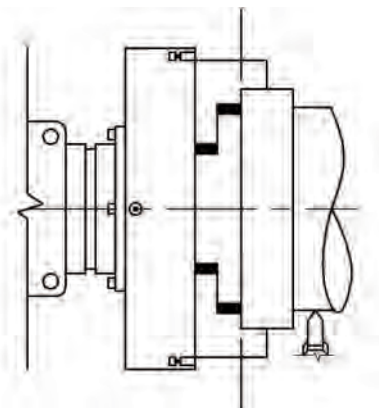

Figure 11.18 For short, small-diameter workpieces, insert the jaws with high ends to the center.

Figure 11.19 For large-diameter workpieces insert the jaws with high steps of the jaws to the outside.



Caution

Never leave the chuck key (wrench) in the chuck while the chuck is on the spindle. Any movement of the spindle can crash the key into the ways, seriously damaging the ways, spindle, and chuck. Turning on the lathe with the key in the chuck can seriously damage your lathe. The key can also be thrown when the lathe starts, causing damage and/or injury. Never let your hand leave the chuck key unless you are picking it up or storing it.

Never remove a chuck or heavy faceplate without first laying a board across the ways to protect them in case the chuck falls when it comes off the spindle nose. Or use a chuck cradle to ease chuck removal and installation.

Mounting Work in a Three-Jaw Universal Chuck

Work is set up in a three-jaw universal chuck as in a four-jaw independent chuck, with these exceptions:

- On three-jaw chucks, the key moves all the jaws at once.
- You need not center or check for concentricity because these chucks center automatically.
- Jaws are not reversible. Each chuck comes with two sets of jaws. One is for setups with high steps toward the inside (inside jaws), the other for mounting in the chuck with high steps to the outside (outside jaws).
- When installing the chuck jaws on a three-jaw chuck, install them in numerical order and counterclockwise rotation.

Each jaw is stamped with a serial number and jaw number (#1, #2, or #3). The slots in the chuck are not numbered, but there is a serial number stamped at the #1 slot (Figure 11.20). With the #1 slot in the 12:00 position, the #2 slot is at 8:00 and the #3 slot at 4:00 (Figure 11.21).

To install the jaws, first insert the #1 jaw into the #1 slot and turn the key until it engages. Then put in the #2 jaw and engage it, then the #3 jaw.

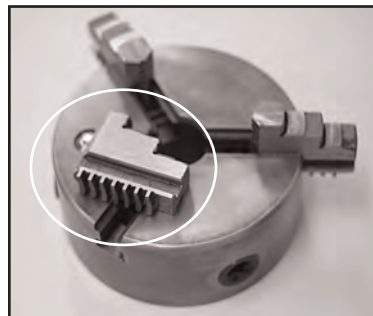

Figure 11.20 A serial number is stamped in the #1 slot of the three-jaw chuck.

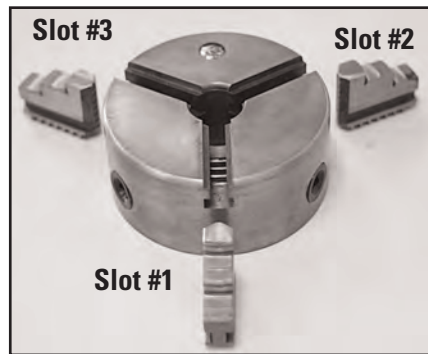

Figure 11.21 With the slot for the #1 jaw in the 12:00 position, the slot for the #2 jaw is at 8:00 and the slot for the #3 jaw is at 4:00.

Collets and Collet Attachments

To hold small-diameter work, whether bar stock fed through the hole in the spindle or small pieces of semi finished parts, collet attachments are preferable to standard chucks (Figure 11.22) for several reasons:

- They have much faster release and grip actions.
- They center the work automatically and accurately
- They grip even small pieces and pieces with a short hold firmly.



Figure 11.22 Collet attachments are best for small-diameter work.

- They are housed within the spindle nose for maximum tool clearance, making it possible to machine, thread, or cut off close to the spindle.

While chucks are universal tools that hold a range of stock sizes and shapes, collets are special tools. There is a collet for every size and shape of workpiece.

Made with extreme accuracy, hardened, and ground, standard split collets are slotted so their jaw ends compress inwardly to grip the workpiece. This is done by pulling the collet jaw's externally tapered shoulder into a matching taper-bored adapter sleeve. The adapter sleeve connects the lathe spindles MT5 taper to the collets MT3 taper. A drawbar holds the collet in place.

Toolpost Grinders

A fully equipped lathe has a toolpost grinder, a small, independently operated grinding head with an integral electric motor that mounts as a unit in the toolpost T-slot of the compound rest. (For lighter work, some are held in the toolpost.) You can maneuver it as you would any other cutting tool.

Toolpost grinders come with wheels of different shapes, sizes, and grits for grinding different materials and surfaces. They also come with arbors and mounted wheels for grinding internal surfaces. You can use them to grind or polish surfaces; to grind lathe centers, arbors, taper sockets, leader pins, gauges, valve seats, and other close-fitting parts; and to sharpen tools.

Chapter 12

Lathe Turning

Rough Turning

- 1.** In turning a shaft to size and shape where you have to cut away a lot of stock, take heavy, rough cuts to get the work done in the least time. Use a transverse powerfeed for heavy cuts-from right to left toward the headstock so the thrust is against the headstock or the chuck. Use a right-hand turning or round nose cutter.
- 2.** After selecting a cutter, place it into the left side of the turret (Figure 12.1). The cutter's point should be just above or on the line of the centers. The greater the diameter of the work, the higher the cutter can be. Adjust the height by placing shims under the cutter and raising or lowering it (Figure10.1).

Figure 12.1 Place a cutter into the left side of the turret.

- 3.** With the tool properly positioned, tighten the Allen capscrew.
- 4.** Next, run the carriage to the right end of the workpiece with the crank. Make sure the lathe is set to feed toward the headstock.
- 5.** Now determine the depth of the cut. Move the tool to the desired depth till it just touches the stock and zero the cross-feed dial.
- 6.** Start the lathe. Run the crossfeed in by hand to take as heavy a cut as is consistent with the power of the drive or the amount of metal to remove.

Say, for example, you need to reduce a diameter by a known number of thousandths of an inch. If you zero the collar and watch the movement of the dial, you'll know the depth of the feed from the zeroing point.

Note: The dial gives a good approximation, but for exact measurements, use a measuring instrument.

To reduce the diameter, advance the tool only half as many thousandths on the dial. This is because the tool takes off an equal amount from both sides as it cuts a continuous strip around the work. For example, to reduce the diameter of a shaft 0.005", you advance the tool only 0.0025", or 1-1/4 calibrations.

Engage the tool before setting the floating dial. The tool must be moving in the direction you want to go before you set the dial to zero to compensate for the backlash.

For a screw to move, there must be some play in the thread. When backing the cutting tool away from the cut, move the feedscrew enough to take the backlash before setting the collar or when the drawing the tool from the cut. Normal backlash is 0.008 – 0.015".

Engage the longitudinal feed by rotating the half nut lever 90 degree to the right. Always cut deeply enough to reach below the scale on oxidized bars or iron castings. Hard, oxidized surfaces dull tools rapidly.

Finish Turning

- 1.** After you have rough-turned the workpiece to approximate finished size (within 1/32"), replace your cutter bit with a freshly ground, keen-edge cutter.
- 2.** Make one or more light finishing cuts across the machined surface.
- 3.** Check the diameters carefully with a calliper or micrometer to be sure you are working to proper dimensions. Remember: the diameter will reduce twice the thickness of the cut.

For rough turning, most machinists prefer a deep cut and a comparatively fine feed, but the reverse is true for finishing cuts. They usually use a very light crossfeed and a coarse transverse feed with a cutting edge wider than the feed per revolution. In figure 12.2, the left-hand tool illustrates the first roughing cut and the right-hand tool shows the following finishing cut.

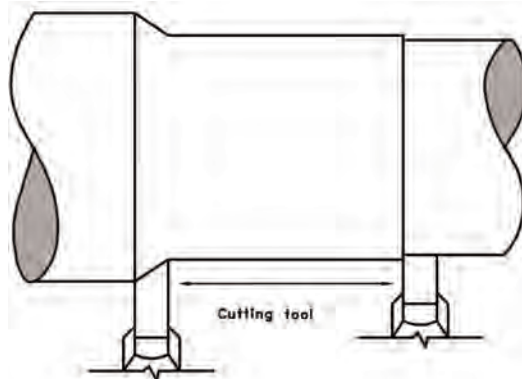

Figure 12.2 Roughing (left) and finishing (right) cuts.

Turning to Shapes

Other turning cuts, machining shapes, corners, fillets, etc., are done the same way. The main difference is in selecting cutter bits and maneuvering the cutting point by means of various cutting tools (Figure 12.3).

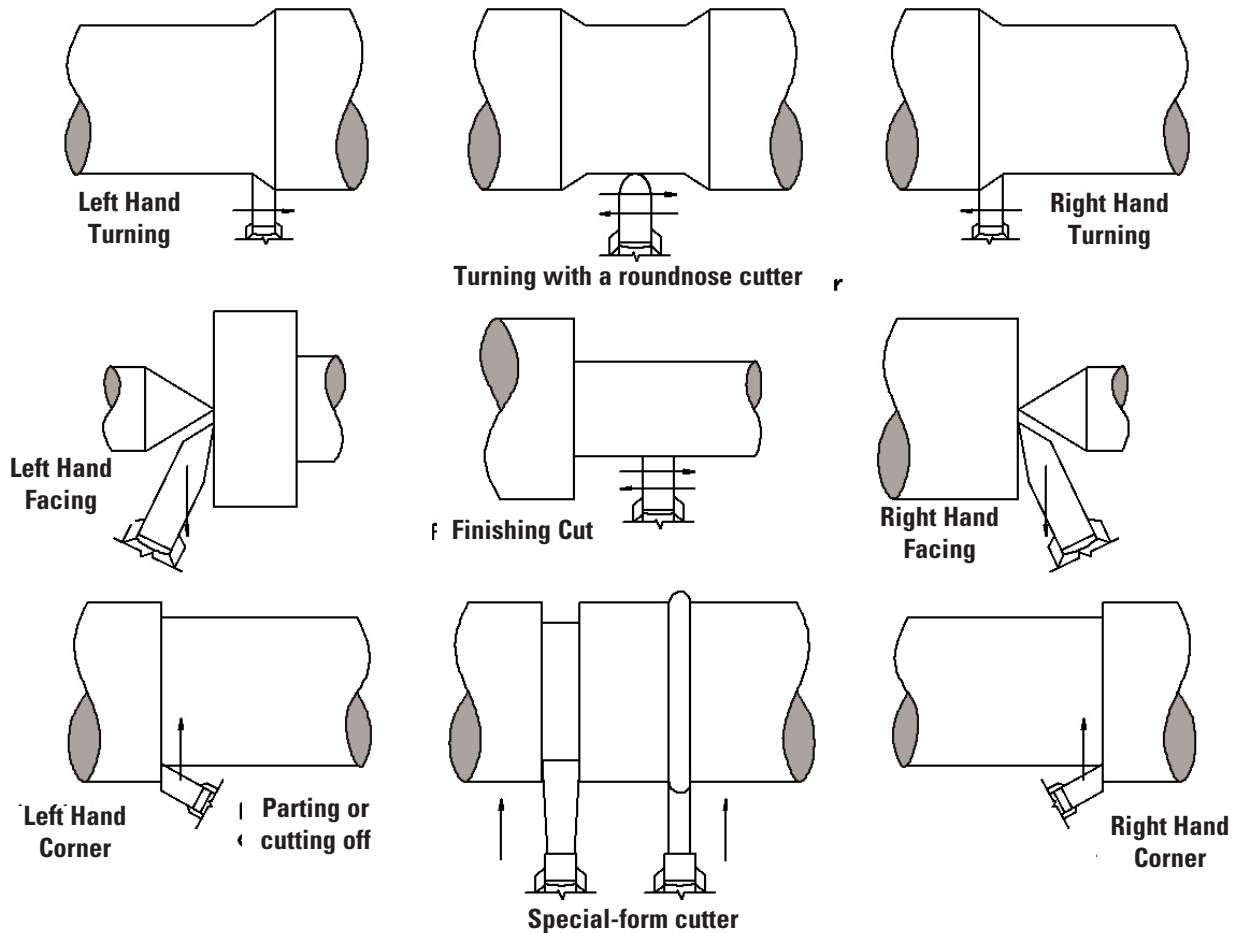

Figure 12.3 You can do other turning cuts with different cutter bits and cutting tools.

Machining Square Corners

To machine an accurate corner, follow these steps:

1. Set the compound rest perpendicular to the line of the center and insert a right or left-hand corner tool.
2. Using the longitudinal feed, turn a small diameter to finish up to the shoulder.
3. With the compound rest, feed the tool the amount needed to finish the work to the length, taking to the last facing cut across the shoulder away from the center.

Finishing and Polishing

After machining, you'll want a smooth, polished surface free of machine marks. You'll obtain the best results with a toolpost grinder. If you don't have one, use a file.

With a file, take full, biting strokes across the revolving workpiece at a slightly oblique angle. Do not drag the file back across the workpiece; instead, lift it clear for each return stroke. Use a clean, dry file and keep the workpiece clean, as well. Wipe the workpiece dry and clean if you've used coolant or cutting oil. Never hold the file stationary while the workpiece is revolving (Figure 12.4).



Figure 12.4 With a file, take full strokes at an oblique angle and never hold the file still.

For an even finer file finish, rub railroad chalk into its teeth. This provides additional lubrication and absorbs filings. Do not use blackboard chalk.

After filing off the machining marks, polish the workpiece with emery or other abrasive cloth. Keep the lathe turning at high speed and spread a few drops of oil on the workpiece. Don't stop moving the cloth (Figure 12.5).

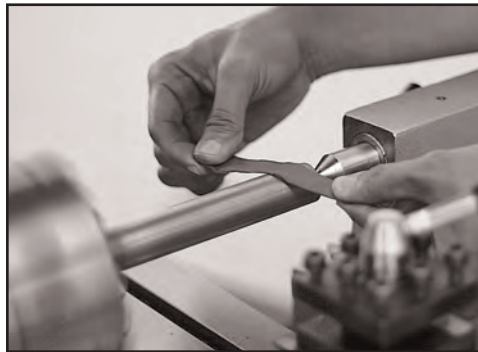

Figure 12.5 You can polish a workpiece with an abrasive cloth and oil.

Taper Turning

There are two ways to turn a taper: with the compound rest and by setting over the tailstock. In both methods, the cutter must engage the work on dead center if the taper is to be accurate.

Compound Rest. Tapers cut with the compound rest are usually short, abrupt angles, such as centers, bevel gear blanks, and die parts (Figure 12.6). In general, these are not considered taper turning, which applies to machining longer, more gradual tapers.

Setting over the tailstock. Cutting tapers by setting over the lathe tailstock involves misaligning the lathe centers. The lathe centers move from their position parallel to the tool's transverse travel, giving the desired degree of taper (Figure 12.7) The tailstock has a set-over scale calibrated both forward and backward from the straight turning or zeroing point for measuring set-over distances.

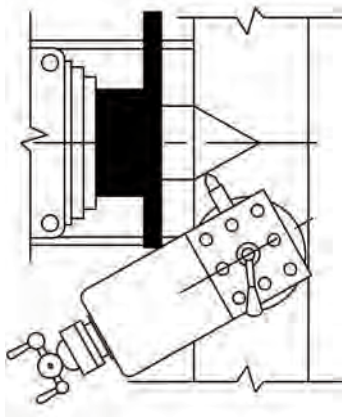

Figure 12.6 Tapers cut with the compound rest are usually short, abrupt angles.

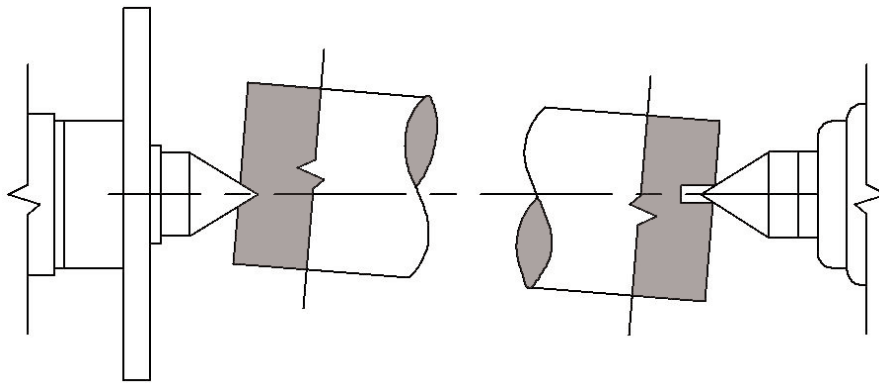

Figure 12.7 In setting over the tailstock, the lathe centers move from their parallel position with the tool's transverse travel.

To offset the tailstock, adjust the two base-locking bolts (Figure 5.8). To offset to the right, loosen the right adjusting bolt and tighten the left. To offset to the left, loosen the left adjusting bolt and tighten the right.

You can turn long, gradual tapers by setting over the tailstock, but take care. Your computations must be nearly perfect, because an error will spoil your work.

The distance of tailstock set-over needed to machine any given taper depends on three factors:

- The differential between the finished diameters of the extreme ends of the taper
- The length of the taper in relation to its extreme diameters, if the entire shaft is to be tapered
- The ratio between the length of the shaft (or work between centers when you're tapering only part of the shaft).

When the taper extends the entire length of the workpiece, tailstock set-over should equal half the difference between the finished diameters of the ends (Figure 12.8). When a taper extends only part of the length of the shaft, divide the total shaft length by the length of the portion to be tapered. Then multiply the resulting quotient by half the difference between the extreme diameters of the finished taper.

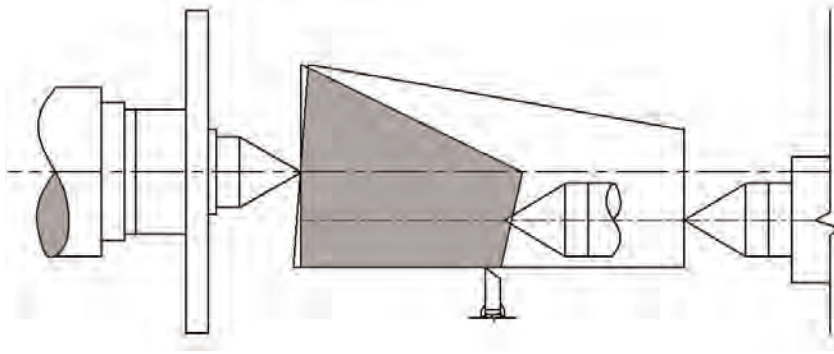

Figure 12.8 Tailstock set over should be half the difference between the finished diameters of the ends. That is $O=T \times L/2$ where T= taper per inch and L=length of work in inches.

Note: (A) Because most drawings give the taper in inches per foot of length, it may be easier to convert all dimensions to inches. (B) Be sure to zero the tailstock before resuming straight turning.

Boring a Tapered Hole

Boring a tapered hole involves setting the compound at the desired degree of taper and feeding the tool with the compound rest. Make sure the compound rest is set at half the degrees of the angle of the completed taper hole. You can also use a taper attachment to bore a tapered hole.

Chapter 13

Lathe Facing and Knurling

Before removing your work from the centers, face or square up the ends. On accurate work, especially where shoulders, bevels, and the like must be an accurate distance from the ends, do the facing before turning the shank. This also cleans the ends and machines the workpiece to accurate length.

When diameters are large, it's best to face with a special side tool that has a long, thin blade with a wide cutting edge. If you don't have one, use a right or left-hand facing cutter. Feed the tool from the center outward to avoid marring the lathe center (Figure 13.1).

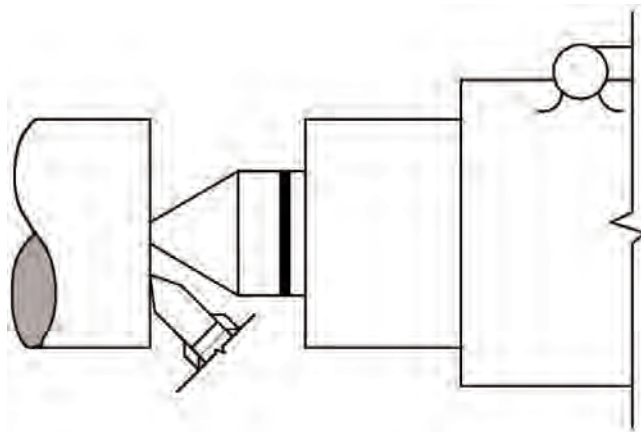

Figure 13.1 With a facing cutter, feed the tool from the center outward.

Facing Across the Chuck

When facing a stub-end workpiece held in the headstock chuck, the same rules apply. Chuck the stock, letting it protrude about an inch. Place a right-hand side tool (or a straight turning tool with a facing cutter) in the toolpost. Carefully adjust the cutting edge so it is exactly on center, then tighten it into the toolpost. If you don't do this, a small tit or projection will remain in the center of the stock and perhaps cause the center drill to run off center.

Start your lathe on the slowest speed. Bring the tool into cutting position against the center of the workpiece. Do not start with a heavy feed because the sfm increases rapidly as the cutter moves through increasing peripheries. One or two light cuts is usually enough to true up an end roughened by the hacksaw. After facing one end, reverse the workpiece and face the opposite end.

If you must finish the ends of the shaft, use a half-center (Figure 13.2). This lets you extend the tool across the entire face of the work.

To use the powerfeed for facing, place the speed selector into the desired position before

the lathe is turned on. Once the cutter has been positioned as per the above paragraph, move the crossfeed lever down. Pull the lever up at the end of the cut to stop the cutter travel.

Caution

Remember caution must be taken to not run the powerfeed past their limits of travel. As part of the normal operation, procedures, run each axis through the entire length of the proposed machining operation before engaging the powerfeed to assure there is sufficient travel to accomplish for the desired task. Failure to do so could result in running the power feed to the end of its mechanical limit. This is what is known as a "CRASH". A crash can cause damage to the work piece and severe damage to the machine.



Figure 13.2 With a half-center you can extend the tool across the entire face of the work.

Knurling

Strictly speaking, knurling is not a machining operation because no metal is cut. It is a forming operation in which patterned knurls are pressed into the work, depressing and raising the surface of the metal into a pattern. As with all other forming operations, your work can be no better than the pattern, your knurling no better than the knurls. Be sure the knurls are sharp, clean-cut (preferably hob-cut), and properly hardened.

To make a true, uniform knurl, maintain uniform pressure on both knurls. Select a self-centering knurling tool that equalizes pressure on the knurls automatically and is strong enough to withstand end and side thrusts. Operate the lathe at the slowest speed (160 rpm).

Knurling exerts extreme thrust against centers and bearings. You can lessen this thrust materially by feeding the knurling tool at a slight angle off from perpendicular to the line of the workpiece. This engages the right side of the knurl first (Figure 13.3).

Place a few drops of oil on the workpiece and knurling tool. Start the rolls of the knurling tool from the right-hand scribe line and feed them in until the knurl reaches a depth of 1/64". Then stop the lathe and inspect the work. If the knurl is not clear-cut, adjust the tool in or out as needed.

Use plenty of oil, lubricating both knurl and workpiece. Then start the lathe and engage the automatic feed, moving the knurls across the portion to be knurled. When you reach the left scribe line, force the tool into the work another $1/64$ ", reverse the lathe without removing the tool, and feed it back to the starting point. Feed both ways using the automatic longitudinal feed. Once across, each way, usually makes a good knurl.

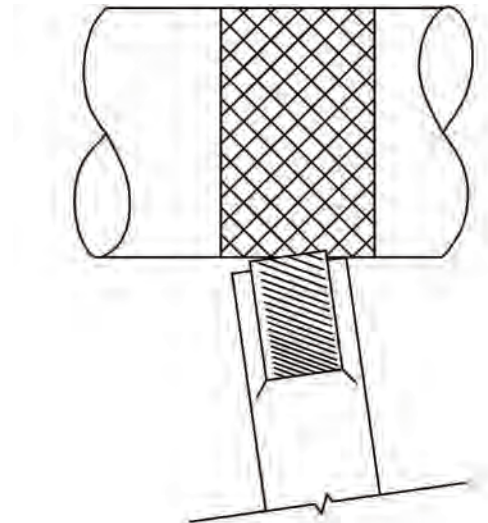

Figure 13.3 Feed the knurling tool at a slight angle off from perpendicular to the line of the work piece.

Chapter 14

Changing Gears

To change the gears on the MI-1220 XL, follow these steps. You will need a 10mm wrench, 6mm Allen wrench, screwdriver (to remove C clips), and pliers (to replace C clips).

1. Remove all C clips, nuts, and gears, starting with the A gear and ending with the D gear. With the 10mm wrench, loosen the B & C gearshaft in its bracket by turning the gearshaft counterclockwise (Figure 14.1). This lets the shaft slide freely along the bracket for easy gear removal and replacement.

Figure 14.1 Remove all C clips, nuts and gears.

- 2.** Select the proper A-D gear combination from the list outside the pulley box door.
- 3.** Use the Allen wrench to loosen the bolt at the bottom of the bracket assembly for full swing and easy gear replacement (Figure 14.1).
- 4.** Place the selected D gear on the D shaft, flange side in. Replace the spacer, washer and nut.
- 5.** Place the selected C gear, flange side in, on the B & C gearshaft.
- 6.** Place the selected B gear, flange side in, on the B & C gearshaft. Replace the C clip.
- 7.** Slide the B & C gearshaft until the C gear meshes properly with the D gear and tighten it with the 10mm wrench (Figure 14.2).

Figure 14.2 Slide the B and C gearshaft until the C gear meshes with the D gear.

- 8.** Place the selected A gear, flange side in on the A gearshaft and replace the C clip.
- 9.** Swing the bracket assembly until the A and B gears mesh. Hold the bracket assembly in place and tighten the bolt. Make sure the gears turn smoothly before engaging the powerfeed. You may need to make some adjustments.
- 10.** Engage the E gear between the C and D gears to reverse the leadscrew (Figure 14.3).

Figure 14.3 Engage the E gear between the C and D gears to reverse the leadscrew.

Chapter 15

Cutting Screw Threads

Threading Terms

Before beginning to cut threads, it's useful to learn the major terms used in thread cutting:

Pitch. Metric pitch is the distance from the center of a thread to the center of the next thread. To measure pitch in inches, measure an inch on a bolt and count the threads.

Pitch Diameter. This is the diameter of an imaginary cylinder superimposed on a straight screw thread, the surface of which would make an equal width of the thread and the spaces cut by the cylinder.

Lead. The lead is the distance a screw thread advances axially (as through a nut) with one complete revolution. The lead and pitch of a single thread are identical, but they differ on multiple threads (the lead of a double thread is twice its pitch; of a triple thread, three times its pitch).

Because thread cutting is so much a part of a machine work, anyone interested in building things of metal should master it. Threading requires a bit of patience and skill. Before trying to cut a thread on a workpiece, cut a few practice threads on odds bits of steel, iron and aluminium.

Built for thread cutting, The Midas 1220 XL cuts standard internal and external threads, as well as special threads. You may cut coarse or fine threads in a great range of threads per inch, in V or square shapes, in established profiles like Unified National, acme and metric. You can cut single threads or multiple threads that run concurrently along the shaft. You determine the type of thread by how you'll use the screw. Each thread form requires a different-shaped tool to cut or chase it.

Beginners will use the Unified National Standards most of the time, which is V-form thread slightly flat on top and at the root. Screw threads are usually referred to by pitch numbers, such as 18 or 24, meaning 18 or 24 threads per inch (tpi). The Midas 1220 XL cuts standard threads in pitches from 6 to 30 tpi and metric threads from 0.50 to 3mm.

Because the lathe spindle turning the work connects by gearing to the leadscrew (which moves the cutting tool along the lathe bed), a ratio exists between spindle speed in revolutions pre minute and cutting tool movement in inches. When you change the gearing, you change this ratio. For this reason you can cut threads of various pitches by changing both the change gears at the head of the lathe and the speed selection lever.

Thread charts inside the gearbox door show both inch and metric measures (Figure 7.2). The inch chart on the headstock shows the tpi from 6 to 30. The metric show the distance from thread crest 0.12 to 3 mm.

For right-hand threads, start the threading tool at the right end of the workpiece and feed it toward the headstock. For left-hand threads, reverse the leadscrew's rotation direction and feed the threading tool from left to right.

With practice, you can grind cutters to almost any profile. It is difficult, however, to sharpen such cutters without altering the cutting form, and almost every re-sharpening requires a complete regrinding of profile and clearance angles.

After turning the work to be threaded to the outside diameter of the thread and setting the gears for the desired thread, put a threading tool in the toolpost. Set it exactly on the dead center of the workpiece, using a center gauge as a guide.

To make sure your cutter is on dead center, place a credit card or shim between the cutter point and workpiece (Figure 15.1). When the tool is on dead center, the card or shim will remain vertical. With a credit card, there is no possibility of chipping the cutter as the workpiece and cutter come together.

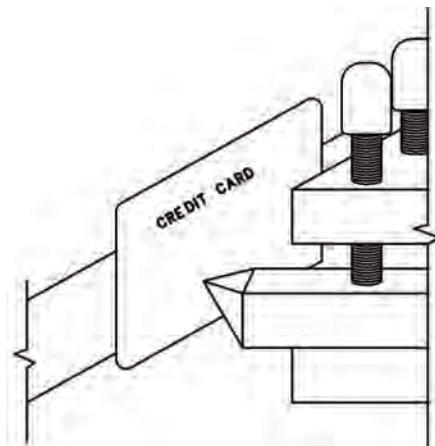
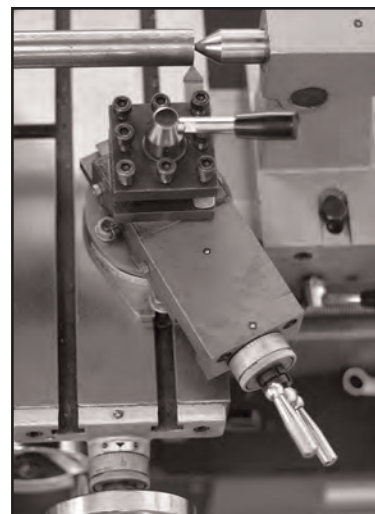
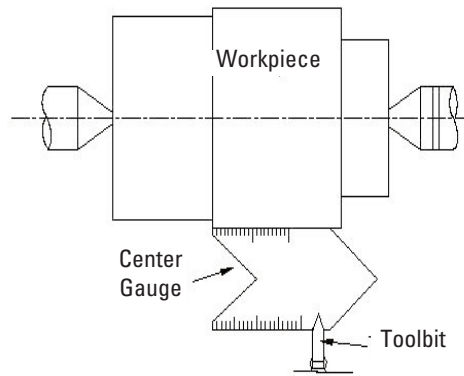

Figure 15.1 Check dead center with a credit card.

Set the compound perpendicular to the line of centers and rotate it 29-1/2 degree to the right (Figure 15.2). Place the thread gauge on the point of the threading tool and feed the tool toward the workpiece (Figure 15.3). Adjust the tool so the edge of the gauge is exactly parallel to the workpiece. A slip of white paper held below the gauge will help check the parallel of the gauge to the shaft and the fit of the toolpoint in the V of the gauge. Placing the threading tool perpendicular to the surface of the workpiece assures a true-form thread.

Figure 15.2 With the compound perpendicular to the line of centers, Rotate it 29 degree to the right.





15.3 Using a center gauge, set the threading tool at exactly dead center on the workpiece.

Cutting Right Hand Threads

Now you are ready to cut right-hand threads, First, advance the tool so it just touches the workpiece and turn the compound calibration back to zero. Then, using the compound feed, feed in the tool 0.002". Next, turn on the lathe and engage the half-nut lever by carefully turning it one-quarter turn to the right. Do not force it, and do not disengage I until you are completely done.

It is best to take a light, scratch cut first without using cutting fluid. After the tool runs the desired length, turn off the lathe and back the tool out of the work. Then reverse the motor to return the tool to the starting position. Using a screw-pitch gauge, check the thread pitch. The benefit of taking the light cuts is that you can correct any mistakes you might have made.

It's time to take the real cut now, so apply the appropriate cutting fluid to the workpiece. Feed the cross slide in 0.005-0.020" for the first run, depending on the pitch of the thread you have to cut. If you are cutting a coarse thread, start by taking a few heavy cuts. Reduce the cut depth for each run until it is about 0.002" at the final run. Zero the cross-feed calibration and make the second cut.

Continue this process until the tool is within 0.010" of the finished depth. Brush the threads regularly to remove chips. After the second cut, check the thread fit using a ring gauge, a standard nut or mating part, or a screw-thread micrometer. It is best to leave the workpiece in the chuck and not to remove it for testing.

After returning the workpiece to the setup, continue taking 0.00-0.002" cuts, checking the fit between cuts. When you thread the nut, it should go on easily but without end play. When you have the desired fit, chamfer the end of the thread (that is, take 45 degree cut off the end) to protect it from damage, Figure 15.4.

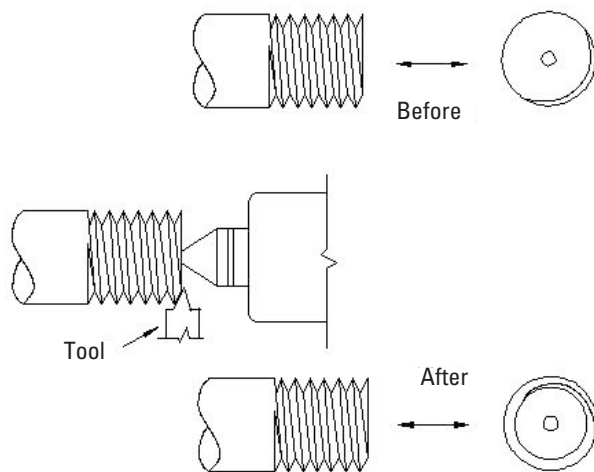

15.4 Chamfer the end of the thread to protect it from damage.

Cutting Left Hand Threads

Cut left-hand threads exactly as you cut right-hand threads, except this time feed the carriage toward the tailstock instead of away from it. Reverse the cutter clearances and grind the cutters back with a clearance angle on the left side. Swing the compound rest to the left rather than to the right.

Cutting Multiple Threads

Cut multiple threads (Figure 15.5) one at a time exactly as you cut single threads, except increase the lead to make room for succeeding threads (a double lead for a double thread, a triple lead for a triple thread, etc.). After completing the first thread, remove the work from the centers without loosening the lathe dog. Then put it back in the lathe with the tail of the lathe dog in the correct slot to index the work for the next thread. This work requires a faceplate with accurately position slots, uniformly spaced and equal in number to the number of threads to be cut.

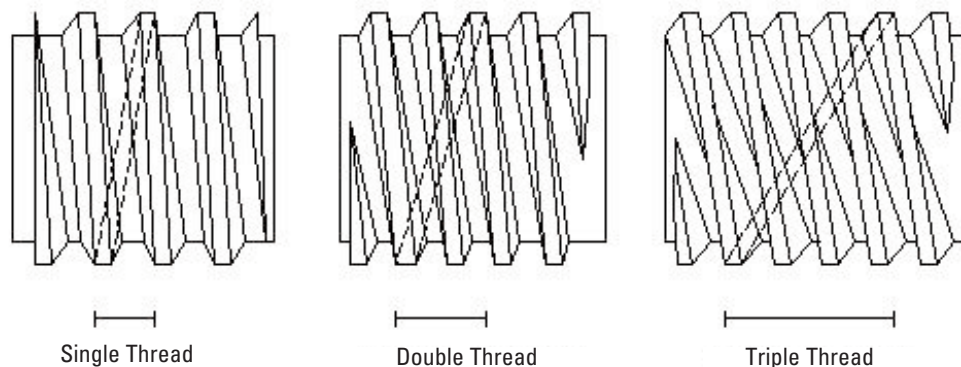

Figure 15.5 When cutting multiple threads, increase the lead to make room for succeeding threads.

What Not To Do When Cutting Threads

Do not disengage the half-nut lever. Do not shift the powerfeed speed lever. If you are cutting between centers don't remove the lathe dog until the tread is finished and tested, and don't disturb the spindle while the work is off the centers.

When you think the thread is finished and ready for testing, and only if absolutely necessary, remove the work from the center, leaving the lathe dog attached. Then test the thread. If it does not fit properly and you have to remove another chip or two, place the workpiece back in the centers exactly where it had been. Then remove the chips and test again. Repeat until are finished.

Finishing Off a Threaded End

After cutting a thread and before removing the threading tool, chamfer the end. This improves its appearance and removes sharp corners and burrs. It also aids the screws as it engages a nut or threaded hole.

Cutting Threads on a Taper

Cut threads on a taper the same as on a straight shaft, except in the setup of the tool. Set the threading tool at 90 degree to the axis of the taper, rather at 90 degree to its surface (Figure 15.6)

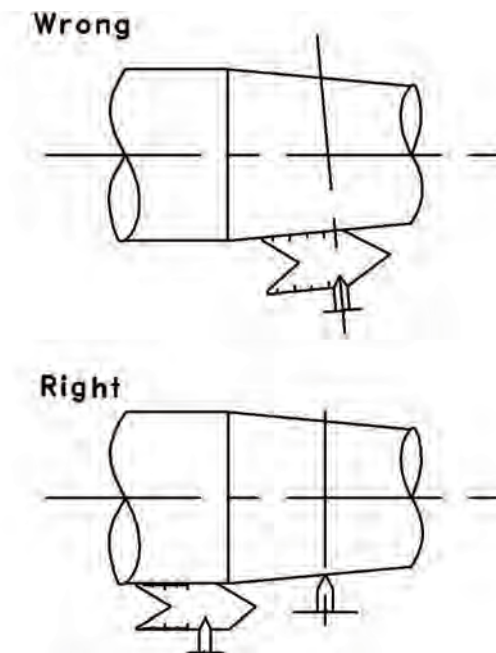

Figure 15.6 When cutting a thread on a taper, set the threading tool at 90 degree to the axis of the taper.

Chapter 16

Lathe Drilling and Boring

You can lathe drill on the MI-1220 XL in two ways, holding the drill stationary and revolving the workpiece, or holding the workpiece stationary and revolving the drill. Holding the drill stationary in a tailstock chuck gives a straighter hole (Figure 16.1).

Without changing setup and re-centering, the work is ready for any succeeding operations, such as boring and internal threading. In all lathe drilling operations, keep the drill sharp and properly ground. This is essential for obtaining a straight, accurate hole.

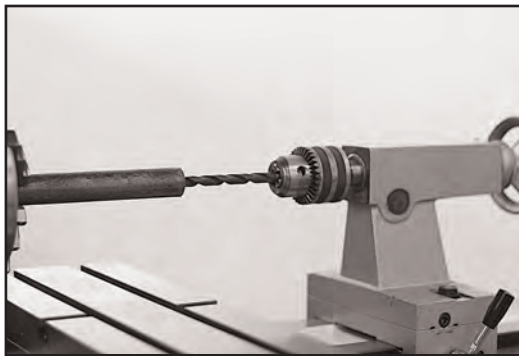

Figure 16.1 Holding the drill stationary in the tailstock chuck gives a straighter hole.

With HSS drills, operating speeds are not as critical as with carbon-steel drills. High speeds can quickly "burn" a carbon-steel drill. The number-of-feet-per-minute rule applies to drills even more than to other cutting edges because there is practically no air cooling of the point after it enters the hole. The larger the drill, the greater the number of peripheral feet cut per revolution. That is why you should use a slower drilling speed. If no drilling speed data are available, it's generally safe to run drills under 1/4" diameter at up to 750 rpm and drills up to 1/2" diameter at 500 rpm, with larger drills at proportionately slower speeds.

With the workpiece in the headstock and the drill in the tailstock chuck, feed the drill into the workpiece by advancing the tailstock ram. Do this by turning the tailstock handwheel. Make a locating center for the drill point, or even a countersunk center for large diameters, to keep the drill from creeping.

Reaming

When a hole must be accurate to 0.002" or less, drill it slightly undersized (0.010" to 1/64" on small diameters and 1/64" to 1/32" on holes 1" to 2" in diameter). Then ream it either by hand or in the lathe. Lathe reaming is usually done with solid reamers held in a tailstock chuck or with a taper shank that fits the tailstock ram in place of the tailstock center. Use slow speeds and feed the reamer slowly and evenly into the workpiece. Be sure the reamer teeth are free of burrs and chips.

Boring

Boring is internal turning, or turning from within. The diameter of the opening to be bored is often much smaller than its depth. Boring tools must therefore have relatively small diameters and still support a cutting edge projected at considerable distance from the toolpost or compound rest.

Boring tools consist of an extremely stiff, strong bar with a formed cutting end or a way to hold an HSS cutter or carbide insert. There are many sizes and types of boring bars. Choose the one that will give the stiffest possible bar at every depth and diameter and the greatest choice of cutters and cutter angles (ask a Smithy technician about the Smithy boring head combo package, #K99-125).

It is also wise to select tools with smooth-ended bars without a projecting nut or hardened edge that might mar the work (Figure 16.2). Most boring tools have only one cutting edge. There are double-end cutters, however, and they offer advantages in special instances. In grinding cutters, allow sufficient end rake to provide clearance from the internal diameter.



Figure 16.2 A tool with a smooth-ended bar won't mark the workpiece.

Except with cored castings, pipes, or tubing, begin by drilling a hole large enough to admit the end of the boring bar. Because the holes in cored castings often deflect boring bars from their true axis, you may want to chamfer or turn out a starting cut in the opening of the hole to be bored with a turning tool (Figure 16.3) before introducing the boring tool.

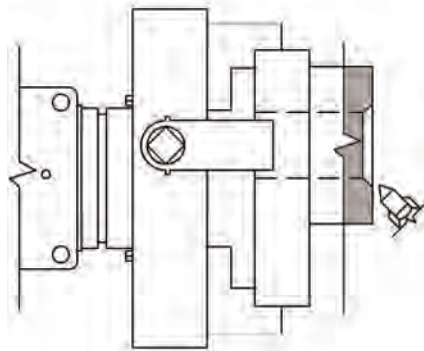

Figure 16.3 Chamfer a starting cut in the opening of the hole.

With the boring toolholder set up (in the toolpost or toolpost T-slot, depending on the type), select the largest-diameter boring bar whose cutter the bore will accept. Extend the bar from the holder just enough to reach the full depth to be machined and still allow

tool clearance. Except when using the adjustable boring tool (usually for very large diameter work), feed the bar into the hole, parallel to the holes axis. The cutting edge engages the work along a line in the mounted plane of the lathe centers with the bar positioned to give the cutter a top rake of approximately 14° from the radius at the cutting point (Figure 16.4). This takes into consideration the ground angle (top rake) of the cutter itself.

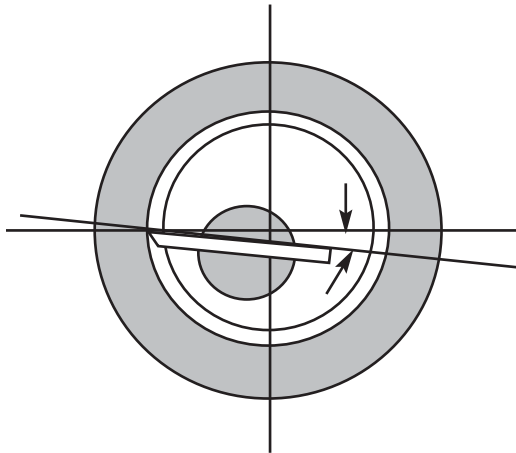

Figure 16.4 The cutting edge engages the work piece along a line in the mounted plane of the lathe centers.

For straight longitudinal cuts, you can hold the cutter close up, therefore more rigidly, if it's at a 90° angle to the bar. For machining ends of a bar, however, you need a boring bar that holds the cutter at an angle or angles so the cutter extends beyond the end of the bar (Figure 16.5). For maximum visibility, position the cutting edge at the near side, parallel to the centerline.

The rules that apply to external turning apply to boring as well, except-as noted earlier where the rake angles differ. The rake angles are governed by cutter type and bore diameter. Feeds must be lighter to keep the tool from springing. This is especially true when enlarging out-of-round holes, when you take several small cuts rather than one heavy cut.

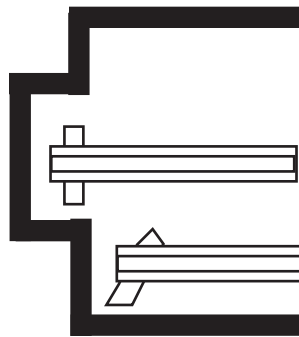

Figure 16.5 To machine ends of a bar, use a boring bar that angles the cutter so it extends beyond the bar.

After the last finish cut, it is common to reverse the feed and take one last, fine cut with the tool coming out of the work. This last cut, taken without movement of the cross-feed, avoids a slightly undersized hole because you compensate for any spring in the bar.

Cutting Internal Threads

Internal thread cutting is like external thread cutting, except you have the clearance restrictions and tool problems of boring. You use the same toolholders, but the cutters have thread forms and are fed at thread-cutting ratios of feed to spindle revolutions.

Another difference between boring and inside threading is the cutting angle at which the cutter approaches the workpiece. As with external thread cutting, the internal threading tool must engage the work on dead center and be held so the cutter coincides with the workpiece's center radius.

In squaring the cutter with the work, use a center gauge (Figure 16.6) or thread gauge. Internal cutters require greater end and side clearance, and cutter length is also restricted because internal thread cutters must have enough end clearance that for different thread types, the cutter lifts clear of the thread for removal (Figure 16.7). Before cutting an internal thread, bore the workpiece to the exact inside diameter.

Figure 16.6 Use a center or thread gauge to correct cutter alignment error when squaring the cutter with the workpiece.

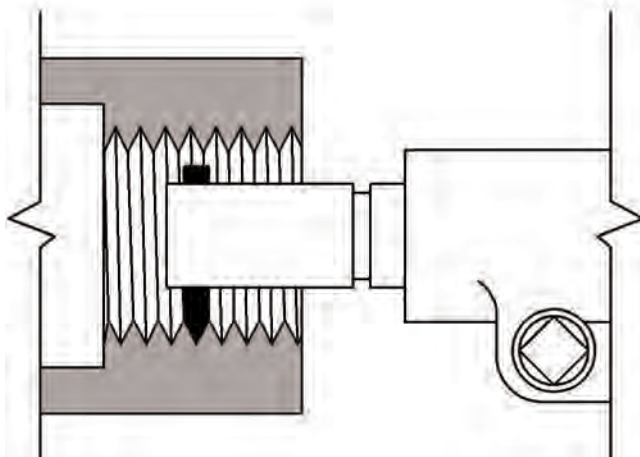

Figure 16.7 There must be enough end clearance for the cutter to lift clear of the thread.

Because the feed of successive cuts is toward, not away from, the operator, the thread-cutting set is reversed. Also, you must take lighter cuts because of the cutter's extension from the toolpost. Take an extra finishing cut without changing the setting of the compound rest.

Cutting Special Form Internal Threads

You can cut internal forms in all the thread forms used for external threads. There is only one factor that calls for special attention in cutting special-shaped internal threads: the difference of clearances between the nut and screw recommended for different thread types (Figure 16.8). If you don't have recommended clearances, it is safe to cut a nut thread (internal thread) 0.005" to 0.010" per inch larger in the screws outside diameter.

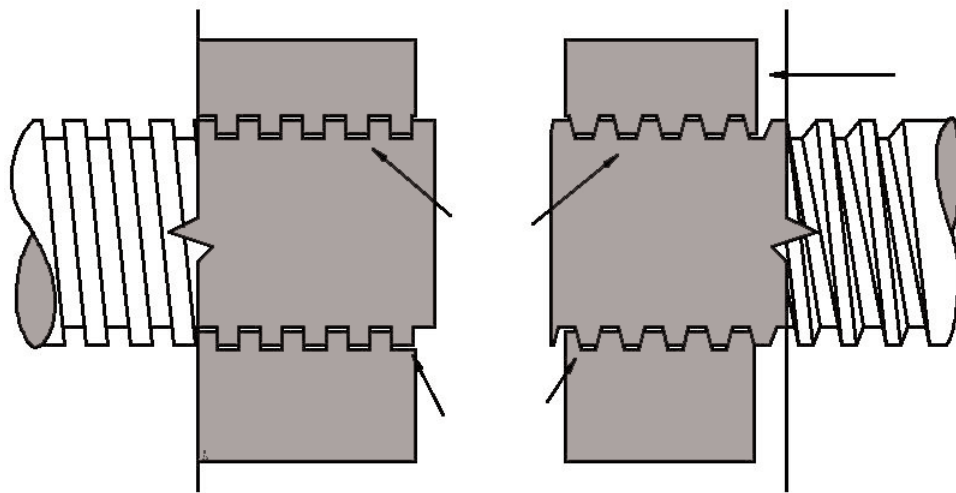

Figure 16.8 Use different clearances between nut and screw for different thread types.

Chapter 17

Cutting Off or Parting with a Lathe

You can cut off in a lathe only when holding one end of the work rigidly, as in a chuck. It is not practical for long workpieces held between centers because the workpiece is not supported closely with a rest and the free section is long enough to sag and pinch the blade. Cutting off requires a tight lathe without excess play in the spindle, compound, carriage, or toolpost. Looseness will almost certainly cause chatter. Cutting off also requires a narrow cutting edge with ample (5-10°) side clearance, which should feed into the work slowly to prevent hogging in. Once considered a difficult, costly operation, cutting off became much simpler with development of narrow tools with special cutoff blades (Figure 17.1).

The toolpost should hold the cut-off tool as close to the workpiece as possible, with the top of the blade on dead center and exactly perpendicular to the line of centers. Extend the blade only far enough to pass through the work-piece, just beyond its center. The tool should feed to the workpiece on exact center, slowly and evenly with the cross-feed. If the tool hogs in and the spindle stops rotating, turn off the motor and reverse the spindle by hand before backing the tool out with the crossfeed.



Figure 17.1 Specially designed tools like this one make cutting off easier.

Always set up the workpiece to cut off as close as possible to the headstock. If you must make a parting cut on a long shaft or on work between centers, don't complete the cut in the lathe. Finish the parting with a hacksaw and return it to the lathe for facing. Slow the spindle speed until you have a good feel for cutting off. Although lubricants and coolants are not essential on small-diameter workpieces, use them amply on deep cut-off work.

Chapter 18

Milling

In milling, one or more rotating cutters shape a workpiece held by a vise or other fixture. The cutters mount on arbors or at the end of the spindle on collets or adapters.

Machinists use mills to machine flat surfaces, both horizontal and vertical, and to make shoulders, grooves, fillets, keyways, T-slots, and dovetails. They can also make curved and irregular surfaces and machine accurate holes. Its variety of machining operations and high metal-removal rates makes the mill as important a tool as the lathe.

The millhead (Figure 5.1) rotates horizontally and moves vertically. A quill that moves in and out of the head carries the spindle.

You can move the table horizontally in two directions by turning the cross-slide and leadscrew handwheels (Figure 5.1). The cross-slide handwheel turns the table longitudinally (at right angles to the spindle axis); the long-feed hand crank moves it transversely (parallel to the spindle axis).

To raise and lower the millhead, release the lock lever and put the handle into one of the three holes in the black adjusting collar. To raise the millhead, turn it counterclockwise; to lower it, turn it clockwise.

To rotate the millhead, release the lock lever and push the millhead to the desired position.

Chapter 19

Workholding

The most common ways to hold a workpiece during milling are to secure it directly to the table via clamps or hold it in a vise (Figure 19.1). If you're making many similar workpieces, you may make a special fixture to hold them. Whatever method you use, hold the workpiece securely so it won't shift during machining and support it adequately to avoid swing.

Figure 19.1 Setting up in a vise is one of the most common ways to secure your workpiece.

Mounting to the Table

If you need to align the workpiece to the table, place it against stops that exactly fit the table's T-slots. Another way is to measure in from the edge of the table to the workpiece. Be sure the table and workpiece are clean and free of burrs. Another method is to use the face of the spindle plate, chuck or taistock as a quick reference surface.

Using a Vise

Vise sizes are designated by the width of the vise jaw in inches or millimeters. Plain and swivel vises range from 3 to 10" (76 to 254 mm). Tilting and universal vises range from 3-4" to 5" (76-102 mm to 127 mm).

The bases of many vises are fitted with keys-small steel blocks that fit into the milling table T-slot for quick alignment of the vise. Before mounting a vise, make sure the bottom is clean and smooth. If there are any nicks or burrs, remove them with a honing stone. Set up the workpiece securely and correctly, and fasten the vise tightly to the table.

Plain vises have a flanged base with slots that lets them bolt to the table with the jaw faces either parallel to, or at 90° to, the longitudinal table travel. Swivel vises have a swivel base that bolts to the table. They're marked with degree graduations that let you position their jaws at any angle without moving the base. Universal vises tilt up or sideways, or swivel. They hold workpieces machined at a double or compound angle. Tilting vises are like universal vises except they do not tilt sideways.

Using special fixtures. Clamp both workpiece and fixture securely in place. Be sure they are clean. Watch them carefully during machining; a loose fixture or workpiece can be disastrous.

Dividing Heads

Also called indexing heads, dividing heads attach to the table to hold workpieces between centers for machining surfaces, grooves, or gear teeth at precise distances apart.

The main parts of a dividing head are its head and tailstock. The tailstock holds the outer end of the workpiece. The head is more complex. When you turn its handle, a spindle rotates through a precisely machined gearing system. A chuck can attach to the spindle face, which is set at 90° to the handle (Figure 19.2). An indexing plate is set in from the handle. By counting how many turns of the handle it takes to turn the workpiece a certain number of degrees, you can make cuts at different angles. This is how to cut gears.

Figure 19.2 A chuck attaches to the spindle face of a dividing head.

Rotary Tables

A rotary table (Figure 19.3) is a precision worm and wheel unit that lets you cut gears, precision holes, and curved slots. Rotary tables mount vertically or horizontally to the table. T-slots secure the work piece. A typical rotary table is graduated in degrees and fractions.

The index plate in the rotary table has several circles of equally spaced holes into which the index crankpin fits. Although the hole circles are spaced equally, the number of holes varies in different circles, so you can get many different numbers of circumference divisions. You can buy sets of index plates for even more circumference divisions. Contact a Smithy technician for more information.



Figure 19.3 Rotary tables let you cut gears, precision holes, and curved slots.

Chapter 20

Holding Milling Cutters

There are several ways to hold milling cutters: in arbors, with collets and special holders, and in adapters.

Arbors

Arbors come in different sizes and lengths, with one end tapered to fit the bore in the end of the machine spindle. The Midas 1220 XL arbour, which has an MT3 taper, is driven by spindle. The arbor stays in place by means of a drawbar screwed into the end of the arbor from the top of the spindle. (Figure 20.1)

Figure 20.1 The arbor stays in place via a drawbar.

Take good care of your arbors. Store them in a rack or bin. If you won't be using them for several days or longer, oil them to prevent rusting, especially in damp weather.

Collets and Holders

Straight-shank end mills fit into spring collets (Figure 20.2) or end mill holders (Figure 20.3). Their precision-ground shanks go into the mill spindle. When you tighten a spring collet, its hole reduces and the collets grips the end of the end mill shank evenly. Tighten the end mill securely with the setscrew against the flat surface of the end mill, or it may slip out and damage the workpiece, the cutter or you.

Figure 20.2 Spring collets, which fit into the mill spindle, hold straight-shank end mills.





Figure 20.3 End mill holders also receive straight-shank end mills.

Adapters

Adapters mount various types and sizes of cutters on the spindle. Arbor adapters mount face mills on the spindle. Collet adapters mount end mills on the spindle. Taper-shank end mills mount in adapters that have holes with matching tapers. If the taper shank on the tool is smaller than the hole in the adapter, put a reducing sleeve into the adapter. Shell end mill adapters come in different sizes to accept different sized shell end mills.

To remove arbors or adapters held with a drawbar, follow these steps:

- 1.** Loosen the locknut on the drawbar about two turns.
- 2.** Hit the end of the drawbar with a dead-blow hammer, releasing the arbor or adapter from the spindle hole.
- 3.** Hold the arbour or adapter so it won't fall out of the spindle when the drawbar is removed.
- 4.** Unscrew the drawbar and remove the arbour or adapter.
- 5.** Your machine includes a tapered drift for removing tapers. Follow these steps:
- 6.** Remove the drawbar.
- 7.** Extend the mill spindle to expose the outer taper drift slot.
- 8.** Rotate the spindle to align outer and inner taper drift slots. You will be able to see the end of the adapter through both slots.
- 9.** Insert the drift in the slot.
- 10.** Holding the adapter with one hand, use a non marring hammer (rubber, dead-blow, or brass) to drive the drift into the slot. The taper on the tool will release and the adapter drop out.

Cutters mounted in the spindle must fit accurately. There are two ways to make sure they do. For small cutters, Fit the shank of the arbour that carries the cutter directly into the taper hole at the end of the spindle. A drawbar holds the arbour in place. For large cutters, bolt the cutter directly to the end of the spindle.

Chapter 21

Milling Cutters

Choose milling cutters for the type of cut, the number of parts, and the material. Rake angles depend on both cutter and work material. Clearance angles range from 3° to 6° for hard or tough materials to 6° to 12° for soft materials.

To determine the number of teeth you want, consider the following:

- There should not be so many teeth that they reduce the free flow of chips.
- The chip space should be smooth so chips don't clog.
- Don't engage more than two teeth at a time in the cut.

End Mill Cutters

End mill cutters cut on their ends and sides. They are either solid (cut from a single piece of material) or shell (separate cutter body and shank). They have two, three, four, or more teeth and may do right or left-handed cutting. Their flute twist or helix may also be right or left-handed. Solid end mills have straight or tapered shanks; shell end mill adapters have tapered shanks.

End mills machine horizontal, vertical, angular, or irregular surfaces in making slots, keyways, pockets, shoulders, and flat surfaces.

- *Two flute, or center-cutting, end mills* (Figure 21.1) have two teeth that cut to the center of the mill. They may feed into the work like a drill (called plunge milling), then go lengthwise to form a slot. Teeth may be on one end (single-ended) or both ends (double-ended).



Figure 21.1 Two-flute end mills have two teeth that cut the center of the mill.

- *Multiple flute end mills* have three, four, six, or eight flutes and may be single or double-ended. Multiple-flute mills are center cutting or non-center cutting. Don't use non-center cutting end mills for plunge milling.
- *Geometry forming end mills* form particular geometries. They include ball end mills, roughing end mills, dovetail end mills, T-slot cutters, key seat cutters, and shell end mills.

- *Ball end mills* (Figure 21.2) cut slots or fillets with a radius bottom, round out pockets and bottoms of holes, and do die sinking and die making. Four-fluted ball end mills with center cutting lips are available.



Figure 21.2 Ball end mills cut slots or fillets with a radius bottom.

- *Roughing end mills* remove large amounts of metal rapidly with minimum horsepower. They have three to eight flutes. Also called hogging end mills, they have wavy teeth on their periphery that provide many cutting edges, minimizing chatter.
- *T-slot cutters* cut T-slots. After machining a groove for the narrow part of the T-slot with an end or side mill, finish up with the T-slot cutter.
- *Keyseat cutters* cut keyseats for Woodruff keys (shaped like a half circle).
- *Shell end mills* (Figure 21.3) which mill wide, flat surfaces, have a hole for mounting on a short arbor. The center of the shell is recessed to provide space for screw or nut that fastens the cutter to the arbor. The teeth are usually helical, and diameters are as large as 6".



Figure 21.3 Shell end mills mill wide, flat surfaces and mount on arbors.

- **Insert-type end mills** use replaceable HSS or carbide inserts. Small end mills use two inserts; larger end mills, three or more.
- *Face milling cutters* start in size at 2" and have inserted teeth the periphery and face. Most of the cutting takes place on the periphery. They are similar to, but larger than, shell end mills.

Plain Milling Cutters

Plain milling cutters have teeth only on their periphery. Used to mill plain, flat surfaces, they may combine with other cutters to produce various shapes. They are cylindrical and come in many widths and diameters.

- *Light-duty plain cutters* for light cuts and fine feeds come in two forms. Narrow ones have straight teeth parallel to the cutter axis. Wide ones have helical teeth at a 25° angle. Features include ease of starting cuts, little chatter, and good surface finishes.
- *Heavy-duty plain cutters, or coarse-tooth cutters,* come in larger widths and have larger and fewer teeth. Strongly supported cutting edges and wide flutes provide strength and space for heavy chip removal. The helix angle of their teeth is 25° to 45°.
- *Helical plain milling cutters* have even fewer and coarser teeth with a helix angle of 45-60° or greater. These cutters are for wide, shallow profiling cuts on brass or soft steel.

Side Milling Cutters

Similar to plain milling cutters, side milling cutters also have teeth on one or both sides (Figure 21.4). The teeth on the periphery do most of the cutting; those on the sides finish the side of the cut to size. They cut grooves or slots and often work with other cutters to mill special shapes in one operation.



Figure 21.4 Side milling cutters are similar to plain milling cutter but they have teeth on one or both sides.

- *Plain side milling cutters* have straight teeth on the periphery and both sides. Side teeth taper toward the center of the cutter, giving side relief or clearance.
- *Half side milling cutters* have helical teeth on the periphery and one side. These cutters do heavy-duty face milling and straddle milling where teeth are needed on only one side. The side teeth are deeper and longer for more chip clearance.
- *Staggered-tooth side milling cutters* are narrow cutters with teeth alternating on opposite sides. There is less dragging and scoring and more space for chip removal. These cutters do heavy-duty operations.

Slitting Saws

Slitting saws do narrow slotting and cut-off operations.

- *Plain slitting saws* are thin, plain milling cutters with only peripheral teeth. The teeth are fine, and the sides taper slightly toward the hole, giving side relief.
- *Slitting saws* with side teeth are like side milling cutters and are for deeper slotting and cut-off operations normally done with plain slitting saws.
- *Staggered-tooth slitting saws* have peripheral teeth with alternate right and left-hand helix and alternate side teeth. They are for 0.2" and wider cuts and may do deeper cuts with standard feeds.
- *Screw-slotting cutters* are plain slitting saws with fine-pitch teeth that cut slots in screw heads. Their sides are straight and parallel and offer no side relief.

Angle Milling Cutters

Angle milling cutters, for such operations as cutting V-grooves, dovetails, and reamer teeth, come as single and double-angle cutters.

- *Single-angle cutters* have one angular surface. Teeth are on the angular surface and the straight side, and they usually have 45° or 60° angles.
- *Double-angle cutters* machine V-grooves. Those with equal angles on both faces usually have an included angle of 45°, 60°, or 90°.

Form-Relieved Cutters

Formed-tooth cutters machine surfaces with curved outlines. You can sharpen them without changing the tooth outline. Concave cutters mill convex half-circles; convex cutters cut concave surfaces.

- *Corner-rounding cutters* round outside corners.
- *Gear cutters* cut gear teeth.
- *Fluting cutters* cut flutes in reamers and milling cutters.
- *Formed-tooth cutters* come in right and left-hand styles and various special shapes.

Flycutters

With one or more single-point toolbits or cutters, flycutters (Figure 21.5) perform end milling even though they're not end mills. They take light face cuts from large surface areas. You must grind the toolbit properly to get correct rake and clearance angles. Grind

toolbits for flycutters as you grind lathe tools (Section Seven).

You can also use flycutters for boring.

Note: When the tool revolves, the cutting tool becomes almost invisible, so be careful.



Figure 21.5 Flycutters take light face cuts from large surface areas.

Using Cutting Fluid

Cutting fluids get rid of heat generated by the friction of the milling cutter against the workpiece. They also lubricate the interface between the cutting edge and the workpiece and flush chips away. You can apply fluid in a stream (flood) or as a mist.

We recommend cutting fluids for steel, aluminum, and copper alloys. With cast iron and steel, however, they tend to reduce the life of carbide tools, leaving tiny cracks along the cutting edge. Follow the advice of tool manufacturers to avoid tool failure. Materials such as cast iron, brass, and plastics are often machined dry. You can use compressed air to cool tools and clear chips away. When doing so, wear a face mask and protective clothing (Figure 21.6), and be careful to keep cast-iron dust from getting between the lathe and carriage ways.

Figure 21.6 When using compressed air, wear a face mask and protective clothing.

Tool Grinding

Sharpen cutting tools when they become dull, or extreme forces may build up at the cutting edge of the teeth, causing chipping or fracture. Dull cutters are also inefficient, and regrinding very dull cutters shortens their life considerably.

The form of the cutting edge and the clearance back of the cutting edge (land) affect cutter operation significantly. The angle formed by the land and a line tangent to the cutter at the tooth tip is the primary clearance. The angle between the back of the land and the heel of the tooth is the secondary clearance. Check both clearances and the rake.

Some cutters are sharpened on the periphery by grinding the land at a suitable angle. They include cutters with straight or spiral teeth, angular cutters, side milling cutters, face mills, end mills, and reamers.

You sharpen others by grinding the front faces of their teeth. Formed or relieved cutters, for example, have profiles that must be preserved. This category includes all sorts of formed cutters as well as cutters used for milling various regular and irregular shapes.

Chapter 22

Speeds and Feeds for Milling

Speeds

Milling cutting rates vary according to the machinability of the material being cut; whether cutting fluid is used and, if so, what kind; the type, size and material of the cutter and the coarseness of its teeth; and the amount of metal being removed. Cutting speed for milling is the distance the cutting edge of a tooth travels in one minute. If cutting speed is too high, the cutter overheats and dulls. If it's too low, production is inefficient and rough.

There is no exact right cutting speed for milling for a particular material (Table 22.1). Machinists usually start with an average speed, then increase or decrease it as appropriate. For light cuts, use the upper end. Use the lower end for heavy cuts and when you don't use cutting fluid.

Determining rpm. To set the spindle speed, you have to know the cutter rpm (revolutions per minute). For inch measurement, use the following formula:

$$\text{Rpm} = 12 \times \text{CS (fpm)} / \text{D''} \times \text{pi}$$

where **CS** = cutting speed, fpm = feet per minute, **D (mm)** diameter of the cutter in millimetres, and **pi** = 3.14 You can use an rpm chart for selected diameters of cutting tools at different cutting speeds.

To change speeds, set the belts according to Figure 6.12

Feeds

Set the direction of feed before you begin milling. Up milling, or conventional milling, is when the direction of feed is opposite to the direction of cutter rotation (Figure 22.2). Down milling, or climb milling, is when the direction of feed is the same as the direction of cutter rotation.

Up milling. In up milling, forces on the workpiece tend to pull it out of the vise or fixture holding it, so fasten it securely. These forces also push the workpiece away from the cutter, which eliminates backlash. Up milling is advised for milling cast iron, softer steels, and other ductile materials. In general, it's the best way to mill.

Down milling. Down milling usually produces good surface finishes because chips do not sweep back into the cut. Setups are more rigid, an advantage when cutting thin workpieces held in a vise or workpieces held in magnetic chuck. Down milling also produces straighter cuts. We recommend down milling when using carbide cutters because there is less wear on the cutting tool. In general, however, avoid it because of

the backlash problems associated with it.

Feed rates. Your feed rate should be as high as your machine, cutting tool, workholding method, and workpiece can tolerate while giving a good finish. Feed rate is usually given in inches per minute (ipm). You determine feed rate by the speed of the cutter in rpm and the number of teeth in the cutter.

There are many factors to consider in selecting the feed per tooth, and there is no easy formula to follow. Here are several principles to guide you:

- Use the highest feed rate conditions allow
- Avoid using a feed rate below 0.001" per tooth
- Harder materials require lower feed rates than softer materials
- Feed wider, deeper cuts more slowly than narrow, shallow cuts
- A slower feed rate gives a better surface finish
- Never stop the feed before finishing the cut

If you know the feed in inches per tooth, use this formula to calculate table feed rate in inches per minute (ipm):

$$\mathbf{Ipm = ipt \times N \times rpm}$$

Where **ipt** = inches per tooth, **N** = number of teeth in the milling cutter, and **rpm** = spindle speed of the milling machine.

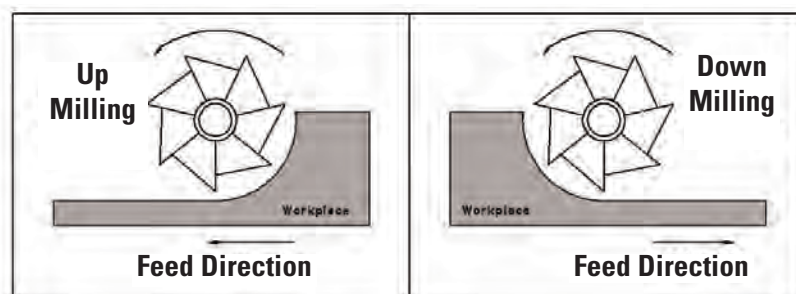

Figure 22.1 In up milling (left), the workpiece feeds into the cutter in the opposite direction of the cutter's revolutions. In down milling (right), the workpiece feeds into the cutter in the same direction as the cutter is turning.

Material		Brinell Hardness	High-Speed-Steel Cutters	Carbide Cutters
Free-machining low carbon steel resulphurized	1111	100-150	120-160	400-600
	1112	150-200	120-180	400-900
Free-machining low carbon steel leaded	10L18	100-150	100-225	250-500
	12L14	150-220	110-250	250-600
Plain low-carbon steels 1006		100-125	80-150	300-600
	1026	125-175	80-140	250-500
Plain medium-carbon steels	1030	125-175	80-140	250-500
	1095	175-225	60-110	225-400
Plain high-carbon steels	1060	125-175	70-120	250-450
	1095	175-225	60-110	225-400
Tool Steels	W1-W7	150-200	80-120	300-350
	H20-H43	200-250	40-85	175-300
	D1-D7	200-250	30-60	100-200
Stainless Steel	302	135-185	70-100	225-350
	430F	135-185	100-140	350-450
Gray Cast Iron	ASTM Class 20 Through Scale Under Scale	110-160	140-200	350-700
			130-225	400-800
Aluminum	Cold-drawn wrought alloys		500-800	1000-1800
Aluminum	Casting Alloy (as cast)		600-1000	1200-2000
Brass	360 free-cutting, cold-drawn		300-500	600-1000
Bronze	220 commercial annealed		80-140	180-275

Table 22.1 Recommended Cutting Speeds for Milling (fpm)

Chapter 23

Common Milling Operations

Milling Flat Surfaces

One way to mill a flat surface is by plane milling (Figure 23.1). Adjust the milling cutter vertically to give the needed depth of cut while the workpiece is held on the table and slowly feed it horizontally. Every tooth on the periphery of the cutter removes a chip every revolution. Milling wide, flat surfaces this way is called slab milling.

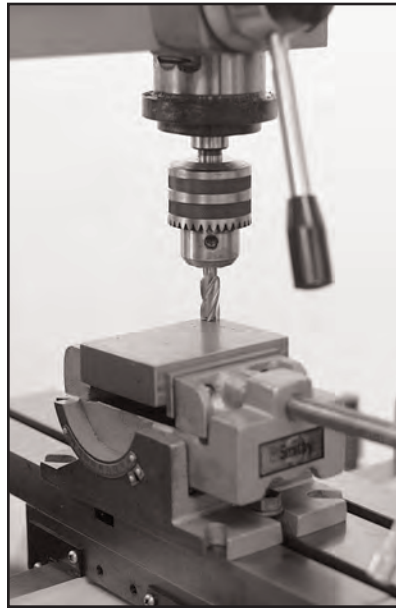

Figure 23.1 One way to mill a flat surface is by plane milling.

Another way to mill flat surfaces is by face milling. In this method, the cutter teeth operate at right angles to the cutter axis. Inserted-tooth face-milling cutters (Figure 23.2) face mill large surfaces.



Figure 23.2 Inserted tooth face milling cutters face mill large surfaces.

Bevels and chamfers are cut at an angle to the main work-piece surface. A bevel cut (Figure 23.3) goes from side to side, completely removing the perpendicular edge. A chamfer removes only part of the perpendicular edge.



Figure 23.3 A bevel cut goes from side to side, completely removing the perpendicular edge.

To cut bevels and chamfers, either move the workpiece into an angular cutter or hold the workpiece at the desired angle while moving it into a plain cutter or end mill. You may hold the workpiece in a vise or in a fixture held in a vise.

Squaring a Workpiece

To square the ends of a workpiece, use the peripheral teeth of an end mill. If you want to remove a lot of material, use a roughing end mill first, then finish to size with a regular end mill.

Plunge cutting is efficient for removing material quickly on low horsepower. Plunge the end mill a predetermined width and depth, retract it, then advance and plunge it again repeatedly. The maximum cutting force is in the machine's strongest (axial) direction.

Milling a Cavity

After laying out the outline of the cavity to cut, rough it out to within 0.030" of the finished size before making finish cuts. Use a center-cutting end mill for the starting hole.

Tapping

Drill a hole. Then remove the drill bit and put a tap into the chuck. By turning the chuck slowly by hand with slight downward pressure, you can get a perfectly threaded hole.

Chapter 24

Common Adjustments

Bevel Gear Adjustment

Occasionally you will have to adjust the bevel gears that drive the millhead. The adjustment is on top of the millhead support column (Figure 5.1). Using the sight hole on the back of the lathe head (Figure 5.5) will make the job easier. Remove the 20-mm plug on the back of the lathe head to access the sight hole.

There are two ways to reach the adjustment screws on top of the support column. Either unlock the millhead and lift it up off the machine or remove the four bolts under the drive pulley (Figure 5.7). Then lift the pulley and bearing seat from the millhead (Figure 6.2). There are six screws on top of the support column (Figure 24.1). To raise the bevel gear, loosen the three screws with heads and tighten the three without heads. To lower the bevel gear, loosen the three screws without heads and tighten the three with heads. When you are done, make sure all six screws are tight.

Figure 24.1 Use the six screws on top of the millhead support column to adjust the bevel gear.

To replace the bevel gear, remove the four socket-head capscrews below the black adjusting collar (Figure 6.2) and remove the millhead and support column from the lathe head. Remove the screw at the bottom of the bevel gear (Figure 24.2) and pull the gear from the shaft. Then reassemble it with the new gear. Before placing the millhead, adjust the bevel gear so it won't break as tighten the millhead onto the lathe head. Then adjust the bevel gear.

Figure 24.2 Remove the screw at the bottom of the bevel gear.

Millhead T-Key

The millhead has a T-key between the drive shaft and drive pulley. If you raise the millhead more than usual, this key may come partly or completely out. If it is out only partially, raise the millhead slightly. Then reach down inside the drive pulley with a screwdriver and push it back in. Align the keyway in the shaft and lower the millhead into place.

If the key fallen out, it is probably sitting on top of the column. Raise the millhead completely off of the machine and reinstall the key into the keyway on the pulley. Then replace the millhead.

Repositioning the T-key means inserting the shaft into a blind hole. If you put some heavy grease or Cosmo line on the back of the key, it will stay in place when you insert it. If you use your finger to put it into place, put a bit of the grease on your finger.

24.3 Lathe / Mill clutch

If the lathe clutch drop into neutral while turning, there will be too much gap between the jaws of the clutch. You must first determine how much gap there is. A spring-loaded steel ball in a detent in the jaw clutch holds the clutch in place. Pull on the clutch sleeve until you feel the ball drop into the detent and scribe a mark on the jaw clutch at the base of the bearing cap (Figure 24.3). Then pull the clutch sleeve out as far as possible and scribe another mark at the same place. The distance between these two marks is the amount of gap between the jaws.

Figure 24.3 Scribe a mark on the jaw clutch at the base of the bearing cap.

Bend back the tab on the lockwasher (Figure 24.4) and remove the spanner nut and lockwasher from the spindle. Remove the four screws from the bearing cap and pull on the clutch sleeve to remove the left jaw clutch and entire clutch assembly from the lathe spindle (Figure 24.5). Set it aside. Remove the key from the spindle, taking note of which keyway it is in. Remove the shaft sleeve from the spindle (Figure 24.6), shorten the sleeve by amount of gap, and reassemble the entire unit. The left jaw clutch will now slide on further, eliminating excess gap between the jaws.

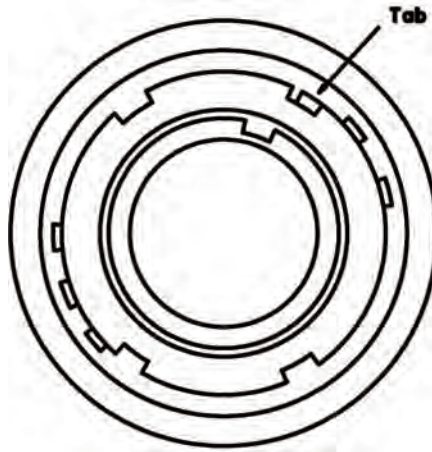

Figure 24.4 Bend back the tab on the lockwasher and remove the spanner nut and lockwasher.

Figure 24.5 Pull on the clutch sleeve to remove the left jaw clutch and entire clutch assembly from the lathe spindle.

Figure 24.6 Remove the shaft sleeve from the spindle.

Chapter 25

Troubleshooting

Powerfeed and Thread Cutting

Powerfeed does not move carriage

Cause

- Carriage locked
- Speed selector not engaged
- Sheared pin
- Gears not meshing or teeth missing
- Half-nut fully engaged

Solution

- Unlock carriage
- Select speed I or II
- Replace pin
- Check gears and mesh
- Keep half-nut engaged

Cut is not smooth

Cause

- Tool dull
- Tool not on center
- Tools not mounted tightly in post
- Cross-slide gibs to bed and base loose
- Gibs in toolpost loose
- Tool turret not tight
- Feed rate too fast
- Gears loose

Solution

- Sharpen or replace tool
- Center tool (shim, if needed)
- Remount tools
- Adjust gibs
- Adjust gibs in toolpost
- Tighten toolpost
- Install correct gears
- Tighten gears and posts

Thread is not smooth

Cause

- Too dull
- Tool not centered
- Tools not mounted tight in post
- Cross-slide gibs to bed and base loose
- Gibs in compound loose
- Tool turret not tight
- Gears loose

Solution

- Sharpen tool
- Center tool
- Remount tools
- Adjust gibs
- Adjust gibs
- Tighten toolpost
- Tighten gears and posts

Tool is not cutting “on thread”*Cause*

- Half-nut fully engaged

Solution

- Keep half-nut engaged

Carriage and Milling Table**Table won’t move***Cause*

- Table locks engaged
- Gibs too tight
- Half-nut not engaged

Solution

- Loosen locks
- Loosen gibs
- Keep half-nut engaged

Horizontal movement in cross-slide table*Cause*

- Carriage gib improperly adjusted
- Table gib improperly adjusted

Solution

- Adjust carriage gib
- Adjust table gib

Vertical movement in cross-slide table*Cause*

- Carriage gib improperly adjusted
- Table gib improperly adjusted

Solution

- Adjust carriage gib
- Adjust table gib

Carriage moves smoothly in only one direction*Cause*

- Debris on way or gib
- Burr on gib
- Gib improperly tensioned
- One or more wipers mounted too low

Solution

- Remove debris
- Remove burr with fine file
- Loosen gib and re-tension
- Reposition wiper(s)

Cross-slide handwheel turns during cutting operations*Cause*

- Cross-slide brass nut worn
- Carriage locks not tight
- Gibs too loose

Solution

- Tighten or replace brass nut
- Tighten carriage locks
- Readjust gibs

Too much backlash in the cross-slide

Cause

- Loose screw
- Loose brass nut
- Worn brass nut
- Too much space between bearing 1 and dial

Solution

- Tighten screw, review how to eliminate backlash
- Put a shim between the stud on the nut and the side of the hole
- Replace the brass nut or adjust screw at end of nut
- Add shim washers

Lathe Turning

Clutch drops into neutral while turning

Cause

- Too much gap between the jaw clutch and the left jaw clutch

Solution

- Shorten the shaft sleeve

Cut is rough

Cause

- Tool dull
- Tool not ground properly
- Tool at wrong angle
- Tools not held tightly
- Wrong cutter for material
- Cutting speed incorrect

Solution

- Sharpen or replace tool
- Regrind tool
- Correct tool position
- Tighten toolholder
- Use correct cutter
- Increase or reduce speed

Work has unwanted taper

Cause

- Work improperly aligned
- Debris in spindle, setup, or tools
- Offset tailstock incorrectly positioned
- Spindle out of alignment

Solution

- Realign centers on work
- Clean and reset setup, work or tool
- Correct position of tailstock
- Tighten taper bearings to return to alignment, replace spindle bearings

Machine vibrates

Cause

- Work mounted wrong

Solution

- Remount work

- | | |
|--|--|
| <ul style="list-style-type: none"> • Speed too high • Too much pressure at tailstock | <ul style="list-style-type: none"> • Reduce speed • Reduce pressure and increase lubrication |
|--|--|

Works stops turning but machine continues to run

Cause

- Work not mounted securely
- Tools forced into work
- Belts slipping

Solution

- Remount work
- Reduce force on tools
- Tension belts, use belt dressing or replace belts

Diameter of work is not consistent

Cause

- Too much flex in workpiece
- Too much flex in compound rest, cross-slide or carriage

Solution

- Use a follow rest
- Tighten gibs, clean ways

Too much backlash in the compound

Cause

- Loose spanner nuts
- Worn nut

Solution

- Tighten spanner nuts
- Replace nut

Machine slings oil from behind the chuck or in belt box

Cause

- Oil reservoir overfilled
- Worn oil seal

Solution

- Check oil level
- Replace felt in seal

Milling

Tool chatters

Cause

- Gibs too loose on cross slide, compound or carriage
- Unused feeds not locked
- Millhead not locked
- Quill too loose

Solution

- Readjust gibs
- Lock all axes but the one moving
- Lock millhead
- Tighten quill lock

- Tool not on center
- Improper tool shape, tool dull

- Center tool
- Reshape, sharpen or replace tool

Depth of cut is not consistent

Cause

- Quill moving
- Setup wrong

Solution

- Lock quill
- Make sure setup is parallel to table

Drilling

Hole is off center or bit wanders

Cause

- Bit dull
- Bit not mounted correctly in chuck
- Bit bent
- Chuck loose in spindle
- Drawbar not secured
- Debris on spindle
- Bearing loose or worn
- Cutting too fast
- Incorrect bit

Solution

- Use sharp bits
- Remount tool
- Replace bit
- Remount chuck on arbor
- Tighten drawbar
- Clean debris and arbour and remount tool
- Tighten or replace bearings
- Reduce speed
- Use correct bit

Entrance hole is out of round

Cause

- Bit dull
- Incorrect drill bit

Solution

- Use sharp bits
- Use correct bit

Bit turns erratically or stops

Cause

- Bit fed into work too fast
- Belt slipping

Solution

- Reduce feed rate
- Reduce feed rate, re-tension belts

Chuck is difficult to tighten or loosen

Cause

- Chuck sticking

Solution

- Apply lubricant

- Debris in chuck

- Clean chuck

Chuck wobbles

Cause

- Chuck loose on arbour
- Drawbar not tight

Solution

- Clean arbour and remount
- Clean spindle and replace drawbar

Drive System

Turn on machine and nothing happens

Cause

- Machine unplugged
- Loose electrical connections

Solution

- Plug in machine
- Tighten wiring connections

Motor and pulleys turn, but not lathe or mill

Cause

- Lathe mill clutch is in neutral

Solution

- Pull the clutch sleeve all the way out (lathe) or push it all the way in (mill)

Pulleys turn and clutch is engaged but the mill does not turn

Cause

- T-key missing
- Bevel gears stripped or broken
- Bevel gear out of adjustment

Solution

- Replace key
- Replace bevel gear
- Readjust bevel gear

Chapter 26

MI-1220 XL Specifications

General Dimensions

Length	42"
Width	20"
Height	37"
Shipping Weight	530 lbs
Machine Weight	419 lbs
Crate Size	43-1/2" x 22-1/2" x 36-1/4"
Footprint	42" x 30"
T-Slot Size	7/16"
Accuracy	+/- 0.001"
Powerfeed (X-Axis)	Yes
Powerfeed (Y-Axis)	No
Powerfeed (Z-Axis)	No
Table Size	5-7/8" x 16-3/4"
Threading Dial	No

Lathe Specifications

Distance Between Centers	20"
Dial Calibration on Crossfeed	.002"
Dial Calibration on Toolpost	.002"
Dial Calibration on Leadscrew	.002"
Dial Calibration on Longfeed Rack	N/A
Dial Calibration on Tailstock	.002"
Feed Rates	.003-.006" (X-axis)
Headstock Taper	MT4
Lathe Chuck Bore	1.17"
Lathe Chuck Diameter	5"
Lathe Chuck - Max. diameter work piece	5"
Lathe Chuck - Min. diameter work piece	1/8"
Lathe Chuck Mount	Bolt-On
Lathe Chuck Type	3 Jaw Self Centering
Spindle Bore	1.03"
Spindle Speeds	Six (160-1600 RPM)
Swing Over Bed	12"
Swing Over Work Table	6-3/4"
Tailstock Offset	19/32"
Tailstock Taper	MT3
Tailstock Barrel Travel	2"
Threads-Inch	SAE 6-120 TPI
Threads-Metric	0.5 to 4 mm
Toolpost Travel	3-1/4"
Toolbit Size	1/2"

X-Axis Travel (w/tailstock installed)	15"
Y-Axis Travel	7-3/8"

Mill Specifications

Column Diameter	3-1/8"
Dial Calibration Drill-Coarse Feed	0.042"
Dial Calibration Mill-Fine Feed	0.042"
Drawbars Size (included)	12 mm, 3/8"
Drill Chuck Size (included)	1/2"
Drill Chuck Arbor Size (included)	MT3/JT33
Feed Rates	N/A
Head Rotation	360 Degrees
Head Travel	3-1/4"
Quill Diameter	2-3/4"
Quill Travel	3-5/8"
Spindle Center to Front of Chuck	3-3/16"
Spindle Center to Lathe Spindle Flange	5-1/2"
Spindle Center to Support Column	6-7/8"
Spindle to Table Distance(min-max)	6-1/4" - 13"
Spindle Speeds	12 (125-1600 rpm)
Spindle Taper	MT3
Tool Size Limits	1"
X-Axis Travel	6-5/8"
Y-Axis Travel	7-3/8"

Electrical

Amperage	11 amps
Horsepower	3/4 hp
Motor Type	A/C
Phase	Single
Voltage	110 Volts A/C

Chapter 27

Removing the Apron from the MI-1220 XL

Please have the manual at hand when working on the machine and when calling Smithy Co. for assistance. The apron is removed with the leadscrew still installed in the apron. This prevents the worm gear inside the apron from falling out off place.

Procedure:

- 1.** Remove the taper pin from the left end of the lead screw. This is a tapered pin and must be driven out from the small end.
- 2.** Remove the 2 screws from the right support of the lead screw and remove the support.
- 3.** Slide the tail stock off the machine.
- 4.** Remove the 2 screws from the front support of the crossfeed screw and slide the table back away from the front support far enough to be able to get the 4 screws holding the apron on.
- 5.** Remove the 4 screws that hold the apron to the carriage. The apron will drop down far enough to allow the apron gears to disengage from the toothed rack on the front of the machine and let the entire carriage to move freely left and right.
- 6.** The apron will not drop down far enough to come free from the carriage because of the two taper pins that would go through the carriage into the apron.
- 7.** Loosen the two carriage gib adjustment screws to allow easier removal of the carriage. With the assistance of a helper, slide the carriage, table and apron assembly off the end of the machine just enough to be able to remove the apron then put the carriage back onto the machine.
- 8.** Tap the two taper pins up and out of the carriage to allow the apron to be reinstalled without removing the carriage from the machine.
- 9.** To remove the leadscrew, turn the apron upside down and remove the cover. Pull the leadscrew from the apron and watch the position of the worm gear so you will know how to reinstall it properly. There is also a key inside the worm gear. Make sure the key is in place when reinstalling the gear and screw shaft.
- 10.** Reverse the above procedure for assembly.

Chapter 28

Changing the Lateral Drive Shaft in the MI-1220 XL Apron

Please have the manual at hand while working on the machine and when calling Smithy Co. for assistance.

Procedure:

- 1.** Remove the apron and leadscrew as per instructions from Chapter 27.
- 2.** Gears 29 and 30 are attached together and are removed as one piece. There are 2 setscrews in the narrow space between 29 and 30 that need to be removed. These are not shown in the manual. They hold the 2 gears onto the 28 gearshaft.
- 3.** Remove setscrew 32 that locks the 28 shaft into the main casting 24.
- 4.** Drive the 28 gearshaft out from the front to back.

Assembly Procedure:

- 1.** Coat all moving parts with a liberal amount of a medium weight grease such as Lubraplate.
- 2.** Make sure the key 27 is in the gearshaft 28. Slide the shaft into the apron while installing gears 29, 30 and 25 as the shaft is slid into place.
- 3.** Install setscrew 32 to lock the gearshaft in position. Install the 2 setscrews into the space between 29 and 30 to lock these two gears into the gearshaft.
- 4.** Install the apron according to the apron removal sheet.

Mill / Drill Head

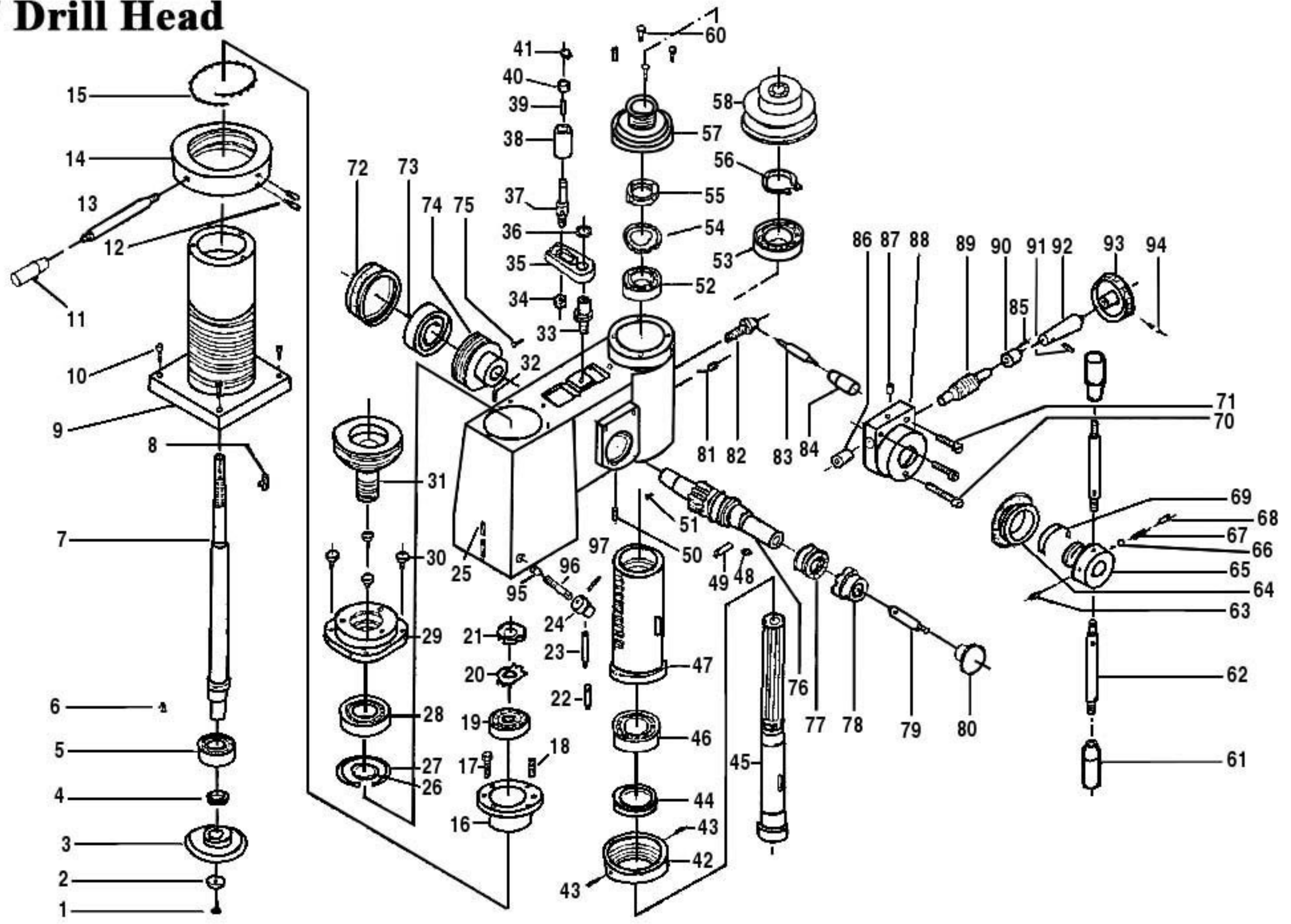

Mill / Drill Head

Diagram Number	Part Number	Reference Number	Description
1	S11663	M5x14 GB68	Countersunk-Head Screw
2	C30207	28 GB891	Retaining Ring
3	C30001		Bevel Gear
4	S18591		Washer
5	S20380	205	Radial Ball Bearing
6	S21500	6x12GB1096	Key
7	C30221		Drive Shaft
8	S21261	5x20 GB1096	T-Key
9	C30222	M10x25 GB30	Millhead Support Column
10	S12611	M10x25	Socket-Head screw
11	C30019		Knob
12	S11978	M6x16	Setscrew
13	S30020	C30020	Handle Lever
14	C30223		Adjusting Collar
15	C30224		Ball Bearings
16	C30225		Bearing Seat
17	S11994	M6x20	Cheese-Head Bolt

Diagram Number	Part Number	Reference Number	Description
18	S11978	M6x16	Setscrew
19	S20290		Bearing
20	C30208		Lockwasher
21	C30209		Spanner Nut
22	C30019		Knob
23	C30095		Handle
24	C30094		Base
25	C30007		Millhead
26	S23260		Snap Ring
27	S23440		Snap Ring
28	S20520		Bearing
29	C30226		Bearing Set
30	S11690	M5x20	Hexagon-Head Bolt
31	C30227		Pulley
32	S12282	M8x18	Setscrew
33	C30001		Fulcrum
34	S18125	M8	Hexagon Nut

Mill / Drill Head

Diagram Number	Part Number	Reference Number	Description
35	C30009		Tension Pulley Arm
36	S23170	15 GB894	External Snap Ring
37	C30010		Axle
38	C30011		Sleeve
39	C30012	2.5x24 GB304	Roller
(37-41)	C39004		Roller Assembly
40	C30205		Spacer Ring
41	S23075	10 GB894	External Snap Ring
42	C30013		Bearing Cap
43	S11602	M5x5 GB71	Cone-Point Setscrew
44	C30014	45	Felt Collar
45	C30015		Drill/Mill Spindle
46	S20500	D2007107	Tapered Roller Bearing
47	C30016		Spindle Sleeve
48	S21560	6x15 GB1096	Plain Parallel Key
49	S22060	5x28 GB119	Straight Pin
50	S12278	M8x16 GB78	Setscrew

Diagram Number	Part Number	Reference Number	Description
51	S11315	M4x6 GB67	Round-Head Setscrew
52	S20410	2007106	Tapered Roller Bearing
53	S20560	108	Radial Ball Bearing
54	C30210	30 GB858	Lockwasher
55	C30211	M30x1. GB812	Round Nut
56	S23320	40 GB894	External Snap Ring
57	C30017		Bearing Seat
58	C30018		Large Pulley
60	S11690	M5x20 GB30	Hexagon-Head Bolt
61	C30019	M 10x50 GB4141	Knob
62	C30020	M10x100 GB4141	Handle Lever
63	S11952	M6x12 GB71	Cone-Point Setscrew
64	C30021		Calibrated Dial
65	C30022		Handle Seat
66	C30199	5 GB308	Steel Ball
67	C30200	0.5x15	Spring

Mill / Drill Head

Diagram Number	Part Number	Reference Number	Description
68	S11938	M6x8 GB73	Flat-Point Setscrew
69	C30201		Spring
70	S11761	M5x50	Capscrew
71	S12021	M6x30 GB70	Capscrew
72	C30023		Spring Cap
73	C30024	0.8x20x1000	Spring Flat
74	C30025		Spring Seat
75	S11315	M4x6 GB67	Round-Head Setscrew
76	C30026		Gearshaft
77	C30027		Wormgear
78	C30028		Clutch Sleeve
79	C30029		Small Shaft
80	C30030		Cone Knob
81	S12268	M8x14 GB75	Dog-Point Setscrew
82	C30031		Handle Seat
83	C30032	M6x40 GB4141	Handle Lever
84	C30033	M6x36 GB4141	Knob
85	S11642	M5x10 GB71	Cone-Point Setscrew

Diagram Number	Part Number	Reference Number	Description
86	C30034		Sleeve
87	C30035	8 GB1155	Oilcup
88	C30036		Worm Seat
89	C30037		Wormgear
90	C30034		Sleeve
91	S22110	3x16 GB117	Taper Pin
92	C30038		Joint Lever
93	C30039		Handwheel
94	S22130	3x18 GB117	Taper Pin
95	C30548		Bushing
96	C30465		Stud
97	S22140	3x22	Taper Pin

Lathe Head

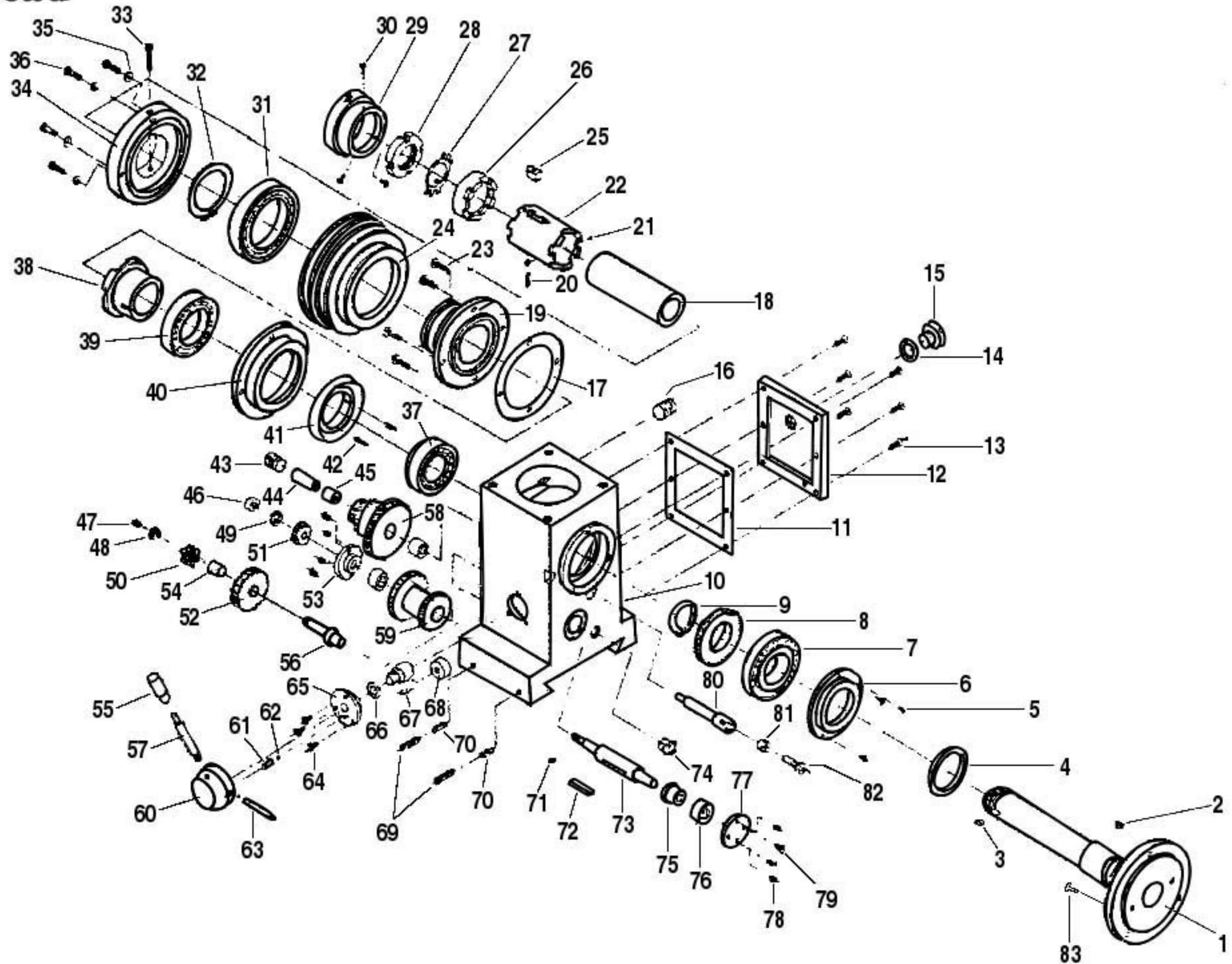

Lathe Head

Diagram Number	Part Number	Reference Number	Description
1	C30097		Lathe Spindle
2	S21509	C6x4x12 GB1567	Thin Flat Key
3	S21499	C6x4x10 GB1567	Thin Flat Key
4	C30014	47	Felt Collar
5	S11333	M4x8 GB819	Phillips Oval-Head Screw
6	C30098		Mainshaft Bearing Oil Seal
7	S20550	D20718 GB297	Tapered Roller Bearing (Include outside bearing seat)
8	C30099	50 Tooth	Gear
9	S23290	36 GB894	External Snap Ring
10	C30100		Lathe Head
11	C30101		Gasket
12	C30102		Transmission Cover
13	S11673	M5x16 GB68	Countersunk-Head Screw
14	S24400	30x20x2	O-Ring
15	C30103	M20x1.5 Q/ZB20	Oil Port Plug
16	S13198	M20x20 GB77	Flat-Point Setscrew
17	C30104		Gasket

Diagram Number	Part Number	Reference Number	Description
18	C30105		Shaft Sleeve
19	C30106		Pulley Seat
20	C30107	0.6x5x15 GB2089	Spring
21	C30199	5 GB308	Steel Ball
22	C30108		Jaw Clutch
23	S11994	M6x20 GB65	Fillister-Head Screw
24	C30109		Spindle Pulley
25	S21950	12x14 GB1096	Plain Parallel Key
26	C30110		Left Jaw Clutch
27	C30217	35 GB858	Lockwasher
28	C30218	M35x1.5 GB812	Round Nut
29	C30111		Clutch Sleeve
30	S11343	M4x10 GB820	Phillips Pan-Head Screw
31	S20680	113 GB276	Single-Row Ball Bearing
32	S23410	65 GB894	External Snap Ring
33	S11724	M5X30GB894	Cheese-head Screw
34	C30112		Bearing Cap

Lathe Head

Diagram Number	Part Number	Reference Number	Description
35	S18075	5 GB93	Spring Washer
36	S11684	M5x18 GB65	Cheese-Head Screw
37	S20500	2007107 GB297	Tapered Roller Bearing
38	C30113		Right Jaw Clutch
39	S20630	110 GB276	Single-Row Ball Bearing
40	C30114		Bearing Seat
41	C30115		Bevel Gear
42	S11342	M4x10 GB71	Cone-Point Setscrew
43	S13198	M20x20 GB77	Flat-Point Setscrew
44	C30116		Sleeve
45	C30117		Oil-Impregnated Bearing
46	S18125	M8 GB52	Hexagon Nut
47	C30050	6 GB1155	Oilcup Zerk (Z40024)
48	S23080	9 GB896	E-Shaped Snap Ring
49	S18135	8 GB93	Spring Washer
50	C30118		Spline Housing

Diagram Number	Part Number	Reference Number	Description
51	C30119	24 Tooth	Gear
52	C30153	50 Tooth	Gear
53	C30120		End Cap
55	C30054	BM8x40 GB4141	Knob
56	C30121	(C30121A) New	Shaft
57	C30053	BM8x50 GB4141	Handle Lever
58	C30122		Triple Gear
59	C30123		Duplex Gear
60	C30124	12x50 GB4141	Handle Seat
61	C30125	0.8x5x25 GB2089	Spring
62	C30126	65 GB308	Steel Ball
63	S22185	5x50 GB117	Taper Pin
64	S11643	M5x10GB68	Countersunk-Head Screw
65	C30127		Location Plate
66	S24200	15x2.4 GB1235	O-Seal Ring
67	C30128		Shifting Yoke

Lathe Head

Diagram Number	Part Number	Reference Number	Description
68	C30129		Loose Piece
69	S12618	M 10x25 GB79	Setscrew
70	S22420		Locking Pin
71	S21110	4x8 GB1096	Plain Parallel Key
72	S21320	5x40 GB1096	Plain Parallel Key
73	C30130		Output Shaft
74	C30131	10 JB283	Oil Level Indicator
75	C30132		Spacing Sleeve
76	C30133		Oil-Impregnated Bearing
77	C30134		End Cap
78	S11618	M5x6 GB73	Flat-Point Setscrew
79	S11643	M5x10 GB68	Countersunk Screw
80	C30135		Middle Shaft
81	C30136		Shaft Nose
82	S12314	M8x25 GB822	Cheese-Head Screw
83	S12290	M8X20	Head Hex Bolt
54	C30553		Spacer /Sleeve

Diagram Number	Part Number	Reference Number	Description
	C30532	5"3 Jaw Chuck	Key Replacement

Spindle / Pulley Cover

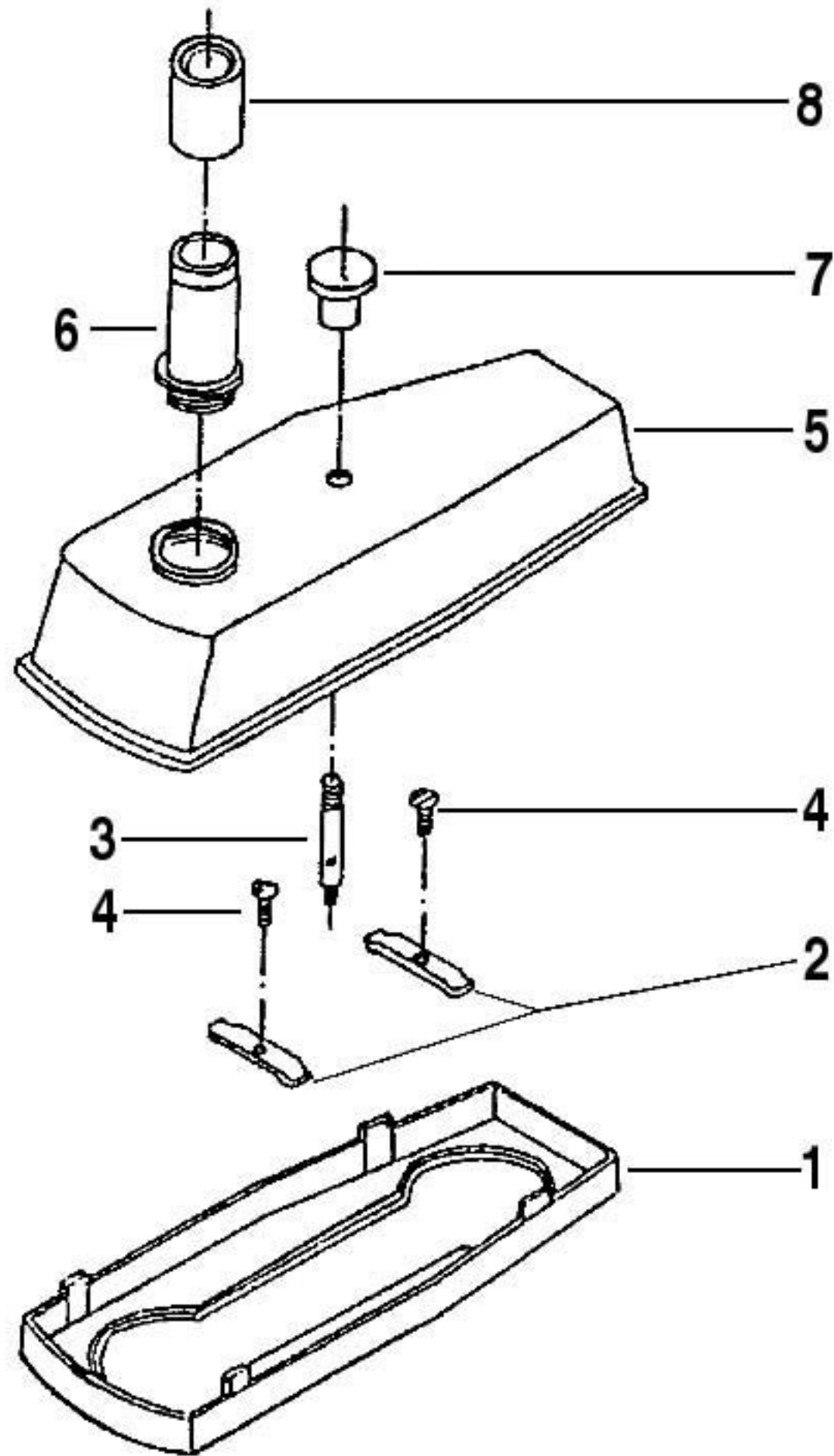

Spindle / Pulley Cover

Diagram Number	Part Number	Reference Number	Description
1	C30040		Pulley Shell Base Cover
2	C30041		Plate
3	C30042		Stud
4	S11965	M6x14 GB67	Round-Head Screw
5	C30043		Pulley Shell Top Cover
6	C30609		Spindle Cover
7	C30030		Cone Knob
8	C30610		Spindle Top Cover

Bed and Gear / Powerfeed

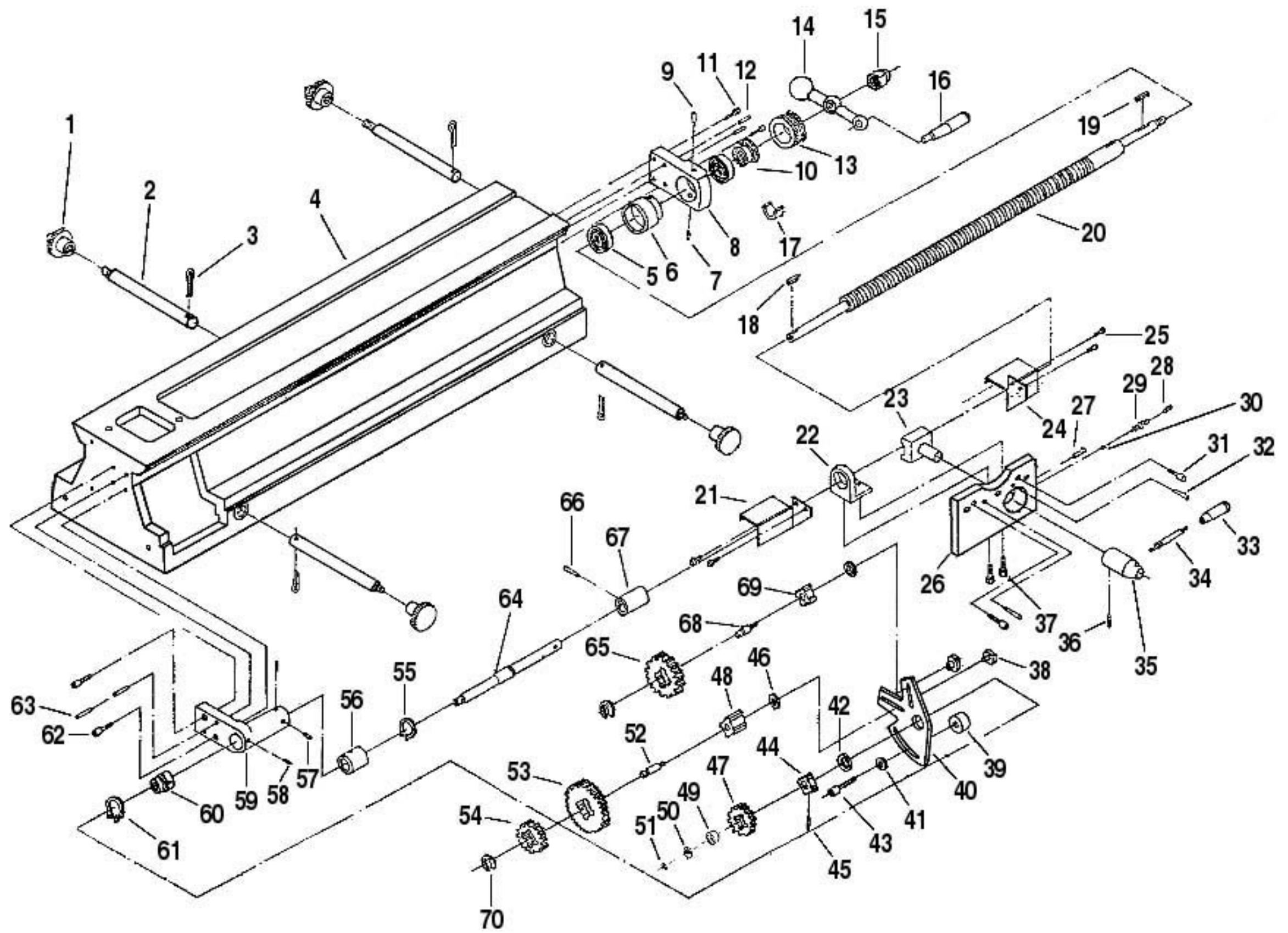

Bed and Gear / Powerfeed

Diagram Number	Part Number	Reference Number	Description
1	C30030		Cone Knob
2	C30063		Dead-Load Lever
3	S22540	3X26 GB91-86	Split Pin
4	C30061		Bed
5	S20090	8201 GB301-84	Plane Bearing
6	C30582		Bush Bearing
7	S11998	M6x6 GB71-85	Cone-Point Setscrew (S11932)
8	C30583		Trestle
9	C30050	6 GB1155-74	Oil Cup
10	C30584		Sleeve
11	S11971	M6x16 GB70-85	Hex-Head Screw
12	S22170	5x26 GB117-86	Taper Pin
13	C30585		Dial
14	C30070	12X50 GB4141.9-84	Ball-Crank Handle
15	S18160		Domed-Cap Nut (Acorn Nut)
16	C30070		Ball-Crank Handle
17	C30173		Spring Lamination

Diagram Number	Part Number	Reference Number	Description
18	S21260	5x20 GB1096-79	Plain Parallel Key
19	S21178	4x28 GB1096-79	Plain Parallel Key
20	C30586		Longitudinal-Feed Screw
21	C30587		Leadscrew Left Guard Shield
22	C30588		Feed-Screw Plate
23	C30589		Longitudinal Feed-Screw Nut
24	C30590		Leadscrew Right Guard Shield
25	S11655	M5x8 GB818-85	Cross Recessed Pan Head Screw
26	C30591		Longitudinal Nut Plate
27	S11973	M6x16 GB75-85	Full Dog-Point Setscrew
28	S11938	M6x8 GB73-85	Flat-Point Setscrew
29	C30590	0.8x4x15 GB2089-80	Spring
30	C30199	5 GB308-77	Steel Ball
31	S11971	M6x16 GB70-85	Hex-Head Screw
32	S22175	5X26 GB117-86	Taper Pin
33	C30054	M8x40 GB4141.14-84	Long-Handle Knob
34	C30053	M8x50 GB4141.15-84	Handle Lever

Bed and Gear / Powerfeed

Diagram Number	Part Number	Reference Number	Description
35	C30593		Handle Seats
36	S11654	M5X12 GB75-85	Full Dog-Point Setscrew
37	S11969	M6X16 GB5782-86	Hex-Head Bolts
38	C30082		T-Nut
39	C30462		Spacing Collar
40	C30594		Change-Gear Plate
41	S18140	8 GB97.1-85	Washer
42	S18170		Washer
43	S12331	M8x35 GB70-85	Hex-Head Screw
44	C30081S		Spline Housing (Hole should be drilled to fit the Shaft)
45	S22050	3x14 GB119-86	Straight Pin
46	C30215		Washer
47	C30159	60 Tooth	Change Gear
48	C30081		Spline Housing
49	C30206		Pressure Sleeve
50	C30216		Washer
51	S18095	M6 GB52	Nut

Diagram Number	Part Number	Reference Number	Description
52	C30080		Change-Gear Rod
53	C30143		Change Gear
54	C30159		Change Gear
55	S23200	15 GB894.1-86	External Snap Ring
56	C30595		Bush Bearing
57	C30050	6 GB1155-74	Oil Cup
58	S11642	M5X10 GB71-85	Cone-Point Set screw
59	C30596		Left Trestle
60	C30597		Shaft Sleeve
61	S23230	26 GB894.1-86	External Snap Ring
62	S11971	M6X16 GB70-85	Hex-Head Screw
63	S23230	5X26 GB117-86	Taper Pin
64	C30598		Shaft
65	C30143		Change Gear
66	S22180	4X3 GB117-86	Taper Pin
67	C30089		Sleeve Coupling

Bed and Gear / Powerfeed

Diagram Number	Part Number	Reference Number	Description
68	C30080		Change Gear (Shaft)
69	C30081		Spline Gear
70	S23080		External SnapRing 9

Gearbox Middle Pulley

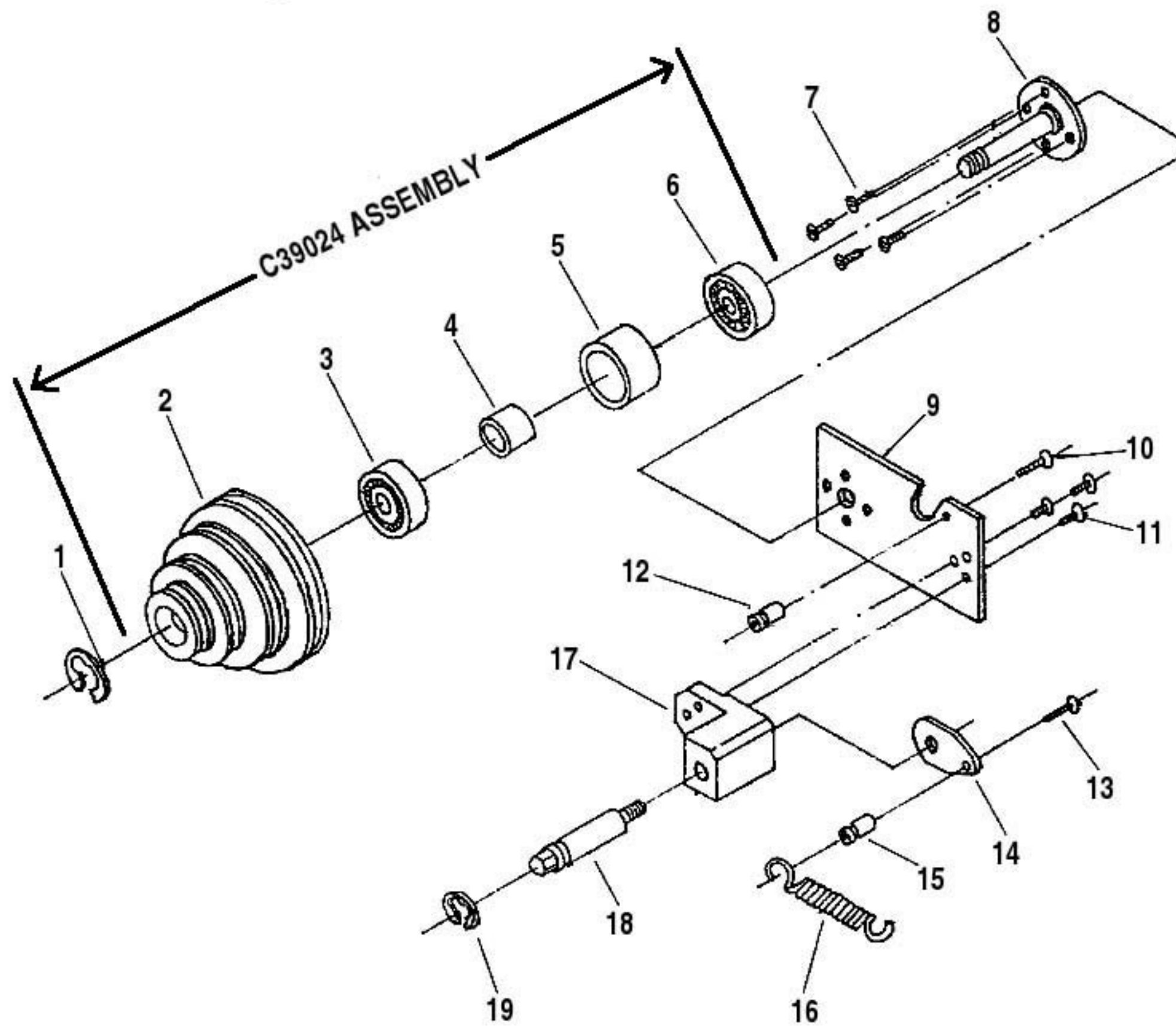

Gearbox Middle Pulley

Diagram Number	Part Number	Reference Number	Description
1	S23205	GB896-86	E-shaped Snap Ring
2	C30137		Middle Pulley
3	S20260	203 GB276-89	Deep-Groove Ball Bearings
4	C30198		Inner Spring Sleeve
5	C30197		Outer Spring Sleeve
6	S20260	60203 GB273-89	Dirt-Guard Deep-Groove Ball Bearings
7	S11603	M5 x 5 GB68-85	Slotted Countersunk-Head Screws
8	C30453		Pulley Shaft
9	C30455		Fascia
10	S11673	M4x15 GB68-85	Slotted Countersunk-Head Screws
11	S11953	M5x12 GB68-85	Slotted Countersunk-Head Screws
12	C30449		Sleeve
13	S11673	M4x15 GB68-85	Slotted Countersunk-Head Screws
14	C30450		Dead Plate
15	C30449		Sleeve
16	C30456	2x12x61.5 GB4142-84	Pullback Spring
17	C30452		Revolution-Axis Seat

Diagram Number	Part Number	Reference Number	Description
18	C30451		Revolution Axis
19	S23140	12 GB896-86	E-shaped Snap Ring
1-19	C39016		Assembly Tensioner, Idler Pulley (Assembly)
1-6	C39024		Idler Assembly Pulley

Gearbox Housing

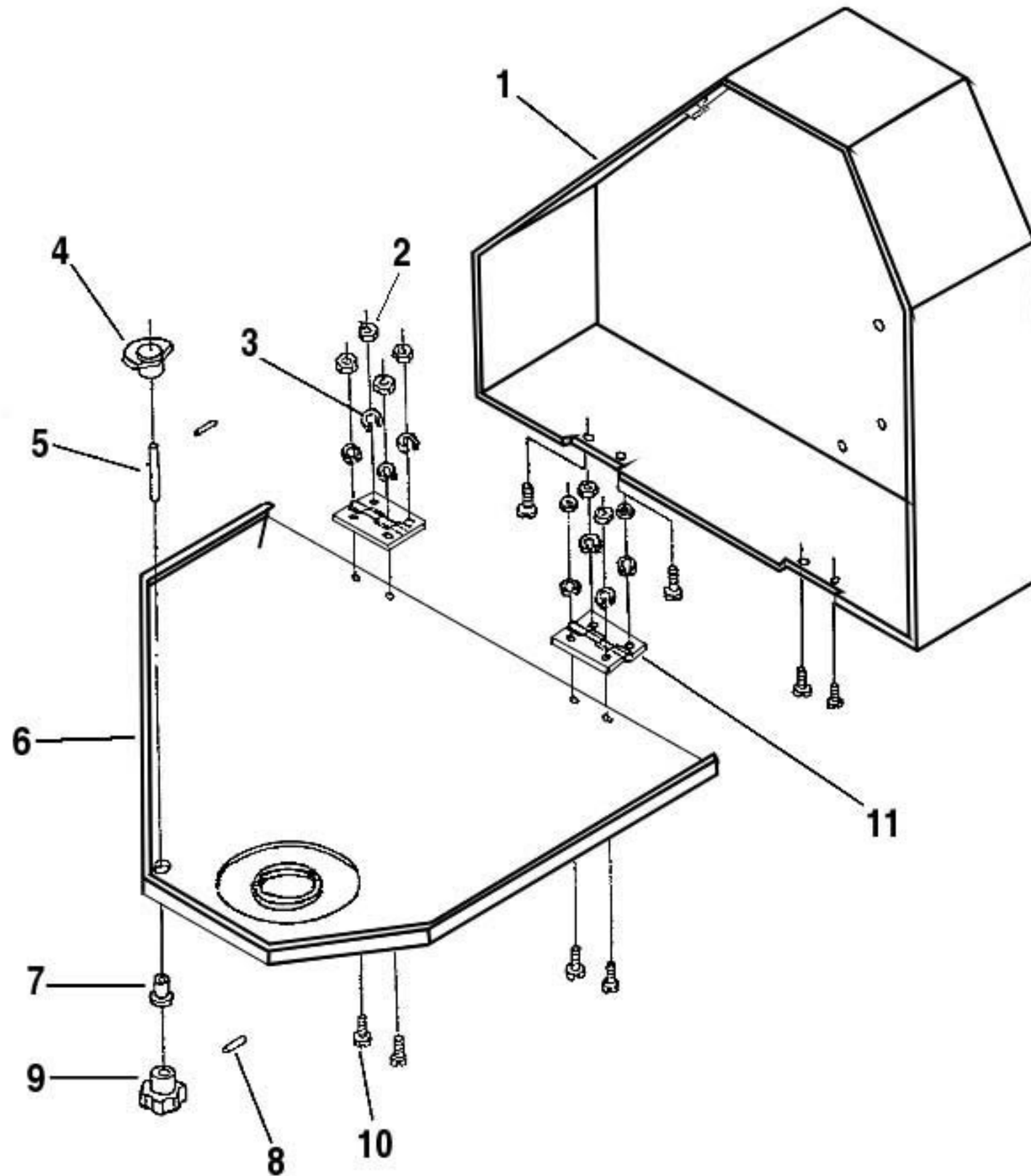

Gearbox Housing

Diagram Number	Part Number	Reference Number	Description
1	C30140		Compound Box
2	S18030	GB6170-85	Hexagon Nut
3	S18045	GB93-87	Spring Washer
4	C30093		Door Knob
5	C30042		Shaft
6	C30142		Compound Box Blind
7			Stationary Sleeve
8	S22140	GB117-86 3x18	Taper Pins
9	C39025	GB4141.29-84	Star-Grip Knob (8x32) (Assembly)
10	S11344	M4x10GB63-85	Slotted Cheese head Screws
11	C30141	50 GQ0478-89	Butt Hinge, 2"
	C39025		Door Locking Assembly
	C39011		Gearbox Cover Assembly
	C39024		Idler Pulley Assembly
	82-004		Switch

Carriage

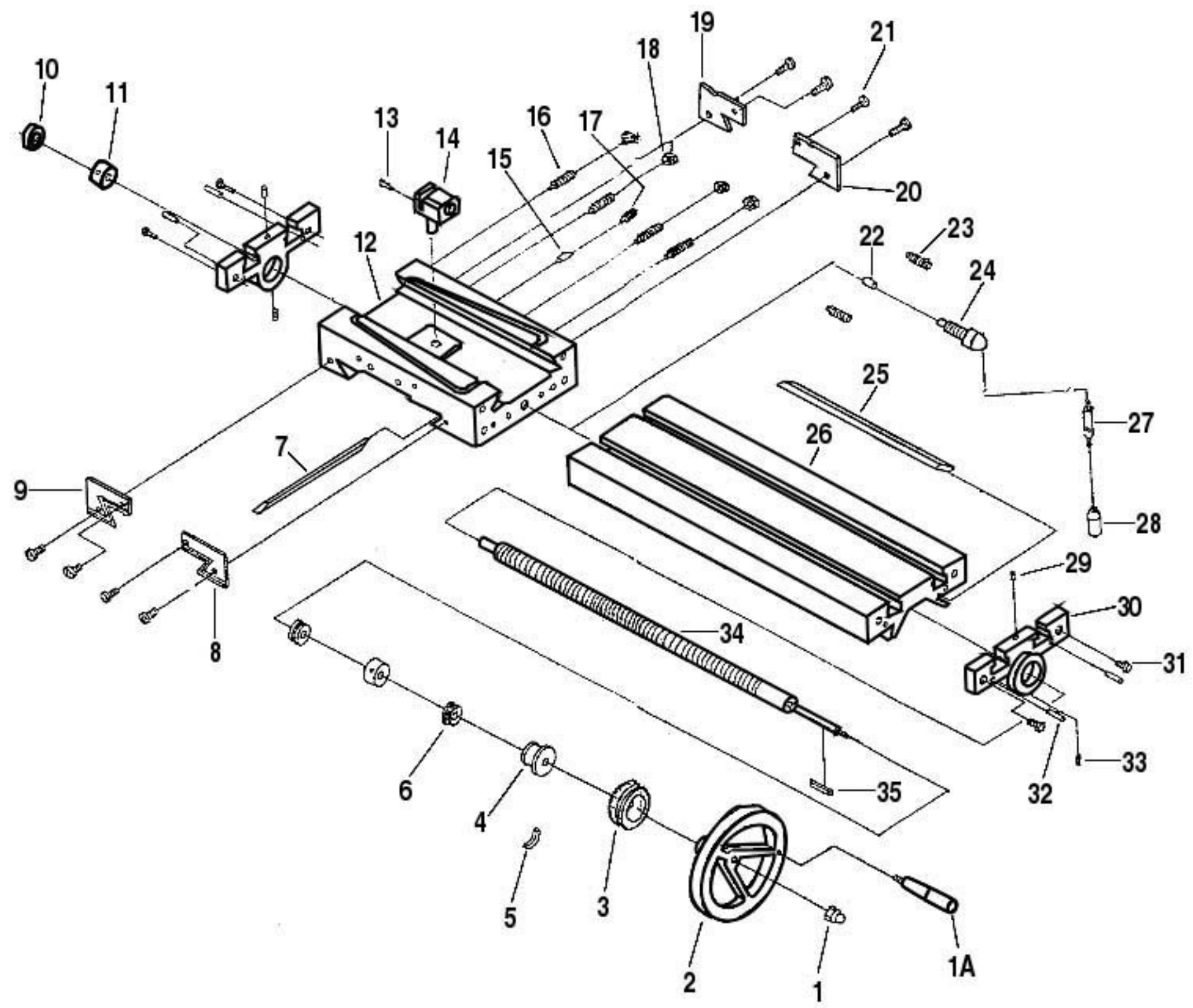

Bed and Carriage

Diagram Number	Part Number	Reference Number	Description
1	S18160	M10 GB923-88	Domed-Cap Nut
2	C30277	812x125 GB4141.2284	Handwheel
3	C30600		Dial
4	C30414		Dial Sleeve
5	C30173		Spring Lamination
6	S20090	8201 GB301-84	Rolling Bearing
7	C30066		Chock
8	C30443		Left Rear Scratchboard
9	C30444		Left Front Scratchboard
10	C30421		Spigot
11	C30073		Sleeve
12	C30602		Carriage
13	S11374	M4X16GB70-85	Hex-Head Capscrews
14	C30603		Cross Nut
15	S22420		Locking Pin
16	S12332	S12332 / M8x35 GB78-85	Dog-Point Hex Setscrew
17	S12568	M10x14GB79-85	Dog-Point Hex Setscrew

Diagram Number	Part Number	Reference Number	Description
18	S18125	M8 GB6172-85	Hex Nut
19	C30445		Right Front Scratchboard
20	C30446		Right Back Scratchboard
21	S11935	M5X8 GB818-85	Cross Recessed Pan Head Screws
22	S22420		Locking Pin
23	S12338	M8x35 GB79-85	Dog-Point Hex Setscrew
24	C30447		Locking Handle Seat
25	C30422		Chock
26	C30419		Bench
27	C30032	BM6X40 GB4141. 15-8	Knob Rod
28	C30033	BM6x26 GB4141. 14-84	Long-Sleeve Knobs
29	C30035	8 GB1155-79	Oil Cup
30	C30604		Cross-Feed Screw Seat
31	S12271	M8x16 GB70-85	Hex-Head Capscrews
32	S22175	5x26 GB117-86	Taper Pin
33	S11992	M6x12 GB71-85	Slotted Cone-Point Setscrew

Bed and Carriage

Diagram Number	Part Number	Reference Number	Description
34	C30605		Cross-Feed Screw Rod (Inch)
35	S21178	4x28 GB1096-85	Plain Parallel Key
36	C30278	M8X65 GB4141.5-84	Handle and Sleeve
	C30489		Cross-Feed Screw Rod (Metric)
	C30418		Nut Metric
	C30417		Screw Cross-feed Metric
1A	C30278	M8X65	Handle with Sleeve

Compound-Angle Toolpost

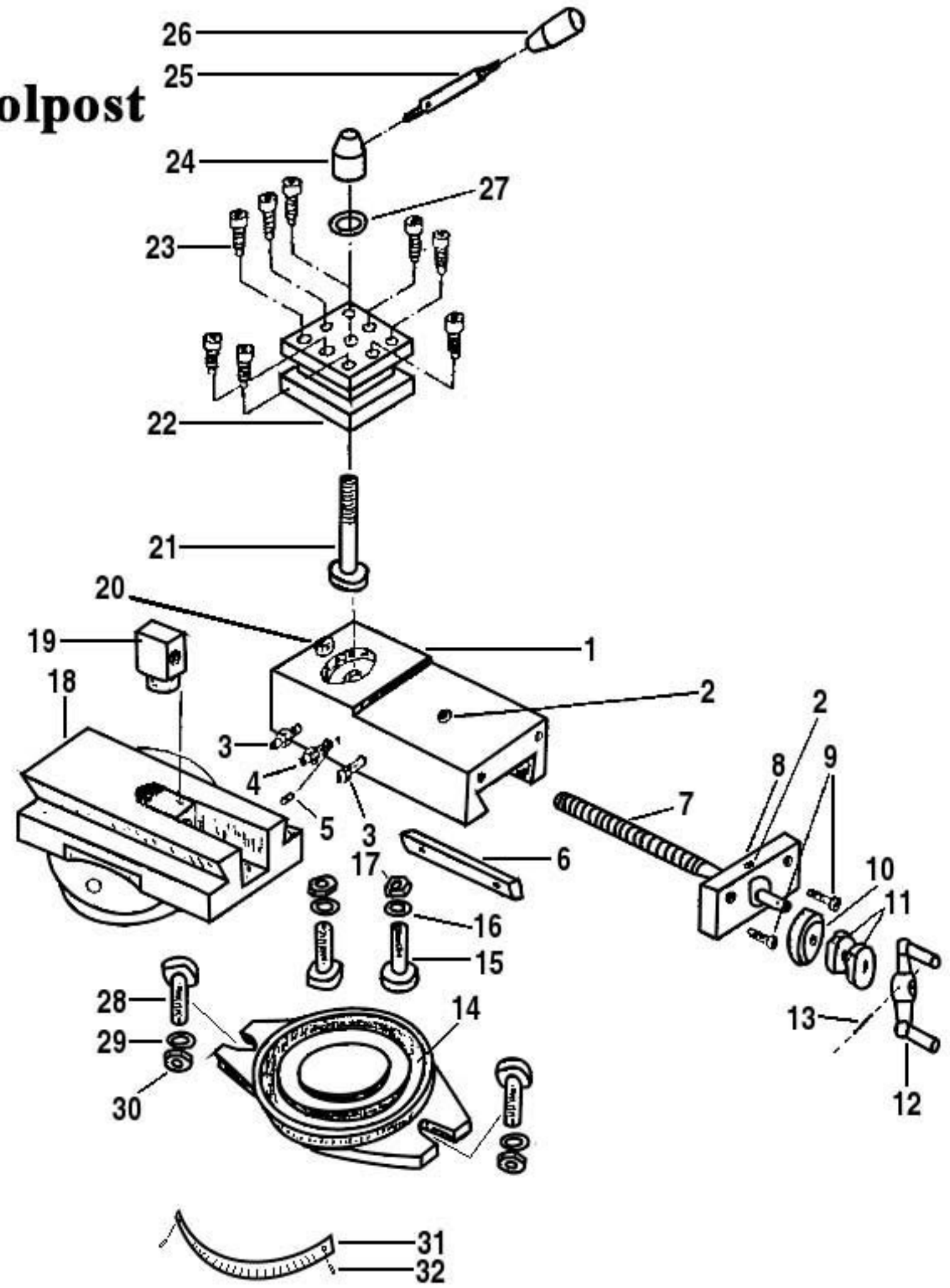

For Assistance: Please call toll free number 1-800-476-4849

Compound-Angle Toolpost

Diagram Number	Part Number	Reference Number	Description
1	C30175		Sliding Carriage
2	C30050		Oilcup
3	S11672	M5x16	Cone-Point Hexscrew with Nut
4	S11640	M5x10	Setscrew with Hex Nut
5	S22410		Locking Pin
6	C30176		Gib
7	C30611		Screw with Bearing
8	C30178		Hanger
9	S11971	M6x16	Hex-Socket Setscrew
10	C39027		Dial
11	C30220		Spanner Nut
12	C30179		Handle
13	S22110		Taper Pin
14	C30180		Revolving Bed
15	S12296	M8x20	Base Locking Bolt
16	S18140	M8	Washer

Diagram Number	Part Number	Reference Number	Description
17	S18125	M8x1.25	Hex Nut
18	C30181		Carriage Base
19	C30612		Carriage Nut
20	C30183		Ball with Spring
21	S12696	M10x65	Turret Bolt
22	C30184		Toolpost
23	S12311	M8x25	Hex Socket-Head Screw
24	C30185		Handle Seat
25	C30053		Toolpost Handle
26	C30054		Long Sleeve Knob
27	C30556	M10	Washer
28	S12626		Bolt (To attach to the cross-slide)
29	S18170	M10	Washer
30	S18155	M10	Nut
31	C30407		Scale CATP

Compound-Angle Toolpost

Diagram Number	Part Number	Reference Number	Description
32	S22355	M2.5X5	Rivet
	45-100		CATP Assembly

Steady Rest

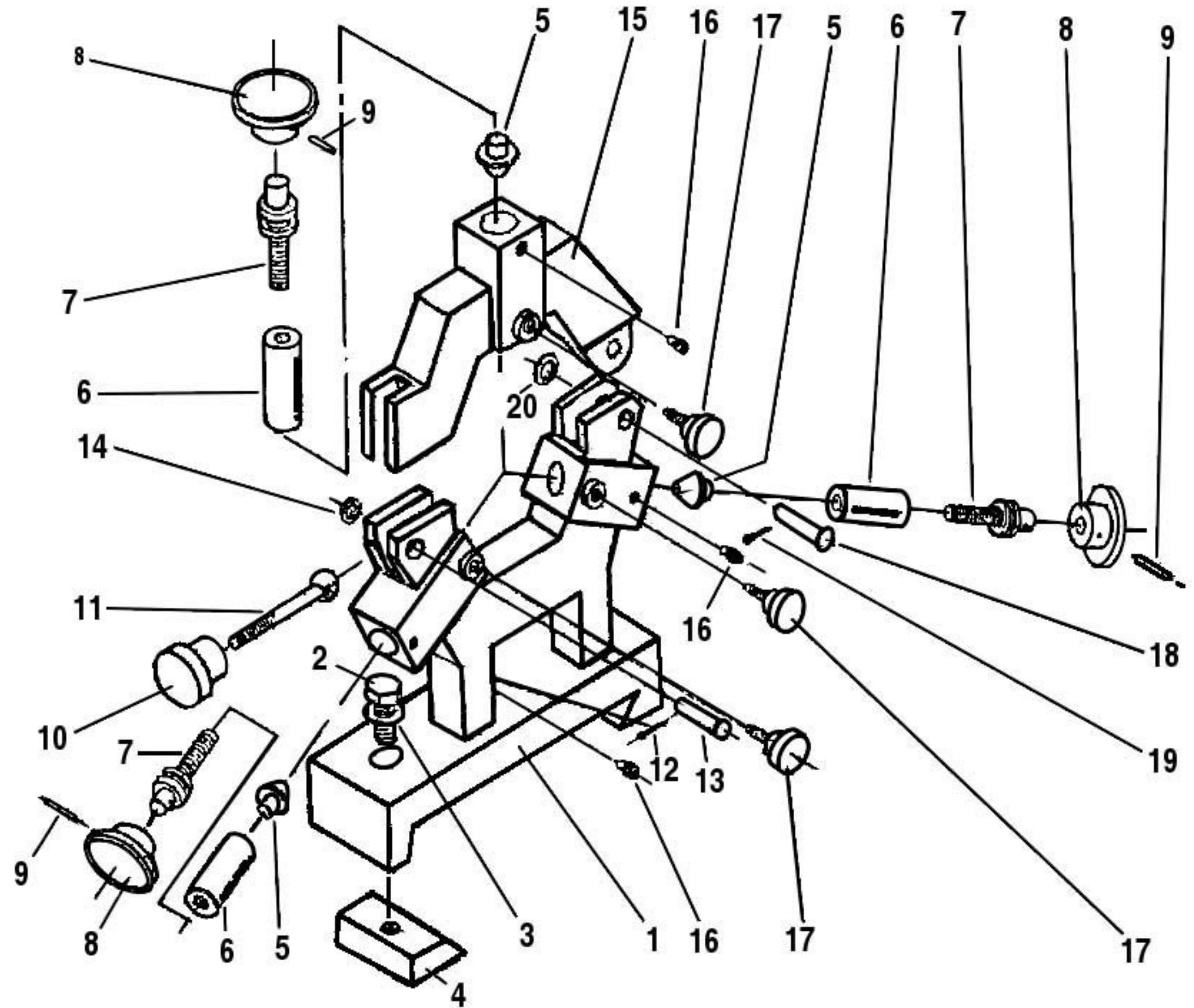

Steady Rest

Diagram Number	Part Number	Reference Number	Description
1	C30186		Center Frame
2	S12651	M10x45	Socket-Head Bolt
3	S18170	M10	Washer
4	C30187		Chock
5	C30188		Brass Head
6	C30189		Finger Sleeve
7	C30190		Adjusting Bolt
8	C30191		Knob
9	S22140		Taper Pin
10	C30192		Knob
11	C30193		Dog Bolt
12	S22510		Split Pin
13	S22620		Pivot Pin
14	S18110	M6	Washer
15	C30194		Center Frame Head
16	S11948	M6x10	Setscrew
17	C30195		Knurled Screw

Diagram Number	Part Number	Reference Number	Description
18	S22620		Pivot Pin
19	S22510		Split Pin
20	S18140		Washer
(5-9)	C39017		Brass Head and Sleeve Assembly

Follow Rest

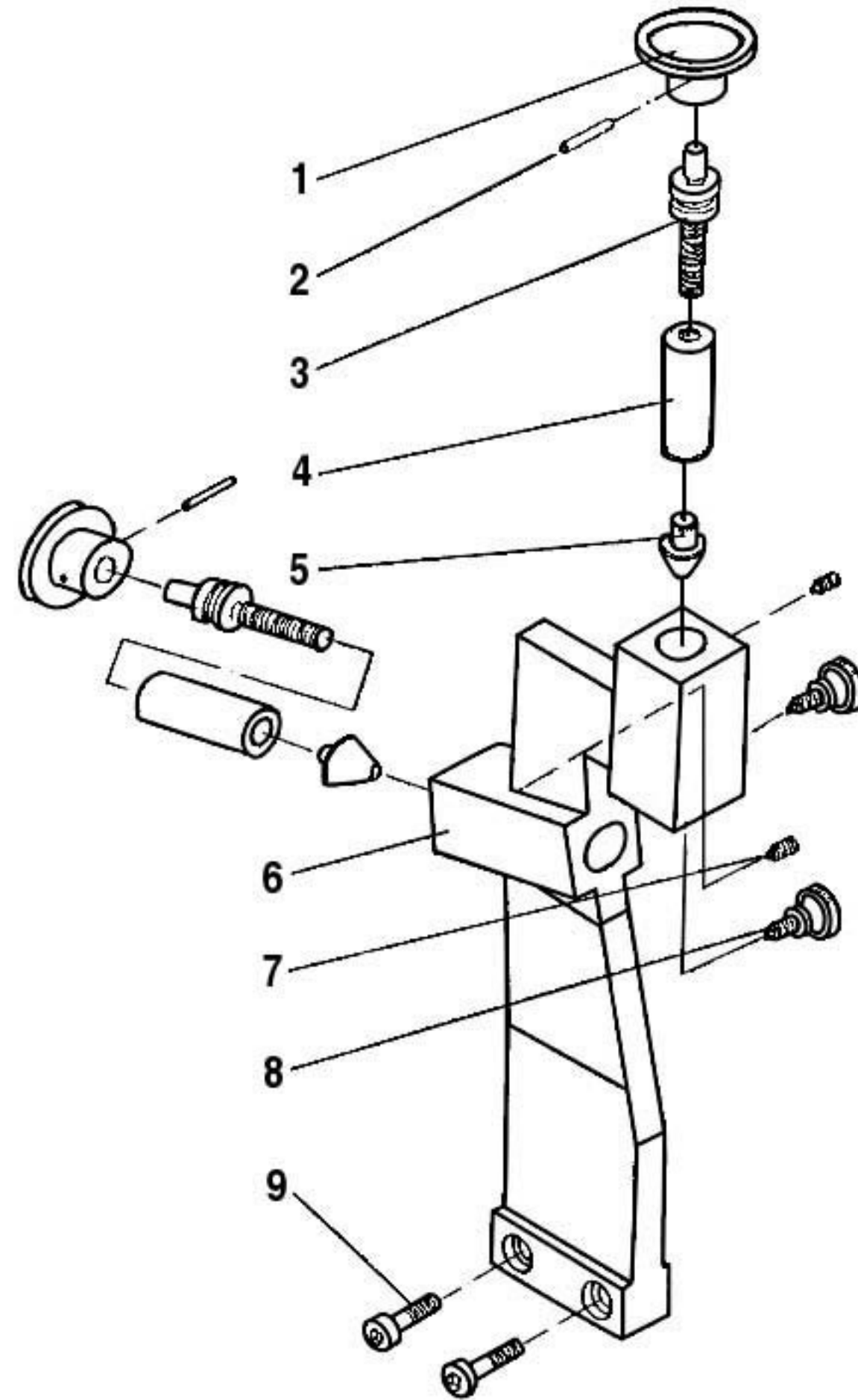

Follow Rest

Diagram Number	Part Number	Reference Number	Description
1	C30191		Knob
2	S22140		Taper Pin
3	C30190		Adjusting Bolt
4	C30189		Sleeve
5	C30188		Brass Head
6	C30196		Follow Rest Casting
7	S11948	M6x10	Setscrew
8	C30199	5	Knurled Screw (Steel Ball)
9	S12291	M8x20	Capscrew
(4-5)	C39017		Brass Head and Sleeve Assembly

Adjustable Tailstock

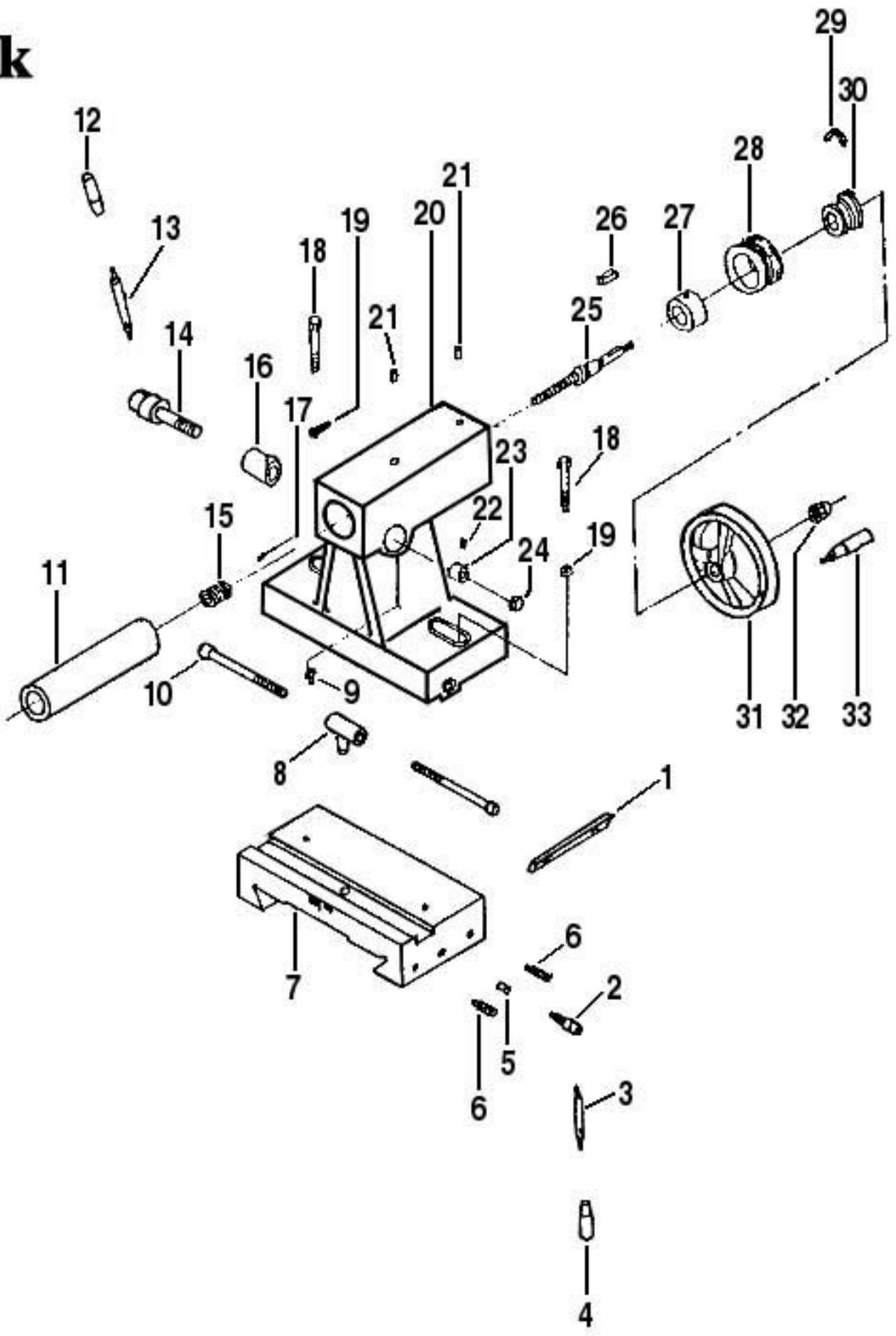

Adjustable Tailstock

Diagram Number	Part Number	Reference Number	Description
1	C30057		Gib
2	C30161		Locking Handle Seat
3	C30032		Handle Lever
4	C30033		Knob
5	S22420		Locking Pin
6	S12318	M8x2.5	Setscrew
7	C30162		Tailstock Carriage
8	C30163		Nut
9	S21211	(S21040)	T-Key
10	S12421	M8x80	Capscrew
11	C30164		Tailstock Sleeve
12	C30054		Knob
13	C30053		Handle Lever
14	C30052		Handle Seat
15	C30607	C30048 (Metric)	Tailstock Nut
16	C30051		Locking Sleeve
17	S11642	M5x10	Setscrew

Diagram Number	Part Number	Reference Number	Description
18	S12640	M10x40	Hex-Head Bolt
19	S18170	M10	Washer
20	C30168		Tailstock
21	C30050		Oil Nipple
22	S11952	M6x12	Setscrew
23	C30049		Locking Nut
24	C30170		Locking Base
25	C30608	C30056 (metric)	Screw
26	S21140		Key
27	C30171		Sleeve
28	C30600		Dial
29	C30173		Spring
30	C30174		Sleeve
31	C30059		Handwheel
32	S18160	M10	Acorn Nut
33	C30060		Handle

Adjustable Tailstock

Diagram Number	Part Number	Reference Number	Description
(1-33)	C39014	Adjustable	Tailstock Assembly
(28-30)	C39015		Floating Dial Assembly

Motor with Tensioner

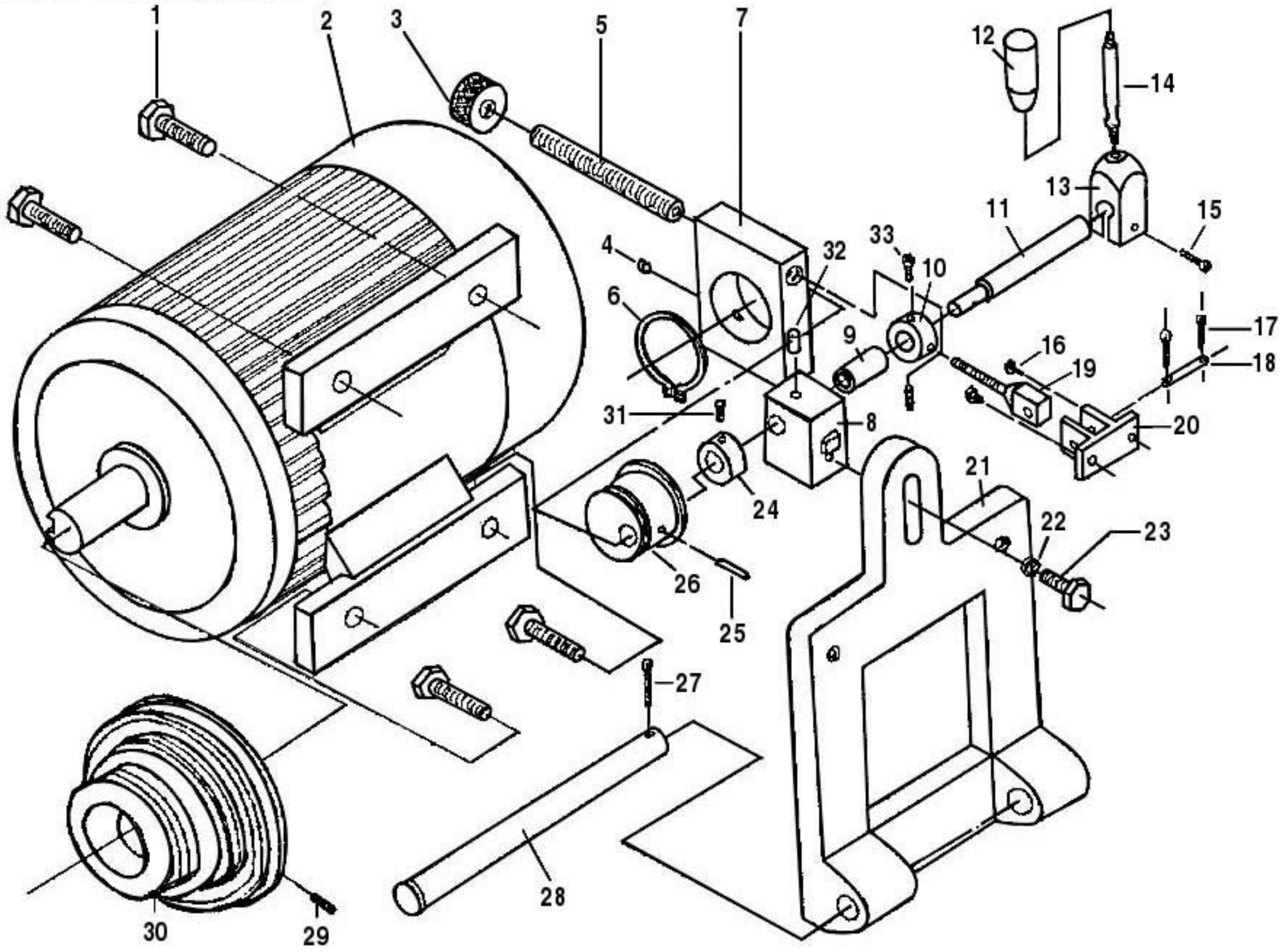

Motor with Tensioner

Diagram Number	Part Number	Reference Number	Description
1	S12290	M8x20 GB30	Hexagon-Head Bolt
2	C30475		110-V Motor, 0.55kw, 60 hz
	C30482		220-V Motor, 60 hz
3	C30396	M12	Screw Arbor with Knurled Knob
4	C30050	6 GB1155-79	Oilcup
5	C30448	M12	Screw Arbor with Knurled Knob
6	S23320	40 GB894.1-86	Shaft Circlips—Type A
7	C30398		Set
8	C30399		Locating Piece
9	C30400		Sleeve
10	C30401		Locating Piece
11	C30402		Shaft
12	C30054	M6x36GB4141.14	Knob
13	C30403		Handle Seat
14	C30053	M6x40GB4141.15	Handle Lever
15	S11991	M6x20 GB70-85	Capscrew
16	S11670	M5x15 GB5-76	Hexagon-Head Bolt

Diagram Number	Part Number	Reference Number	Description
17	S22520	2x12 GB91-86	Split Pin
18	C30404	6x28 GB119-86	Pivot Pin
19	C30405		Attachment Screw Arbor
20	C30406		Motor Tension Plate
21	C30476		Motor Mount
22	S18135	8 GB93-87	Lockwasher
23	S12290	M8x20 GB5781	Hexagon-Head Bolt
24	C30401		Locating Sleeve
25	S22152	4x24 GB117-86	Taper Pin
26	C30411		Eccentric Wheel
27	S22530	3x16	Cotter Pin
28	C30484		Straight Pin
29	S12248	M8x10 GB73	Flat-Point Screw
30	C30474		Motor Pulley
31	S11608	M5x5	Setscrew
32	C30050	6 GB1155-79	Oilcup
33	S11641	M5x10	Capscrew

Motor with Tensioner

Diagram Number	Part Number	Reference Number	Description
	S25100		Run Capacitor
	S25101		Start Capacitor
	C39015		Motor Tensioner Assembly