

# 14 Diagrams & Parts List

## Lathe Bed

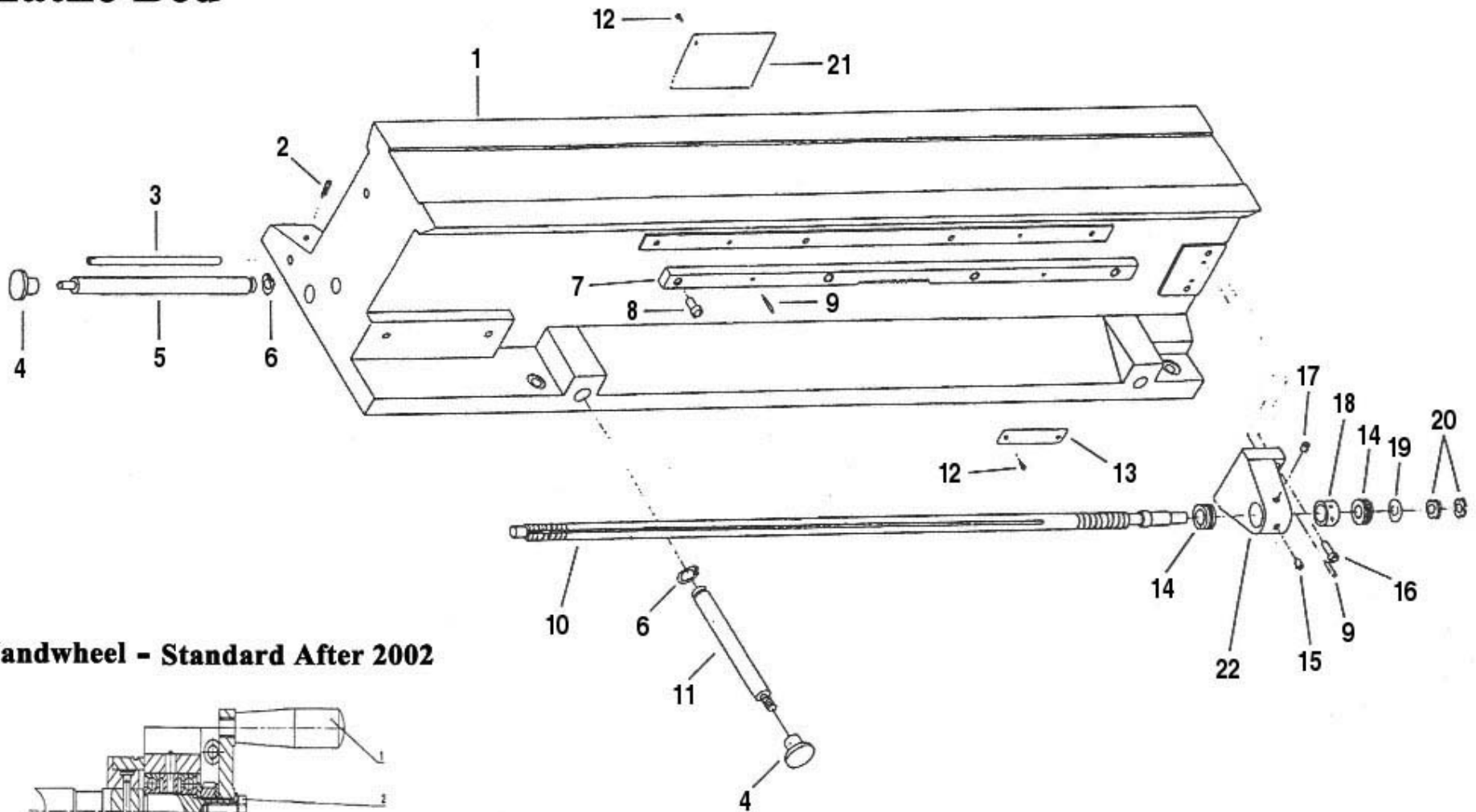

## Handwheel - Standard After 2002

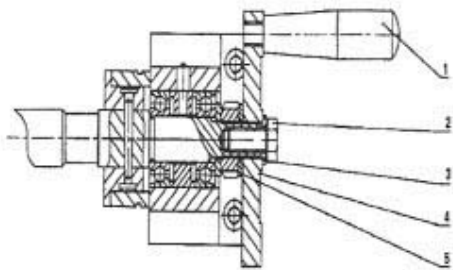

# Lathe Bed & Handwheel

Diagram Number	Part Number	Reference Number	Description
1	G01001 G01001L	1-01	Bed for GN-1324 Bed for GN-1340
2	G01002	S11992	Cone-point set screw M6 x 20
3	G01003	1-02	Shaft Pin
4	G01004	C30030	Lifting Knob
5	G01005	1-22	Lifting Pin (II)
6	G01006	GB894.1	Snap Ring M20
7	G01007	Rack for	GN-1324
	G01007L	1-12	Rack for GN-1340 ( Note: This is two pieces)
8	G01008	S11340	Sockethead Cap Screw M6 x20
9	G01009	GB117	Taper Pin M4 x 22
10	G01010		Leadscrew for GN-1324
	G01010L	1-13	Leadscrew for GN-1340
11	G01011	C30063	Lifting Pin
12	G01012	BG827	Rivet M2 x 5
13	G01013	1-24	Smithy Plate
14	G01014	GB292	Angular Contract Bearing 46102
15	G01015	GB71	Setscrew M6 x 10
16	G01016	GB70	Hex-Socket Screw M6 x 20
17	G01017	C30050	Oiler #6

Diagram Number	Part Number	Reference Number	Description
18	G01018	1-15	Spacer
19	G01019	GB97.1	Washer M12
20	G01020	GB812	Spanner Nut M12 X 1.25
21	G01021	1-25	Data Plate
22	G01022	1-14	Leadscrew Support

## Additional Leadscrew Dial Assembly G91023

1	G01023		Leadscrew Outer Dial
2	G05068		Leadscrew Inner Dial
3	G05069		Dial Spring
4	S11946		Dial Setscrew
5	G91023		Leadscrew Assembly

## Handwheel Assembly

1	G01028	HY8310.4-1	Handle
2	SS160		Bolt, 5/16"-18 x 1/2"
3	S18140	GB97.1-85	Washer, M8
4	G01027	G1324.1-29	Hand Wheel
5	S18200	GB97.1-85	Washer, M12

## Motor and Mount

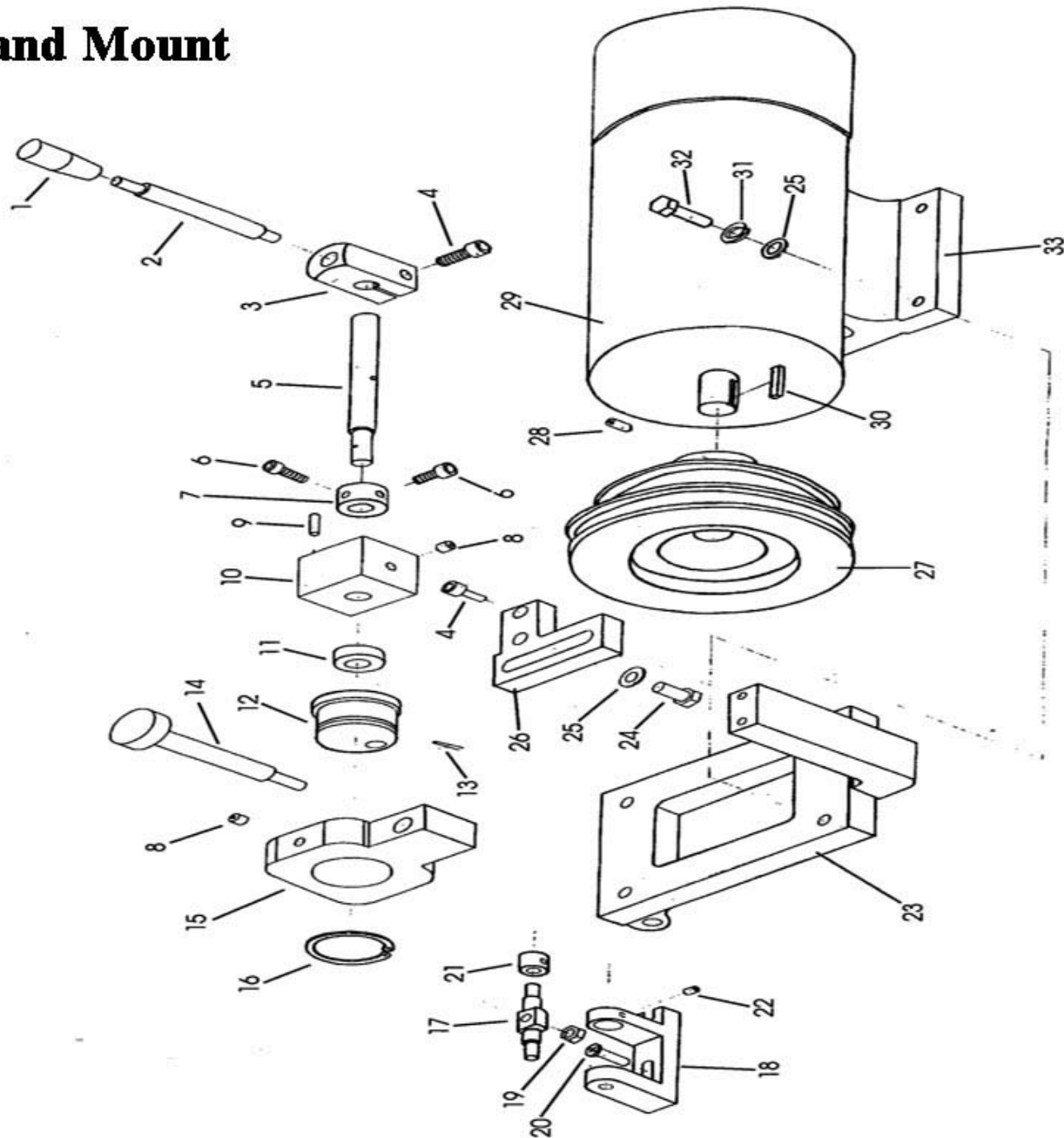

# Motor & Mount

Diagram Number	Part Number	Reference Number	Description
1	G02001	JB/T7271.5	Handle sleeve BM 8 x 40
2	G02002	JB/T271.6	Handle BM 8 x 80
3	G02003	1-11	Handle Seat
4	G02004	S11971	Sockethead capscrew M6 x 16
5	G02005	1-10	Cam Shaft
6	G02006	S11671	Sockethead capscrew M5 x 16
7	G02007	1-09	Bushing (II)
8	G02008	C30050	Oiler #6
9	G02009	GB119	Pin 4 x 18
10	G02010	1-08	Block, Tensioner, center
11	G02011	1-07	Bushing (1)
12	G02012	1-05	Cam
13	G02013	GB117	Taper Pin 3 x 16
14	G02014	1-19	Adjusting Knob
15	G02015	1-06	Cam Seat
16	G02016	GB6170	Snap Ring 40
17	G02017	1-20	Shaft Pin

Diagram Number	Part Number	Reference Number	Description
18	G02018	1-17	Standoff Bracket
19	G02019	GB6170	Hex Nut M6
20	G02020	S11340	Sockethead Capscrew M6 x 20
21	G02021	1-18	Bushing
22	G02022	S1132	Conepoint Setscrew M4 x 6
23	G02023	1-03	Motor Mount
24	G02024	S12290	Hex Bolt M8 x 28
25	G02025	S18140	Washer M8
26	G02026	1-16	Mount end bracket
27	G02027	(G02027A ) 1-04	Motor Pulley
28	G02028	(S11958) GB71	Setscrew M6 x 10
29	G02029	SS777	Motor
30	G02030	S18140	Washer M8
31	G02031	Key	
32	G02032	S12290	Hex Bolt M8 x 20
33	G02033		Motor Bracket

New DC	Motor
	G02029-110
	G02029-220

Granite Motor	Upgrade
	GMX02029-110
	GMX02029-220

# Headstock

## Clutch Mechanism

March 2000-Present Models

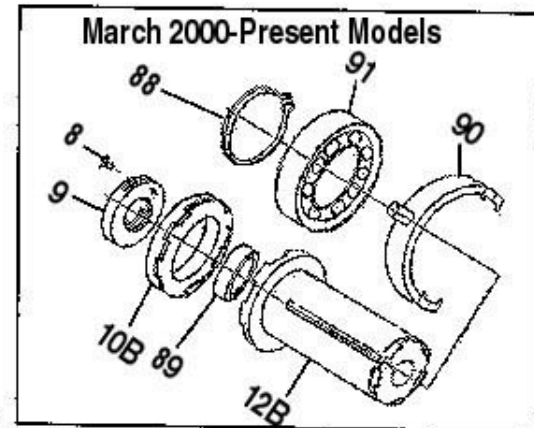

Note:  
Chuck guard - 15-610

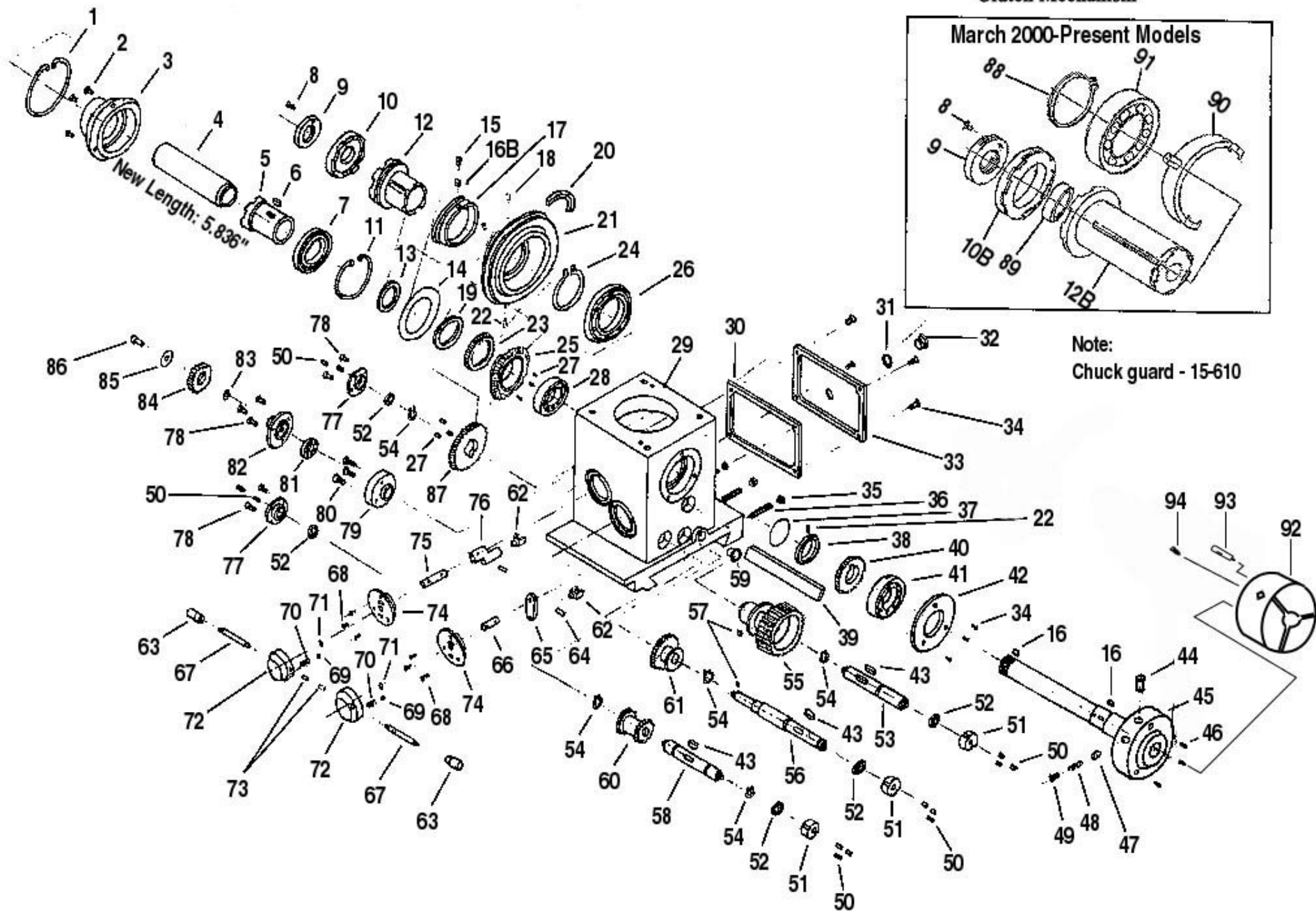



# Headstock

Diagram Number	Part Number	Reference Number	Description
1	G03001	GB893 1-86	Snap ring M100
2	G03002	GB819-85	Countersunk Phillips M6x20
3	G03003	2-28	Pulley seat
4	G03004	2-10	Sleeve
5	G03005	2-25	Right Coupler
6	G03006	GB1096-79	Key 3x20
7	G03007	GB276-82	Ball bearing
8	G03008	GB68-85	Countersunk Phillips M5x8
9	G03009	CQ9108.206	Lock nut M34x1.5
10	G03010	CQ9108.212	Left Coupler
11	G03011	GB893.1-86	Snap ring A80
12	G03012	2-13	Center coupler
13	G03013	2-11	Spanner
14	G03014	2-08	Oil collar -Slinger
15	G03015	(S11342) GB65-85	Setscrew M4x10
16	G03016	(S21512) GB1096-79	Key 5x12
17	G03017	(G08017)2-09	Coupler sleeve 16B 6X14 (S21530)

Diagram Number	Part Number	Reference Number	Description
18	G03018	GB1096-79	Key 6x14
19	G03019	2-27	Spacer
20	G03020	GB1171-74	V-belt A1000
21	G03021	2-07	Pulley
22	G03022	GB71-85	Setscrew M6x8
23	G03023	2-26	Gear (ii)
24	G03024	GB8894.186	Snap ring A65
25	G03025	2-24	Bevel gear
26	G03026	GB276-82	Ball bearing 113
27	G03027	GB73-85	Setscrew M5x10
28	G03028	GB297-84	Taper roller bearing E2001710E
29	G03029	2-01	Headstock
30	G03030	2-16	Gasket
31	G03031	GB1235-76	O-ring 25x24
32	G03032	Q/ZB20	Oil plug M20x1.5
33	G03033	1-17	Gearbox cover
34	G03044	GB68-85	Flathead Phillips M5x20

# HeadStock

Diagram Number	Part Number	Reference Number	Description
35	G03035	GB6172-86	Flathead Phillips M5x20
36	G03035	GB6172-86	Hex nut M10
37	G03036		Wire 1.2x190
38	G03038	2-52	Spacer
39	G03039	2-20	Gib
40	G03040	2-23	Gear
41	G03041	GB297-84	Taper rolling bearing E2007108E
42	G03042	2-22	Bearing cover
43	G03043	GB1096-79	Key 5x20 (use 30mm key)
44	G03044	2-45	Cam
45	G03045	2-21	Spindle
46	G03046		Three-jaw chuck
47	G03047	2-43	Stopper
48	G03048	2-44	Spring
49	G03049	GB67-85	Setscrew M8x20
50	G03050	GB73-85	Setscrew M5x6
51	G03051	2-29	Bearing cover
52	G03052	GB276-82	Ball bearing 18

Diagram Number	Part Number	Reference Number	Description
53	G03053	2-30	Shaft #1
54	G03054	GB894.1-86	Snap ring 16
55	G03055	2-31	Gear
56	G03056	2-34	Shaft #3 (Has 30mm T-slot)
57	G03057	GB1096-79	Key 5x6
58	G03058	2-32	Shaft #2
59	G03059	GB1160-79	Oil glass
60	G03060	2-33	Duplex gear
61	G03061	2-35	Sliding gear
62	G03062	CQ9101.6-52A	Fork
63	G03063	C30054	Handle Sleeve M8x40
64	G03064	G117-86	Taper pin 3x20
65	G03065	2-47	Arm
66	G03066	2-48	Crank shaft (III)
67	G03067	GB4141.15-84	Handle M8x50
68	G03068	GB819-85	Setcrew M5x10

# HeadStock

Diagram Number	Part Number	Reference Number	Description
69	G03069	(C30126) GB308-77	Ball 6.5
70	G03070	GB2089-80	Spring 0.8x5x25
71	G03071	GB1235-76	Handle seat 12x50
72	G03072	GB4141.1984	Handle seat 12x50
73	G03073	GB117-86	Taper pin 5x50
74	G03074	2-46	Cover
75	G03075	2-42	Crank shaft (II)
76	G03076	2-41	Crank (II)
77	G03077	2-05	Bearing cover
78	G03078	GB68-85	Setscrew M5x12
79	G03079	2-04	Bearing seat
80	G03080		Hex socket setscrew (M5x25)
81	G03081	GB276-82	Ball bearing 103
82	G03082	2-02	Bearing cover
83	G03083	GB1235-76	O-ring 22 x 2.4
84	G03084	2-03	Drive gear
85	G03085	CJ0625.2-18	Washer M6

Diagram Number	Part Number	Reference Number	Description
86	G03086	GB5783-86	Hex bolt M6x12
87	G03087	2-06	Gear
88	S23055		Snap ring M55
89	G03089	2-55	Spacer
90	G03090	2-37-00	Arm
91	G03091	GB276-84	Bearing, 55 x 90 x18
92	G03046		3 Jaw Chuck
93	G03088		Chuck Stud Camlock
94	S11951		Stud Screw

## Clutch Mechanism-2000 to Current

8	G03008	GB68-85	Countersunk Phillips M5x8
9	G03009	CQ9108.206	Lock nut M34x1.5
10B	G03010B	G1324.212B	Coupler Left
12B	G03012B	G1324.213B	Coupler Center
88	S23065		Snap ring M55
89	G03089	2-55	Spacer
90	G03090	2-37-00	Arm
91	G03091	GB276-84	Bearing, 55 x 90 x18





**Smithy.**

## Pulley Box for Models After to May 2003

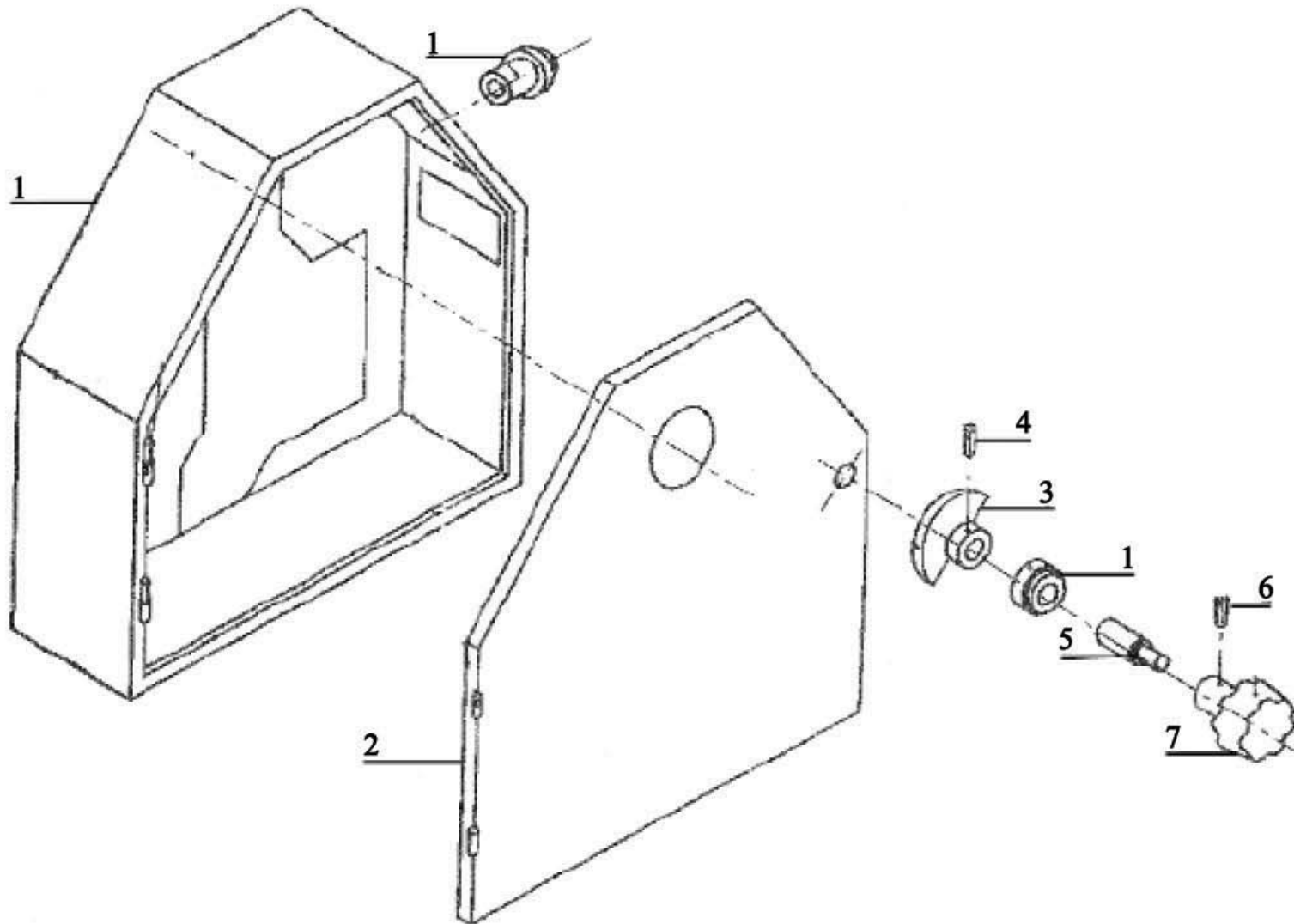

Or Visit [www.Smithy.com](http://www.Smithy.com)

# Pulley Box for Models Prior to May 2003

Diagram Number	Part Number	Reference Number	Description
1	G04001	2-18	Door
2	G04002	2-49	Pulley box
3	G04003	2-37	Slide
4	G04004	2-36	Lever arm (I)
5	G04005	GB894.1	Snap ring M8
6	G04006	S11952	Cone point setscrew M6x12
7	G04007	2-38	Spacer
8	G04008	2-40	Lever shaft (I)
9	G04009	GB117 (S22091)	Taper pin 4x26
10	G04010	2-39	Lever arm
11	G04011	CQ1909.7-18	Pin
12	G04012	CQ9109.7-19	Knob
13	G04013	GB117 (S22218)	Taper pin 2x18
14	G04014	CQ9109.7-17	Spring
15	G04015	S11912	Conopoint setscrew M6x8
16	G04016	CQ9109.716	Locating pin
17	G04017	GB117	Taper pin 3x20

Diagram Number	Part Number	Reference Number	Description
18	G04018	GB4141.29	Knob 8x32
19	G04019		Knob
20	G04020		Setscrew
21	G04021		Hex nut
22	G04022	GB827	Rivet 2x5
23	G04023	8/1-04	Speed dial
24	G04024		Lock washer
25	G04025		Potentiometer
26	G04026		Switch
27	G04027	GB818	Panhead Phillips screw M5x16
28	G04028	GB818	Panhead Phillips screw M5x12
29	G04029	8/1-01	Electrical box
30	G04030	SS702 (Use SS770)	SCR module
31	G04031	GB818	Panhead screw M4x12
32	G04032	GB97.1	Washer M4
33	G04033	GB93	Lock washer M4
34	G04034	GB6170	Hex nut M4

### Pulley Box Model Prior to May 2003

Diagram Number	Part Number	Reference Number	Description
35	G04035	GB6170	Hex nut M5
36	G04036	GB93	Washer M5
37	G04037	GB97.1	Lock washer 5
38	G03038	8/1-03	Wire cover
39	G03039	GB894.1	Snap ring 10
40	G03040	2-51	Latch
41	G03041		Mill/lathe plate
42	G04042		Taper Pin M5x25
	G94001		Door and Pulley Box Assembly
	G04047		Fuse

### Pulley Box for Models After to May 2003

Diagram Number	Part Number	Reference Number	Description
1	G04002N	G1324.2-49Z-2	Pulley Box-Includes Hinge and Bushing welded to pulley box
2	G04001N	G1324-0.49Z-1	Pulleym Box Door includes hinges and bushing welded to door
3	G04043	CQ6132W.4.1-10	Locking Piece
4			Taper Pin
5	G04040N	CJ0625.130	Shaft
6	G04042	S22170	Taper Pin 5 x 25
7	G04018N	JB/T7274.494	Knob 10 x 40



# Mill / Drill Head

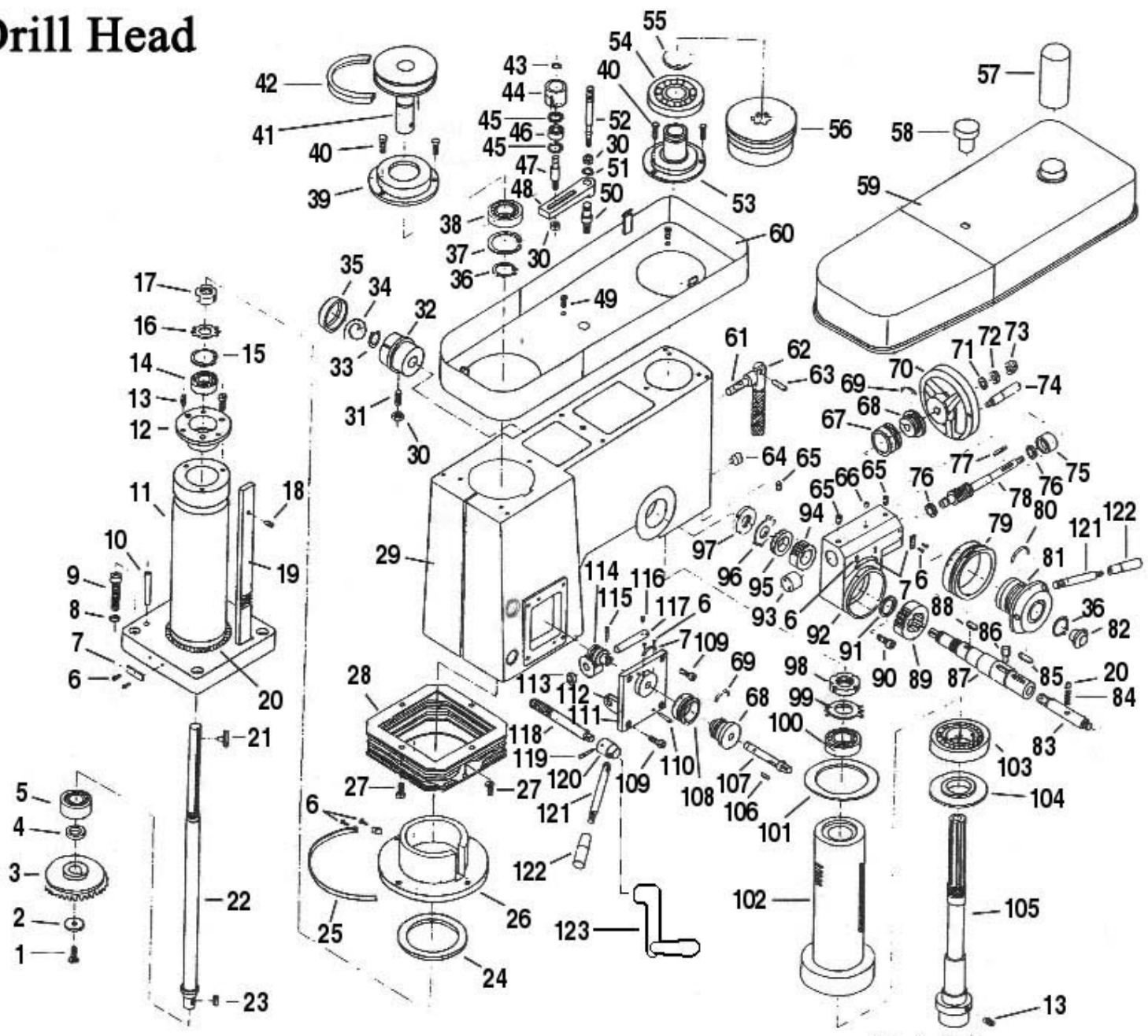

# Mill / Drill Head

Diagram Number	Part Number	Reference Number	Description
1	G05001	GB68	Setscrew M5x10
2	G05002	3-30	Washer
3	G05003	3-29	Bevel gear
4	G05004	3-28	Spacer
5	G05005	GB276	Ball bearing E205Z
6	G05006	GB827	Rivet 2x5
7	G05007	Z04124-63	Indicator
8	G05008	S18195	Lock washer M12
9	G05009	GB70	Hex-socket setscrew M12x1.75x30mm
10	G05010	GB118	Taper pin 8x30
11	G05011	3-27	Column
12	G05012	3-41	Bearing seat
13	G05013	GB75	Setscrew M6x12
14	G05014	GB292	Ball bearing E46204Z
15	G05015	GB893	Snap ring
16	G05016	GB858	Lock washer
17	G05017	GB812	Spanner nut M20x1.5

Diagram Number	Part Number	Reference Number	Description
18	G05018	GB65	Setscrew M5x16
19	G05019	3-38	Rack
20	G05020	GB308	Ball
21	G05021	3-05	T-key
22	G05022	3-06	Mill shaft
23	G05023	GB1096	Key 6x12
24	G05024	3-26	Spacer
25	G05025	3-25	Angle plate
26	G05026	3-24	Cover mount
27	G05027	GB67	Panhead slotted screw M5x8
28	G05028	3-23	Column cover
29	G05029	3-40	Mill/drill head
30	G05030	GB6172	Jam nut M8
31	G05031	GB71	Setscrew M8x25
32	G05032	Z7030.2-20	Spring housing
33	G05033	GB894	Snap ring M20
34	G05034	CQ9106-53	Coil spring

# Mill / Drill Head

Diagram Number	Part Number	Reference Number	Description
35	G05035	ZQ4124-59	Spring cover
36	G05036	GB894	Snap ring M30
37	G05037	GB893	Snap ring M62
38	G05038	GB276	Ball bearing
39	G05039	3-03	Bearing seat #1
40	G05040	GB5783	Hex bolt M5x16
41	G05041	3-04	Mill pulley
42	G05042	GB1171	V-belt A900
43	G05043	GB894	Snap ring M10
44	G05044	3-14	Sleeve
45	G05045	GB893	Snap ring M26
46	G05046	GB276	Ball bearing
47	G05047	3-15	Roller shaft
48	G05048	3-16	Tensioner
49	G05049	GB67	Panhead slotted setscrew M6x8
50	G05050	3-07	Fulcrum
51	G05051	GB894	Snap ring M15
52	G05052	3-08	Cover lock bolt

Diagram Number	Part Number	Reference Number	Description
53	G05053	3-13	Bearing seat #2
54	G05054	GB276	Ball bearing E208
55	G05055	GB894	Snap ring M40
56	G05056	3-12	Spindle pulley
57	G05057	3-11	Mill cap
58	G05058	C30030	Knob
59	G05059	3-02	Upper cover
60	G05060	3-01	Lower cover
61	G05061	ZQ4124-38	Locking bolt
62	G05062	ZQ4124-39	Locking handle
63	G05063	GB119	Pin4x18
64	G05064	Z7030.2-14	Eccentric shaft
65	G05065	S11942	Conepoint slotted setscrew M6x10
66	G05066	C30050	Oiler #6
67	G05067	3-46	Dial
68	G05068	CJ0625.328	Dial



# Mill / Drill Head

Diagram Number	Part Number	Reference Number	Description
69	G05069	Use C30173	Spring piece
70	G05070	GB414.22	Handwheel B12x100
71	G05071	GB97	Washer M10
72	G05072	GB6172	Jam M10
73	G05073	S18160	Acorn nut M10
74	G05074	GB4141.5	Handle M6x50
75	G05075	3-45	Bushing #2
76	G05076	GB276	Ball bearing 1000801
77	G05077	GB1096	Key 4x25
78	G05078	3-43	Worm-gear shaft
79	G05079	3-20	Dial
80	G05080	CQA9111.808	Spring piece
81	G05081	3-19	Handle seat
82	G05082	JB1357	Knob
83	G05083	3-18	Locking shaft
84	G05084	CQ9106-31	Spring
85	G05085	S21805	Key 8x25
86	G05086	CQA9111.8-06	Locking piece

Diagram Number	Part Number	Reference Number	Description
87	G05087	3-22	Feeding shaft
88	G05088	GB1096	Key 8x14
89	G05089	3-21	Worm gear
90	G05090	S11971	Sockethead capscrew M6x16
91	G05091	CQA9111.8-2	Washer
92	G05092	3-44	Worm-gear box
93	G05093	3-42	Bushing #1
94	G05094	3-34	Main gear
95	G05095	3-33	Gear
96	G05096	GB858	Lock washer M22
97	G05097	GB812	Spanner nut M22x1.5
98	G05098	GB812	Spanner nut M30x1.5
99	G05099	GB858	Lock washer M30
100	G05100	GB292	Ball bearing E46206101
101	G05101	Z7030.2-15	Rubber mat
102	G05102	3-09	Quill



# Mill / Drill Head

Diagram Number	Part Number	Reference Number	Description
103	G05103	GB292	Ball bearing E46208
104	G05104	3-48	Cover
105	G05105	3-10	Mill/drill spindle
106	G05106	GB1096	Key 4x10
107	G05107	3-35	Shaft
108	G05108	3-36	Dial
109	G05109	S11671	Sockethead capscrew M5x16
110	G05110	S22140	Taper pin 3x20
111	G05111	3-37	Mount plate
112	G05112	ZQ4124.54	Worm gear
113	G05113	CQA9111.705	Spacer
114	G05114	3-39	Worm gear
115	G05115	GB117	Taper pin 3x20
116	G05116	GB71	Setscrew M4x8
117	G05117	CQZ9111.706	Shaft
118	G05118	3-32	Locking bolt
119	G05119	GB117	Taper pin 4x26
120	G05120	3-31	Locking handle seat

Diagram Number	Part Number	Reference Number	Description
121	G05121	GB4141.15	Locking handle BM10x100
122	G05122	GB4141.14	Locking handle sleeve BM10x50
123	G05123	New Mill Head Crank	Mill Head Crank - Replaced Daigram # 119-122
	G05118	New Replacement	Replaced Daigram # 119-122

# Compound Angle ToolPost

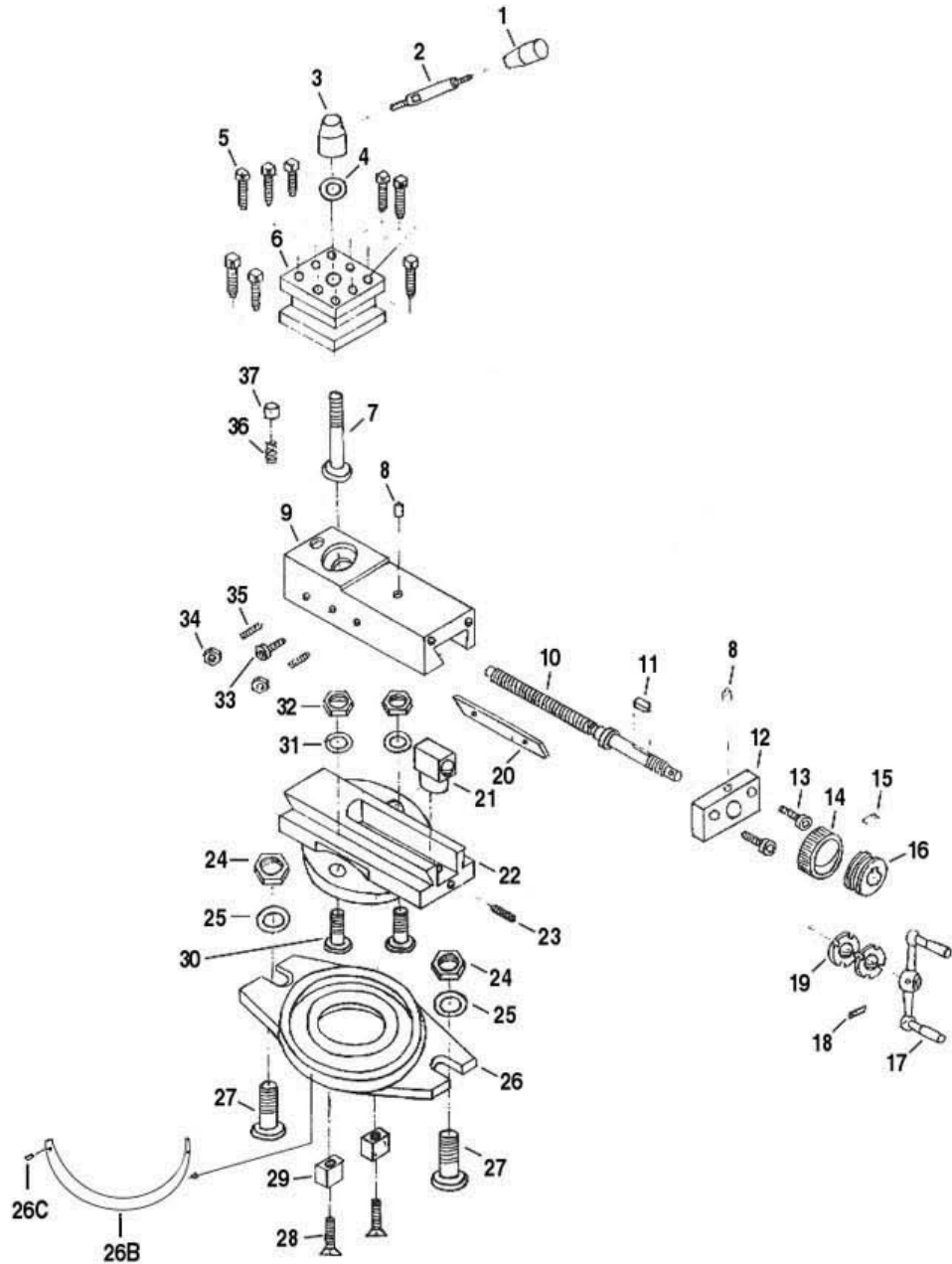

Diagram Number	Part Number	Reference Number	Description
1	G06001	C30054	Handle sleeve BM8x40
2	G06002	C30053	Handle BM8x50
3	G06003	C30185	Handle seat BM12x26
4	G06004	C30556	Washer M10
5	G06005	GB83	Square-head bolt M8x32
6	G06006	C30184	Tool post
7	G06007	S12696	Bolt
8	G06008	C30050	Oiler
9	G06009	C30175	Upper slide
10	G06010	4-06	Screw
11	G06011	GB1096	Key 3x10
12	G06012	4-07	Mount piece
13	G06013	S11671	Sockethead cap screw M5x16
14	G06014	4-08	Dial
15	G06015	C30173	Spring piece
16	G06016	4-12	Dial seat
17	G06017	GB4141.10	Crank handle 8x25

# Compound Angle Toolpost

Diagram Number	Part Number	Reference Number	Description
18	G06018	S22110	Taper pin 3x16
19	G06019	C30220	Spanner nut M10x1
20	G06020	C30176	Gib
21	G06021	C30612	Nut
22	G06022	C30184	Lower slide
23	G06023	GB71	Setscrew M5x10
24	G06024	GB6170 (S18155)	Hex nut M10
25	G06025	GB97.1 (S18170)	Washer
26	G06026	4-14	Mount plate
26B	C30407	C30407	Label
26C	S22355	S22355	Rivet 2.5
27	G06027	GB37	T-bolt M10x30 (S12626)
28	G06028	GB819	Countersunk Phillips screw M4x12
29	G06029	4-10	Locating piece
30	G06030	S12296	T-bolt M8x20 (5/16"x18"x3/4" Carriage Bolt)
31	G06031	S18140	Washer

Diagram Number	Part Number	Reference Number	Description
32	G06032	S18125	Hex nut M8
33	G06033	GB77	Sockethead capscrew M5x15
34	G06034	S18065	Hex nut M5
35	G06035	S11672	Conepoint setscrew M5x16
36	G06036	C30183	Ball with spring
37	G06037	4-17	Stopper
	G06039		Wrench, CATP GN

**Smithy** Granite 1300 Series Operator's Manual  
**Tailstock**

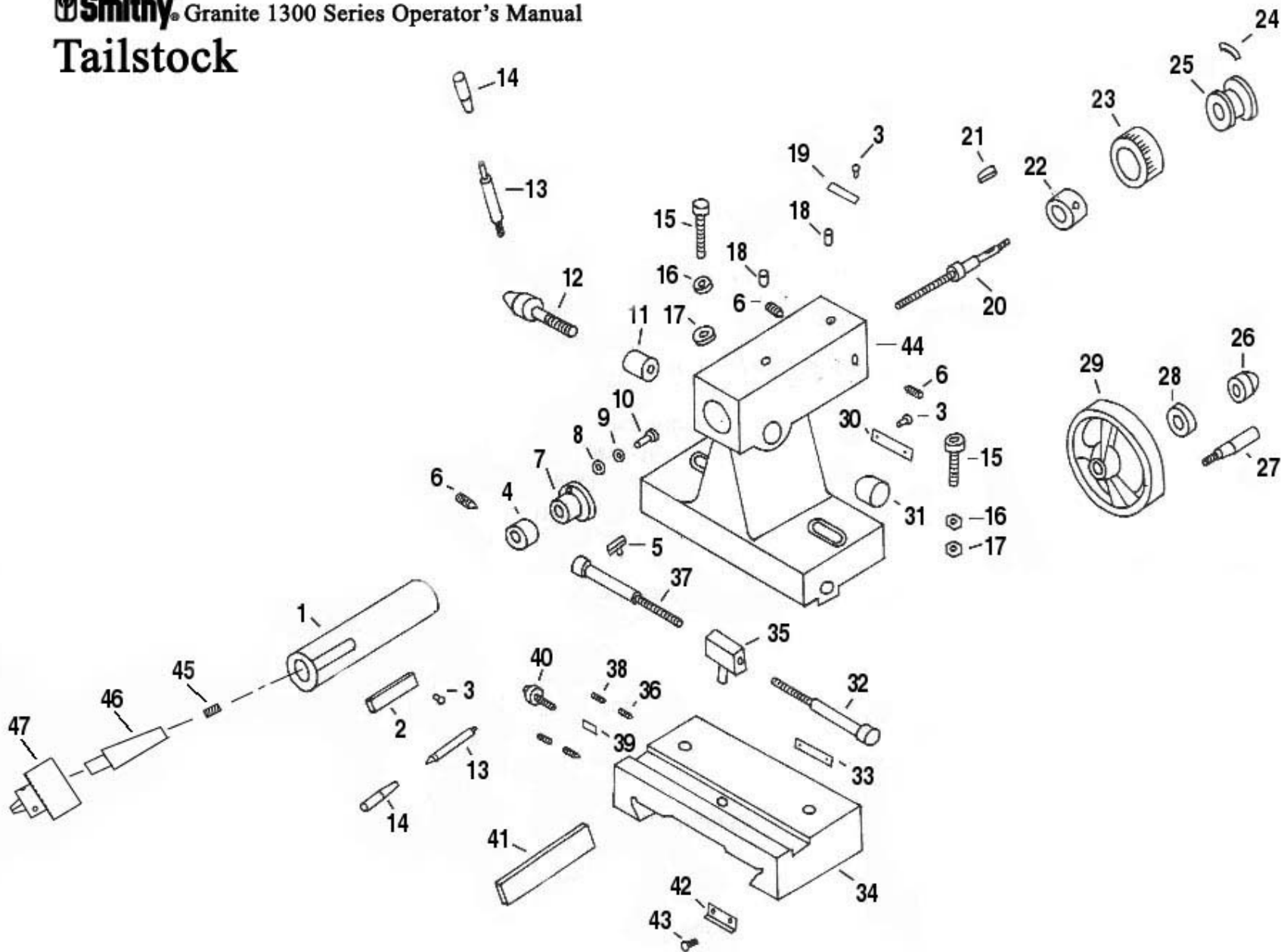



# Tailstock

Diagram Number	Part Number	Reference Number	Description
1	G07001	5-04	Barrel
2	G07002	5-03	Ruler
3	G07003	GB827	Rivet
4	G07004	5-06	Nut
5	G07005	CQ9107.508	T-key
6	G07006	S11632	Setscrew M5x8
7	G07007	5-07	Adjusting nut
8	G07008	GB848	Washer M4
9	G07009	S18045	Lock washer M4
10	G07010	GB818	Setscrew M4x12
11	G07011	5-11	Locking piece (I)
12	G07012	5-10	Locking shaft
13	G07013	GB4141.15	Handle BM8x50
14	G07014	GB4141.14	Handle sleeve BM8x40
15	G07015	GB5783	Hex bolt M10x40
16	G07016	GB93	Lock washer M10
17	G07017	S18170	Washer M10
18	G07018	GB1155	Oiler 5mm (C30050)

Diagram Number	Part Number	Reference Number	Description
19	G07019	ZQ4124-63	Indicator
20	G07020	5-05	Screw
21	G07021	S21170	Key 4x20
22	G07022	5-08	Bushing
23	G07023	5-18	Dial
24	G07024	CQ9109.618	Spring piece
25	G07025	5-09	Dial seat
26	G07026	S18160	Acorn nut M10
27	G07027	GB4141.5	Handle M6x50 (Use G05074)
28	G07028	GB6172	Jam nut M10
29	G07029	GB4141.22	Handwheel B12x100
30	G07030	5-17	Indicator
31	G07031	5-12	Locking piece (II)
32	G07032	GB70	Hex-socket bolt M10x80
33	G07033	5-16	Scale piece
34	G07034	5-01	Tailstock carriage

Diagram Number	Part Number	Reference Number	Description
35	G07035	5-15	Nut
36	G07036	S12278	Half dogpoint setscrew
37	G07037	GB70	Sockethead capscrew M10x40
38	G07038	GB75	Conepoint setscrew M8x12
39	G07039	S22420	Locking pin
40	G07040	5-14	Locking seat
41	G07041	5-13	Gib
42	G07042	6-20	Wiper
43	G07043	GB818	Slotted panhead screw M5x12
44	G07044	5-02	Tailstock
45	S12898		Arbor Plug
46	C30523		Drill Chuck Arbor (No tang)
47	72-001		Drill Chuck JT33

# Carriage Table

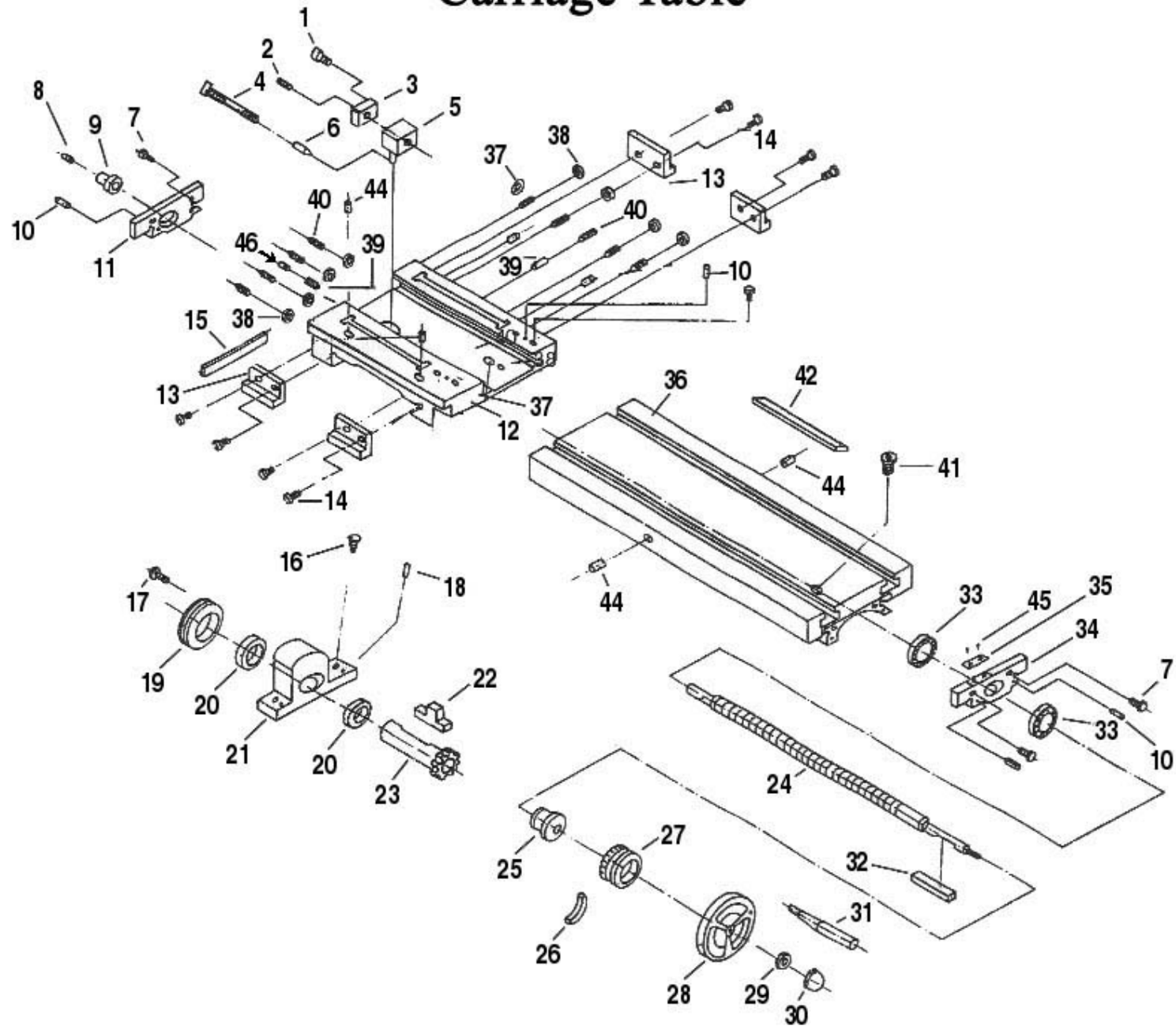

# Carriage Table

Diagram Number	Part Number	Reference Number	Description
1	G08001	S11691	Sockethead capscrew M5x20
2	G08002	S11642	Conepoint slotted setscrew M5x12
3	G08003	6-06	Adjusting nut
4	G08004	GB73	Sockethead capscrew M6x30
5	G08005	6-07	Nut
6	G08006	6-79	Locking pin
7	G08007	S11340	Sockethead capscrew M6x20
8	G08008	GB1155	Oiler
9	G08009	6-01	Bushing (I)
10	G08010	GB117	Taper pin 4x26
11	G08011	6-02	Screw bracket (I)
12	G08012	6-08	Carriage
13	G08013	6-20	Wiper
14	G08014	GB818	Panhead Phillips screw M5x12
15	G08015	6-05	Gib
16	G08016	S11971	Sockethead capscrew M6x16
17	G08017	GB819	Setscrew M4x8
18	G08018	GB117	Taper Pin A4x16

Diagram Number	Part Number	Reference Number	Description
19	G08019	JB24	Locking nut M24x1.5
20	G08020	6-12	Bushing
21	G08021	6-09	Bushing seat
22	G08022	6-10	Key
23	G08023	6-11	Gear sleeve
24	G08024	6-04	Crossfeed screw
25	G08025	6-18	Dial seat
26	G08026	3-19	Spring piece
27	G08027	6-17	Dial
28	G08028	GB4141.22	Handwheel B12x25
29	G08029	GB6172	Jam nut M10
30	G08030	S18160	Acorn nut M10
31	G08031	GB4141.5	Handle M10x80
32	G08032	GB1096	Key 4x28
33	G08033	GB292	Ball bearing 46101
34	G08034	6-16	Screw seat



# Carriage Table

Diagram Number	Part Number	Reference Number	Description
35	G08035	ZQ4124-63	Indicator
36	G08036	6-03	Table
37	G08037	GB79	Sockethead capscrew M10x25
38	G08038	S18125	Hex nut M8
39	G08039	CQ9107.515	Locking pin
40	G08040	Use S11805 / GB79	Dogpoint setscrew M8x45 (M8x50)
41	G08041	GB70	Sockethead capscrew M8x12
42	G08042	6-19	Gib
43	G08043	GB79	Hex-socket setscrews
44	G08044	C30035	Oiler 8 mm
45	G08045	GB827	Rivet 2x5
46	S12618		Locking Bolt M10x25 1.5 Pitch

# Apron

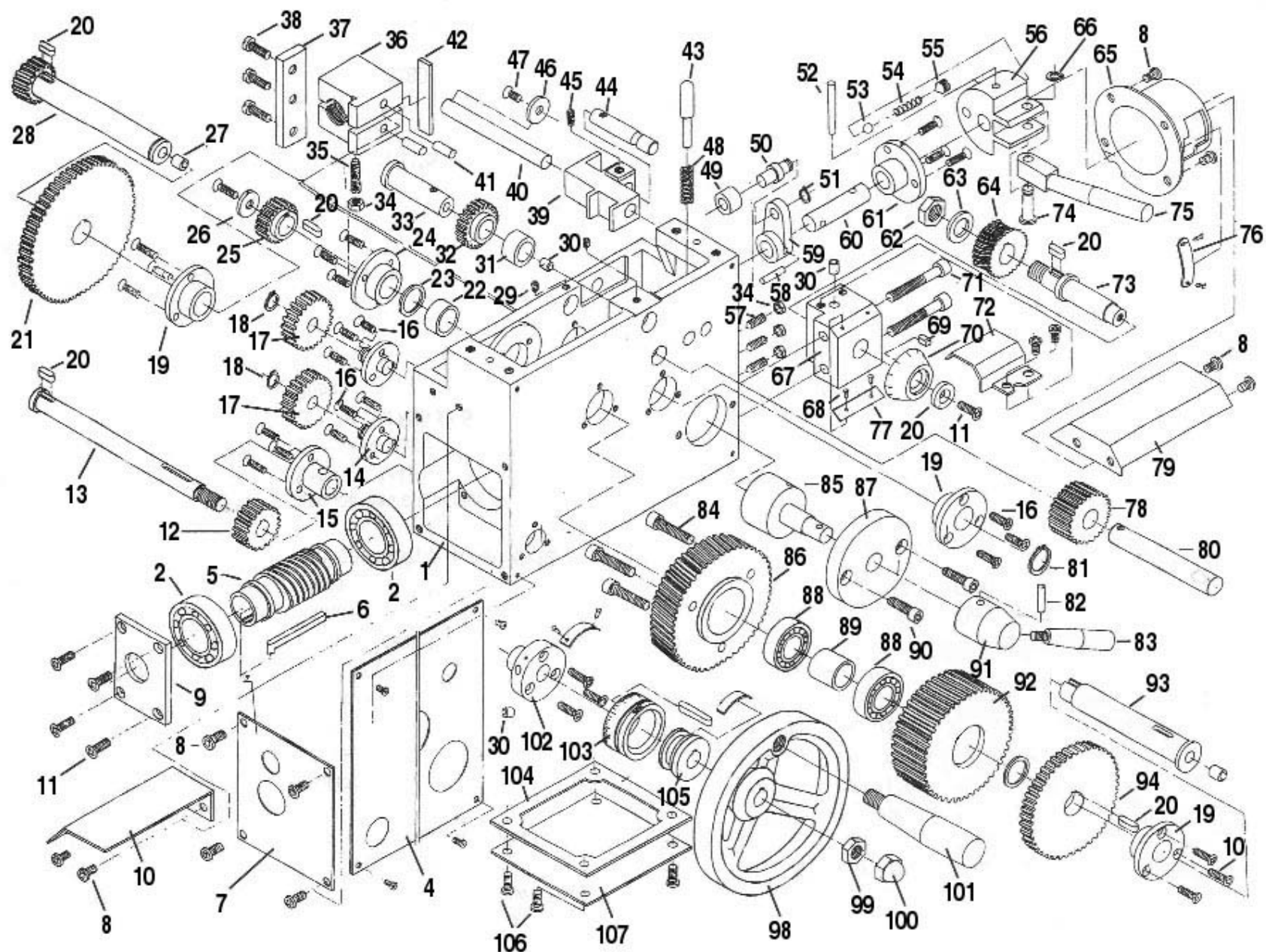

Or Visit [www.Smithy.com](http://www.Smithy.com)

# Apron

Diagram Number	Part Number	Reference Number	Description
1	G09001	6-38	Apron
2	G09002	GB292	Ball bearing 46105
3	G09003	GB818	Setscrew M3x10
4	G09004	6-71	Plate
5	G09005	6-33	Worm
6	G09006	6-47	L-key
7	G09007	6-75	Slide cover
8	G09008	GB818	Panhead Phillips screw M5x8
9	G09009	6-34	Bearing cover
10	G09010	6-35	Leadscrew cover(I)
11	G09011	GB819	Countersunk Phillips screw M5x16
12	G09012	6-41	Gear t20
13	G09013	6-39	Shaft (II)
14	G09014	6-61	Shaft cover
15	G09015	6-40	Bushing(IV)
16	G09016	GB819	Flatpoint setscrew M4x16
17	G09017	6-62	Gear t24

Diagram Number	Part Number	Reference Number	Description
18	G09018	GB894	Snap ring
19	G09019	6-60	Gear shaft cover (V)
20	G09020	GB1096 (S21522)	Key 4x12
21	G09021	6-58	Gear t65
22	G09022	6-56	Spacer
23	G09023	6-53	Washer
24	G09024	6-55	Shaft cover (IV)
25	G09025	6-54	Gear with keyway
26	G09026	6-53	Washer
27	G09027	Use C30035	Oiler 8mmx50190
28	G09028	6-59	Gear shaft
29	G09029	GB71 (S11946)	Conepoint setscrew M4x6
30	G09030	GB1155	Oiler
31	G09031	6-14	Bushing (II)
32	G09032	6-13	Gear t20
33	G09033	6-15	Shaft (I)
34	G09034	GB6172	Hex nut M5



# Apron

Diagram Number	Part Number	Reference Number	Description
35	G09035	GB75	Conepoint setscrew M5x25
36	G09036	6-42	Half nut
37	G09037	6-43	Mount piece
38	G09038	GB65	Panhead Phillips screw M5x16
39	G09039	6-22	Fork
40	G09040	6-21	Stud
41	G09041	GB119	Taper pin B6x16
42	G09042	6-63	Stopping plate (Gib)
43	G09043	6-46	Locking pin (I)
44	G09044	6-48	Locking stud (II)
45	G09045	GB71	Conepoint slotted setscrew M5x12
46	G09046	6-70 (S11512)	Washer M5
47	G09047	GB819	Panhead Phillips screw M5x10
48	G09048	6-47	Spring
49	G09049	6-23	Bushing (III)
50	G09050	6-24	Fulcrum (I)
51	G09051	GB894	Snap ring
52	G09052	GB117	Taper pin 4x40

Diagram Number	Part Number	Reference Number	Description
53	G09053	GB308	Ball 6.5
54	G09054	GB2089	Spring 0.8x5x25
55	G09055	GB71	Conepoint slotted setscrew M8x10
56	G09056	6-26	Power feed handle seat
57	G09057	GB71	Setscrew M5x16
58	G09058	GB117	Taper pin A4x20
59	G09059	6-29	Crank arm
60	G09060	6-27	Arm shaft
61	G09061	6-28	Shaft pin seat
62	G09062	GB6172	Hex nut M12
63	G09063	6-65	Washer M12
64	G09064	6-66	Worm gear
65	G09065	6-25	Positioning cover
66	G09066	GB894	snap ring
67	G09067	6-67	Threading dial seat
68	G09068	GB827	Rivet 2x5



# Apron

Diagram Number	Part Number	Reference Number	Description
69	G09069	GB1096	Key 4x8
70	G09070	6-69	Threading dial
71	G09071	(S12051)GB70	Sockethead capscrew M6x45
72	G09072	6-64	Worm cover
73	G09073	6-68	Threading dial shaft
74	G09074	6-31	Clevis pin
75	G09075	6-30	Handle
76	G09076	6-49	Feeding direction plate
77	G09077	ZQ4124-63	Indicator
78	G09078	6-50	Gear t23
79	G09079	6-78	Leadscrew cover (II)
80	G09080	6-51	Shaft (III)
81	G09081	GB894	Snap ring
82	G09082	GB117	Taper pin A4x26
83	G09083	GB4141.1	Handle M6x50
84	G09084	GB70	Sockethead capscrew M6x30
85	G09085	6-44	Half-nut closer
86	G09086	6-32	Helical gear t60

Diagram Number	Part Number	Reference Number	Description
87	G09087	6-45	Half-nut closer seat
88	G09088	GB276	Ball bearing
89	G09089	6-73	Bushing (V)
90	G09090	GB70	Sockethead capscrew M5x20
91	G09091	CJ0625.3-21	Handle seat
92	G09092	6-74	Gear t52
93	G09093	6-57	Shaft (IV)
94	G09094	6-72	Gear with keyway
95	G09095	GB819	Setscrew M4x20
96	G09096	GB1096	Key4x28
97	G09097	CJ0625.3-19	Spring piece
98	G09098	GB4141.22	Handwheel B12x125
99	G09099	S18155	Hex nut M10
100	G09100	S18160	Acorn nut M10
101	G09101	GB4141.5	Handle M10x80
102	G09102	6-37	Shaft cover (II)

# Apron

Diagram Number	Part Number	Reference Number	Description
103	G09103	6-36	Dial
104	G09104	6-76	Gasket
105	G09105	6-18	Dial seat
106	G09106	GB818	Panhead Phillips screw M5x12
107	G09107	6-77	Bottom cover
	G99-000		Entire Apron Assembly

# Gearbox

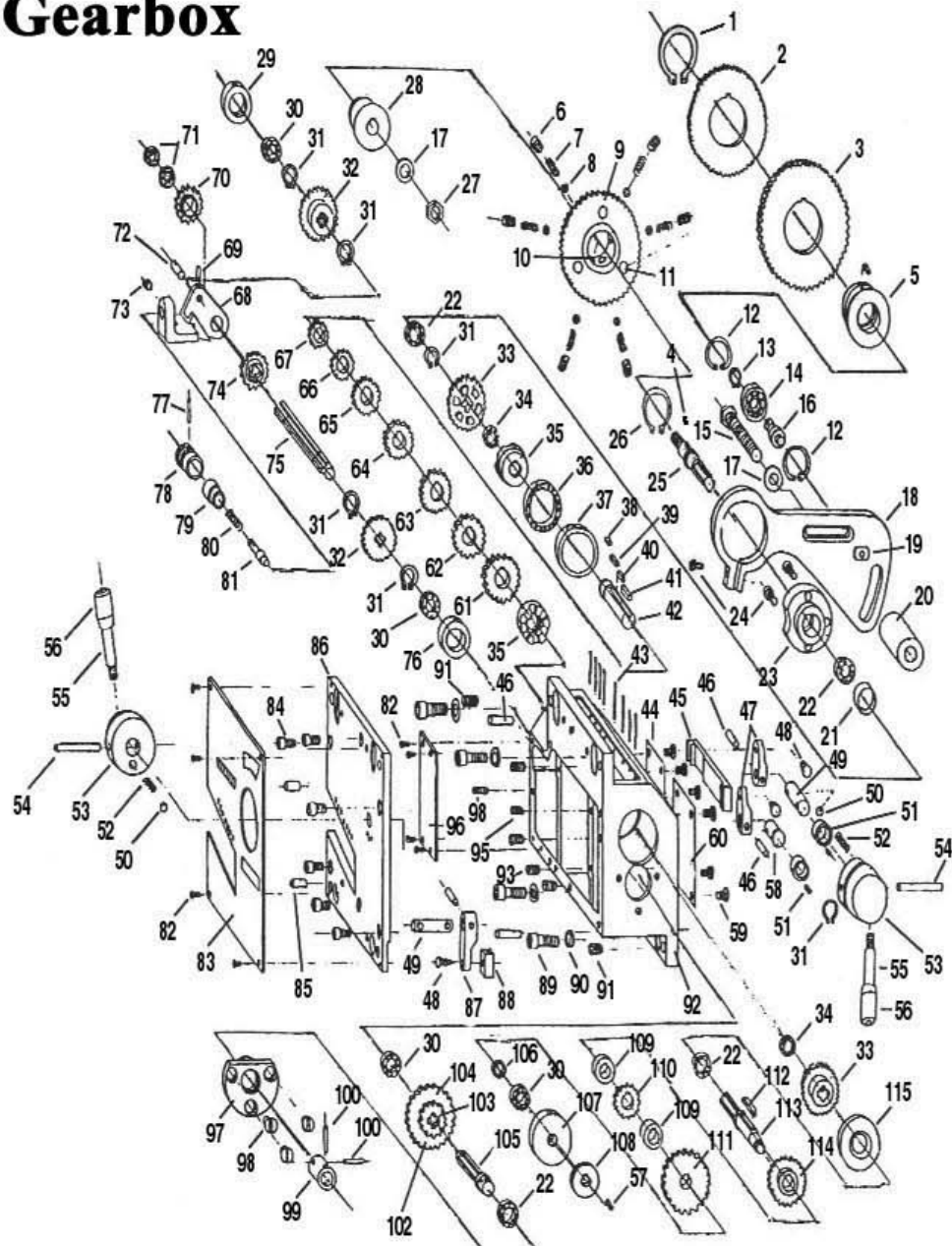

Diagram Number	Part Number	Reference Number	Description
1	G10001	GB894.1	Snap ring ( <b>S23038</b> )
2	G10002	7-27	Outside gear with key
3	G10003	7-27	Inside gear with key
4	G10004	GB1096	Key 4x16
5	G10005	7-26	Bushing
6	G10006	GB73	Flatpoint setscrew M8x8
7	G10007	CQ9109.7-35	Spring
8	G10008	GB308	Ball
9	G10009	7-28	Gear
10	G10010	7-29	Outer sleeve
11	G10011	GB869	Rivet 4x22
12	G10012	GB893.1	Snap ring
13	G10013	GB894.1	Snap ring
14	G10014	GB276	Ball bearing
15	G10015	GB5780	Hex bolt M10x90
16	G10016	7-24	Shaft
17	G10017	GB95	Washer M10

# Gearbox

Diagram Number	Part Number	Reference Number	Description
18	G10018	7-23	Bracket
19	G10019	7-25	T-nut
20	G10020	7-22	Spacer
21	G10021	7-31	Spacer
22	G10022	GB276	Ball bearing 1000801
23	G10023	7-21	Bearing seat
24	G10024	GB70 (S12516)	Sockethead capscrew M5x16
25	G10025	7-20	Shaft #1
26	G10026	GB894.1	Snap ring
27	G10027	S18155	Hex nut M10
28	G10028	7-30	Inner sleeve
29	G10029	7-32	Bearing seat
30	G10030	GB276	Ball bearing 1000099
31	G10031	GB894.1	Snap ring
32	G10032	7-37	Spline gear
33	G10033	7-16	Spline clutch gear
34	G10034	GB276	Ball bearing 1000069

Diagram Number	Part Number	Reference Number	Description
35	G10035	7-17	Clutch jaw
36	G10036	GB276	Ball bearing 1000806
37	G10037	7-39	Bearing seat
38	G10038	GB1096	Key 4x6
39	G10039	GB1096	Key 4x22
40	G10040	GB1096	Key 4x18
41	G10041	GB1096	Key 4x22
42	G10042	7-19	Shaft with keyway
43	G10043		Oil felt 2x50
44	G10044	7-49	Cover (I)
45	G10045	7-45	Fork
46	G10046	GB117	Pin 5x26
47	G10047	7-43	Crank arm
48	G10048	7-44	Connecting pin
49	G10049	7-46	Handle shaft
50	G10050	GB308	Ball 6.5
51	G10051	7-42	Spacer



# Gearbox

Diagram Number	Part Number	Reference Number	Description
52	G10052	GB2089	Spring 0.5x5x25
53	G10053	GB4141.19	Handle seat 12x50
54	G10054	GB117	Taper pin A5x50
55	G10055	GB03067	Handle BM8x50
56	G10056	GB03063	Handle sleeve BM8x40
57	G10057	GB73	Conepoint setscrew M4x8
58	G10058	7-41	Shaft
59	G10059	GB6	Setscrew M5x8
60	G10060	7-50	Cover (II)
61	G10061	7-18	Gear #7
62	G10062	CQ9109.706	Spline gear #6
63	G10063	CQ9109.706	Spline gear #5
64	G10064	CQ9109.706	Spline gear #4
65	G10065	CQ9109.706	Spline gear #3
66	G10066	CQ9109.706	Spline gear #2
67	G10067	CQ9109.706	Spline gear #1
68	G10068	7-38	Tumbler
69	G10069	GB71	Conepoint setscrew M4x8

Diagram Number	Part Number	Reference Number	Description
70	G10070	CQ9109.736	Idle gear
71	G10071	GB276	Ball bearing 1000096
72	G10072	GB119	Pin B6x24
73	G10073	GB71	Conepoint slotted setscrew M6x8
74	G10074	CQ9107.738	Sliding gear
75	G10075	7-36	Shaft #2
76	G10076	7-40	Bearing seat
77	G10077	GB117	Taper pin A2x18
78	G10078	CQ9109.719	Gripper
79	G10079	CQ9109.718	Gripper sleeve
80	G10080	CQ9109.717	Spring
81	G10081	7-51	Positioning pin
82	G10082	GB818	Panhead Phillips M3x8
83	G10083	7-35	Gearbox plate
84	G10084	GB70	Hex socket screw M6x12
85	G10085	GB118	Inner thread taper pin A6x16

# Gearbox

Diagram Number	Part Number	Reference Number	Description
86	G10086	7-34	Gearbox cover
87	G10087	7-47	Crank arm
88	G10088	CQ9109.751	Fork
89	G10089	GB70	Hex socket screw
90	G10090	GB95	Washer
91	G10091	GB73	Flatpoint slotted
92	G10092	7-01	Gearbox
93	G10093	GB71	Flatpoint slotted setscrew M6x12
94	G10094	GB71	Flatpoint slotted setscrew M6x16
95	G10095	GB71	Setscrew M5x12
96	G10096	7-33	Left cover
97	G10097	7-03	Bearing seat
98	G10098	GB68	Panhead Phillips M6x12
99	G10099	CQ9109.725	Sleeve
100	G10100	GB117	Taper pin 3x20
101	G10101	GB73	Pin M4x12
102	G10102	7-05	Sliding gear(II)

Diagram Number	Part Number	Reference Number	Description
103	G10103	7-04	Sliding gear (I)
104	G10104	7-06	Sliding gear (III)
105	G10105	7-02	Shaft #5
106	G10106	7-09	Spacer
107	G10107	7-10	Bearing seat
108	G10108	7-08	Knob
109	G10109	7-12	Spacer
110	G10110	7-13	Gear (II)
111	G10111	7-11	Gear (I)
112	G10112	GB1096	Key 4x45
113	G10113	7-07	Shaft #4
114	G10114	7-14	Gear (III)
115	G10115	7-15	Bearing seat

# Speed Reduction Pulley 40-300G

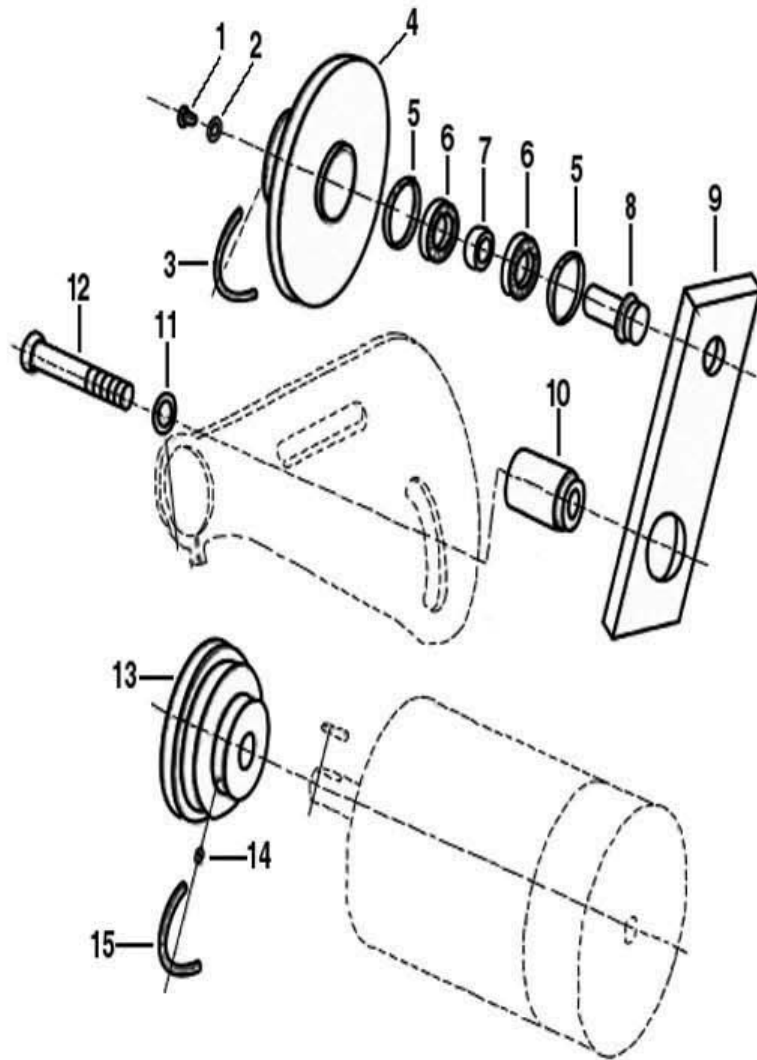

Diagram Number	Part Number	Reference Number	Description
1	S11680	GB818-85	Pan head screw M6-1.0 x 8
2	S18110	G1324F.8-05	Washer M6
3	G02034	GB1171-74	V-Belt A710
4	G02035	G1324F.8.02	Middle pulley
5	LX03280	GB893-86	Internal retaining clip
6	G02036	GB276-82	Single row ball bearing 100090
7	G02037	G1324F.8-04	Spacer ring
8	G02038	G1324.8-03	Support shaft
9	G02039	G1324.8-01	Support plate
10	G02040	G1324.8-07	Support washer for adjustable gear
11	S18170	GB95-85	Washer, M10
12	S12109	GB5780-86	Bolt M10 x 90
13	G02027A	G1324.1-04(a)	Motor Pulley
14	S11942	GB71-85	Screw, set cone point M6 x 10
15	G02043	GB1171-74	V-Belt A630

# Granite 1340 Stand

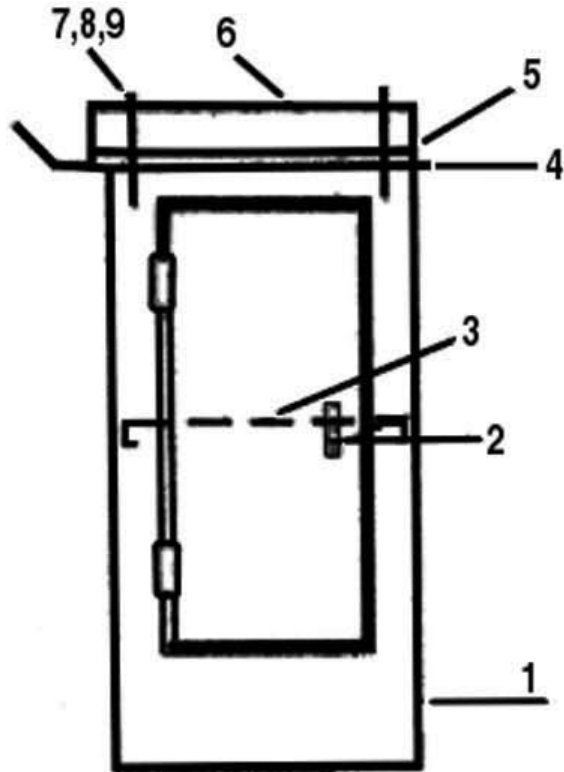

Diagram Number	Part Number	Reference Number	Description
1	80-020	Right/Left	Left/Right base
2			Door lock
3			Shelf
4	G14001		Chip tray
5	G14005		Rubber washer
6	G14004		Left/Right block
7	S12650		Socket Cap Screw M10 x 45 (4 Total)
8	S18170		Nut M10 (4 Total)
9	S18200		Washer M10 (4 Total)
10			Bolt M12 x 90 (4 Total-Use to secure machine to stand)
11	S18200		Washer M12 (8 Total-Use to secure machine to stand)
12	S18185		Nut M 12 (4 Total-Use to secure machine to stand.)
13	S18331		Nut M6 (6 Total-Use for securing connecting plate to left and right base)
14	S11620		Screw, pan head M6 x 20( 6 Total-Use for securing connecting plate to left and right
15	G14002		Connecting Plate (connects right & left ends, not shown)