

Philmac Metric Tapping Saddles.



The Philmac Metric Tapping Saddle is a fitting engineered for use above or below ground for the transfer of fluids; including water, chemicals or slurries, frequently encountered in the utilities, mining or irrigation industries.

Features

- PN16 pressure rating. Complies to draft specification AS 4129, "Fittings for PE Pipes for pressure applications".
- Nitrile sealing gasket for excellent sealing performance and chemical resistance.
- Suitable for contact with potable water – complied with AS3855 and AS40210 (int).
- High grade polypropylene body selected for its tough, high impact, lightweight, and durable properties.
- Stainless steel reinforcing rings on threaded branch.
- Bolt clips to facilitate easy assembly.
- Bolt hole guides to assist bolt insertion.
- Hexagon moulding to prevent bolt turning during assembly.
- Supplied with either Class 316 Stainless Steel or Zinc electroplated steel nuts and bolts.

Philmac[®]

Making water work for you!

S P E C I F I C A T I O N S

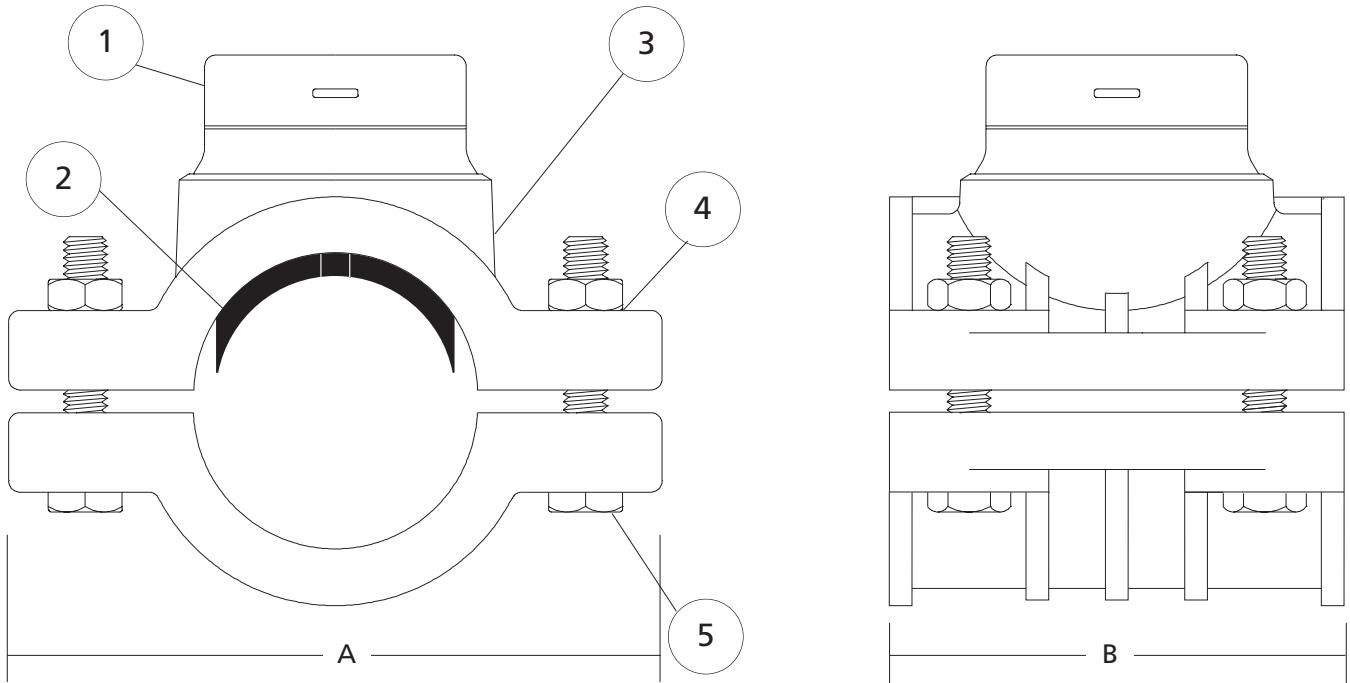

Parts and material

No.	Description	Material	Quantity
1	Reinforcing ring	Stainless steel 304	1
2	Sealing gasket	Nitrile rubber	1
3	Body	Polypropylene	1
4	Nut	Zinc electroplated steel or stainless steel 316	4 (2 for 25 and 32mm)
5	Bolt	Zinc electroplated steel or stainless steel 316	4 (2 for 25 and 32mm)

Dimensions

Saddle size (mm)	Hexagon nuts	Bolt Dimensions (mm)	Dimension A (mm)	Dimension B (mm)
25	M8	M8 x 45	82	54
32	M8	M8 x 45	92	66
40	M8	M8 x 45	96	67
50	M8	M8 x 45	115	80
63	M8	M8 x 55	126	89
75	M10	M10 x 65	141	99
90	M10	M10 x 65	160	104
110	M10	M10 x 65	181	108

O P E R A T I O N

Robust saddle tower design for long term stress

Sealing gasket is compressed onto pipe surface and provides tolerance to scuffed, scratched or oval pipe

Rounded body shape prevents unnecessary stress on body during assembly

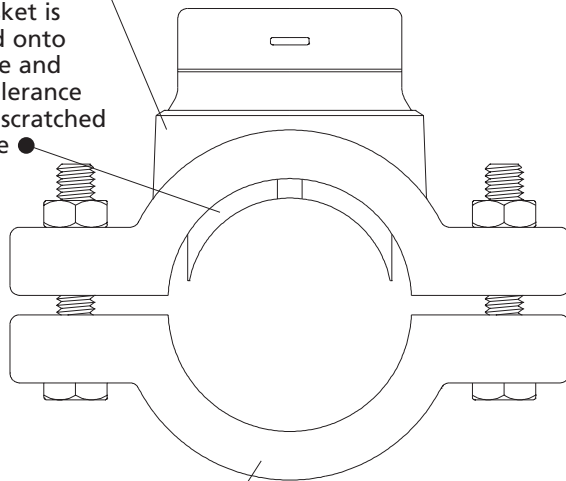

Reinforcing ribs strengthen pressure performance

Stainless steel reinforcement ring provides superior support to female off-take thread

Clips prevent bolt from displacing during assembly

Hexagonal groove prevents bolts from turning when tightening nut

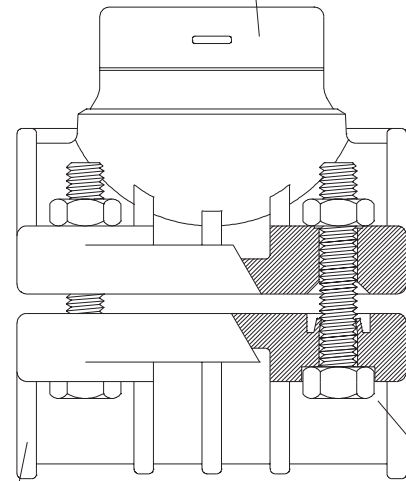

I N S T A L L A T I O N

Use

Can be used to fit a wide range of pipes from PN6.3 to PN16 including MDPE, HDPE, PP or ABS that have metric external diameter dimensions.

Pre Assembly

Select branch off-take position, clean pipe, ensure easy access and mark hole. Place saddle upper body and align outlet branch with marked hole.

Assembly

Place saddle lower body over pipe. Ensure thread of bolts are clean before placing in saddle. Tighten all bolts alternately around saddle. ensure saddle off-take hole stays in alignment with marked hole.

Drill suitable sized hole through orifice of saddle with boring tool. Ensure that the threads and gasket are not damaged.

Disassembly

Loosen and detach all bolts around saddle.

Note:

1. Philmac recommends the use of PTFE tape on BSP threads to ensure a positive seal.
2. Philmac uses 316 high class Stainless Steel nuts and bolts. Inherent in the nature of all Stainless Steel nuts and bolts is that they can fuse following installation. Lubrication of threads before installation may help to prevent this occurring.

R A N G E

Dimensions

Pipe External diameter (mm)	Threaded off take FI BSP)	Part Number Stainless Steel Nuts and Bolts	Part Number Zinc Plated Nuts and Bolts
25	3/4'	97753200	97703200
32	3/4'	97754200	97704200
32	1'	97754300	97704300
40	3/4'	97755200	97705200
40	1'	97755300	97705300
50	3/4'	97756200	97706200
50	1'	97756300	97706300
63	3/4'	97757200	97707200
63	1'	97757300	97707300
63	1 1/2'	97757500	97707500
75	3/4'	97758200	97708200
75	1'	97758300	97708300
75	1 1/2'	97758500	97708500
75	2'	97758600	97708600
90	1'	97759300	97709300
90	1 1/2'	97759500	97709500
90	2'	97759600	97709600
110	1'	97750300	97700300
110	1 1/2'	97750500	97700500
110	2'	97750600	97700600

Philmac manufacture a range of complementary fittings and valves to complete the system.



Quality Endorsed Company

ISO 9002 Lic 2658
Standards Australia

Please note that the information, opinions, recommendations and advice given on this specification sheet are supplied only to provide an improved understanding of the technical aspects of Philmac Tapping Saddles. So far as the law allows, Philmac Pty. Ltd. will not accept liability in respect of any loss or damage of any kind claimed to arise as a result of reliance upon any information contained on this specification sheet. Please refer to our Terms and Conditions of Supply of goods.



Philmac Pty Ltd
53-59 Deeds Road
North Plympton
SA 5037, Australia
Telephone (08) 8300 9200
Facsimile (08) 8300 9390
Web: <http://www.philmac.com.au>